

277

The Structure of Protoplasm

A MONOGRAPH OF
THE AMERICAN SOCIETY OF
PLANT PHYSIOLOGISTS

Marine Biological Laboratory



Received Apr 1, 1968

Accession No. 54064

Given By D. Douglas Fairland
York University

Place, _____

MBL/WHOI



0 0301 001285 9



THE STRUCTURE OF PROTOPLASM



422

A Symposium on
**THE STRUCTURE OF
PROTOPLASM**

A MONOGRAPH OF THE
AMERICAN SOCIETY OF
PLANT PHYSIOLOGISTS

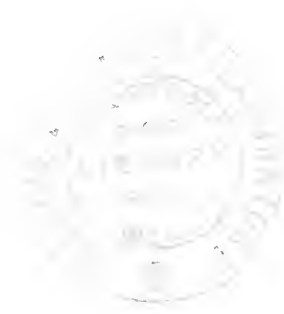

Edited By
WILLIAM SEIFRIZ

PUBLISHED, 1942
THE IOWA STATE



AT AMES, IOWA
COLLEGE PRESS

COPYRIGHT 1942, BY THE
IOWA STATE COLLEGE PRESS

PRINTED AT THE COLLEGIATE PRESS, INC.
IOWA STATE COLLEGE, AMES, IOWA, U.S.A.

FOREWORD

This monograph is the printed record of a symposium on the Structure of Protoplasm presented under the auspices of the American Society of Plant Physiologists at Philadelphia on December 30, 1940.

The meeting was held under the Presidency of Dr. F. P. Cullinan, with Dr. William Seifriz as chairman. The symposium was the partial fulfillment of a plan, long held by the chairman, for a series of lectures on the structure of matter in which physicists and chemists would build structural units to be used by biologists in an attempt to construct a mechanism having some of the properties of a living system. Though no physicists or chemists in the strict sense actually took part in the symposium, yet several were indirectly involved; thus Professor Herbert Freundlich, who was invited to attend but could not come, offered a paper on Thixotropy which proved to be his last manuscript. Another chemist, Dr. Linus Pauling, has made a substantial contribution to the Monograph by aiding in the writing of the Introduction. Throughout the chapters is evidence of assistance from other physicists and chemists, notably Dr. W. T. Astbury, Dr. H. Mark, and Dr. Kurt Meyer, two of whom have made brief, last-minute contributions of their own which have been put in a Supplement.

This volume is the first in what is planned to be a series of monographs to be published under the auspices of the American Society of Plant Physiologists. It is appropriate that the first monograph should deal with so basic a subject as the structure of living matter. It is the wish of the authors that this monograph reawaken among American botanists an interest in a study which occupied so much of the time of European botanists during the past century. It was a botanist, Karl von Naegeli, who gave biology and chemistry one of the first fundamental theories of protoplasmic and gel structure, and it was a botanist, Fr. Weber, who established the first journal devoted solely to a study of protoplasm. By inaugurating its series of monographs in plant physiology, with a volume on the structure of protoplasm, the American Society of Plant Physiologists takes

a forward step in advancing one of the most fundamental subjects in science.

The Society is deeply indebted to all who contributed to the success of the symposium and of this volume. Especial appreciation is due Dr. William Seifríz for the knowledge, skill, and enthusiasm which have made the project possible.

W. E. LOOMIS
Secretary-treasurer
American Society of Plant Physiologists

AMES, IOWA
JUNE 1, 1941

TABLE OF CONTENTS

FOREWORD	<i>W. E. Loomis, Iowa State College</i>	v
INTRODUCTION	<i>William Seifriz, University of Pennsylvania</i>	1
MICROSCOPIC STRUCTURE OF THE CELL WALL	<i>Charles W. Hock, Textile Research Foundation, Bureau of Standards</i>	11
PROTEINS AND PROTOPLASMIC STRUCTURE	<i>Laurence S. Moyer, University of Minnesota</i>	23
MOLECULAR STRUCTURE IN PROTOPLASM	<i>O. L. Sponsler and Jean D. Bath, University of California</i>	41
SOME MECHANICAL PROPERTIES OF SOLS AND GELS AND THEIR RELATION TO PROTOPLASMIC STRUCTURE	<i>Herbert Freundlich, University of Minnesota</i>	85
STRUCTURAL DIFFERENTIATION OF CYTOPLASM	<i>G. W. Scarth, McGill University</i>	99
STRUCTURAL DIFFERENTIATION OF THE NUCLEUS	<i>C. L. Huskins, McGill University</i>	109
PROTOPLASMIC STREAMING IN RELATION TO GEL STRUCTURE IN THE CYTOPLASM	<i>Douglas A. Marsland, New York University</i>	127
THE RELATION OF THE VISCOSITY CHANGES OF PROTOPLASM TO AMEBOID LOCOMOTION AND CELL DIVISION	<i>Warren H. Lewis, Wistar Institute</i>	163
PHYSICAL ASPECTS OF PROTOPLASMIC STREAMING	<i>Noburô Kamiya, University of Tokio</i>	199
SOME PHYSICAL PROPERTIES OF PROTOPLASM AND THEIR BEARING ON STRUCTURE	<i>William Seifriz, University of Pennsylvania</i>	245
SUPPLEMENT:		
PROTEIN AND PROTOPLASMIC STRUCTURE, <i>Communication from Kurt H. Meyer, University of Geneva</i>		267
Letter From <i>W. T. Astbury, University of Leeds</i>		270
INDEX		273

54964

INTRODUCTION

WILLIAM SEIFRIZ

The contributors to this symposium on protoplasm will deal with present-day concepts on the structure of living matter. A brief recounting of past theories will, therefore, serve as an introduction. In addition, there is the matter of the future. But first I should like to consider for a moment why it is of structure that we speak.

A symposium on protoplasm in which structure is the chief theme suggests that structure is the most significant property of living matter. This is true. One may even go so far as to say that it is a specific structure of matter which distinguishes the living from the nonliving.¹

The chemical composition of protoplasm is important to life. Water is the dispersion medium. Salts are required to maintain physical qualities. Sugars are needed for respiratory oxidations. Fats serve as reserve energy. And proteins are the material out of which the structural framework of living matter is made. The composition is important, but it is secondary to arrangement, to organization, to structure. The proteins, for example, hold a pre-eminent position among the constituents of protoplasm because they are structural material.

One may agree to the secondary position of composition and yet regard emphasis on structure as arbitrary in view of the fact that protoplasm is, above all, a dynamic system and not a static one. An outstanding quality of living matter is activity, and activity is a manifestation of energy. Energy, composition, and function are as essential to a mechanism as is structure, and energy is particularly significant in a living system. Indeed, one of the primary attributes of life is the capacity of living matter to use energy in the synthesis of protoplasm, whereas the synthesis of nonliving organic substances involves the liberation of energy.

The primary source of energy in protoplasm appears to be the oxidation of carbohydrates, but this is not in itself an extraordinary reaction. It is not the kind of energy but the use to which this energy is put which distinguishes protoplasm; and this uniqueness of living

¹ *Philos. of Sci.*, 6:266, 1939.

matter is very probably due to a specific arrangement of parts, that is to say, to structure.

Often I am asked by physicists and chemists if much can be hoped for in the way of an understanding of protoplasmic structure. Direct observation, even with the highest powers of the microscope, is too superficial to reveal anything fundamental. Chemical analysis is not productive of significant results because once protoplasm is subjected to severe treatment it is no longer living matter. The very structural features which distinguish it from the nonliving are then destroyed.

The biologist interprets the basic structure of protoplasm somewhat in the same way that a chemist interprets the structure of a compound, namely, by its behavior. The chemist sees nothing of the links, rings, side chains, amino and carboxyl groups which he attaches here and there, yet he builds up a structure with considerable confidence, which is the justification of stereochemistry. Just so does the biologist work; he interprets the structure of living matter in the light of its known physical properties. But this was not the method of the older biologists, and herein lay their error. They told only of what they saw.

Protoplasm viewed through the microscope appears to be a suspension of fine granules. On this fact was based the granular hypothesis of protoplasmic structure. Its weakness lay in the diversity of the granules and the undue significance given them. Some are admittedly important, as are the plastids and the mitochondria; others, such as fat droplets, are but reserve food. These last are really not granules at all but liquid droplets which make of cytoplasm a fine emulsion. The importance attributed to the "granules"—they were regarded by some as living units, morphologically and physiologically independent of the cell—and the necessary coarseness of any optically visible structure, led to the discarding of the granular hypothesis.

The belief that the basic structural unit of protoplasm is a spherical body has long persisted and has given rise to numerous hypotheses expressed in terms of granules, globules, alveoli, and micellae. Such suggestions are in part supported by fact. Thus, protoplasm is unquestionably an emulsion, and when the emulsion globules are under pressure and symmetrically arranged they assume the shape of dodeca- or tetrakaidecahedra which are hexagonal in cross section. These latter are alveoli.²

² *Protoplasma* 9:177, 1930.

Emulsion hypotheses of protoplasmic structure were favorably entertained by biologists, but an emulsion satisfies very few of the requirements of a living system, and fails utterly as a mechanical basis of most physical properties of protoplasm and elastic gels. Emulsions do not take up water by imbibition, whereas protoplasm does. Emulsions do not coagulate. Emulsions are not elastic as is protoplasm. A mathematical analysis led Hatschek³ to the conclusion that an emulsion structure of elastic gels is untenable.

Biologists were misled by the presence in natural emulsions of a stabilizer, a third substance, in addition to the water and oil of the emulsion proper. It is this third substance, often a protein, which exhibits the physical characteristics of protoplasm, and of jellies in general, characteristics wrongly ascribed to a pure emulsion. Milk illustrates the situation well. Superficially, milk is an emulsion of butterfat dispersed in water, but when milk coagulates, the emulsion plays no active part whatever. It is the stabilizing substance, a protein, in milk which coagulates. And so it is with protoplasm.

The introduction of the cytological technique of fixing and staining gave rise to numerous theories of protoplasmic structure based on what was seen in prepared tissues. Much controversy developed over the reality of these structures in living protoplasm, because fixation produces artifacts.

The fibrillar and reticular theories are the best known among those based on classical cytological methods. Fibrillar and reticular structures in prepared sections of tissues may well be artifacts, but an artifact is not without significance. The relatively coarse microscopic threads which form the visible fibrous entanglement or net, may be artificially produced aggregates of threads of submicroscopic dimensions. These latter are probably linear molecules. It seems rather unlikely that a coarse fibrous coagulum should result from the fixation of a fine granular suspension. Thus do the visible threads of a reticulum in fixed dead material become evidence of submicroscopic threads in living protoplasm.

The first hypothesis of protoplasmic and gel structure which held the serious attention of chemists as well as biologists was the contribution of the botanist Karl von Naegeli. He postulated molecular aggregates of colloidal size. These aggregates Naegeli called micellae. They might have a random distribution, or as later thought more probable, a symmetrical arrangement, like bricks in a wall (Fig. 1).

³ Trans. Faraday Soc. 12:17, 1917.

This was, and still is by some, assumed to be the structure of cellulose. The concept had one great fault, there was nothing to account for a strong bond between micellae (at c and d, Fig. 1). A cementing

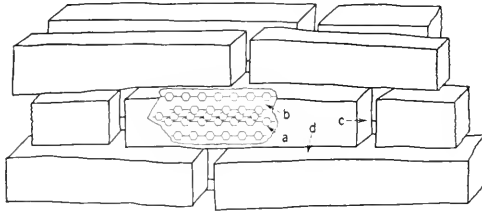

FIG. 1

material was assumed, but to attribute the tensile strength of cellulose to an intermicellar substance, rather than to the micellae themselves, was poor reasoning. Again the fallacy lay in attempting to build an elastic substance of high tensile strength out of granules. Protoplasm hangs together, and so does cloth; the latter we know to be made of threads. In order to satisfy the elastic and tensile qualities of jellies, the "brush-heap" theory of interlacing fibers was formulated.⁴

The brush-heap theory had several advantages; an entanglement of fibers is elastic (Fig. 2). A brush-heap was acceptable to both the proponents of a molecular structure of elastic gels (A, Fig. 2), and to those who supported a colloidal or micellar brush-heap (B, Fig. 2). But the hypothesis failed as an explanation of certain optical prop-

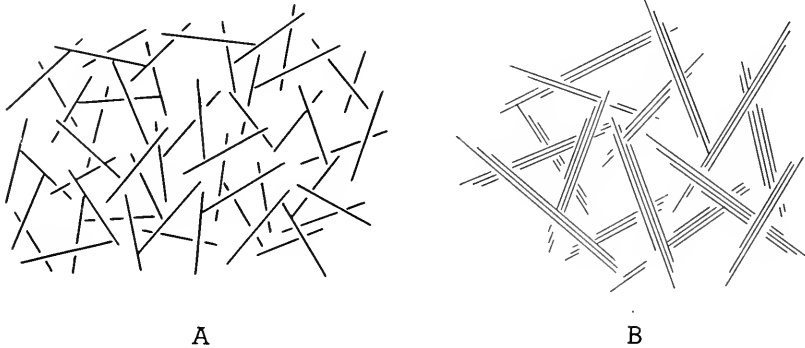

FIG. 2

erties, such as double refraction, and crystalline symmetry as indicated by X-ray patterns.

Out of the micellar and brush-heap hypotheses there arose the concept of symmetrically arranged overlapping fibers (Fig. 3).

⁴Protoplasm, New York, 1936.

High tensile strength was particularly well explained by this arrangement. But there was still reason to believe that some discontinuity is present in cellulose and like material.

An examination of natural cellulose with dark-field illumination



FIG. 3

reveals the presence of short rods, 1.5 to 2μ in length, regularly spaced in parallel rows (Fig. 4).

Preston⁵ compares the actual and theoretical tensile strengths of cellulose and finds that the former is 20 kg/mm² for cotton and 100 kg/mm² for flax, whereas the theoretical tensile strength for cellulose, based on the known chemical energy of the C-C link, is 900 kg/mm². Discontinuity in the structural arrangement of parts would account for the lowered tensile strength. The micellar hypothesis appears, therefore, to still hold.

The demands made by elasticity indicate that jellies are built of fibers. Low tensile strength, as in cellophane, suggests a scattered distribution (Fig. 2). High tensile strength, as in ramie fiber, requires overlapping (Fig. 3). And certain optical properties indicate discontinuity (Fig. 4).

The best interpretation, so it seems to me, of these somewhat contradictory requirements is that indicated in Figure 5 where symmetrically arranged overlapping fibers are concentrated at regular intervals

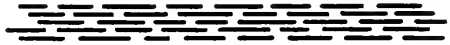

FIG. 4

(See also Fig. 1, page 268).

Out of the numerous facts and suggestions so far mentioned, the most significant is the recognition that the structural unit of elastic jellies is a fiber. This is a great gain over older concepts in which granules and globules were the structural units of protoplasm.

The foregoing is the background of our subject. The present will be dealt with by the contributors to this Monograph. There remains the future.

The final word on the full meaning of protoplasmic structure will rest with the biologist, for he alone knows the conditions to be met,

⁵ Biol. Revs., 14:281, 1939.

physical, cytological, and genetical. But the manner in which water, salts, carbohydrates, fats, and proteins combine so as to fulfill the biological requirements of a living system, only the chemist and physicist can say. The direction which this cooperation between physicist, chemist, and biologist is likely to take—in short, what the future has in store for us in the matter of protoplasmic structure—may be illustrated by a problem, a very fundamental one, namely, the maintenance in protoplasm of two apparently incompatible properties, the capacity to flow, and the possession of structural qualities necessary to satisfy elasticity and tensile strength. The biologist presents the problem. The physical-chemist must answer, if answer

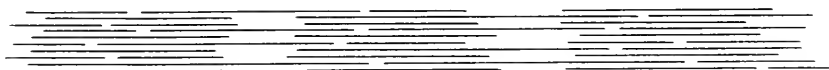

FIG. 5

there is to be. He suggests loosely attached cross-linkages, such as those which are established by the hydrogen bond.

The problem of the simultaneous presence in organic systems of fluidity and structural continuity is one which confronts the chemist as much as the biologist. Highly branched, cross-linked, three-dimensional polymers always exhibit elasticity, though fluid.

Side chains which make lateral connections between molecules have long been recognized in stereochemistry. But the concept that one end of the link is loosely attached and the other firmly so is new, and of great biological importance. It has been suggested that variations in the degree of hydration of the side chains constitute a possible explanation of a weak attachment at one end. But it is another interpretation of this feeble union which I have selected, namely, the hydrogen bond.

In a chemical cycle, as in muscle, during which accessory molecules go in and out of combination with the side chains of the protein main chains, the latter take up a cycle of configurations. In all such dynamic systems, of which protoplasm is one, there is a constant shifting of ties between the structural units. The loose union which permits this is very probably a hydrogen bond. Linus Pauling⁶ believes this bond to be of greater significance for physiology than any other single structural feature. It serves our present purpose well because it is not a strong bond.

⁶ *The Nature of the Chemical Bond*, Ithaca, N. Y., 1940.

When an atom of hydrogen is attached to not one but two other atoms and thus acts as a tie between them, the union involves the hydrogen bond. In such a case, one of the points of attachment is a firm covalent bond, and the other a weaker one, essentially ionic in character. The latter is the hydrogen bond.

In general, the hydrogen bond is part of a situation in which hydrogen appears to have two valences, one stronger with some ionic character, the other weaker with more ionic character. The strength of the latter weaker bond ranges from one-tenth to one-hundredth that of the former, according to the atoms involved and their distance apart. Because it is feebly attached, the hydrogen bond shifts easily from one atom to another.

The use to which the hydrogen bond may be put in interpreting protoplasmic behavior in respect to structural continuity is illustrated in a simple system like water. For some time it has been known that the water molecule is polar, i. e., it has an electric moment. It possesses, therefore, the characteristics necessary for molecular orientation. The two hydrogen atoms are positively charged, and the oxygen atom is negatively charged. At a distance, such a molecule is electrically neutral, but viewed nearby, it is positive or negative depending on one's position. The negative oxygen atom of a water molecule will attract and hold the two positive hydrogen atoms of another water molecule, and with a force which may equal the hold on its own two hydrogen atoms. The valence bonds within a water molecule may be regarded as chemical and those between adjoining molecules as physical, but it amounts to essentially the same thing in the end, for the hydrogen atoms and the oxygen atoms exert forces on the surrounding molecules which are no less chemical in nature than those holding the atoms within the molecule together. Fluidity depends upon the shift that takes place between one molecule and another. Water molecules are always in partnership, but always changing partners. We thus see how polarity leads to orientation and it in turn to continuity in structure in liquid systems. That this is true is indicated by the diffraction patterns which certain solutions yield, indicative of some kind of arrangement.

In a somewhat similar manner, Pauling interprets the structural continuity of water in terms of the hydrogen bond. Instead of the classical H_2O , it is presumed that each oxygen in water is surrounded by four hydrogens, two of which, close to the oxygen atoms, are

joined to it by primary valences, and two, farther away, by the hydrogen bond.

The situation existing in water is even more applicable to proteins where structural possibilities are infinitely greater; and proteins are the building material of protoplasm. In amino acids the nitrogen atom has one open coordinate position with which it may unite to a hydrogen in the same or another molecule. This union is a hydrogen bond; it may join the nitrogens of two amino acids.

The essential feature of the hydrogen bond, insofar as our present problem is involved, is its ease in shifting. This permits fluidity while maintaining continuity in structure. But protoplasm does not flow with equal ease at all times; it is often of high viscosity, and it may be firm. The lateral bonds are therefore more securely held at one time than at another, and at still other times they are tightly locked, wholly preventing flow. If the hydrogen bond is to satisfy these conditions, it must show considerable variability in firmness, from a feeble contact permitting ready readjustment, to a firm grip tightly locking the fibrous units of the living three-dimensional lattice. Pauling points out that firmness of the hydrogen bond varies with the electronegativity of the atom.

As one of the essential points of this discussion is the variability in firmness of the weaker end of cross-chains, I want to dwell upon it just a moment longer in order to emphasize an important difference between such a variability in nonliving and in living systems. Usually, variability in the viscosity, elasticity, and tensile strength of a solution of nonliving chain polymers is accomplished simply by changing the concentration. At high concentration the chains will join at more points. But in protoplasm the "concentration" remains the same, yet the physical properties vary. This is accomplished by change in the firmness of the cross-ties. How this change can come about has been suggested. There is the further possibility that some protons are added or subtracted with change in pH, forming or breaking hydrogen bonds; change in salt concentration might also alter their strengths.

The hydrogen bond thus provides a mechanism by means of which continuity in structure, elasticity, and rapid changes in viscosity in protoplasm may be explained.

Astbury⁷ calls attention to another attribute of the hydrogen

⁷The hydrogen bond in protein structure, *Trans. Faraday Soc.* 34:871-880, 1940.

bond, namely, its probable function in the hydration of proteins. Water of hydration is not our present interest, though an important subject in biology. Reference is made to it in order to show further application of the hydrogen bond.

The hydrogen bond will probably serve the biologist well in his studies on the mechanism of protoplasmic behavior. But the physical chemist promises still more for the future. Pauling⁶ calls attention to resonance as a likely factor in the physiological activities of living matter. Resonance describes the state of a molecule when one of several alternate structures are possible, and the actual normal state of the molecule is not represented by any one, but by a combination of them. The molecule is then said to resonate among the several possible electronic or valence-bond structures.

Little has as yet been done with resonance in the interpretation of vital processes. The future of it in biology cannot, therefore, be predicted with certainty, but it opens up a great field of possibilities.

The biologist is confronted with many qualities of living matter which will remain pure physiological problems for some time to come, but the list of properties which are now fully or partially capable of pure physical or chemical analysis is a long one; it includes elasticity, tensile strength, contractility, thixotropy, gelation, fluidity, non-Newtonian behavior, streaming, amoeboid movement, structural continuity, birefringence, symmetry, asymmetry, spirality, liquid crystallinity, and selectivity.

It is truly an encouraging sign in the progress of science when properties of protoplasm such as contractility and structural organization, which heretofore were so little understood, can now be interpreted in terms of folded polypeptide fibers, interlocking side chains, hydrogen bonds, and asymmetry of the carbon atom.

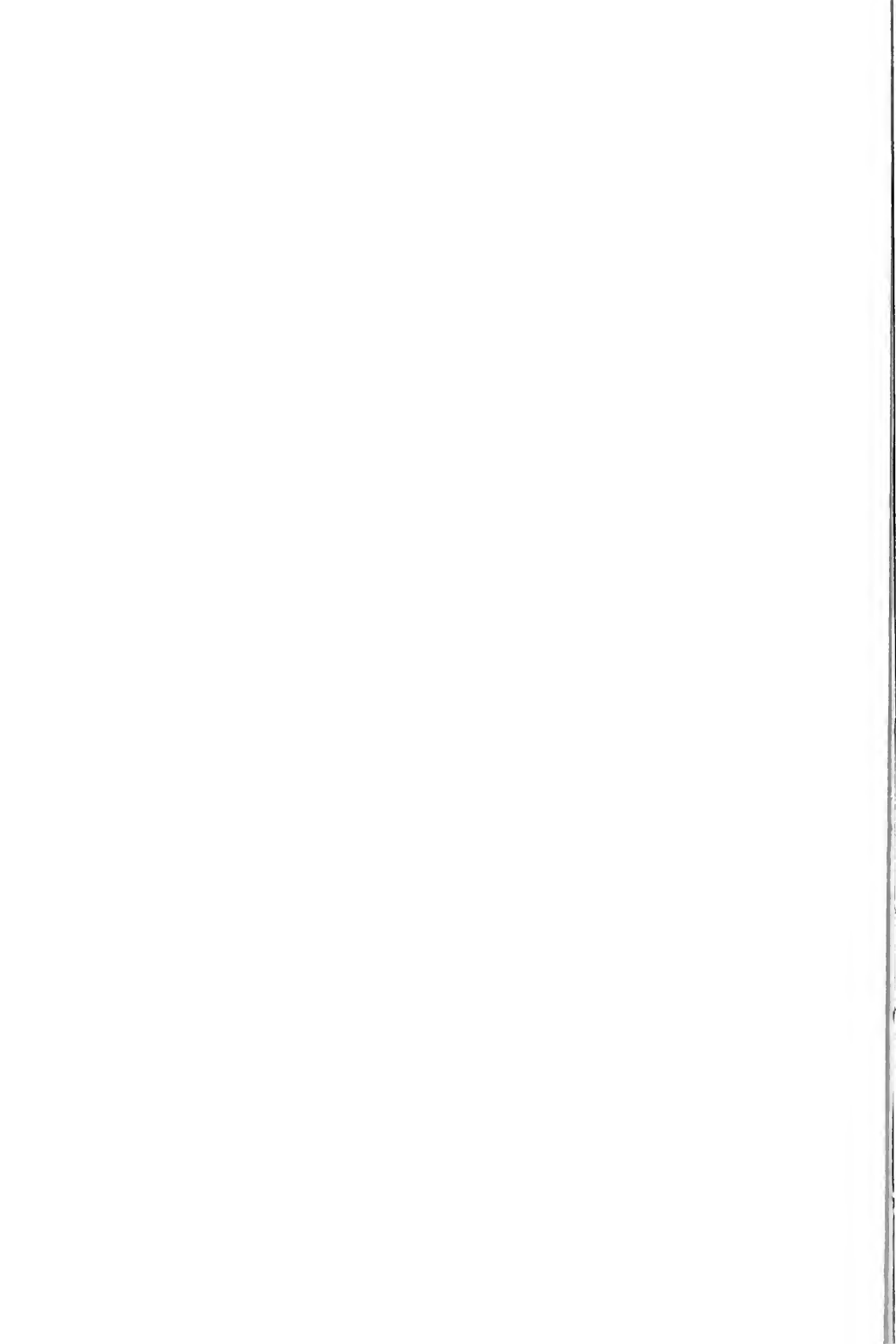

MICROSCOPIC STRUCTURE OF THE CELL WALL

CHARLES W. HOCK

*Research Associate of the Textile Foundation, National Bureau of Standards,
Washington, D. C.*

Past discussions on the cell wall (1, 7, 12, 23, 26) have indicated that a detailed knowledge of its structure will aid in the solution of many botanical problems. Although there is a tendency to concentrate attention on the protoplast as the fundamental unit of the plant, there can be no doubt but that the wall surrounding this unit plays a role of considerable importance in its life. Since deposition of the wall appears to be closely associated with protoplasmic activity, a clear perception of its structure may be helpful in understanding the structure and behavior of protoplasm.

The walls of plant cells exhibit diverse structural patterns depending upon the orientation of the cellulose and other constituents of which the wall is composed. Excellent photomicrographs of cell walls which exhibit concentric, radial, ramifying, or even more complex patterns, have already been published (4, 5). In spite of such differences, walls from various sources show certain similarities in structure which appear to be fundamental. Accordingly, a detailed description of the microscopic structure of a particular cell wall may serve as a basis for comparison with other types.

Because of its economic importance the attention of many investigators has been directed toward a study of the cotton fiber. As a result, considerable information concerning the structure and behavior of its cell wall is available. Furthermore, as material for the study of cellulose deposition, cotton fibers possess several advantages. On the day of flowering, or thereabouts, cotton fibers originate as single-celled outgrowths of epidermal cells of the seed coat, and their growth history can be traced daily thereafter. Where fibers arise as part of a complex tissue, as is the case with wood and bast fibers, the time of their origin is unknown, and their development cannot be followed so readily.

The first evidence of the origin of cotton fibers is the appearance on the day of flowering of a swelling on the outer wall of the epidermal cells of the seed coat. The tubular outgrowths thus

formed elongate rapidly for a period of 15 to 20 days, when growth in length ceases. In accordance with the description by Anderson and Kerr (2), the thin wall which encloses the protoplasm of the cotton hair during this period of elongation is called the *primary wall*. After growth in length ceases the thickness of the wall is increased by a deposition of cellulose which comprises the *secondary wall*. In discussing the structure of cell walls it is essential to differentiate clearly between the primary and the secondary wall. Since, in cotton fibers, deposition of the latter does not begin until from 15 to 20 days after the fibers originate, young fibers are ideal for studying the structure of the primary wall.

When young fibers with primary wall only are examined microscopically with ordinary light, there is no evidence of structure in the wall. The latter stains deeply and uniformly with ruthenium red which, although not specific for pectic substances, is a satisfactory presumptive test (2). On examination with crossed nicols, unstained primary walls show a low order of birefringence with colors indicative of a predominantly transverse orientation (11, 17). Although these fibers show only slight birefringence when unstained, they are clearly anisotropic after treatment with a cellulose dye such as Congo red. This increase in birefringence upon staining is due, apparently, to the double refraction of the dye molecules which are preferentially adsorbed by the small amount of cellulose which is present (12, 21). Although a number of investigators have suggested that the skeletal material in the primary wall is not cellulose but a closely related substance, X-ray investigations (11, 28), staining reactions (2, 17), and behavior in cuprammonium hydroxide solutions (2, 17) indicate that it is probably cellulosic in nature.

The cellulose in the primary wall of the cotton fiber has been shown (2, 9, 10, 17) to be present as criss-crossing strands which have a netlike arrangement (Fig. 1, A and B). The reticulate structure of the cellulose appears to become coarser and to show greater birefringence as the wall increases in age (compare Fig. 1, A and B). Likewise, the angle which the criss-crossing cellulose strands make with the axis of the fiber appears to be greater at the tip than at the base. These facts suggest that growth and expansion of the primary wall involve the separation of fibrils and the deposition of new cellulose strands between them.

Cellulose is not, however, the only constituent of the primary wall. The latter also contains wax and pectic materials which may

be detected by applying various stains to the fiber (2, 17), as well as by direct chemical analysis (29). When young fibers are purified by the removal of wax and pectin, the delicate framework of cellulose always remains. It appears, therefore, that the primary wall is made up of a tenuous network of cellulose embedded in relatively large amounts of wax and pectic substances. There is evidence which indicates that the structure of the primary wall of

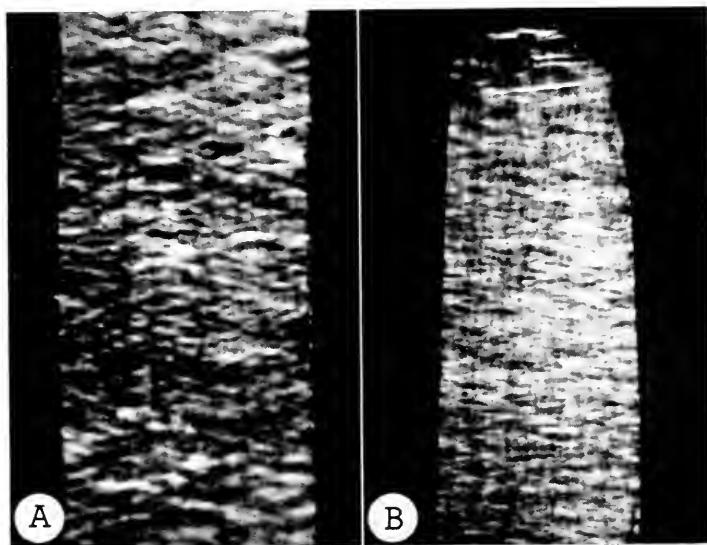

FIG. 1. Fibers stained with Congo red and photographed between crossed nicols to show the strands of cellulose in the primary wall. A. Part of a 15-day fiber placed at 45° with respect to the planes of the nicols. B. Tip of a 3-day fiber placed at 45° with respect to the planes of the nicols. Magnification $\times 890$.

cotton is similar to that found in other plant cells (5). The orientation of the fibrils varies in different cells, diverse types showing, however, a fundamentally similar structure.

Although the coarser details of the structure of the secondary wall are often visible in unswollen material, the pattern is studied to best advantage in expanded sections. By the use of suitable swelling agents details of structure which could not be detected otherwise, are rendered microscopically visible. Use of the swelling technique in conjunction with X-ray data and polarization studies offers a satisfactory method for observing the structure of the cell wall.

When mature cotton fibers are placed in cuprammonium hydroxide solution, or Schweizer's reagent, they immediately begin to swell and twist, the rapid expansion of the cellulose of the secondary wall usually resulting in the rupture of the primary wall. As the cellulose pushes through the tears in the latter, expanded regions resembling beads appear along the axis of the fiber (Fig. 2). After a short time in the reagent, however, the



FIG. 2. Mature cotton fiber in cuprammonium hydroxide solution, showing irregular swelling due to the constricting influence of the primary wall. Magnification $\times 120$.

cellulose dissolves completely, leaving a residue which consists principally of fragments of the primary wall, and to a lesser extent of material from the lumen (16). This residue is isotropic, and chemical analysis indicates that it consists largely of wax and pectic substance (29). Full-strength cuprammonium reagent dissolves the cellulose of the fibers in a relatively short time, leaving no microscopically resolvable particles of cellulose (16). Dilute solutions of the reagent, on the other hand, swell the fibers greatly, but

FIG. 3. Cross sections of cotton fibers swollen in cuprammonium hydroxide solution to show the layered structure of the secondary wall. A. Section of a 25-day fiber. Magnification $\times 950$. B. Section of a mature fiber from an open boll. Magnification $\times 420$. C. Section of 26-day fiber showing lamellae, photographed between crossed nicols. Magnification $\times 700$.



A

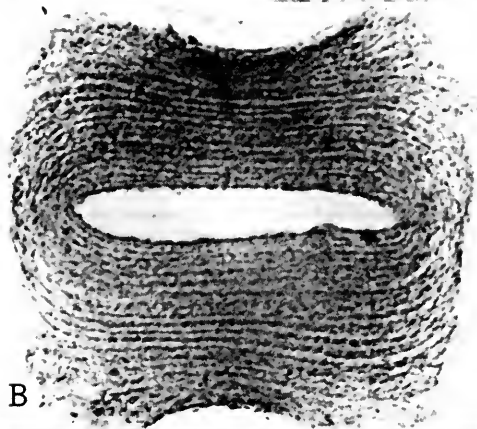

B



C

dissolution of the cellulose is retarded. Fibers swollen in this way can be used for observing details of structure.

Swollen cross sections of cotton fibers clearly reveal a lamellate pattern. On treating the swollen sections with a dye such as Congo red, alternating layers appear to be deeply and lightly stained (Fig.



FIG. 4. Longitudinal view of the layers in the secondary wall of a swollen 51-day fiber. Magnification $\times 500$.

3, A and B), and between crossed nicols the alternating layers are strong and weakly birefringent (Fig. 3,C). This layered structure of the secondary wall can also be observed in longitudinal view (Fig. 4), where stripes running parallel to the fiber axis, and extending from the lumen to the primary wall, can be seen. The first layer is laid down on the day when secondary thickening is initiated, the number increasing thereafter as the fiber approaches maturity. This increase in the number of layers with increase in age of fiber can be seen by comparing Figure 3,A with Figure 3,B.

According to Kerr (20), two adjacent layers, one compact and one porous, are deposited every 24 hours during the period of secondary wall deposition. Two adjacent layers together, therefore, constitute a daily "growth ring." The denser of the two layers which comprises each ring was found to be laid down during the day, the other at night. Counts of rings in fibers of different ages indicate that after the start of secondary growth, one ring is laid down per day until the fiber reaches maturity (14, 20). The width of individual growth rings in unswollen fibers varies from 0.1 to 0.5 micron. The width of the growth rings appears to fluctuate with

variations in environmental conditions. For certain localities at least, variations in temperature and the width of the growth rings can be correlated (19). Thus, cotton fibers from different plants, but grown under the same conditions, show similar rings, so that

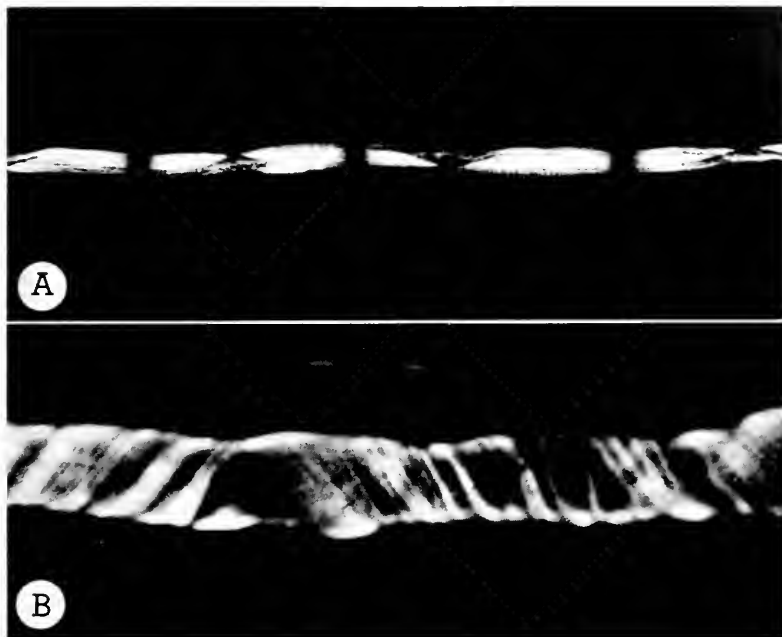

FIG. 5. A. Mature fiber mounted in water and photographed between crossed nicols to show the bands of extinction where the fibrillar orientation reverses. Magnification $\times 180$. B. A swollen fiber, photographed between crossed nicols, showing a reversal in the direction of orientation of the first layer of fibrils in the secondary wall. Magnification $\times 420$.

it is possible to cross-date daily growth rings of cotton just as annual rings are cross-dated in the trunks of certain trees.

Upon examination of single cotton fibers with crossed nicols, much can be learned about the orientation of the cellulose. When the fibers are placed approximately parallel to the plane of light passing through one of the nicol prisms, the high birefringence of the fibers is interrupted by dark extinction bands at irregular intervals along the axis (Fig. 5,A). These optical variations can be correlated with differences in structure observed in swollen fibers. Upon swelling, the latter clearly reveal a fibrillar structure (Fig.

5,B, and 6,A and B). The bulk of the fiber is made up of innumerable fine fibrils oriented at an acute angle with respect to the axis of the fiber. The fibrils make either an "S" or "Z" twist¹, reversal of direction (Fig. 5,B) taking place many times in a single fiber. At least in certain types of cotton the direction of orientation of the fibrils in the first-formed layer of the secondary wall is opposite

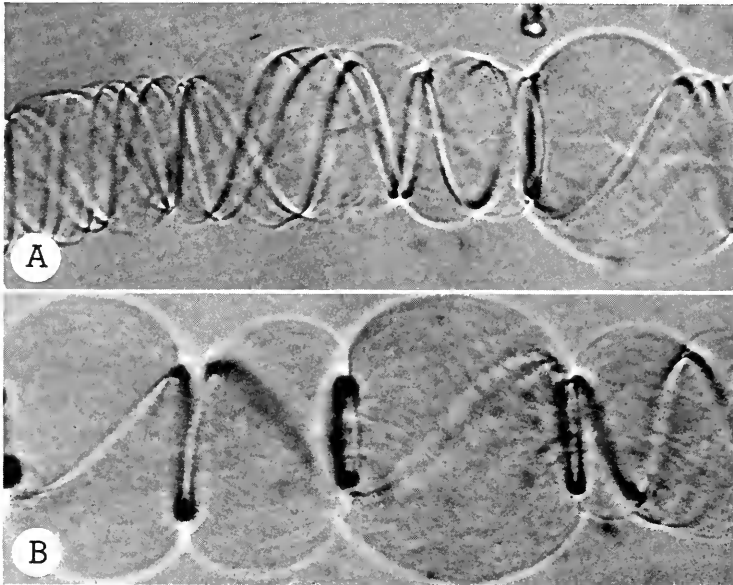

FIG. 6. Fibers, free of wax and pectic substance, swollen in dilute cuprammonium hydroxide solution. A. Showing differences in orientation between the first layer of fibrils and those subsequently deposited in the secondary wall. B. Irregular swelling caused by the constricting influence of the outermost layer of fibrils which has become clumped at various points along the axis of the fiber. Magnification $\times 420$.

from that in layers which are laid down thereafter (Fig. 6,A). In other words, if the first layer of fibrils makes an "S" twist, all the fibrils formed in subsequent layers make a "Z" twist. Under certain conditions of swelling, the outer layer of fibrils exerts a constricting influence on the expanding inner layers of cellulose (Fig. 6,A and B). The fibrillar orientation in cotton seems to be less complicated than in *Valonia* where the wall consists of some

¹ The fibrils are said to show an "S" twist if, when the fiber is held in a vertical position, the spiral of the fibrils conforms in slope to the central portion of the letter "S" and a "Z" twist if the spiral conforms in slope to the central portion of the letter "Z."

thirty layers, with the fibrils in alternate layers at a definite angle to each other (22). In cotton, when the outermost layer of fibrils changes its direction of winding, all the inner layers do likewise. It is readily apparent that these reversals of direction of the cellulose fibrils are responsible for the optical differences observed with

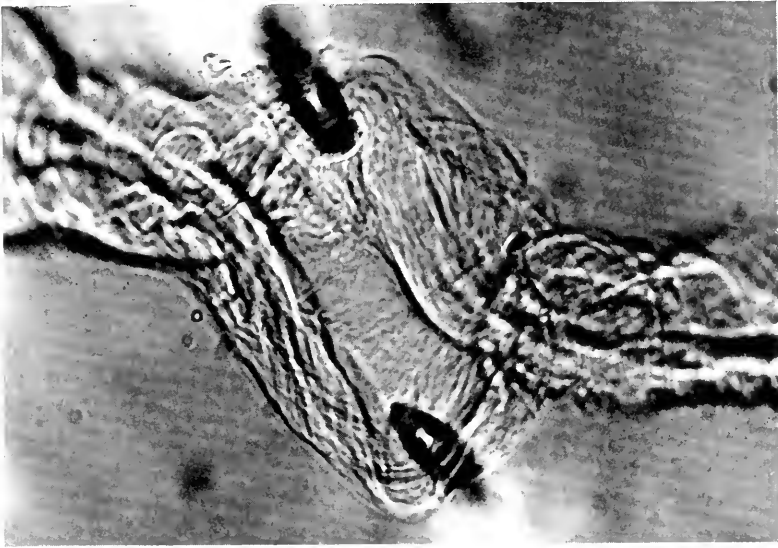

FIG. 7. A single swollen fiber being dissected with microneedles to show its fibrillar structure. Magnification $\times 500$.

crossed nicols and that the band of extinction is the place at which the reversals occur. It can be shown, moreover, that the number of extinction bands in a single fiber invariably corresponds to the number of fibril reversals.

Many investigators (3, 8, 14, 15, 16, 17, 18, 22, 24) have called attention to fibrils in the walls of widely different plant cells. There is evidence, also, that the striations detectable in the intact wall are related to the fibrils observed in the swollen material. A comparison of the work of Anderson and Kerr (2) with that of Berkley (11), and the work of Astbury and Preston (3) shows, moreover, that the cellulose molecules are oriented approximately parallel to the long axis of the fibrils. Although a variety of physical and chemical treatments reveal the presence of fibrils in the cell wall, probably no method gives a more convincing demonstration of their presence than microdissection. Upon handling cotton fibers with micro-

needles, the fine fibrils which comprise the secondary wall can easily be separated from one another (Fig. 7).

In the cotton fiber the fibrils are grouped to give a layered pattern. In an expanded transverse section they may be observed as more or less round bodies (Fig. 3, A and B). In the denser layers of the wall there are, presumably, more fibrils per unit area than in the more porous layers which are deposited during the day. Although the secondary wall appears to be resolved into a system of fine fibrils, it is unlikely that the fibrils are uniform and discrete morphological units of constant dimensions. Their presence is, however, indicative of the fibrous structure of the wall and the manner in which it was deposited.

In the case of a heavily lignified secondary wall, it is possible to remove the cellulose and leave a firmly coherent residue of lignin, and conversely, it is possible to remove the lignin and leave the cellulosic matrix. Following Frey-Wyssling's (13) conception of the submicroscopic structure of cellulose (recently supported by additional evidence from studies involving use of the electron microscope (25)), Bailey (6) has suggested a similar configuration for the finer visible structure of swollen secondary walls. According to this viewpoint the secondary wall consists of a matrix of cellulose fibrils interpenetrated by a system of interconnecting capillaries which commonly contain pectic substances, hemicelluloses, lignin, cutin, suberin, and other organic compounds. The visible pattern of a wall may, therefore, be caused by variations in the orientation of the cellulose fibrils, and also by variations in the amount and arrangement of organic substances which are deposited between the fibrils.

REFERENCES

1. ANDERSON, D. B. 1935. *Bot. Rev.* 1, 52.
2. ANDERSON, D. B., AND KERR, T. 1938. *Ind. Eng. Chem.* 30, 48.
3. ASTBURY, W. T., AND PRESTON, R. D. 1940. *Proc. Roy. Soc. B* 854, 54.
4. BAILEY, I. W., AND KERR, T. 1935. *Jour. Arnold Arboretum* 16, 223.
5. BAILEY, I. W. 1938. *Ind. Eng. Chem.* 30, 40.
6. BAILEY, I. W. 1939. *Bul. Torrey Botanical Club* 66, 20.
7. BAILEY, I. W. 1940. *The Walls of Plant Cells* in "The Cell and Protoplasm," Lancaster, The Science Press.
8. BALLS, W. L. 1922. *Proc. Roy. Soc. B* 93, 426.
9. BALLS, W. L. 1923. *Proc. Roy. Soc. (London)* B 72, 72.
10. BALLS, W. L. 1928. *Studies of Quality in Cotton*, Macmillan & Co., Ltd., London.
11. BERKLEY, E. E. 1939. *Textile Research* 9, 355.

12. FREY-WYSSLING, A. 1935. *Die Stoffausscheidung der Höheren Pflanzen*, Berlin, Julius Springer.
13. FREY-WYSSLING, A. 1937. *Protoplasma*, 27, 372, and 566.
14. HERZOG, R. O., AND JANCKE, W. 1928. *Zeitschr. phys. Chem. A* 139, 235.
15. HOCK, C. W., AND SEIFRIZ, W. 1939. *Paper Trade Jour.* 110, T53.
16. HOCK, C. W., AND HARRIS, M. 1940. *Jour. Res. Nat. Bur. Standards* 24, 743.
17. HOCK, C. W., RAMSAY, R. C., AND HARRIS, M. 1941. *Jour. Res. Nat. Bur. Standards* 26, 93.
18. ITERSON, G. VAN. 1933. *Chem. Weekbl.* 30, 6.
19. KERR, T., AND BAILEY, I. W. 1934. *Jour. Arnold Arboretum* 15, 327.
20. KERR, T. 1932. *Protoplasma* 27, 229.
21. MOREY, R. D. 1933. *Textile Research* 3, 325.
22. PRESTON, R. D., AND ASTBURY, W. T. 1937. *Proc. Roy. Soc. B* 826, 76.
23. PRESTON, R. D. 1939. *Biol. Revs.* 14, 281.
24. RITTER, G. 1928. *Ind. Eng. Chem.* 20, 941.
25. RUSKA, N., AND KRETSCHMER, M. 1940. *Kolloid. Zeitschr.* 93, 163.
26. SEIFRIZ, W. 1934. *Protoplasma* 21, 129.
27. SEIFRIZ, W., AND HOCK, C. W. 1936. *Paper Trade Jour.* 102, T250.
28. SISSON, W. A. 1937. *Contrib. Boyce Thompson Inst.* 8, 389.
29. WHISTLER, R. L., MARTIN, A. R., AND HARRIS, M. 1940. *Jour. Res. Nat. Bur. Standards* 24, 555.

11

12



PROTEINS AND PROTOPLASMIC STRUCTURE

LAURENCE S. MOYER

Department of Botany, University of Minnesota

It is obvious that some kinds of protoplasm, such as the chromosomes, have an intricate structure, but in the case of morphologically undifferentiated cytoplasm it is not self-evident that structure is present. It will be the purpose of this chapter to correlate recent results in this field with what is known about proteins. No attempt will be made here to discuss specialized structures such as the cell membrane.

The physiological behavior of protoplasm indicates the presence of some sort of structural continuity. Led by a desire to interpret its properties in terms of structure, numerous investigators have turned to the microscope for aid, yet have achieved little success. For, under the microscope, protoplasm appears, to use the words of von Mohl (27), as "niemals einen klaren wässerigen Zellsaft . . . sondern . . . eine zähflüssige, mit feinen Körnchen gemengte, ungefärbte Masse." His description, it will be noticed, stresses its gelatinous consistency. Later observers of living protoplasm have emphasized the presence of emulsion droplets and granules but have really left the subject of protoplasmic *structure* as obscure as before; for it is hard to imagine how a disperse phase can furnish the continuity needed to transmit stimuli. In any case, it has been found that optically clear protoplasm can remain alive. Thus, an amoeba may extend a pseudopodium free from granules. This can be cut off with a microdissection needle yet retains its irritability for a time (7). Harvey (15) centrifuged sea urchin eggs into two or more parts, one with the nucleus and the fat droplets, the other with the pigment granules, yet each could be activated by chemical treatment resulting in parthenogenetic cleavage. Thus it appears that neither the nucleus nor the granules is needed to bring about cell division. Hence it is generally realized that the hyaline, continuous phase hides the answer to the problem.

The mere fact that the hyaloplasm is optically empty does not signify that it is structureless. For instance, the nuclei in the pancreas of the white mouse cannot be seen in the living cells although

fixation reveals their presence (16). The nuclei of many other animal cells are optically empty (7), yet it would be foolhardy to claim to a geneticist that no genic arrangement or differentiation is present. Many other such cases in which the refractive indices of cell constituents are too much alike to form visible edges can be cited.

DOUBLE REFRACTION OF PROTOPLASM

Fortunately, there are other approaches to the problem than by the use of the microscope alone. Of these, polarized light has been employed with considerable success.¹ It has long been known that muscle, nerve, sperm, and certain other specialized cells are doubly refractive (41). Likewise, chromosomes, chloroplasts, and other cell constituents may exhibit this property (41). The question arises: Is this birefringence due to the presence of anisotropic particles (intrinsic double refraction) or is it produced by the regular arrangement of isotropic rods or plates in an isotropic medium of different index of refraction (form double refraction)? It follows from the theory of Wiener that the presence of form birefringence in an object can be detected by varying the refractive index of the medium bathing the particles, whereupon the magnitude of the double refraction changes, until, at a certain refractive index, the object appears isotropic, i. e., dark in all positions between crossed nicols. On raising the refractive index of the medium beyond this point, the form birefringence reappears. If, however, the object is intrinsically anisotropic, this disappearance of birefringence does not take place, and the extent of the double refraction does not depend on the refractive index of the medium. Upon the application of this test to intracellular structures, it has been found that, although form birefringence (generally rod birefringence) may be present, some intrinsic double refraction may be superimposed on it. Under such conditions, the curve of double refraction of the object vs. refractive index of the medium reaches a minimum but does not drop to zero. Since, in general, it is not possible to carry out this procedure on living material and since one must assume that the imbibing medium does not interact with the micells, its use with protoplasm is limited. At all events, when an object appears bright between crossed nicols it is clear that oriented anisodiametric particles are present.

Although chromosomes, chloroplasts, and other specialized structures exhibit definite birefringence, attempts to detect double refrac-

tion in areas of morphologically undifferentiated cytoplasm were at first without success. To some extent, this was due to the thinness of the object and the consequent small magnitude of the phase difference. Introduction of more sensitive compensators and the use of higher light intensities has largely removed this difficulty and has made it possible to detect double refraction even in extremely thin strands such as spindle fibers (41). With these refinements in technique, numerous investigators have succeeded in showing the presence of doubly refractive elements in cytoplasm itself, as well as in the spindle fibers, cilia, and plasma membrane (41, 42). Inasmuch as orientation of anisodiametric particles enhances double refraction, it might be expected that streaming cytoplasm would exhibit more brilliant birefringence than in the quiescent state, just as solutions of myosin or tobacco mosaic virus become bright under crossed nicols when streaming through a tube (9). A consideration of the magnitude of the shearing stress needed to produce noticeable streaming double refraction in sols under experimental conditions suggests that the low velocities encountered in cyclosis would hardly be enough to cause sufficient orientation of submicroscopic protoplasmic particles. This seems to be the case, for such effects do not appear to have been reported.

On the other hand, it is well known that many substances composed of rod-shaped particles, e. g., a gelatin gel, can be statistically isotropic and yield the same mean value of the refractive index in all directions, due to random arrangement of the micells. Any force causing orientation of the micells produces birefringence under such conditions. Engelmann (10) pointed out long ago that apparent isotropy of cytoplasm is not proof for the absence of doubly refractive micells. Although cytoplasm may appear isotropic, pseudopodia extended from it are often brightly birefringent (41). The birefringence persists for a short distance into the mass of the cytoplasm and then disappears. If the pseudopodium is retracted, the anisotropy fades away. When amoebae are rounding up before encysting, the double refraction is much more definite (41). The spindle arising during mitosis has been reported to be anisotropic in the living condition by several observers (41). In these cases it is probable that orientation of micells has been produced by activity.

As predicted by statistical mechanics, a system tends to assume the most thermodynamically probable state when left to itself. In substances such as rubber, which possess long-chain, flexible molecules, the completely extended state is only one among the many

possible configurations of the molecule and, hence, will occur very infrequently under these conditions (18, 21). Stretching the system can be made to produce extension and alignment of the flexible chains with a lessening of the probability of the system and a concomitant decrease in the entropy. Double refraction first appears on deformation. When the stress is released, thermal agitation of the different parts of the chain tends to produce more random configurations and a more probable state. Contraction results as the chains coil up. Likewise, in a system of inflexible rods, a random arrangement is most probable. In either case, cooling would tend to produce a more oriented, and warming, a more disoriented state. It is therefore especially interesting that Ullrich (47) has succeeded in producing double refraction in the cytoplasm of the epidermal cells of the bulb scale leaves of onion by cooling the tissue to 2°C. On warming the tissue to 3° or 4°C., the effect disappeared. He reports that death of the cells produced a sudden isotropy, so that it is doubtful if the double refraction can be ascribed to injury.

With the exception of the cell membranes, the continuous phase of protoplasm is aqueous. Several investigators (17, 38) have found that water injected into cytoplasm is taken up by it without vacuole formation. In many cases, it is probable that the high concentration of water in protoplasm and the resultant hydration of the micells interferes with double refraction phenomena. Rinne (39) has emphasized that the high dielectric constant of water tends to produce a weakening of the electrochemical fields of force between micells and reduce birefringence. In support of this, he has pointed out that the double refraction of the myelin sheath of nerve decreases as the water content increases, even though it is evident that the orientation of its micells persists, as indicated by the retention of its form. Ullrich (47) has also found that a reduction in the water content of protoplasm, brought about by plasmolysis with hypertonic salt or sugar solutions, produced birefringence in onion cell cytoplasm.

ADDITIONAL EVIDENCE FOR ROD-SHAPED BODIES

The observations made with the polarizing microscope indicate clearly that submicroscopic rods of some sort are present in cytoplasm, but they do not tell what the rods are or if any actual structure is conferred on the protoplasm by their presence. Fortunately, other experimental methods have been employed.

For instance, Moore (28) has found that the coenocytic plas-

modia of Myxomycetes could grow through pores in fine filter paper averaging 1 μ . If, however, a plasmodium was forcibly pressed through bolting silk, the resulting pieces had to be larger than 200 μ to remain alive. Retardation of growth was noticed when the diameter of the pores was less than 750 μ . He suggests that pre-formed rods, longer than 200 μ and composed of submicroscopic elements, are present in the protoplasm. Moore concludes that if these are broken up or removed, life ceases. Centrifuging at 75,000 gravities for 5 minutes likewise retarded proliferation. This he interprets as due to separation of these larger elements. On resting for a sufficient time, it appeared that structure was re-established, for proliferation began again. Here is an indication that not only are long rod-shaped particles present, but also that they play a role in the economy of the cell.

At once the question arises, what is the chemical nature of these particles? Of all substances present in protoplasm capable of aggregating to form such rods, the most prominent place is held by the proteins. From the time of Reinke, all of the gross analyses of protoplasm have emphasized the dominant position of the proteins. With proteins making up so large a part of its substance, it would be anticipated that they would exert a great influence upon its characteristics. Let us compare what is known of their properties with the properties of protoplasm.

GENERAL STRUCTURAL FEATURES OF PROTEINS

Recent work permits us to classify the proteins in two chief groups: (1) the fibrous or extended proteins, such as wool, and (2) the corpuscular or highly folded proteins, such as egg albumin. Members of both groups are constructed from the same kinds of amino acids. These appear to be joined into chains by peptide linkages to form what Astbury (3) has designated the "backbone" structure (Fig. 1). While the backbone of silk is apparently fully extended, in other protein fibers, such as hair and muscle, it is folded somewhat, as shown by their X-ray spacings. The individual properties of proteins are dependent on their side chains. In a fiber, adjacent backbones appear to be held together by bonds of various strengths. These bonds are due to interactions of the side chains (R , R' , R'' , . . . , in Fig. 1) branching off from the backbone. These are of diversified chemical nature (Fig. 2). Some are lipophilic (leucine) while others are hydrophilic (aspartic acid, tyrosine, and lysine). Of the latter group, aspartic acid is an example of an acidic amino acid while

lysine is basic. These, and similar, side chains bestow upon proteins their amphoteric properties. The presence of free lipophilic (hydrophobic) side chains in most fibrous proteins probably prevents them from being dispersed by water.

In the corpuscular proteins, however, it appears that the folding of the backbone is more complete, with most of the nonpolar side

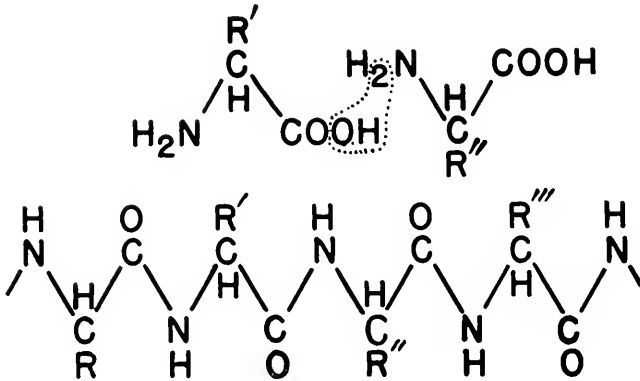

FIG. 1. Back-bone structure produced by the union of amino acids through the peptide linkage.

chains held inside and the polar groups sticking out on the surface. There is no unanimity of opinion as to the mechanism of the folding process, but it is probable that weak bonds, such as hydrogen bonds (35), are formed and that these hold the structure together (26). This configuration of these proteins appears to confer upon them their water solubility. Recent measurements of sedimentation velocity, diffusion, viscosity, and electrophoretic mobility (1, 20, 32) have emphasized that few of the corpuscular proteins approach sphericity although their axial ratios are not usually very high.

It had been considered that the two groups were nearly independent, but now it appears from investigations of denaturation and X-ray structure that a corpuscular protein may be transformed into a member of the fibrous group (3). Denaturation produced by heat, spreading on a surface, or by chemical treatment, apparently unlocks the folded molecule so that it becomes extended (6, 25). The slight rise in the isoelectric point of egg albumin on denaturation (30) indicates a change in the strength or number of the amino and carboxyl groups, among other linkages (6, 26). After extension has

occurred, X-ray photographs show crystal patterns similar to those yielded by protein fibers.

Between the corpuscular and truly fibrous proteins are such proteins as the muscle protein, myosin, and tobacco mosaic virus. These, although so elongated that they exhibit streaming double refraction, are not completely extended and disperse readily in

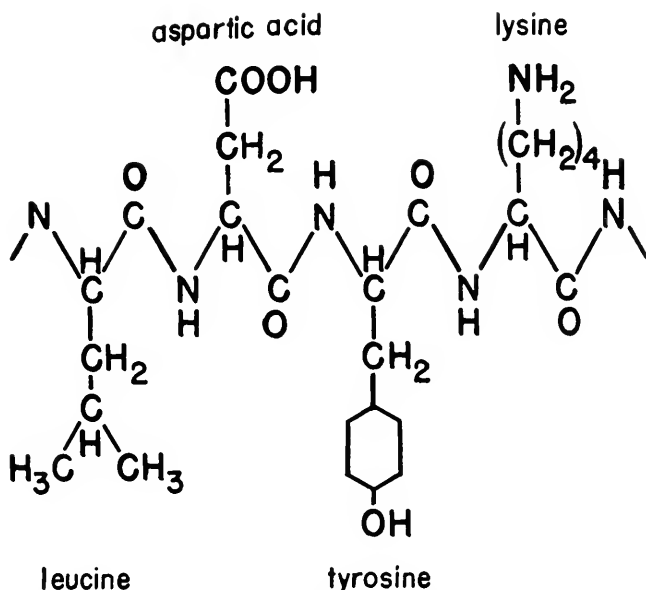

FIG. 2. Portion of a hypothetical protein molecule showing typical side chains.

aqueous solutions (9). The lability of proteins of this type has probably retarded the discovery of many similar examples.

PHYSICAL CHARACTERISTICS COMMON TO PROTEINS AND PROTOPLASM

Gel Formation. One of the properties of protoplasm is its capacity to exist as a gel. It is a striking characteristic of many of the more extended proteins that these too can form gels at low concentrations. Staudinger (46) has emphasized that it is not enough for a particle to be rod-shaped; to form a gel it must be able to form cross-linkages and a net structure. Chains of polystyrene are dispersed by organic solvents. Staudinger found that, if as little as 0.002 per cent

of divinyl-benzene was added to the styrene before polymerization, cross-linkages were produced. The resultant polymer, although indistinguishable by chemical tests from pure polystyrene, when placed in the same solvents swelled enormously but did not dissolve. In the case of a protein, like gelatin, gel formation depends on cross-linkages between the main chains. These bonds may vary in strength, from primary valence bonds, such as salt and disulfide linkages, to van der Waals' forces (13, 35, 44).

When collagen, the fibrous protein that constitutes connective tissue, is heated in water, it disperses to form gelatin. Gelatin forms statistically isotropic gels, yet, upon stretching these, the micells become extended and parallel. A gelatin gel that has been dried in the stretched state gives the X-ray pattern of a collagen fiber (14). Under these conditions, it is optically anisotropic and has a maximal breaking strength in the direction parallel to the axis along which it had been originally stretched. In other words, a fiber has been produced. The modern conception of the structure of an unstretched gelatin gel (37) would picture it as a tangle of chainlike molecules held together at certain points where chains cross (Fig. 3a). If portions of these molecules become oriented parallel to each other, a local anisotropy is set up (Fig. 3b). Stretching tends to produce a more orderly arrangement of longer portions of the chains until the statistically isotropic areas of the gel nearly disappear (Fig. 3c).

Seifriz (44) and, later, Frey-Wyssling (13) have proposed that a similar structure characterizes cytoplasm, except that the cross-linkages between the micells are constantly changing with changes in its local metabolic states. Perhaps it is well to emphasize here the importance of *local regions* in protoplasm. These become especially important when the question of shifts in bonds is considered. It is possible, for instance, to arrive at values for the mean oxidation-reduction potential or the pH of cytoplasm by the injection of suitable indicators. These overall values may be of considerable use when one cell is to be compared with another. But in the submicroscopic realm in protoplasm, such experiments lose significance. In the measurement of pH or oxidation-reduction potentials in nonliving systems, a state of equilibrium throughout the system is essential. It is obvious that living protoplasm is not in a state of equilibrium. It undoubtedly has some regions of quite different pH from other sections. For example, we have no right to predict from its overall pH value that the proteins in cytoplasm are above or below their isoelectric points, for it is possible that local changes in hydrogen-

ion activity can produce a local situation completely different from that occurring in a near-by region of the same cytoplasm. Yet it is the local conditions prevailing in this unstirred system that can bring about the formation or breakage of a bond between two adjacent protein molecules.

As local regions change under the influence of enzymatic action, radicals break apart and join to other groups or remain in the sol state for a time. It appears, however, that the framework can be

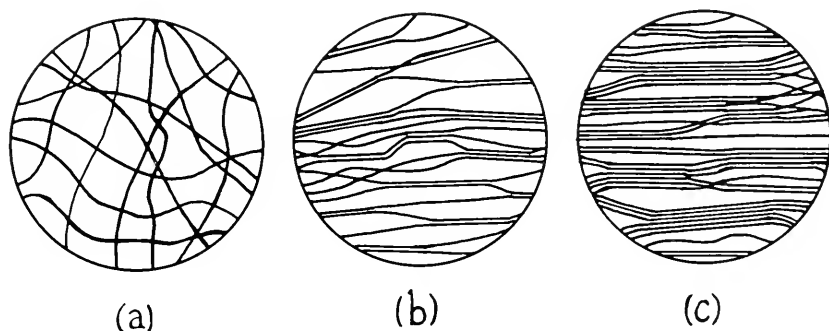

FIG. 3. Gel structure. (a) Statistical isotropy in unstretched gel. (b) Effects of moderate stretching. (c) Crystallite formation produced by extreme stretching.

readily reformed by gelation. Just as with nonliving gels, conditions inducing micellar orientation result in visible birefringence of the cytoplasm.

Reactions to Shearing Stresses. Gels, in general, exhibit structural viscosity at low rates of shear. That is, their rate of flow is not proportional to the shearing stress. When the shearing stress becomes great enough, the structure of the gel may be broken down so that it becomes a truly viscous sol. This has been observed with dilute gelatin gels by Freundlich and Abramson (11). On standing, these sols reverted isothermally into gels; in other words, they were also thixotropic. Not all gels exhibit this latter phenomenon, only gels capable of forming very loose interconnections.

Pfeiffer (36) has reported that protoplasm shows structural viscosity which depends on the rate of shear and that it, too, can be thixotropic. His experiments were performed by sucking protoplasm into a micropipette at various pressures. It has been observed by Chambers (7), among others, that agitation of the cytoplasm of a

marine ovum with a microdissection needle induced liquefaction. If the egg was allowed to rest, it appeared to revert to its original consistency.

Marsland, and Brown and Marsland (see, for instance, 19) have found that the application of high hydrostatic pressure inhibited cell motion, cell division, and protoplasmic streaming. As these properties diminished in extent with increasing pressure, there occurred a steady diminution in the structural viscosity of the plasmagel portion of the protoplasm, until, at high pressures, complete inhibition of these activities was attained and the viscosity curve reached a constant, low value. When the pressure was released, the cells reverted to normal. Marsland concludes that these physiological functions are linked to a reversible solation-gelation mechanism in the cell. Apparently the plasmagel of *Amoeba*, *Arbacia*, and *Elodea* cells shows structural viscosity as well as thixotropy.² From experiments with microdissection, Seifriz (44) has concluded that the consistency of protoplasm is not uniform but varies from species to species and with physiological states. Both he and Northen (33, 34) have presented evidence to show that protoplasm can have structural viscosity. Under these conditions, anomalous viscosity and thixotropy are strong evidence for a labile, micellar framework.

Elasticity. It is characteristic of many gels produced from rod-shaped particles that they have rubber-like high reversible extensibility, i. e., elastic properties. It was noticed by Freundlich and Seifriz (12), for instance, that only those soap solutions which contained rod-shaped aggregates were elastic. Gelatin (12, 14), elastoidin (37), elastin (21, 37), and collagen (14, 37), to name a few proteins, can all be brought into an elastic state. These are members of the fibrous or extended group.

In addition, both Scarth (40) and Seifriz (43, 44) have found that cytoplasm is elastic. For instance, Seifriz found that a nickel particle, which had been pulled through cytoplasm by a magnetic field, tended to revert to its initial position when the field was removed. Scarth has pointed out that cytoplasm can be elastic even while streaming. It was also observed by Seifriz that red blood cells on being stretched are highly elastic. Mudd and Mudd (31) have likewise observed a high reversible extensibility in normal leucocytes engaged in phagocytosis. Part of these latter phenomena may have been due to the membrane.

As mentioned above, when rubber-like substances are stretched, an extension of the molecular chains may take place without a change

in internal energy. If, however, the chains become oriented enough to produce crystallization, the internal energy decreases, due to the liberation of heat of crystallization (21, 37). In a normal elastic solid, such as a steel spring, stretching results in an increase in the internal energy by pulling the atoms out of their troughs of minimal potential energy. Thus, while rubber becomes warmer on being stretched, metals become cooler. This fundamental difference enables one to detect rod-shaped molecules. It has been established with the polarizing microscope and the X-ray that muscle owes its physiological properties to the elongated protein molecules of myosin (3, 37). It is especially interesting, therefore, that muscle fibers on contracting have been found to exhibit a thermal behavior completely similar to rubber (23). The contraction of muscle is thus due to a coiling up of its myosin molecules.

Spinning Capacity. It is well known that many proteins possess the capacity to be spun out into thin strands after denaturation. For instance, Meyer and Jeannerat (22) have found that long threads could be spun out from the viscous, liquid contents of the silk gland of the silkworm. Although the contents of the gland were soluble at pH 10, the threads were not. This indicates that they were denatured in the spinning. Such threads were reversibly extensible on stretching, but if held on a stretch for 10-30 seconds, crystallization of the micells took place and the elasticity disappeared. The stretched threads yielded a crystalline X-ray pattern, but the liquid silk was amorphous until it was dried. Seed globulins can be denatured in urea solutions and can then be spun out into elastic fibers (3). On stretching, the fibers crystallize in the fully extended form. It is interesting that these long chains were produced from corpuscular proteins.

Many workers have observed that plasmolysis may produce very long strands of protoplasm extending between the protoplast and the cell wall (cf. 13). After touching a plasmolyzed protoplast of onion with a microdissection needle, Seifriz and Plowe (45) drew out long, thin strands which were, in some cases, so fine as to be invisible, except for globules along their lengths. When the tension was released, the strands slowly contracted. It appears, therefore, as if the surface of a protoplast, at least, can be spun out like some proteins. Scarth (40) has likewise pointed out that strands of streaming protoplasm, when stretched by osmotic swelling, snapped and crumpled up like a solid thread, and then reverted to a fluid condition.

The evidence presented so far shows a close correlation between the behavior of protoplasm and the properties of proteins. It has been shown that protoplasm can behave like a thixotropic, plastic gel composed of elongated protein molecules arranged like a disorganized brush-heap, except when in certain active states. Obviously, not all protoplasm is the same; the lability of its framework permits it to exist in extremely liquid forms.

BEHAVIOR OF SEA URCHIN EGG PROTEINS AND MYOSIN

Properties of the Proteins. With the exception of myosin, the proteins we have discussed above have not been shown to take part in protoplasmic structure. It is, therefore, especially interesting that undenatured proteins involved in protoplasmic structure have been isolated by Mirsky (24) from the eggs of *Arbacia* and *Strongylocentrotus*. The eggs were frozen at $-77^{\circ}\text{C}.$, dried in vacuo, ground, and then extracted with cold 1 M KCl at pH 7.3. Mirsky found that about 83 per cent of the total protein in the egg could be dissolved by this method. If, however, the eggs had been fertilized, the soluble fraction would have been reduced to approximately 70 per cent. In other words, about 15 per cent of the soluble protein is rendered insoluble by the fertilization process.

Mirsky could show that the change in this protein fraction (which may not be a single protein) was not associated with cell division or the elevation of the fertilization membrane. The change in solubility occurred in an interval of 3 to 10 minutes after fertilization, with no further change detectable in the next 2 hours. It is, however, in this interval that the first cleavage occurs. Mirsky found that this decrease in solubility was accompanied by an increased strength and elasticity of the egg. The processes of freezing and thawing broke unfertilized eggs but did not break fertilized eggs frozen in this time interval. The fertilization membrane was not responsible for this phenomenon. He concludes that a skeleton framework, capable of supporting the cytoplasm during development, is produced by the alteration of this protein.³

To test these results, Moore and Miller (29) investigated the appearance of the *Strongylocentrotus* egg between crossed nicols. Its optical behavior was somewhat obscured by the cytoplasmic granules. After these had been moved to one side of the unfertilized egg by centrifugation, it was found that the hyaline cytoplasm was isotropic. If, however, the eggs were fertilized, the hyaloplasm became clearly birefringent within 3 minutes. This likewise suggests an orientation of structural elements.

Mirsky found it possible to isolate the labile protein fraction by salting out the soluble protein from unfertilized eggs with ammonium sulfate, whereupon the labile fraction came down first. It was then redissolved. The physical properties of this protein in its soluble state are precisely what might have been expected from the foregoing discussion of protoplasmic properties. At pH 7, it appears to be highly elongated. The viscosity of a 1.4 per cent solution was 9.6 times that of water. This value was influenced by the rate of shear, so that solutions of the protein exhibit structural viscosity. Unlike most of the corpuscular proteins, it showed streaming double refraction.⁴

Myosin is very like this protein in many respects. Its solutions show streaming double refraction and structural viscosity. They can readily be brought into a thixotropic state and exhibit marked elasticity (9, 25). When muscle is brought into rigor, its myosin becomes insoluble (25). It thus appears that the physical properties of two proteins associated with protoplasmic structure are strikingly similar.

Physical State of These Proteins. Changes induced in the corpuscular proteins by heat, acid, etc., usually involve two steps: (1) denaturation and (2) coagulation. In denaturing, the molecule unfolds and the viscosity of the solution is increased. The mechanism of this change is not clearly understood, but it is usually agreed (26, 35) that weak bonds, such as hydrogen bonds, holding the molecule together, are broken and the molecule becomes an extended structure, approximately 10 Å thick. The denatured product is not rendered insoluble until the pH of the solution is brought into the neighborhood of its isoelectric point, whereupon the protein coagulates and loses its solubility in water (6). This change is presumably the result of a side-by-side association after the net charge is decreased. In most cases, denaturation of these proteins is accompanied by a change in the number of sulfhydryl groups (25, 26).

The fibrous proteins, on the other hand, are considered to be already unfolded, i. e., denatured and coagulated. The X-ray investigations of Astbury (3) indicate that this unfolding varies in extent. Astbury believes that keratin, as it exists in unstretched mammalian hair, is in what he calls the α state. On stretching the hair, the backbones become completely extended (β keratin); if, however, relaxed hair is treated with steam, they become "supercontracted." These states may not be produced by such simple foldings of the back-

bone as Astbury had originally postulated, but the true state of affairs is probably somewhat like that shown in Figure 4.

Myosin and the protein isolated by Mirsky appear to have some characteristics of both groups. They are much more elongated than the corpuscular proteins, yet are soluble in water. Both show double

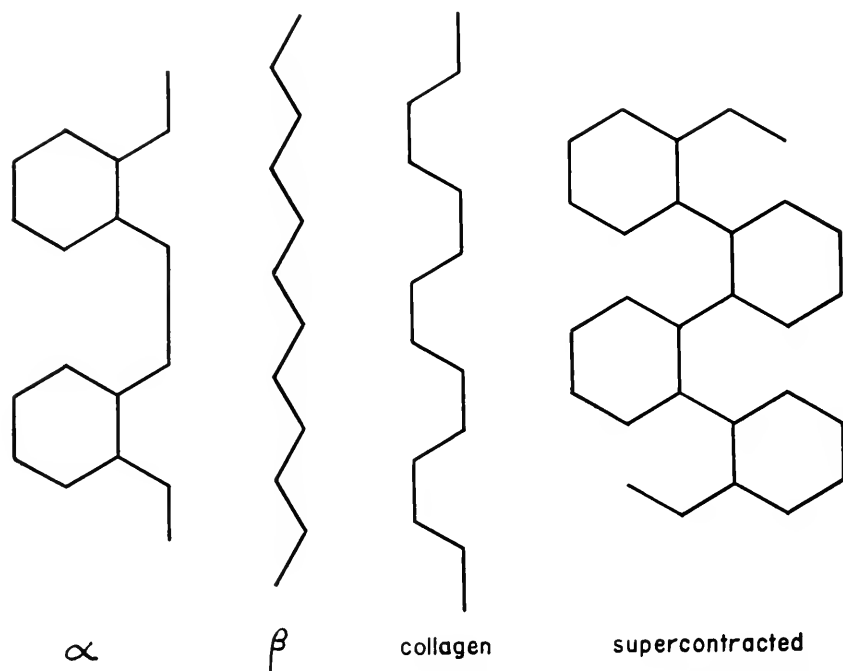

FIG. 4. Possible folded states of the back-bone in fibrous proteins. (After Astbury.)

refraction of flow. Both are exceedingly sensitive to the effects of denaturing agents. Even salts, such as CaCl_2 or LiCl , at low concentrations rapidly destroy the streaming double refraction of myosin (9).

Astbury (3) has presented evidence to show that myosin in relaxed muscle is in the α state; on muscular contraction, he claims it becomes "supercontracted." It is certain, in any case, that the insolubility accompanying muscular contraction is not identical with the denaturation of a corpuscular protein, for no alteration in the number of sulfhydryl groups takes place (25). On treating myo-

sin with acid or heat, the SH groups alter in number (25), and Astbury believes the extended β form is then produced. If so, it is strange that the effect of these agents is to remove the streaming double refraction (9).

Likewise, when the sea urchin egg was fertilized, Mirsky found no change in SH groups accompanying the decrease in protein solubility (24). These groups appeared, however, if the egg was treated with acid. Of all the ways of coagulating myosin *in vitro*, Mirsky finds that only dehydration produces no change in SH groups. Dehydration readily renders the isolated egg protein insoluble. He suggests, therefore, that both muscular contraction and fertilization act as dehydrating agents which permit the protein molecules to come close enough together to combine with each other and become insoluble without much intramolecular disturbance.

Banga and Szent-Györgyi (4) have recently proposed that,

“Whenever nature needs a mobile protein (serum albumin and globulin, secretions like milk-proteins, hormones like insulin, different enzymes, etc.) it applies the globular shape, and whenever it wants to build a solid structure it applies the rod shape. Proteins have been found to be mostly globular because unconsciously the mobile and more easily accessible proteins have been selected for study.”

These authors have succeeded in dispersing some of the structural proteins from tissues like kidney and from chloroplasts and find the extracts to be highly viscous and thixotropic and to exhibit streaming double refraction. They believe this last property indicates that these structural proteins belong to the fibrous group. Banga and Szent-Györgyi used salt solutions containing 30 per cent urea to disperse these proteins, a substance capable of inducing marked changes in the structure of other proteins. Whether or not these dispersed tissue proteins have the same constitution as the native forms is questionable. They seem to be different from the corpuscular proteins, for these do not exhibit streaming double refraction after treatment with the salt-urea solution. This work is an interesting beginning in a difficult, but important, field.

It is obvious that myosin and Mirsky's egg proteins are very different in their properties from the corpuscular proteins. The evidence indicates, furthermore, that they exhibit important differences from the truly fibrous proteins, in spite of the findings of Banga and Szent-Györgyi. Unlike the fibers, these intraprotoplasmic proteins are characterized by an extreme sensitivity to heat or to electrolytes. It is possible that they are extended to a fibrous condition

by denaturation. Indeed this may be the case with the proteins investigated by Banga and Szent-Györgyi. Perhaps these intraprotoplasmic structural proteins should be classified as a separate group.

At all events, it appears evident that many of the physical properties of protoplasm can be ascribed to its proteins and that these provide a labile, structural framework within which metabolism can take place. It has been suggested that the cell is a "protein crystal." Although varying portions of the cell may exhibit transitory birefringence, the notion of a whole cell as a crystal seems too static. To use the words of Frey-Wyssling (13), "Das Haftpunktsystem der lebenden Substanz ist daher nicht etwas Gegebenes, wie z. B. bei Gelatine- oder gar bei Zellulosegelelen, sondern beständig ist bei ihm nur der Wechsel!"

FOOTNOTES

¹For a discussion of theoretical aspects of polarization microscopy, see Ambronn and Frey (2), Schmidt (41), and Schmitt (42).

²It is suggestive that Coult (8) has found that germination of seeds is accelerated by shaking them. Shaken seedlings showed a significantly greater increase in weight (wet and dry) over controls.

³The results of Beams and King (5) are interesting in this connection. They found that fertilized *Ascaris* eggs retained their capacity to cleave, even after long centrifugation at 100,000 to 400,000 times gravity. Some eggs divided in the centrifuge. These centrifugal forces are more than enough to sediment small corpuscular proteins. Beams and King conclude that Svedberg's stratification does not take place and that either there is no need for definite spatial relationships or else the protoplasm does not behave as a free dispersion of protein particles. The latter hypothesis seems more likely in the light of Mirsky's evidence for a structural framework after fertilization.

⁴Since the preparation of this chapter, Dr. Mirsky has brought the interesting work of Bensley to my attention (Bensley, R. R., and Hoerr, N. L., *Anat. Rec.* 60: 251-266. 1934; Bensley, R. R., *Anat. Rec.* 72: 351-369. 1938). Bensley has isolated structural proteins from the cytoplasm of liver cells in what appears to be an undenatured state. The original articles should be consulted for further details.

BIBLIOGRAPHY

1. ABRAMSON, H. A., GORIN, M. H., AND MOYER, L. S. The polar groups of protein and amino acid surfaces in liquids. *Chem. Rev.* 24: 345-366. 1939.
2. AMBRONN, H., AND FREY, A. *Das Polarisationsmikroskop.* Leipzig. 1926.
3. ASTBURY, W. T. X-ray studies of the structures of compounds of biological interest. *Ann. Rev. Biochem.* 8: 113-132. 1939.
4. BANGA, I., AND SZENT-GYÖRGYI, A. Structure-Proteins. *Science* 92: 514-515. 1940.
5. BEAMS, A. W., AND KING, R. L. Survival of *Ascaris* eggs after centrifuging. *Science* 84: 138. 1936.
6. BULL, H. B. Protein denaturation. *Cold Spring Harbor Symposia on Quantitative Biology* 6: 141-149. 1938.
7. CHAMBERS, R. The physical structure of protoplasm as determined by microdissection and injection. In Cowdry, E. V. *General Cytology*, pp. 237-309. 1924.

8. COULT, D. F. Some observations on the effect of shaking on plants with particular reference to *Sinapis alba* L. *Protoplasma* 32:92-115. 1939.
9. EDSALL, J. T., AND MEHL, J. W. The effect of denaturing agents on myosin. II. Viscosity and double refraction of flow. *Jour. Biol. Chem.* 133:409-430. 1940.
10. ENGELMANN, TH. W. Contractilität und Doppelbrechung. *Pflügers Arch. ges. Physiol.* 11:432-464. 1875.
11. FREUNDLICH, H., AND ABRAMSON, H. A. Über die Thixotropie von Gelatine-lösungen. *Zschr. physik. Chem.* 131:278-284. 1927.
12. ——— AND SEIFRIZ, W. Über die Elastizität von Solen und Gelen. *Zschr. physik. Chem.* 104:233-261. 1933.
13. FREY-WYSSLING, A. Submikroskopische Morphologie des Protoplasmas and seiner Derivate. Berlin. 1938.
14. GERNGROSS, O., HERRMANN, K., AND ABITZ, W. Über den Feinbau des Gelatinemicells. *Biochem. Zschr.* 228:409-425. 1930.
15. HARVEY, E. B. Parthenogenetic merogony or cleavage without nuclei in *Arbacia punctulata*. *Biol. Bul.* 71:101-121. 1936.
16. HIRSCH, G. C. Form und Stoffwechsel der Golgi-Körper. Berlin. 1939.
17. KERR, T. The injection of certain salts into the protoplasm and vacuoles of the root hairs of *Limnobia spongia*. *Protoplasma* 18:420-440. 1933.
18. MARK, H. The elasticity of long chain compounds as a statistical effect. *Chem. Rev.* 23:121-135. 1939.
19. MARSLAND, D. A. The mechanism of protoplasmic streaming. The effects of high hydrostatic pressure upon cyclosis in *Elodea canadensis*. *Jour. Cell. Compar. Physiol.* 13:23-30. 1939.
20. MEHL, J. W., ONCLEY, J. L., AND SIMHA, R. Viscosity and the shape of protein molecules. *Science* 92:132-133. 1940.
21. MEYER, K. H. The state of aggregation of rubber and of substances with rubber-like extensibility. *Chem. Rev.* 25:137-149. 1939.
22. ——— AND JEANNERAT, J. Les propriétés des polymères en solution. XI. Sur la formation du fil de soie à partir du continu liquide de la glande. *Helv. Chim. Acta* 22:22-30. 1939.
23. ——— AND PICKEN, L. E. R. The thermoelastic properties of muscle and their molecular interpretation. *Proc. Roy. Soc. London B* 124:29-56. 1937.
24. MIRSKY, A. E. Protein coagulation as a result of fertilization. *Science* 84:333-334. 1936.
25. ———. Protein denaturation. *Cold Spring Harbor Symposia in Quantitative Biology* 6:150-163. 1938.
26. ——— AND PAULING, L. On the structure of native, denatured, and coagulated proteins. *Proc. Nat. Acad. Sci. U. S.* 22:439-447. 1936.
27. MOHL, H. VON. Über die Saftbewegung im Inneren der Zellen. *Bot. Ztg.* 4:73-78, 89-94. 1846.
28. MOORE, A. R. On the significance of cytoplasmic structure in plasmodium. *Jour. Cell. Compar. Physiol.* 7:113-129. 1935.
29. ——— AND MILLER, W. A. Occurrence of birefringence in the fertilized egg of the sea urchin. *Proc. Soc. Exp. Biol. Med.* 36:835-836. 1937.
30. MOYER, L. S. Electrokinetic aspects of protein chemistry. *Cold Spring Harbor Symposia on Quantitative Biology* 6:228-243. 1938.
31. MUDD, E. B. H., AND MUDD, S. The process of phagocytosis. The agreement between direct observation and deductions from theory. *Jour. Gen. Physiol.* 16:625-636. 1933.
32. NEURATH, H. The diffusion of proteins. *Cold Spring Harbor Symposia on Quantitative Biology* 6:196-207. 1938.
33. NORTHEN, H. T. Studies of protoplasmic structure in *Spirogyra*. I. Elasticity. *Protoplasma* 31:1-8. 1938.

34. ——— AND NORTHEN, R. T. Studies of protoplasmic structure in *Spirogyra*. II. Alterations of protoplasmic elasticity. *Protoplasma* 31:9-19. 1938.
35. PAULING, L. The nature of the chemical bond. Second ed. Ithaca and London. 1940.
36. PFEIFFER, H. Further tests of the elasticity of protoplasm. *Physics* 7:302-305. 1936.
37. PICKEN, L. E. R. The fine structure of biological systems. *Biol. Rev.* 15:133-167. 1940.
38. PLOWE, J. A. Membranes in the plant cell. II. Localization of differential permeability in the plant protoplast. *Protoplasma* 12:221-240. 1931.
39. RINNE, F. Schwächung des feinbaulichen Zusammenhanges durch Wasser und wässrige Lösungen. *Koll. Zschr.* 61:304-308. 1932.
40. SCARTH, G. W. The structural organization of plant protoplasm in the light of micurgy. *Protoplasma* 2:189-205. 1927.
41. SCHMIDT, W. J. Die Doppelbrechung von Karyoplasma, Zytoplasma und Metoplasma. Berlin. 1937.
42. SCHMITT, F. O. The ultrastructure of protoplasmic constituents. *Physiol. Rev.* 19:270-302. 1939.
43. SEIFRIZ, W. An elastic value of protoplasm, with further observations on the viscosity of protoplasm. *Brit. Jour. Exper. Biol.* 2:1-11. 1924.
44. ——— Protoplasm. New York. 1936.
45. ——— AND PLOWE, J. Q. Effects of salts on the extensibility of protoplasm. *Jour. Rheology* 2:263-270. 1931.
46. STAUDINGER, H. The formation of high polymers of unsaturated substances. *Trans. Faraday Soc.* 32:97-115. 1936.
47. ULLRICH, H. Einige Beobachtungen über Doppelbrechung am lebenden Protoplasten, an verschiedenen Zellorganellen sowie der Zellwand. *Planta* 26:311-318. 1937.

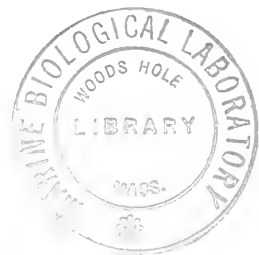

MOLECULAR STRUCTURE IN PROTOPLASM

O. L. SPONSLEER AND JEAN D. BATH

*Laboratories of Physical-Biological Sciences, University of California,
Los Angeles*

The principal aim in the sciences is comprehension; often a secondary aim is control; and the more fundamental the nature of the comprehension, the more certain is prediction and control. With ideas somewhat like these in mind about ten years ago, we began to turn from the molecular structure of cellulose (1) to the possibilities of molecular structure in the components of protoplasm, with the intention of carrying the molecular viewpoint as far as we were able up into the submicroscopic or colloidal range and further, if possible, into the microscopic.

With the realization that many vital activities, although not all of them, may occur at the molecular level, we felt that attempts which would elucidate molecular structure and spatial arrangements would be worthwhile even though the results obtained were far from either conclusive or complete. The structural goal towards which we are striving is still very indistinct although the stepping stones are surprisingly clear and well defined in many cases. It is like climbing toward the top of a high mountain; we carefully pick our steps that we may not stumble; we make false starts, often finding the way blocked by a wall or a chasm, but consistently the way leads upward, always intriguing, and keeping us wondering what remarkable vista awaits at the top.

The comprehension we desire is of protoplasm on a molecular level, in the range of molecular dimensions. To attain this, familiarity is necessary with atoms considered as small particles; with groups containing a few atoms, small molecules; with large molecules containing the principal features of many small molecules; with small submicroscopic particles, and with large particles close to the range of visibility. In all cases we think of them as endowed with definite properties of weight and of spatial dimensions, such as shape and size. In addition to these they have other properties which may be described in a general way as attraction and repulsion. These categories are somewhat clearer when we say that the molecules

of the organic substances, sugar, fats, and allied compounds, are "small molecules"; the proteins are to be thought of as "large molecules"; while aggregates of an indefinite, although a small number, of protein and other molecules, are considered as "small submicroscopic" particles. The "large particle" may be composed of many hundreds or thousands of these three. It is obvious that the four size classes are merely arbitrary conveniences, although they may have vague boundary lines.

The small molecules are, in size, about 5 to 10Å; the large molecules, about 20 to 50Å; while the small particles range from 50 to 100Å or larger; and the large particles, from say 500Å to 5,000Å. Particles of 5,000Å, or 0.5 micron, in diameter are at the limit of microscopic visibility. Each of these size classes may be thought of as furnishing structural units, or members, for particles of the next larger class. A particle at the limit of visibility could conceivably consist of approximately a million small 50Å particles. This conception of multiple aggregates leads to the necessity for thinking in terms of dimensional levels, since it is practically impossible to visualize the details of one of the component molecules and at the same time to visualize the whole structure containing a million of these and to recognize the internal organization and many complex details of structure which undoubtedly exist.

The particulate nature of cytoplasm is well known from microscopic and ultramicroscopic observations (2, 3, 4, 5, 6), which have recognized the existence of particles ranging in size from the visible far down into submicroscopic regions. Properties of these particles are, however, very inadequately known. It seems reasonable to think that properties, such as weight, shape, size, electrical features, and other characteristics, must derive from their molecular composition, and that their capacity to take part in metabolic activities of any sort is a consequence of these properties. Considerable evidence from chemical and physical investigation (7, 8, 9) has accumulated concerning the molecular components, especially the protein molecule, which should be useful in attaining a comprehension of the nature of these particles and their properties. A particle composed of a thousand or more 50 Å protein particles may be readily conceived as having considerable internal organization and many complex details of structure, which give it catalytic properties and make of it a functional aggregate.

By the term, functional aggregate, we mean that the relative arrangement of the constituents is such that certain reactions can

occur which could not take place if these positions in space were altered. In other words, the usefulness to the protoplasm of one large molecule may be dependent upon the arrangement of a dozen or more molecules immediately adjacent to it in the particle. Organization comparable to this on a visible level may be observed in the orderly behavior of chromosomes at mitosis; but organization on a molecular level is not so obvious, although rather specific arrangements of molecular structures seem to be essential in the synthesis of glucose, and definite arrangements of enzymes are involved in respiration.

To comprehend organization of molecules within particles of visible size, and even of particles below visibility, seems at first glance to be quite impossible because the number of component molecules is so great. Fortunately, however, these molecules possess many features in common, and many individuals of one type may occur; as a result of this the particle as a whole, consisting of a thousand such molecules, may appear in some aspects as a structural repetition pattern. Comprehension of one of these structural units is a long step toward the comprehension of the whole.

We have just mentioned the possibility of a definite structural interrelation between a dozen or more molecules within a single particle as necessary for a particular activity. A molecular group of this sort may be considered as a mechanism when by virtue of its spatial configuration it is enabled to carry on a particular set of activities, to serve a specific purpose in the cell. It is conceivable that small mechanisms may become aggregated into still larger composite particles. Thus several individual, molecular mechanisms may become component parts of a single larger, more complex machine. It is further conceivable that these micellar mechanisms may in turn become aggregated into much larger submicroscopic particles and that each of these may become a mechanism of great complexity adapted to a still different sort of activity. In each case the component building blocks, whether molecules or small aggregates, lose their obvious individual identity when they become attached into a larger particle.

Why then stop at a particular size? Why, indeed? A microscopically visible plastid is most certainly a mechanism since it may function in building starch grains. It is a mechanism on a visible dimensional level and may be thought of as built of millions of smaller particles, but the individuality of these particles has become lost in the formation of the larger structure. Or on a still higher

level, the whole cell at mitosis becomes a single mechanism, ephemeral, yes, but a mechanism nevertheless, for a specific purpose, and for a short time the particles of the cell may be considered also as having lost their identity.

We must interpolate here, before taking up any of the specific molecular characteristics, two points of view which are constantly creeping into our ways of thinking of protoplasm; one is analytic in nature; the other, synthetic. These terms are rather loosely descriptive, but differences will appear as we proceed.

To understand a mechanism in protoplasm, we must first recognize that it is a mechanism; and when we have broken it down to its components, we must also, by some experimental means, recognize the components as such. Thus we may step from the level of a living structural mechanism, which we have recognized by physiological experimentation, down to the level of the components, which we study by physical-chemical methods. We assume that the physiological processes by which we recognized the mechanism have their origin in the physical or chemical characteristics of some portions of the component pieces into which the mechanism has been broken. In this analytic method we seek these active portions and are likely to disregard the original framework. Opposed to this analytic procedure the synthetic method starts with atoms and molecules as building stones for the construction of larger particles and mechanisms. Each step up is possible only because the characteristic properties of the small structural building stones make specific spatial arrangements possible. This building-up process presupposes a knowledge of certain properties of the components which will allow them to take up specific positions with respect to one another, and as a result of their relative positions, willy nilly, to form mechanisms essential to the activity of the cell. The analytic method starts with a rather vague mechanism, known principally by its performances, and attempts to comprehend the machine by breaking it down and observing the behavior of the pieces which in turn are not too well comprehended. In contrast to this the synthetic method dwells more on the structure of the fairly well known components but understands the behavior less when the components are assembled. Obviously both methods are essential to a reasonably clear understanding of vital activities, but it is the latter method which is of especial interest to us here. Of course, in any study, these two procedures are often used interchangeably, and along

with their argument by analogy creeps in perhaps a little too frequently, and often in a rather far-fetched manner.

In this discussion, then, we are attempting to form a conception of a type mechanism as viewed on a molecular level. For this purpose we have chosen the only one for which there seems to be enough information available to give us at least a tentative conception. This is associated with respiration, and while the conception of the mechanisms involved is still in a very hypothetical stage, an attempt at the comprehension of them may nevertheless serve as an avenue of approach to an understanding of the mechanisms on still higher levels.

Investigations into the reactions and the materials necessary for the processes or activities which we think of collectively as respiration have given a fair idea of the various steps involved and of the molecules required (10, 11). Each step, it is thought, requires a protein molecule with an attached small molecule; the two together are considered as an enzyme. Many such enzymes are required for the complete breakdown of a glucose molecule (10, 11) and there is evidence (12, 13) that several of these may occur combined within a single complex. That these enzyme systems are arranged in an organized manner seems evident from the observations (14) that certain activities are lost when the complex is disintegrated, and that these enzyme systems are not rebuilt upon standing although apparently all of the constituents are present.

The frequency of occurrence of these respiration complexes locally in the protoplasm is not known, but that many thousand such mechanisms are distributed throughout the cell seems not too unreasonable. In the active cell they occur in a water medium in which molecules and ions of various kinds are also present, and since these may be expected to influence the complex, it may be well to first obtain a general picture of the cell as a whole on a molecular level.

MOLECULAR CONSTITUENTS OF PROTOPLASM

From analyses of the protoplasms of many organisms the components of active cells may be listed in a general manner as in Table 1.

The proportions shown in Table 1 may be thought of as minima of a sort but essential, nevertheless, for active protoplasm. By using average molecular weights for the various constituents, a rough estimate of the relative number of each may be obtained, as shown in Table 2.

TABLE 1
GENERALIZED PROTOPLASMIC ANALYSIS

Substance	Percentage of fresh weight
Water	85-90
Proteins	7-10
Fatty substances	1- 2
Other organic molecules	1- 1.5
Inorganic ions	1- 1.5

TABLE 2
RELATIVE NUMBER OF MOLECULES OF THE VARIOUS TYPES OF PROTOPLASMIC MATERIALS

Substance	Percentage Used	Average Molecular Weight Used	Approximate Relative Number of Molecules
Protein	10	36,000	1
Water	85	18	18,000
Fatty substances	2	700	10
Other organic substances	1.5	250	20
Inorganic material ...	1.5	55	100

These numerical proportions help us to grasp the cytoplasmic picture somewhat better since we may now think of one large protein molecule surrounded by about 20,000 minute water molecules in which the remaining relatively small molecules occur.

To make this still more vivid, dimensions of these molecules and their shapes are needed. These may be obtained by recourse to two fields: to the chemical, which furnishes the structural formula and the interrelationships of the atomic components; and to the physical, which supplies the size and valence angles of the respective atoms. From this information it is possible to determine the dimensions of the molecules and also to obtain a great deal of information concerning their spatial relations and other properties of their constituent atomic groups (21). Space limits us at this time to brief descriptive notes of only the most prominent spatial characteristics of these molecular structures.

STRUCTURAL FEATURES OF COMPONENT MOLECULES

Of the component molecules in protoplasm, water is the smallest and apparently the simplest in structure. It has, however, charac-

teristics peculiar to itself which detract somewhat from its simplicity. for, while each water molecule consists of one oxygen and two hydrogen atoms, the atomic nuclei and constituent electrons are so arranged that two residual negative electrical fields and two positive fields occur at tetrahedral points in the molecule (15). These are effective in making the water molecule a permanent dipole (16). The more prominent features are indicated in the diagrams of Figure 1 and are mentioned because these characteristics are constantly involved in the structure and behavior of protoplasm as well as in the aggregation of the water molecules themselves (17). The radius of the spherical structure shown in Figure 1.A, with two great circles at right angles to each other, is about 1.38 Å. At B the effect of the intermolecular plus-minus attractions is shown as in ice where four surrounding water molecules are coordinated tetrahedrally with a central molecule (15, 18). Such groups vary in amount with the temperature; and in themselves vary in number from one and two at the boiling point to a group of several or many near freezing (17).

When a portion of the water molecule occurs as a hydroxyl group, —OH, on an organic molecule, one of the plus residual points is missing due to the formation of the primary valence bond; this leaves only three points for coordination with water molecules in the surrounding solution. It is due to the nature of the oxygen atom (19) that these negative residuals occur. Only one other atom, which is of interest to us, is similar in this respect; this is nitrogen (19), which has, however, only one negative residual charge. Thus, what is said of oxygen and OH groups will apply to a considerable extent also to NH and NH₂ groups. Residuals of this nature are completely lacking in the carbon atom and in CH₂ groups.

There seems to be scarcely any need of mentioning here that the four atoms, C, H, O, and N, are the principal components of protoplasmic molecules and that they make up nearly 99 per cent of active protoplasm. One feature of these atoms which is less commonly known, although characteristic of the three larger atoms, C, O, and N, was shown in Figure 1. This is the angle at which bond formation occurs. This angle made by adjacent primary valence bonds is practically 109° and is spoken of as a tetrahedral angle (19). Its occurrence will be noted in figures of the models presented here wherever single primary bonds exist. The angle is relatively rigid and therefore determines the shapes of molecules to a great extent, as may be seen later in the models mentioned where the four bonds of carbon reach out to form a tetrahedral structure; simi-

larly for the three of nitrogen and its single negative residual; and also the two bonds of oxygen with its two negative residuals. When a double bond occurs between atoms, this bond (19) makes an angle of approximately 125° with the other single bonds present. It must not be overlooked, however, that rotation on primary valence bonds

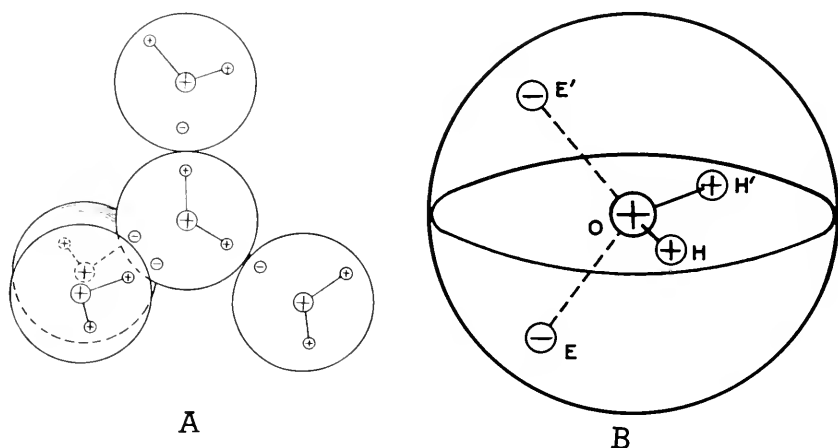

FIG. 1. A. Diagram to show tetrahedral distribution of the two hydrogen nuclei and two negative residuals in a water molecule. The distance between the oxygen and hydrogen nucleus is approximately 0.96 \AA , and the two hydrogen nuclei make an angle of about 105° with the oxygen nucleus (15). B. Diagram showing coordination of several water molecules around a central one resulting from the attraction of the negative residual of one molecule for the hydrogen nucleus, or proton, of another (15).

may occur (19) so the shapes indicated may vary somewhat from the model photographs shown.

The radii of the various atoms are included in Table 3. An additive law is effective for these; thus when two atoms, such as

TABLE 3
ATOMIC RADII (19)

Atom	Radius for Single Bond	Radius for Double Bond
Carbon	0.77 \AA	0.69 \AA
Nitrogen	0.70	0.63
Oxygen	0.66	0.59
Hydrogen	0.29

carbon and oxygen, are joined by a single bond as in Figure 2, the distance between their atomic centers is the sum of their single bond radii, i. e., $0.77 + 0.66 = 1.43$ Å.

It thus appears that protoplasmic molecular structures have a certain basic similarity regardless of the kind of atoms involved.

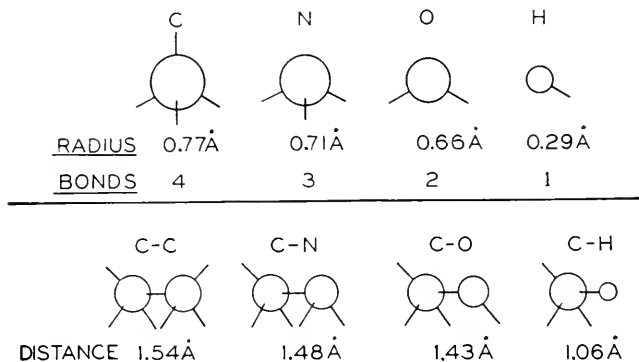

FIG. 2. Diagrams showing spatial properties of carbon, oxygen, nitrogen, and hydrogen atoms. Lower portion shows interatomic distance between two atoms joined by a single bond.

since the values of the angles and of the radii are practically the same in all. Structural and cohesive differences arise, however, due to the residual negative charge on the oxygen and nitrogen atoms and to the absence of these residuals on the carbon atom. These residual forces, it will be seen later, are responsible for the formation of the hydrogen bond (19, 20), a mechanism of considerable importance in the cohesion of molecules. In this mechanism the proton, or hydrogen nucleus, of an $-OH$ or $-NH_2$ group is pulled toward the negative residual of another oxygen or nitrogen atom. This attraction results in a closer approach (2.8 Å) of the two groups than would otherwise occur (3.5–4.0 Å). The hydrogen proton, as shown in Figure 3, is always involved, and for this reason the bond is spoken of as the hydrogen bridge.

The component of protoplasm which is universally recognized (21, 22, 23, 24, 25) as being of most importance structurally is protein. Various investigators using microchemical methods have demonstrated its existence in cytoplasmic particles (26, 27, 28, 29, 30); and many other workers (31 and 64) have demonstrated the importance of the proteins in respiratory mechanisms. At this point

the dimensional properties are of chief interest to us. It has become well known that although many different kinds of proteins are recognized they are all built on practically the same structural scheme. Since the amino acids are all of the alpha form, they link together to form a long peptide chain in which the adjacent amino acid residues alternate from one side of the molecule to another. The model in Figure 4 represents only a small portion of such a

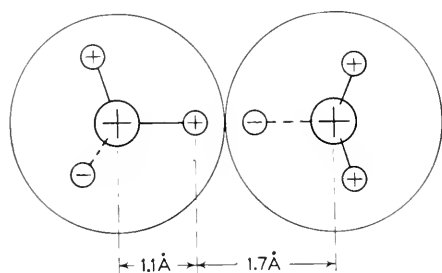

FIG. 3. Diagram of hydrogen bridge between two water molecules. Note attraction of residual negative charge on one, for hydrogen nucleus, or proton, on the other, and the separation distance of 2.8Å.

chain but nevertheless shows its characteristic features; that is, the central zig-zag backbone portion and the various side chains, or amino acid residues, which extend out at right angles to it. The backbone feature is the feature which is common to all proteins, while the kind and arrangement of the amino acid residues give the protein its specific qualities.

The dimensions of this basic, structural chain are nearly the same for all of the proteins (32, 33). Along the backbone each amino acid residue is allotted about 3.5 Å or slightly less. As a result of this, the length of the chain depends directly upon the total number of residues. Thus, a chain of 300 residues is likely to be about 1,000 Å long. The width varies somewhat depending upon the size and the proportional content of the various residues. The shortest residue, glycine, extends scarcely an Angstrom from the backbone; while the longest, arginine, or perhaps tryptophane, may extend 6 to 8 Å. The width of the chain as a whole, then, depends upon the weighted average for the 300 or so constituent residues of various lengths, and while it is slightly different from protein to protein, depending upon the percentages of the various short and long residues (32), the width is, despite this, fairly consistently close to 10 Å, rarely more than 12 Å, and seldom less than 9 Å. The thickness of the chain through the backbone and normal to the 10 Å width is consistently 4.5 Å for all of the many proteins which have been measured (32). A few are 4.4 Å, and an occasional one is 4.6 Å. From these values a generalized conception is obtained of the chain dimensions, $4.5 \text{ Å} \times 10 \text{ Å} \times (3.5)^n$, where n is the number

of amino acid residues. Thus a protein of molecular weight 36,000 with about 300 amino acid residues of average molecular weight, 120, will have a chain length of about 1,000 Å, a width of about 10 Å, and a thickness of 4.5 Å.

Although these generalized chain dimensions are well enough established, the configurations which the chains may take and the resulting sizes, shapes, and structural details in the formation of

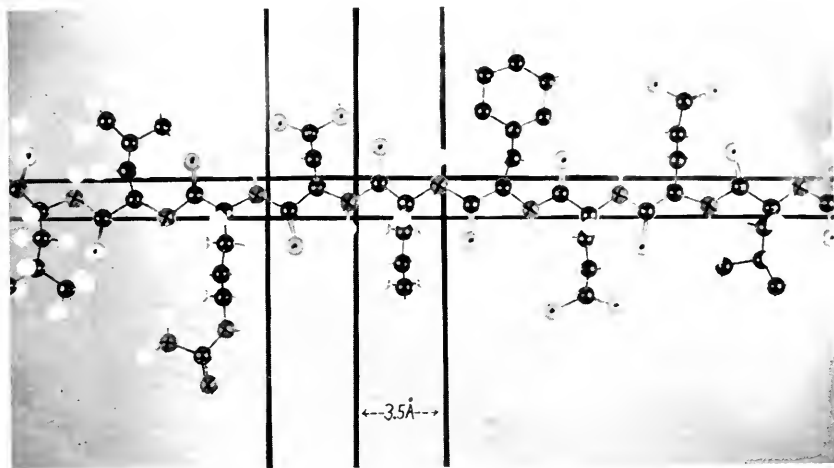

FIG. 4. Model photograph of a portion of a protein chain, made to scale using known atomic radii and bond angles. Black balls indicate carbon atoms; dark grey balls marked X indicate nitrogen atoms; light grey balls marked with a dot indicate oxygens; small white balls, hydrogen atoms.

submicroscopic particles is less satisfactorily known. Practically all of our knowledge concerning these comes from investigations of proteins in bulk which have been treated in various ways for purposes of purification. Material of this sort has been subjected to many experimental procedures in attempts to determine the existence of elementary protein particles, or molecules, and their sizes, shapes, and structural details.

Investigations as to size or sizes of the elementary particles have been made by means of osmotic pressure and diffusion measurements (34, 35), analytical methods (37), the ultracentrifuge (9, 38), and determination of the unit cell dimensions in crystalline proteins (36 and 39). From this work it appears that the protein particles may belong to groups of molecular weight 17,500, or some multiple of this value, as 35,000 or greater; or submultiple, as 9,000.

Concerning the shape, a number of different experimental methods show that many elementary protein molecules are globular in outline rather than elongated as a completely extended chain, although globular in this instance may mean anything from spherical to considerable elongation. These methods include studies of viscosity—concentration curves (40), comparison of ultramicroscopic observations (41), determination of asymmetry by means of the ultracentrifuge (9), unit cell determinations of crystalline proteins by means of X-ray analysis (36 and 39), comparisons of double refraction of flow (42), and rotation in an electric field (43). Certain proteins, such as silk and gelatin apparently have their chains fully extended for considerable lengths; others form particles having various length-thickness ratios (44); and a few are practically isodiametric. A single chain of 1,000 Å in length is about 100 times as long as it is thick. Zein forms particles which are about 20 times as long as their width; erythrocrucorin, about 10 times; and insulin, about 2 or 3 times; while for egg albumen the particles are nearly isodiametric (44). One of the most significant points, in addition to the globular nature of many protein molecules, is that proteins belonging to the same weight class may differ enormously in shape (44).

Regardless of shape or size the particles seem to consist of polypeptide chains folded in some manner to give the respective shape. Very little is known concerning the exact configuration which the chain takes, but it seems probable that it is a function of the nature and distribution of its side chains (45) and of its environment at the time of synthesis (46). Whatever model is accepted, the general configuration of the protein chain in the globular particle must be consistent with the observations that reflections from parallel packets of protein chains may be obtained fairly easily from the protoplasmic material upon the removal of water (33, 47, 48). A working model has been proposed (46, 49, 50, 51) for the configuration of the chain in the globular particle. The essential feature of this hypothetical configuration is that the peptide chain occurs in parallel folds forming a monolayer in which the residues extend out approximately perpendicular to the surface, thus making the layer about 10 Å in thickness. Packets containing about 1,400 of such monolayers, piled one upon another, have been prepared, and the individual monolayer thickness of 10 Å has been found by direct micrometer measurement (50 and 52). These monolayers may either attach to one another to form a layered globular particle, or

an individual monolayer may become folded to form a three-dimensional particle. Such particles are probably held together by cystine bridges, ionic linkages, or hydrogen bridges. The specific configuration within the globular particle might be quite irregular and depend upon the distribution of cysteine and ionizable residues and on the placement of proline and short residues which make folding possible, although the general plan might be similar to this hypothetical model.

The features of the protein particle, size, shape, and configuration of chain, just given, were taken from the results of work on proteins *in vitro*. So far as the elementary particles in protoplasm are concerned, reasoning by analogy, we may expect to find protein particles of several shapes on this level where 1,000 Å lengths or smaller are under consideration; that is, as extended chains, as cylindrical or globular structures, and possibly even as flattened discs.

A clean-cut parallelism of the chains as indicated for the monolayer has not been demonstrated for the particles in protoplasm, although a certain degree of parallel arrangement is indicated by X-ray (33) and polarized light investigations (53). For convenience in discussion we are assuming a model which has a greater degree of parallel placement of the chains than is justified by experiment, feeling that the convenience outweighs the chances of serious misinterpretation. Also for convenience we are making use of a cubical shape for the elementary protein particle as one which may be more easily treated.

A chain of approximately 1,000 Å in length, folded into a globular particle in the manner indicated above, may consist, for example, of 20 folds, each about 50 Å in length, arranged into three layers of about seven in a row, as in Figure 5, making a packet 30 x 30 x 50 Å of solid protein. The same chain length would make a block of 10 folds 100 Å long but would be only about 25 Å thick; that is, about one-fourth its length. If, however, the particle consisted of only four pieces of 250 Å, its thickness would be about 15 Å, or its length would be nearly 20 times as great as its thickness. These are comparable to the particle shapes mentioned as obtained experimentally with proteins *in vitro*.

Particles such as these in protoplasm would no doubt take on water molecules through hydrogen bridge formation wherever oxygen- and nitrogen-containing groups were spatially available, as at the ends of polar residues and along the backbone (54). In a hydrated particle where 40 per cent water or more is included, there

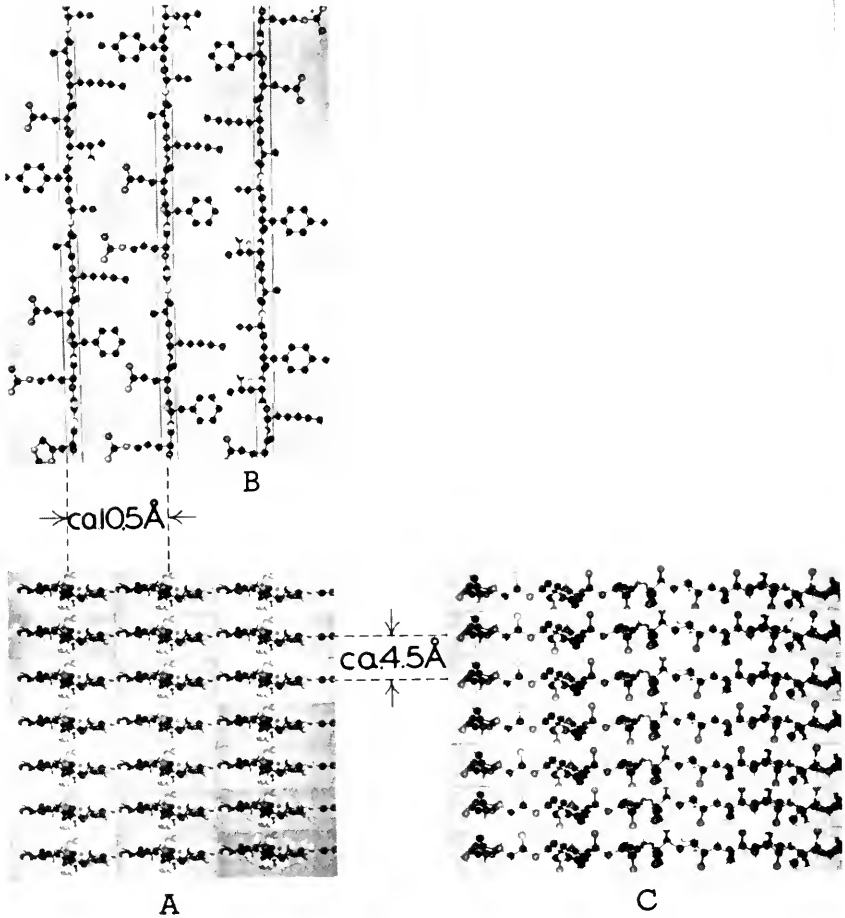

FIG. 5. Model photographs showing three faces of a packet of parallel protein chains. A. Three rows of seven chains each showing ends of the chains. Note flat shape of individual units when viewed in this direction; width approximately 10.5 Å, thickness about 4.5 Å. B. Top view of same packet. C. Side view.

is a strong probability that water molecules, by means of hydrogen bridges, may form a seam between adjacent backbones (54). The spacing may then become about 7 Å instead of 4.5 Å as when dry. The hydrophilic end groups may furnish loci for hydrogen bridges between the layers within a particle and also between particles. Here the distribution of the oxygen- and nitrogen-bearing residues is effective in furnishing few or many bridges according to the

patterns formed by these residues on the surface. The presence of the water molecules within the particle may spread the chains laterally from the 10.5 Å distance when dry to perhaps as much as 15 to 20 Å when water is plentiful as in an active cell. This would enlarge the protein packet just mentioned to a cube of about 50 Å on an edge.

Although the particles may appear regular in diagram, they will no doubt be definitely irregular in outline due to the variable lengths of the amino acid residues and perhaps to the uneven length of the chain folds. Details of the structural features will depend to a considerable extent upon the proportion and distribution of the residues on the chain, as well as upon the number of chain folds in the particle.

We turn now to a more intimate consideration of the residues and their influence upon the formation of these larger structures. There are about twenty different amino acids obtainable from practically every protein, and one protein differs from another in the proportion of the amino acid residues it contains. Thus while gelatin contains 25.5 per cent glycine (55), casein has only 0.5 per cent (56) and so for the variations in quantity of all twenty. While the amino acids themselves have a generic similarity, in that each has a group consisting of a carboxyl and an amino group attached to the alpha carbon, they differ specifically in the remainder of the molecule (57). In general, in the case of cytoplasmic proteins, at least one-third of the total residues are polar; the remaining two-thirds have residues which contain neither oxygen nor nitrogen atoms and thus are comparable to fatty substances in their behavior toward water. In contrast to this about one-third of the amino acid residues have either OH or COOH as oxygen-containing groups, and NH₂ or some other nitrogen-containing group such as the guanidine group or the imidazole ring. Those having an affinity for water coordinate with various, but rather specific, numbers of water molecules; for example, OH and NH₂ may each form hydrogen bridges with three water molecules (54).

In the formation of larger protein structures, ionization plays an important part. From the amino acid analyses (8) of various proteins whose residues are approximately one-third polar, it is possible to ascertain that approximately 85 per cent of these polar residues are ionizable at pH 7, the pH of cytoplasm; that is, about one-fourth of the total residues on the chain or at least 60 out of

300 residues are capable of existing ionized at this concentration of hydrogen ions.

The manner in which the end groups of the various amino acid residues become ionized is indicated for the two general types.

A. *The acidic groups* lose a proton and thus bear a negative charge. They include glutamic and aspartic acid residues.



B. *The basic groups* gain a proton and thus carry a positive charge. Three types are of importance.

1. The amino group of lysine.



2. The guanidine group of arginine (19).

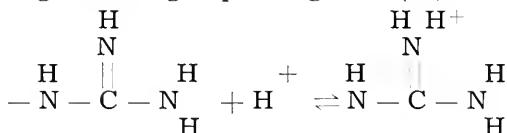

3. The imidazole ring of histidine (59).

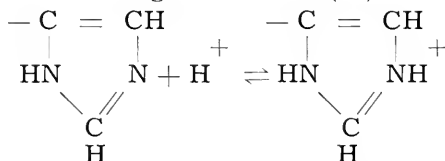

Studies (58) correlating the range of hydrogen-ion concentration in which these groups ionize (7) with the resultant hydrogen-ion concentration of cytoplasm (23, 60, 61, 62), indicate that glutamic and aspartic acid, as well as arginine and lysine, are probably completely ionized at the pH of cytoplasm. Histidine may be expected to be only partially ionized, and tyrosine, serine, and the amide groups of asparagine and glutamine probably not at all (7). The relative number of positively and negatively ionized residues, as well as their spatial distribution (63), may be expected to have a great influence upon the electrical field surrounding the elementary protein particles. Some of these ionized groups will be distributed throughout the interior of the particle, perhaps forming ionic linkages which may help to maintain the specific configuration of the chain (46 and 51); other ionized groups may exist on the surface of the particle. A particle, such as in Figure 5, consisting of three layers, will have six faces over which charged groups may be distributed, and these should have at least six to eight ionized groups on each face; some plus, some minus. In the model at least four of

the six surfaces would contain ionized residues available for the attachment of small organic molecules.

The interaction of one charged particle with another in its immediate environment depends largely upon the pattern of the electrical field surrounding it. The magnitude of this field diminishes with distance. It is possible (58), by arbitrarily placing a single positive charge at various short distances out from the charged groups on the surfaces, and by making use of Coulomb's law (65) in which the force of attraction and of repulsion varies inversely as the square of the distance, to gain some notion of the variation of the resultant field around a particle. In general the resultant effect is such as to give strong local areas of positive and of negative fields close to the surface of the particle, while weaker resultant fields occur farther away (58). The net charge may be effective only at distances of 50–100 Å and may be either positive or negative. It may be thought of as the algebraic sum of the positively and negatively ionized residues.

An additional feature of the protein molecule which may prove to be significant when considering attachment of other molecules is that concerned with residue arrangement. The frequency of distribution along the chain of polar residues, such as lysine with an amino group and glutamic acid with its carboxyl group, has a strong bearing on the location of these groups on the surface of the particle. It has long been realized (66) that, given twenty different kinds of amino acid residues with no restrictions as to the relative number of each, it is possible to obtain millions of different proteins on the basis of composition alone without considering the number of additional types possible when their arrangement is also varied. Recent experimental studies (67, 68) of quite homogeneous proteins, using carefully tested methods of amino acid analysis, seem to indicate that the residues do not occur in random amounts but instead are present to the extent of $1/2$, $1/3$, $1/4$, $1/6$, $1/8$, $1/9$, $1/12$, $1/16$, $1/18$, $1/36$. . . etc., of the total residue number. Although this generalization may be based on insufficient experimental evidence, it furnishes an indication that some numerical rule may be involved in the synthesis of the protein molecule in the living cell. This observation has led to the hypothesis (67, 68) that the various amino acid residues may occur at constant intervals along the protein chain. Thus if there are 24 glutamic acid residues in a chain of 288 residues a uniform spacing along the chain will place one at every twelfth residue position; if there are 32 lysine residues,

every ninth will be of lysine; and so on for the various amino acid residues.

While this notion of residue distribution still needs more supporting evidence, there seems to be at least a probability, from the biological point of view, that a certain amount of orderliness must prevail in the formation of proteins. We are accepting this as plausible and are making use of it in a general way since it serves as a basis for the arrangement of the residue end groups into patterns or mosaics both on the surface and inside of the particle. Thus, if it is necessary that the glutamic acid and lysine residue endings occur at a specific distance from each other in order that a fatty molecule or a respiratory prosthetic group may be attached, their distribution may allow this to occur only once on a surface or at most only a few times.

Of the molecules occurring in cytoplasm which are thought to play an important part in the structural features of protein aggregates the fatty materials stand out as the most prominent. They occur in active protoplasm in quantities of at least ten to fifteen molecules for every protein molecule of 36,000 molecular weight. They form a miscellaneous class in which the common feature is the excessively large amount of carbon-hydrogen groups and the relatively infrequent occurrence of oxygen and nitrogen atoms. The significance of these proportions of component atoms comes out when it is recalled that the oxygen and nitrogen atoms have a strong affinity for water due to their negative residuals, while the carbons are lacking in this attraction for water. The resulting insolubility in water has led us to think of these materials as fatty substances.

The long-chain fatty acids, the neutral fats which are glycerol esters of the long-chain fatty acids, the phospholipids, and the sterols are included in this group. Of these the two most constant and ubiquitous in occurrence in cytoplasmic material are the phospholipids and sterols (69, 70, 71). At least three methods indicate that these materials may be found associated with protein material within the heavier cytoplasmic granules. The methods include solubility or dispersal of the large particles in fat solvents (72, 73, 74, 75, 76), blackening with osmic acid indicating the presence of unsaturated fatty acids (77) and detection of the aldehyde grouping of the acetal-phospholipids (78).

The phospholipids include two general groups, the ester-phospholipids represented by lecithin and cephalin and the recently discov-

ered acetal-phospholipids (78). Lecithin may be thought of as a modified fat in which one of the three fatty acid radicals is replaced by phosphoric acid plus a nitrogenous group, choline. Figure 6

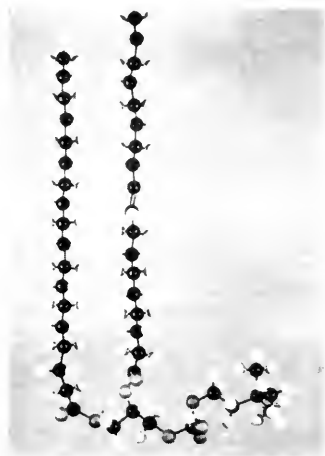

FIG. 6. Model photograph of a lecithin molecule. Length parallel to hydrocarbon chains is equal to approximately 25Å.

shows a model of lecithin with its characteristic polar and nonpolar regions. Approximately half of the phospholipids found in typical animal cells are lecithins. The other half is composed largely of cephalin, which differs from lecithin mainly in the fact that the choline portion is replaced by colamine, or amino-ethyl alcohol.

Concerning the ionization of the phospholipids it has been pointed out (79) that lecithin and cephalin ionize as shown in the diagram in Figure 7. The isoelectric point of the former is about pH 6.7 (80). It seems probable that in the case of lecithin both groups, phosphoric acid and choline, are ionized at the pH of cytoplasm (79, 81, 82, 83). Cephalin, on the other hand, has a weaker basic group (84) and may be

only partially ionized in cytoplasm. This makes it possible for certain of the cephalin molecules to exist with a negative charge.

For many years organic chemists (71) struggled with a large group of fatty compounds which apparently bore some structural

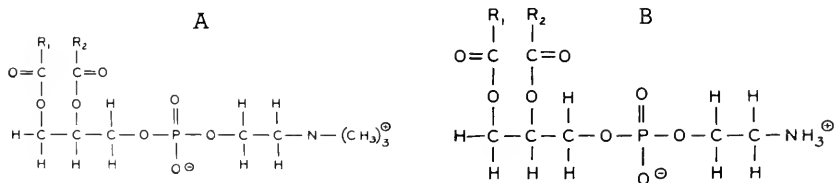

FIG. 7. Diagrams to show ionization of lecithin and cephalin. A. Zwitterion form of lecithin. B. Zwitterion form of Cephalin.

relation to one another even though they were widely different in their physiological effects (sex hormones, etc.). It is due to the efforts of the X-ray analyst, however, that this work crystallized into

our present understanding of the large group of compounds known as the sterols (85). The common feature of the sterols is now known (71) to be a complex ring system plus miscellaneous small side chains forming, in general, a rather flattened molecule about 5 Å in thickness, 7-7.5 Å in width, and approximately 20 Å in length (85). Minor structural variations give rise to the various sterols of which perhaps the best known are cholesterol (86), shown in

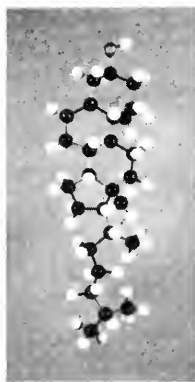

FIG. 8. Photograph of model of Cholesterol. Black balls indicate carbon atoms; grey ball at bottom, oxygen atom; and small white ones, hydrogen.

Figure 8, and ergosterol. They are found in both plants and animals; those in the higher plants are generally termed phytosterols. At the present time very little is known of the specific role, either structural or physiological, of the sterols in the living cell.

In addition to the proteins and fatty substances which occur in relatively large amounts in cytoplasm, a small quantity of organic molecules of great diversity play an important part in the activities of the cell, although in the structural framework they are insignificant. A considerable number of them are known to be involved in respiration, and when attached to proteins as prosthetic groups form the active part of cellular mechanisms, or enzymes (87). Most of these have been shown (64, 88, and 89) to occur in conjunction with specific proteins which appear to be albumins and globulins.

The existence of cytoplasmic granules which show intense respiration and hence contain respiratory prosthetic groups has been amply demonstrated in preparations from materials such as *Arbacia* eggs (126, 127), liver tissue (128), pig's heart muscle (12), and the breast muscle of the pigeon (13). It has been reported (111) that similar material, containing lipoids in addition to protein and respiratory prosthetic groups, has been isolated from normal chick embryo. The association of these three materials in cytoplasmic aggregates seems to be more generally recognized as experimental work progresses (111).

In order to show the diversity in structure of these small molecules, a list of the better known is given, with here and there photographic reproductions of molecular models and brief discussions concerning the individual dimensions and properties. The model photographs in Figures 9-12 inclusive are made to the same

scale as the portion of the protein chain in Figure 9D in order that dimensional comparisons may be made.

The most natural classification of these small molecules is that based on structure. The list may be a bit misleading for it is not known whether all of these occur in all living cells or in what amounts the various forms are associated in a single cell. The list is given on the assumption that many of them occur in every living cell and that the list is not exhaustive (88, 89).

They may be sorted out into about six general classes. The first three include the alcohols and carbohydrates, the aldehydes, and the organic acids, such as ascorbic (90), succinic, malic, pyruvic, lactic, and amino acids (Fig. 9).

The fourth group consists of larger molecules called nucleotides, which are composed of phosphoric acid, a sugar, and a nitrogenous base arranged in the order given (8). They may occur as single forms, such as riboflavinphosphate (91) and adenosine pyrophosphate; as dinucleotides, such as flavine-adenine dinucleotide (92) and diphosphopyridine nucleotide (93); and as tetranucleotides (94), such as nucleic acid. These vary mainly in the nitrogen-containing groups (Fig. 10).

The fifth group includes the metal-containing prosthetic groups (95, 11), such as cytochrome, containing iron (96); chlorophyll, containing magnesium (Fig. 11); and certain copper-containing groups (95).

The sixth group consists of molecules containing sulfur, such as glutathione (88) and thiamine pyrophosphate (97, 98) (Fig. 12).

This partial listing and brief discussion of the fatty materials and smaller molecules which act as prosthetic groups of enzymes

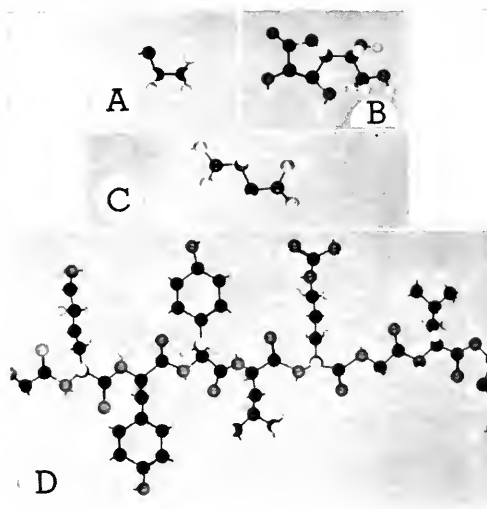

FIG. 9. Photographs of models of various types of small organic molecules. A. Ethyl alcohol. B. Ascorbic acid. C. Succinic acid. D. A portion of a protein chain made to same scale as the small organic molecules.

give us a somewhat broader view of the molecular constituents of the particles in cytoplasm. Of the dozen or more prosthetic groups, each has its own specific protein molecule, at least *in vitro*,

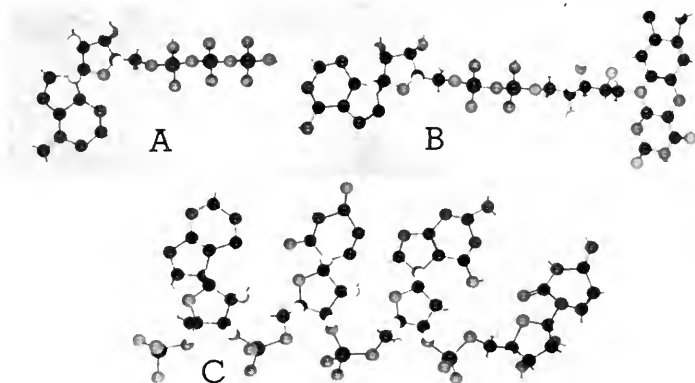

FIG. 10. A. Adenosine triphosphate, a nucleotide plus two phosphoric acid groups. B. Flavine-adenine dinucleotide. C. Nucleic acid, a tetranucleotide.

to which it may be attached. If we think of the attachment as being associated with the patterns or mosaics formed by end groups of particular amino acid residues on the surface of the protein particle, then a specific protein may mean that in order to fit a prosthetic group of one sort the configuration of the chain is different than when it fits another prosthetic group. In other words it may not mean that the amino acid composition of the chain is necessarily different in order to have specific properties but that merely a difference in configuration or arrangement of the chain lengths in the particle would suffice, since this would alter the patterns formed by the residue end groups.

With these conceptions of the spatial and electrical properties of the various constituents of cytoplasmic particles, we see the need for restrictions or limitations on the infinite number of ways in which these materials could aggregate to form cytoplasmic particles; without these a future comprehension of the larger structures seems practically impossible. This aggregation, it has been pointed out (99), may be brought about by means of three sorts of bonding forces: primary valence bonds, such as cystine bridges; bonds due to electrostatic forces, such as charged groups, or ions; electrostatic effects as observed in hydrogen bridges; and van der Waals'

cohesion forces. The most important of these are the electrical effects arising from the existence of ionized groups, since they may act at considerable distances as well as at close range, while the

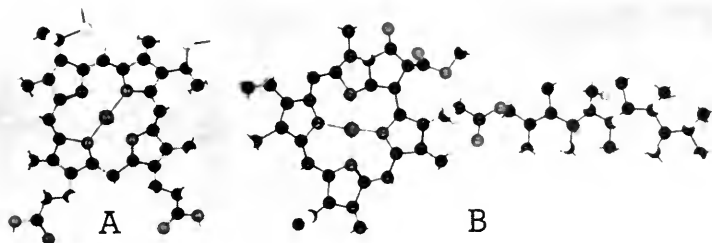

FIG. 11. A. Portion of the prosthetic group of Cytochrome c. B. Chlorophyll
A. The large central ball in the porphyrin ring represents iron in Cytochrome and magnesium in Chlorophyll.

other types are effective mainly at short distances, a matter of 1 to about 5 Ångstroms.

Here, again, we come to the borderline between the physical-chemical and the biological viewpoints. Aggregates formed by all possible combinations of these various molecules would produce merely a heterogeneous mixture in the cell, while opposed to this, organization is characteristic of the living protoplasm. Nevertheless, the various means of attachment, no matter how they are brought about, are undoubtedly the same in living as in inert matter; and

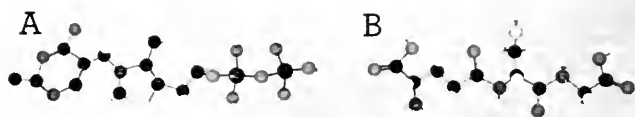

FIG. 12. A. Thiamine pyrophosphate (97, 98). B. Glutathione, glutamyl-cysteinylglycine (88). The very lightly-colored ball near the middle in each model represents a sulfur atom.

while it seems probable that the discrete molecules and particles, such as we have selected from the proteins, fats and other organic molecules, may not take exactly the same relative arrangement in space *in vivo* as they do *in vitro*, comprehension in the latter seems likely to aid in an understanding in the former.

To this end a few points concerning the attachment of various combinations of molecules is introduced. We need not dwell on the

cross-linkage of a residue on one chain to a residue on an adjacent chain by means of primary valence bonds. These are merely chemical bonds such as in any molecule. We are more interested in what may be termed cohesion bondings through electrostatic and van der Waals' forces. In all cases of combinations of molecules we are thinking of the protein as being especially prominent, and therefore we are concerned with the surfaces or faces of the protein particles.

It will be recalled that certain faces of the 50 Å protein molecule may have as many as fifty to sixty residue end groups exposed, forming some sort of mosaic pattern. On this only about ten to twenty are likely to be polar, and perhaps even fewer are ionized. Thus the face will have patterns also based on ionized groups. Some of these will be positively, some negatively, charged. The effect of these charges is strongly localized at a short distance above the surface, and resultants of these begin to appear as the distance from the face increases, first in accordance with the arrangement of the charges with respect to one another on the surface; and farther out, perhaps at 50 Å or more, the resultant effect is a blend of all charges, internal as well as those on the surface, or is, in effect, the net charge, or the algebraic sum, of all of the charges on the particle. Interaction of two such particles may occur, providing their net charge is opposite in sign. The resultant attraction of unlike and the repulsion of like charges should produce a mutual rotation of one particle with respect to another until their most attractive surfaces become adjacent. The surfaces should then turn until they reach a position of best fit (99). There is some doubt as to whether the particles would be able to make direct contact because of the possible presence of a 10 Å layer of "electrically saturated" water (16) around the ionized groups on their surface; that is, water which is completely polarized and oriented. As the two oppositely charged particles approached each other, they would reach a point at a separation distance of about 20 Å where their shells of similarly oriented water molecules would touch; if their attraction for each other is not large, it is possible that this might act as a barrier to further approach (100). However, in protoplasm other aggregating mechanisms may aid in squeezing out the water molecules and in bringing the elementary protein particles into more intimate contact. For example, van der Waals' attractive forces (19) become effective at short distances of particle separation, and as the particles approach still closer, hydrogen bridges between polar residues may become

possible in addition to direct ionic linkages and cystine bridges. Thus all three types may be influential in the production of aggregates of protein particles. The more complementary the two faces are to one another, the greater their interaction should be (99).

Van der Waals' forces (65) are effective between all types of atoms, while hydrogen bridges and ionic linkages, on the other hand, are only possible between groups containing oxygen and nitrogen atoms (19). Ionic linkages are possible only between oppositely charged residues, such as ionized lysine and aspartic acid. In both hydrogen bridges and ionic linkages, the atoms involved will approach to a separation distance of approximately 2.8 Å (19, 65) in contrast to 3.5–4 Å for van der Waals' distance (101). A primary valence bond, as in a cystine bridge, brings the bonded atoms to a distance of approximately 1.5 Å (19).

The relative stability of these linkages is of interest. Ionic linkages and gross electrical effects are markedly affected by changes in hydrogen-ion concentration (102). In addition to this, cystine bridges are influenced greatly by the concentration of electron-donating systems within the cell. Van der Waals' forces, on the other hand, are practically independent of these two factors. Temperature, of course, affects all forms of cohesion.

Recently evidence has been accumulating which indicates that phospholipids and sterols may occur bound to the protein material (103). That the zwitterion portion of lecithin and cephalin, previously shown in Figure 7, may be effective as the means of attachment is indicated by the similarity in the distance of 7 Å between the positive and negative charges on the lecithin, and the distance of 7 Å also between adjacent amino acid residues of the protein. The lecithin might then become attached to two adjacent, oppositely ionized residues of the protein through ionic attractions, or the phosphoric acid group might bridge to a hydrogen-donating residue, such as serine or tyrosine. If attached to the protein as shown in Figure 13, it would project out about 25 Å from the ends of the amino residues (104, 105). In certain instances the phospholipids may act in blocking specific residue patterns where respiratory prosthetic groups might otherwise become attached.

Concerning the attachment of the smaller molecules, the respiratory prosthetic groups, to protein particles, it seems too early to make much more than suggestive statements, but one thing at least may be sensed from the work which has been done; that is, degrees of specificity seem to exist, or rather, some prosthetic groups may be

much more exacting than others in the type of residue or residue combination to which they can become attached. For example, small, uncharged organic molecules, such as acetaldehyde, ethyl alcohol, etc., may require only a single polar residue; whereas small ionized monocarboxylic acids, such as formic and acetic, may require either a hydrogen-donating residue or a basically ionized group; while others, such as hexose-diphosphate and the dicar-

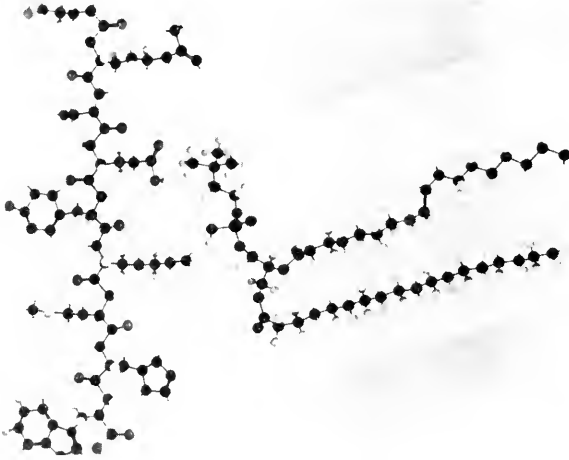

FIG. 13. Model photograph showing dimensional relationship between adjacent amino acid residues on the protein and the possible points of attachment on the phospholipid.

boxylic acid, succinic, may require two adjacent residues for attachment and proper orientation for reaction (Fig. 14). In some of the nucleotides only the ionized phosphoric acid group may attach to the protein (106); while nucleic acid may require four adjacent, positively ionized residues, such as those of arginine, for attachment to its four negatively charged phosphoric acid groups. Evidence (107) is accumulating which indicates that diphosphothiamine may require two points of attachment, i. e., its phosphoric acid group and the amino group of its pyrimidine ring. A somewhat similar attachment was suggested for lactoflavinphosphate (108, 109).

Degrees of specificity seem still more evident when it is noted that in certain instances where two adjacent residues are required, any two of seven different polar endings may be satisfactory; while in other cases a more restricted combination is necessary. The relative lengths of the adjacent residues may further restrict or

limit residue specificity; for example, if a hydroxyl group is needed adjacent to an arginine residue ending, serine may be too short and only a tyrosine residue would suffice to furnish the hydroxyl.

Again, in some instances, a large specific area consisting of as many as four to six specific residues properly placed may be required on the surface in order to provide for not only the active prosthetic group but also for the substrate molecule with which it reacts; for

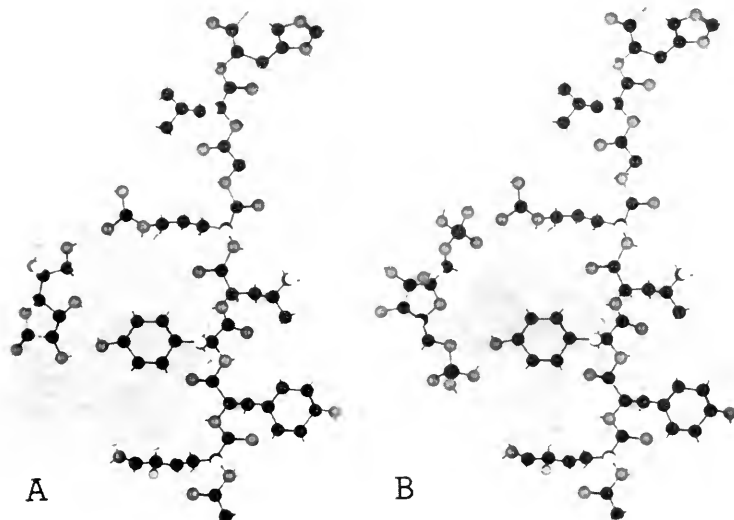

FIG. 14. Photographs of models showing dimensional relationship between: (A) Ascorbic acid and adjacent amino acid residues; (B) Hexose diphosphate and adjacent residues.

example, in the case of the pyridine nucleotides (110) the protein determines the kind of substrate molecule with which it may react.

A further instance, one in which the conception of a prosthetic group attached to the face of a particle gives way to a more complex structure, is seen in the enzyme, cytochrome. It has been said (111) "the heme residue is linked in two different ways to the protein, viz., by stable main valency bonds between the protein and one or two vinyl side chains of the porphyrin, as well as by the usual coordinate bonds between the central iron atom and some hemochromogen-forming groupings in the protein component." To accommodate this complex attachment the flat prosthetic group, shown previously in Figure 11, would have to be partially enclosed by the protein chains (129). From such examples as these, where experimental evidence

points obviously to the necessity for attachment of certain small molecules to specific larger ones in order to bring about particular activities, and where the only means of attachment is through a few sorts of residues restricted to limited localities on the larger

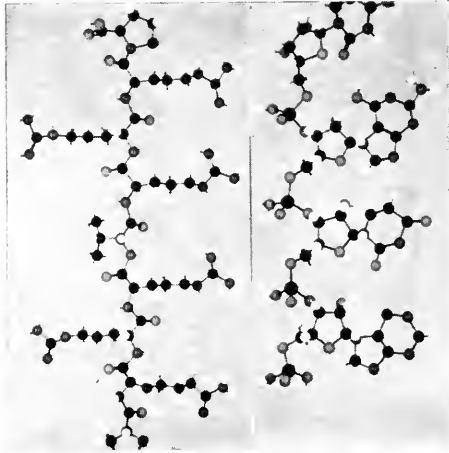

FIG. 15. Nucleic acid, a tetranucleotide, plus a protein showing dimensional relationship between four phosphoric acid groups and four adjacent amino acid residues.

molecule to specific larger ones in order to bring about particular activities, and where the only means of attachment is through a few sorts of residues restricted to limited localities on the larger molecule, the conception of specificity is given a spatial as well as a structural connotation.

There is still one more class of components which is involved in the construction of particle aggregates in cytoplasm; this comprises the inorganic ions. In general the interactions of these small ions and the protein molecules are of two sorts;

the ions may attach to the protein, and the protein may have a displacing effect on the neighboring ions in the surrounding medium. The kind and number of ions adsorbed will depend upon the nature and distribution, both quantitative and spatial, of the charged groups on the protein particle. The monovalent ions, Na^+ and K^+ , will have some tendency to associate with ionized carboxyl groups, but the divalent ions, Ca^{++} and Mg^{++} , will have a more pronounced tendency to become absorbed (112, 7). The negative ions, NO_3^- , SO_4^{--} , and PO_4^{---} , have been shown to associate with basic proteins (113) probably with the residues of lysine, histidine, and arginine. Studies of the displacement of the isoelectric point of various proteins with changes of ion concentration of the solution (7, 114) give evidence of ion association with the protein.

These examples of aggregation in which only one protein molecule is involved with another protein, or with a fatty molecule, or with another small organic molecule, or an inorganic ion, are instances of simple interactions involving only two molecules at a time. It

seems probable, however, that in the living organism several organic molecules and ions become attached to a single protein molecule to form a complex aggregate (115). The complexity to which this is likely to lead may be brought out by referring to the composition of active protoplasm as given in Table 2 where an average situation is shown based on one molecule of protein of molecular weight 36,000. A content of 2 per cent for the fatty materials (69) corresponds to about 10 molecules, such as those of the phospholipids, and the percentages of remaining materials indicate about 20 small organic molecules and perhaps 50 to 100 inorganic ions, also present on the average for each protein molecule of this size. The small organic molecules include principally such substrate molecules as those of hexose, triose, etc., since analyses indicate very small amounts of the pyridine nucleotides (116) of cytochrome (117), thiamine-pyrophosphate (97) and riboflavinphosphate (118). In fact, computations show the number of these to be only 1 pyridine nucleotide to about 20 molecules of protein of the size mentioned; 1 cytochrome to about 500 to 600 protein; 1 thiamine pyrophosphate to about 1,700, and 1 riboflavinphosphate to about 1,300 protein molecules of 50 Å size.

If we now think of the protein as a cube of 50 Å with six faces and about ten polar amino acid residues on at least four faces, we will have perhaps fifty potential places of attachment for the various smaller molecules and ions, and in all there must be at least 150 molecules and ions available in the cytoplasm for each protein particle of 50 Å in size, thus making it seem probable that some of the small organic molecules are not attached to the protein but instead are contained in the channels and submicroscopic vacuoles.

We now have some comprehension of an elementary protein particle to which several phospholipids as well as several inorganic ions and perhaps a respiratory prosthetic group are attached. In the living protoplasm, however, it seems reasonably certain that several or many complexes of this sort are attached to form larger and structurally more complex aggregates which serve particular purposes. Down in the lower submicroscopic region, however, relatively little is known concerning the aggregation of these conjugated proteins with one another; further, there is very little evidence concerning the quantitative distribution and localization of these materials throughout the cell.

Aggregation of a number of small 50 Å protein particles into a larger complex involves the nature of the outer faces of the particles,

the number and distribution of the polar residue end groups. If the particles could come together, face to face, a rather solid protein complex would be formed; but with the large number of phospholipids and smaller organic molecules present in protoplasm it seems likely that some of them would intervene and prevent close face-to-face attachment. We would expect, then, a rather wide separation of perhaps 25–50 Å due to the presence of the long hydrocarbon chains of the phospholipids on some faces and less separation due to the smaller organic molecules on other faces. It should be pointed out also that inorganic ions may prove to be of considerable importance in the formation of loose and transitory aggregates (122).

If we allow ourselves to speculate somewhat concerning the internal construction of the larger particles consisting of an aggregation of perhaps thousands of these complex, conjugated proteins, it seems reasonable to think that rather compact regions may occur in addition to regions in which, either due to the overlapping of particles or to loose aggregation (122), submicroscopic vacuoles occur. It is possible that it is in these regions that many of the "vital" activities take place. In other words, the complex aggregates of many simple 50 Å particles are likely to be relatively porous with some small and some large submicroscopic vacuoles. These loose, spongy, complex aggregates may consist of a thousand component protein particles, interpenetrated with water channels which widen here and there to form the internal vacuoles, or "reaction chambers" as they have been called (123). The walls of these "chambers" are the faces of the protein particles to which fatty materials and respiratory prosthetic groups may be attached, probably in some specific pattern. The "chambers" may be relatively isolated from one another within the same complex and are likely to vary somewhat in their activity towards a substrate molecule. It seems possible that the substrate molecule may be transformed in one manner in one "reaction chamber" and in quite a different manner in another. By this means a channeling of reactions may occur which would not take place if these materials were mixed and distributed in any other fashion. Such a definite arrangement may be considered as one phase of *organization* in the particle as a whole.

The existence of complexes, whose activity depends upon the integrity of the whole and whose organization is relatively easily disturbed, has been demonstrated recently (14, 124, 125). The need for such particular specific internal arrangements between the respiratory components has been sensed for some time (111), and it

seems probable that many vital activities take place in such organized structures.

With this conception of aggregates in which protein molecules with attached smaller organic molecules are in turn held together by cohesion forces of the same sort, hydrogen bridges, ionic bondings, and van der Waals' forces, the enormous number of submicroscopic granules in the fluid cytoplasm begin to take on the suggestion of individual characteristics. Some may be too small or too simple to perform any particular activity; others, although complex enough, may be nonfunctional because they do not contain the proper constituents or because of unsuitable arrangement of the constituents; while some are definitely functional in character. A functional aggregate is comparable to a large "floating laboratory" in which a variety of separate, although coordinated projects are being carried out.

Throughout this discussion, in which we have been concerned with the molecular components of protoplasm and with the manner in which their constituent atomic and molecular groups would allow them to fit together, we have made use of the "particle" as a means of keeping the molecular characteristics constantly in sight; and although this has been a convenient means, it is based on *in vitro* experimentation almost exclusively. The obvious question of the biologist is: To what extent is it applicable to the living state? The principal difference seems to lie in the random nature of the *in vitro* world and the organization of the materials in the *in vivo* world; further, in the living cell the functional aggregates are formed in the presence of organized structures, of pre-existing mechanisms or patterns.

We have come to a point where we wonder whether the elementary molecules interact simply by chance as recognized by statistical methods or, instead of this freedom, have some orderliness brought into their relationships by restrictions imposed upon them by their living environment. The nature of this orderliness in construction must be consistent with the behavior of the living cell, and our way of thinking must now be altered to include the biological, as well as the chemical-physical, statistical point of view. At this stage it now becomes a matter of not what possible things can happen to protein particles and to the other component molecules to transform them into protoplasm, but instead, what has happened to bring about the construction of active protoplasm from which these organic molecules were obtained.

Perhaps it will clarify matters somewhat if we start with the raw materials available to the plant and attempt to trace, in a general way, their formation into larger aggregates. Inorganic ions and water molecules are brought into the plant where carbon atoms from carbon dioxide have already been bound together into short carbon chains with hydrogens and oxygens attached, as in glucose. These we may think of as the basic substances. They are not combined at random to form various substances, but instead are brought into the presence of an already existing protoplasm, where only particular constructions are permissible. The protoplasm present is a "going concern" consisting of mechanisms which are capable of converting these raw materials into particular molecular structures. We now become confronted with the matter of construction, or shall we call it synthesis. But synthesis of what, of more protoplasm, in place, from basic materials, a sort of accretion; or of more mechanisms similar to those already existing as component structures of the protoplasm; or synthesis of large molecules, as those of protein, which we may think of as building blocks used for construction of the mechanisms? In other words, where does chance, as exemplified by random interaction, enter into the formation of new protoplasm, and at what stage does the pattern of pre-existing materials cease to be of significance?

We are rather rapidly heading towards a dynamic picture, yet it is the static, or only a single frame from a movie film, with which we would momentarily be satisfied. If we should discover that it is the larger molecules which are synthesized, then we have the task of finding how they are put together to form a mechanism; and when we know that, we still have to discover the organized arrangement of the mechanisms which will produce active protoplasm. We have omitted to mention synthesis of smaller molecules of which the larger seem to be composed. The queries come up, which we repeat although difficult to formulate clearly, as to whether the new protoplasm is built up by accretion *in situ* from the basic small-molecule materials, or by addition of large already-elaborated molecules to the existing protoplasmic structures, or by bringing already-built mechanisms into proper relations for protoplasmic activity. The difficulty of merely stating the questions is probably evident.

Many additional queries arise concerning "mechanisms," the simplest of which may be the respiration complex which we have just considered in a general way. Here the nature of the complex is not yet well established, although small molecular mechanisms, en-

zymes in this case, are fairly well known (64). The larger complex is thought to consist of several different enzymes which function in a series, one reaction following another in more or less gradual steps leading eventually to the disintegration of glucose. Each of the enzymes consists of a protein molecule and a prosthetic group. The prosthetic groups, at least several of them, are known; and of the protein, the molecular weights of some are known, but little more information is available concerning them except that they are specific for their particular prosthetic groups. The steps in the disintegration process are known to some extent although not completely; we know the materials which go into the machine and the details of a considerable amount of the disintegration as well as the final products; thus here we have the parts of the machine and know how they perform by themselves, but we do not know how to put them together to form the complete structure; that is, we are ignorant of the arrangement of the small mechanisms in the complex as a whole.

Recent evidence makes it seem probable that these small respiratory mechanisms may be associated with still other small mechanisms to carry on even more complex activities. For example, the presence of copper and iron along with chlorophyll, proteins, and lipoids has been shown in isolated, intact chloroplasts (119, 120), thereby indicating that respiratory mechanisms are probably associated with photosynthetic mechanisms in the minute chlorophyll-containing portions. Concerning this synthetic process we know with a considerable degree of certainty that the raw materials which go into the machine are carbon dioxide and water and that the products which come out are glucose and oxygen; and we know here also the molecular nature of part of the machine, the energy-absorbing chlorophyll molecule and in general the protein chain. This is a step in advance of the leucoplast where the material going in, glucose, and that coming out, starch grain, are known, but concerning the molecular structure of the machine, practically nothing is known except that it probably is mainly protein. In contrast to the chloroplast, however, here the end product, the starch grain, is microscopically visible.

In the microscope we see a leucoplast as a complex mechanism, but as though at a great distance, for the details are invisible, although the output of starch grain is seen. Here we see a mechanism as a whole but know nothing of the smaller component mechanisms or of their molecular details. By taking the starch grain apart we have learned that the mechanism is capable of condensing glucose

molecules and placing them in an orderly manner to form the starch grain. It seems probable that, in detail, there are many small mechanisms within the plastid which are active in placing the glucose molecules on the surface of the grain and also in producing an ether linkage between them. Actually we know only that the starch grain becomes larger; to our mechanistic minds there must be machinery of some sort, but of its construction we know very little. In the plastid we think of an orderliness of some sort, in the placement of the machinery which produces starch grains, since the shapes of the starch grains are fairly specific with plant species, and as a matter of fact, the behavior of the starch itself is in some respects almost as specific as the structures of the grains. Despite this, it seems fairly reasonable to think that the individual mechanisms which bring about the condensation of glucose to starch are more or less universal in plants.

From the biological point of view we think of the plastid as a very large particle. Shall we think of its growth as consisting of a building-up process, in place, from small molecules, or large molecules as of protein, or from ready-made small mechanisms? We come to similar questions concerning a large protein molecule of some thousand atoms. Is there a machine to manufacture these with the proper amount of amino acids for each species and for each mechanism where several specific proteins are apparently needed as in respiration? Or is it more likely that the protein molecules are merely the wreckage of the larger mechanism complexes which were built by accretion of the small basic molecules? Questions of this sort and the discussion of them leads primarily to a demand for experimental answers, and each small point is likely to mean a large experimental task.

Concerning these questions which have been posed here, there is undoubtedly much more information in the literature than is known to any one of us. Some of it is based on cytology or allied subjects; some on morphological, some on physiological and some on other biological procedures. Here and there are items in chemical and physical journals. Our questions involve the interpretation of biological experiments from a physical and chemical point of view; for example, the microscopic measurement of the rate of deposition of a growing cell wall, the transverse septum of an algal cell (121). This is a biological experiment, yet the interpretation of these measurements into the rate of deposition of glucose molecules is chemical in that it gives a rate of ether linkage formation, and physical in that the process of crystal formation may be studied.

Experimental work is greatly desired which takes the molecular viewpoint into consideration even though the direct purpose of the experiment is based on a higher dimensional level. On the other hand it may be possible that the molecular viewpoint and the sub-microscopic viewpoint, where molecular structure of the particle is taken into consideration, will help to direct the experimental attempts to answer the many questions which are constantly arising. Suggestive bits of information come out of the molecular dimensional models and also from the conception of cohesion forces in their manner of holding molecules and particles together. This information seems directly applicable to the materials of protoplasm, for regardless of whether we are dealing with large molecules, with mechanisms, or with the summation of these into a protoplasmic mass, we still are dealing with atoms and atomic groups and with the forces which are involved in their interaction and in the formation of molecular structures. Further, the atoms and the molecular groups occupy specific amounts of space which must be reckoned with in their movement within a concentrated mixture, especially when organized to the extent of cytoplasm.

SUMMARY

A very short summary may help to point out what we consider to be important in forming conceptions of molecular structure, as we now think of it in protoplasm. Specifically, the atomic radii and their directive valence angles should be the same *in vivo* as *in vitro*. They give shape and size to structures on the molecular level and should actively influence structure on higher levels. The primary valence bond may be considered as furnishing the binding strength and closeness of atomic approach necessary to make the molecule an entity.

The manner of attachment of molecules and particles to one another must be the same in the cell as *in vitro*; that is, by means of H-bridges, ionic and van der Waals' attraction. The H-bridge is effective directly between two atoms of oxygen and nitrogen only. Ionic forces of attraction may be effective in a similar individual manner between oppositely charged groups; and also as a resultant of several or many charges. Thus particles may be held together by several negatively and positively charged atoms pairing up directly and also by the resultant field produced by all of the charges on the particle, within as well as on the surface. Van der Waals' forces act much less locally on a particle; instead, they act more like a diffuse field

around the particle as a whole. The strength of attachment will depend to such a great extent upon the specific nature of the approaching atoms and faces that little more can be said than that a considerable although a relatively limited number of variations occur. This must be evident when one considers the possibilities existent in the approach, face to face, of two protein particles. An H-bridge may be effective at one point, several ions may pair up at other points, and van der Waals' forces will always be effective when the surfaces are close together; that is, within 3 to 5 Å.

Attachment of prosthetic groups to the protein is thought to occur specifically. In some instances the small molecule may be bound directly to the protein through hydrogen bridges, in other cases through ionic pairing. Primary valence bonds and even van der Waals' forces are not to be excluded. The spacing between the atomic constituents which are thought to be active in the attachment of the prosthetic group to the protein was shown to be compatible in certain instances with the distance of about 7 Å between adjacent residues on the protein chain.

These fundamental concepts of molecular models and intermolecular forces of attraction make it possible to determine the nature of larger structures. The larger structures we may think of as particles at one moment, principally because we are familiar with microscopic particles in protoplasm; while at another moment we may think of them as mechanisms, because we know from experimental procedures that particles are involved in activities of various sorts. From the composition of the particles we are enabled to carry over the structural molecular concepts to the mechanisms, but only insofar as we know the composition of the mechanisms.

Organization of these mechanisms, in some as yet undetermined manner, in the cell, we assume at the present stage of investigations, constitutes the physical basis for vital activities. In conclusion, we feel that this organization within the cell, which is without doubt responsible for the phenomena presented by a living organism, is of such a nature that further elucidation of it may come from the application of the fundamental concepts mentioned, to experimental investigations involving both biological and physical-chemical procedures.

LITERATURE CITED

1. SPONSLER, O. L. *The Quarterly Review of Biology* VIII, 1, 1933.
2. GAIDUKOV, N. *Ber. d. Deutschen Bot. Gesell.* 24, 107, 155, 580. 1906; *Dunkelfeldbeleuchtung und Ultramicroscopie in der Biologie und in der Medizin*, Jena. 1910.

3. CHAMBERS, R. *Jour. Exp. Zool.* 23, 483. 1917.
4. BAYLISS, W. M. *Proc. Roy. Soc., Series B*, 91, 196. 1920.
5. PRICE, S. R. *Ann. Bot.* 28, 601. 1914.
6. TAYLOR, C. V. *Proc. Soc. Exp. Biol. and Med.* 22, 533. 1925.
7. LLOYD, D. J., AND A. SHORE. *The Chemistry of the Proteins*. Philadelphia. 1938.
8. SCHMIDT, C. L. A. *Chemistry of the Amino Acids and Proteins*. Baltimore. 1938.
9. SVEDBERG, T. *Proc. Roy. Soc. Lond.* 127B, 1. 1939.
10. KALCKAR, H. M. *Chem. Rev.* 28, 71. 1941.
11. BARRON, E. S. G. *Physiol. Rev.* 19, 184. 1939.
12. KEILIN, D., AND E. F. HARTREE. *Proc. Roy. Soc. Lond.* 125B, 171. 1938.
13. STERN, K. G. *Cold Spring Harbor Symposia on Quant. Biol.* VII, 312. 1939.
14. NEEDHAM, J. *Order and Life*. New Haven. 1936.
15. BERNAL, J. D., AND R. FOWLER. *Jour. Chem. Phys.* 1, 515. 1933.
16. DEBYE, P. *Polar Molecules*. New York. 1929.
17. CROSS, P. C., J. BURNHAM, AND P. A. LEIGHTON. *Jour. Amer. Chem. Soc.* 59, 1134. 1937.
18. BARNES, W. H. *Proc. Roy. Soc. Lond.* 125A, 670. 1929.
19. PAULING, L. *The Nature of the Chemical Bond*. Ithaca. 1939.
20. HUGGINS, M. *Jour. Org. Chem.* 1, 407. 1936.
21. SPONSLER, O. L. *The Cell and Protoplasm*. Science Press. 1940.
22. PEARSALL, W. H., AND J. EWING. *Brit. Jour. of Exp. Biol.* 2, 347. 1924.
23. SEIFRIZ, WM. *The Botanical Review* 1, 18. 1935; *Protoplasm*. New York. 1936.
24. FREY-WYSSLING, A. *Jour. of Roy. Micr. Soc.* LX, 128. 1940.
25. MOYER, L. This Monograph.
26. PARAT, M., AND J. PAINLEVE. *Compt. Rend. Soc. de Biol.* 94, 745. 1926.
27. GIROUD, A. *Protoplasma* 7, 72. 1929.
28. MILOVIDOV, M. P. *Compt. Rend. Acad. des Sciences* 187, 140. 1928.
29. SHINKE, N., AND M. SHIGENAGA. *Cytologia* 4, 189. 1933.
30. GUILLIERMOND, A. *Les Constituants Morphologiques du Cytoplasme: Le Chondriome*. Paris. 1934.
31. Volumes VI and VII of the Cold Spring Harbor Symposia on Quantitative Biology.
32. ASTBURY, W. T., AND R. LOMAX. *Jour. Chem. Soc. Lond.*, p. 849, June, 1935.
33. SPONSLER, O. L., AND J. D. BATH. In press. *Proc. Soc. Exp. Biol. and Med.*
34. KUNITZ, M., M. L. ANSON, AND J. H. NORTHROP. *Jour. Gen. Physiol.* 17, 365. 1933.
35. KUNITZ, M., AND J. H. NORTHROP. *Jour. Gen. Physiol.* 18, 433. 1935.
36. CROWFOOT, D. *Nature* 135, 591. 1935; *Proc. Roy. Soc. Lond.* 164A, 580. 1938.
37. BERGMANN, M., AND C. NIEMANN. *Jour. Biol. Chem.* 115, 77. 1936; *Jour. Biol. Chem.* 118, 301. 1937.
38. SVEDBERG, T. *Nature* 139, 1051. 1937.
39. BERNAL, J. D., D. CROWFOOT, et al. *Nature* 141, 521. 1938.
40. LOEB, J. *Jour. Gen. Physiol.* 4, 73. 1921-22.
41. CHICK, H., AND MARTIN. *Jour. Physiol.* 45, 261. 1912.
42. VON MURALT, A. L., AND J. T. EDSALL. *Jour. Biol. Chem.* 89, 351. 1930.
43. COHN, E. J. *Cold Spring Harbor Symposia on Quant. Biol.* VI, 8. 1938.
44. NEURATH, H. *Cold Spring Harbor Symposia on Quant. Biol.* VI, 196. 1938.

45. ASTBURY, W. T. *Cold Spring Harbor Symposia on Quant. Biol.* II, 18. 1934.
46. PAULING, L., AND C. NIEMANN. *Jour. Amer. Chem. Soc.* 61, 1860. 1939.
47. WYCKOFF, R. W. G., AND R. COREY. *Science* 81, 365. 1935.
48. ASTBURY, W. T., S. DICKINSON, AND K. BAILEY. *Biochem. Jour.* 29, 2351. 1935.
49. WU, H. *Chinese Jour. Physiol.* 5, 321. 1931.
50. ASTBURY, W. T., AND F. O. BELL. *Cold Spring Harbor Symposia on Quant. Biol.* VI, 109. 1938.
51. MIRSKY, A. E., AND L. PAULING. *Proc. Nat'l. Acad. Sci.* 22, 439. 1936.
52. ASTBURY, W. T., F. O. BELL, E. GORTER, AND J. VAN ARMONDT. *Nature* 142, 33. 1938; 143, 280. 1939.
53. SCHMITT, F. O. *Physiological Reviews* 19, 270. 1939.
54. SPONSLER, O. L., J. D. BATH, AND J. W. ELLIS. *Jour. of Phys. Chem.* 44, 996. 1940.
55. MITCHELL, H. H., AND T. S. HAMILTON. *Biochemistry of Amino Acids.* New York. 1929.
56. KARRER, P., AND W. KAASE. *Helv. Chim. Acta* 2, 436. 1919; 3, 244. 1920.
57. SPONSLER, O. L. Second Annual Symposium of the Society for the Study of Development and Growth. Growth, Supplement, pp. 1-26. 1940.
58. SPONSLER, O. L., AND JEAN D. BATH. To be published in the *Biological Reviews of the Cambridge Philosophical Society.*
59. HILL, T. L., AND G. E. K. BRANCH. *Science* 91, 145. 1940.
60. CHAMBERS, R. *Bul. Nat'l Res. Council* 69, 37. 1929; *The Harvey Lectures*, p. 49. 1926-27.
61. SMALL, J. *Hydrogen Ion Concentration in Plant Cells and Tissues.* Berlin. 1929.
62. SEIFRIZ, W., AND M. ZETZMANN. *Protoplasma* 23, 175. 1935.
63. COHN, E. J. *The Harvey Lectures*, p. 124. 1938-39.
64. GREEN, D. E. *Mechanisms of Biological Oxidations.* Cambridge. 1940.
65. SLATER, J. C. *Introduction to Chemical Physics.* New York. 1939.
66. FISHER, E. *Zeit. Physiol. Chem.* 99, 54. 1917.
67. BERGMANN, M. *Chem. Rev.* 22, 423. 1938.
68. NIEMANN, C. *Cold Spring Harbor Symposia on Quantitative Biology VI*, 58. 1938.
69. LEATHES, J. B., AND H. S. RAPER. *The Fats.* London. 1925.
70. MACLEAN, H., AND I. MACLEAN. *Lecithin and Allied Substances.* London. 1927.
71. GILMAN, H. *Organic Chemistry*, Vol. II, New York. 1938.
72. REGAUD, C. *Compt. Rend. Soc. Biol.* 65, 660. 1908.
73. FAURÉ-FREMIET, M. E. *Arch. d' Anat. Micr.* 11, 457. 1910.
74. LÖWSCHIN, A. M. *Ber. Deutsch. Bot. Gesell.* 31, 203. 1913.
75. LEWITSKY, G. *Zeit. für Botanik* 16, 65. 1924.
76. CHIBNALL, A. C., AND H. J. CHANNON. *Biochem. Jour.* 21, 242. 1927.
77. BENSLEY, R. B. *Anat. Rec.* 69, 341. 1937.
78. FEULGEN, R., AND TH. BERSIN. *Zeit für Physiol. Chem.* 260, 217. 1939.
79. FISCHGOLD, H., AND E. CHAIN. *Proc. Roy. Soc. Lond.* 117B, 239. 1939; *Biochem. Jour.* 28, 2044. 1934.
80. CHAIN, E., AND I. KEMP. *Biochem. Jour.* 28, 2052. 1934.
81. BULL, H. B., AND V. L. FRAMPTON. *Jour. Amer. Chem. Soc.* 58, 594. 1936.
82. GRÜN, A., AND R. LIMPÄCHER. *Ber. Chem. Gesell.* 60, 151. 1927.
83. RUDY, H., AND I. H. PAGE. *Zeit. Physiol. Chem.* 193, 251. 1930.

84. JUKES, T. H. *Jour. Biol. Chem.* 107, 783. 1934.
85. BERNAL, J. D. *Nature* 129, 277. 1932; *Jour. Soc. Chem. Ind.* 51, 466. 1932; *Ann. Repts. Chem. Soc. Lond.* 30, 423. 1933.
86. BILLS, C. E. *Physiol. Rev.* 15, 1. 1935.
87. LLOYD, D. J. *Biol. Rev.* 3, 164. 1928.
88. ELVEJHEM, C. A. *Respiratory Enzymes*. Minneapolis. 1939.
89. OPPENHEIMER, C., AND K. G. STERN. *Biological Oxidation*. New York. 1939.
90. GIROUD, A. *L'Acide Ascorbique dans la cellule et Les Tissus*. Berlin. 1938.
91. THEORELL, H. *Ergebnisse der Enzymforschung*. VI, 111. 1937.
92. WARBURG, O., AND W. CHRISTIAN. *Biochem. Zeit.* 298, 150, 368. 1938.
93. WARBURG, O. *Ergebnisse der Enzymforschung* 7, 210. 1938.
94. LEVENE, P. A., AND L. W. BASS. *Nucleic acids*. New York. 1931.
95. STERN, K. G. *Cold Spring Harbor Symposia on Quant. Biol.* VI, 286. 1938.
96. THEORELL, H. *Biochem. Zeit.* 298, 242. 1938.
97. LOHMAN, H., AND SCHUSTER. *Biochem. Zeit.* 294, 188. 1937.
98. STERN, K. G., AND J. W. HOFER. *Enzymologia*, 3, 82. 1937.
99. PAULING, L., AND M. DELBRUCH. *Science* 92, 78. 1940.
100. LANGMUIR, I. *Jour. Chem. Phys.* 6, 873. 1938.
101. ROBERTSON, J. M. *Chem. Rev.* 16, 417. 1935.
102. SVEDBERG, T. *Trans. Farad. Soc.* 26, 740. 1930.
103. HEILBRUNN, L. V. *Biol. Bul.* 71, 299. 1936.
104. SCHMITT, F. O., R. S. BEAR, AND G. L. CLARK. *Radiology* 25, 131. 1935.
105. SCHMITT, F. O. *Jour. Applied Physics* 9, No. 2. 1938.
106. BALL, E. G. *Cold Spring Harbor Symposium on Quantitative Biology VII*, 100. 1939.
107. HEEGAARD, E., AND E. R. BUCHMANN. Unpublished Experiments. 1940.
108. THEORELL, H. *Biochem. Zeit.* 290, 293. 1937.
109. KUHN, R., AND P. BOULANGER. *Ber. Chem. Ges.* 69, 1557. 1936.
110. WARBURG, O. *Ergeb. d. Enzymforschung* 7, 210. 1938.
111. STERN, R. G., *Ann. Rev. Biochem.* IX, 1. 1940.
112. GREENBERG, D. M., AND C. E. LARSON. *Jour. Phys. Chem.* 43, 1139. 1939.
113. ROBERTSON, J. B. *The Physical Chemistry of The Proteins*. London. 1924.
114. TISLIUS, A., AND H. SVENSSON. *Trans. Farad. Soc.* 36, 16. 1940.
115. VON PRZYLECKI, ST. J., W. GIEDROYC, AND H. RAFALOWSKA. *Biochem. Zeit.* 280, 286. 1935.
116. BERNHEIM, F., AND A. VON FELSEVANYI. *Science* 91, 76. 1940.
117. THEORELL, H. *Biochem. Zeit.* 298, 242. 1938.
118. GOURÉVITCH, A. *Bul. Soc. Chim. Biol.* 19, 527. 1937.
119. GRANICK, S. *Amer. Jour. Bot.* 25, 558, 561. 1938.
120. NEISCH, A. C. *Biochem. Jour.* 33, 293, 300. 1939.
121. SPONSLER, O. L. *Jour. Amer. Chem. Soc.* 56, 1599. 1934.
122. BERNAL, J. D. *The Cell and Protoplasm*. Science Press. 1940.
123. WARBURG, O. *Ergebnisse der Physiol.* 14, 316. 1914.
124. PETERS, R. A., AND THOMPSON. *Biochem. Jour.* 28, 916. 1934.
125. CASE, E. M. *Biochem. Jour.* 25, 568. 1931.
126. NAVEY, A. E., AND E. B. HARVEY. *Biol. Bul.* 69, 342. 1935.
127. SHAPIRO, H. *Jour. of Cell. and Comp. Physiol.* 6, 101. 1935.
128. WARBURG, O. *Pflüger's Arch. Physiol.* 154, 599. 1913.
129. THEORELL, H. *The Cell and Protoplasm*. Science Press. 1940.



The American Society of Plant Physiologists wishes to show its respect for the late Professor Herbert Freundlich by publishing his portrait as a frontispiece to his chapter in this Monograph. The article on Thixotropy which follows was the last manuscript written by Professor Freundlich. Rare was the contribution from Professor Freundlich's laboratory which did not enrich physiology as much as it did chemistry, and none had a greater influence on biological thought than did thixotropy.

Those who knew Professor Freundlich will remember him for his intense interest in biology and his broad understanding of it. Those few among us who had the good fortune to work in his laboratory will remember him as one of the most inspiring teachers, fair and tolerant colleagues, and gracious companions that a man could desire. His was a truly great character. Biology has lost one of its ablest and noblest friends.

SOME MECHANICAL PROPERTIES OF SOLS AND GELS AND THEIR RELATION TO PROTOPLASMIC STRUCTURE

HERBERT FREUNDLICH

Editor's Note: This article was found among the papers of the late Professor H. Freundlich in an unfinished state. The first part, dealing with the mechanical properties of sols and gels, seems to be nearly complete. No notes concerning the latter part were found. Except for minor stylistic alterations and correction of typographical errors, the manuscript is printed as found. The references and figures were added by L. Moyer and K. Sollner.

In older textbooks of physiology, let us say of about 1900, the state of aggregation of protoplasm is left very unclear.¹ It is frequently considered to be fluid. On the other hand, it is emphasized that life processes seem to require a well-defined "organization" and that such an organization can hardly be imagined without some kind of a more or less solid structure. There is practically no indication of the fact that the mechanical properties of protoplasm differ essentially from those of normal liquids or solids and that they may be correlated with its colloidal nature. References to colloids are found, if at all, when the impermeability of membranes to proteins, or swelling, or the scarcity of distinct crystals are discussed.

This outlook has completely changed during the last twenty years. It has been found that there may exist a number of intermediate stages between the normal liquid state and the state of a crystalline solid. These are frequently observed in colloidal systems, particularly if they contain a sufficiently high amount of disperse phase. Consequently, concentrated colloidal solutions may differ essentially in their mechanical properties (viscosity, elasticity, etc.) from normal, so-called Newtonian liquids. These differences may be manifold. Two limiting cases are of outstanding importance; the first is that of thixotropy. Whereas the viscosity of a Newtonian liquid is not changed by mechanical means, such as flowing or stirring, a thixotropic system becomes less viscous while flowing or when being stirred. This phenomenon is particularly obvious if we have a thixotropic gel: It is liquefied by shaking and sets again to a gel when at rest. We thus have an isothermal, reversible, sol-gel transformation.²

We are dealing with a thixotropic change, too, if the viscosity of a concentrated sol can be reduced by shaking or stirring and if it increases again when at rest. The viscosity of such a sol differs in other respects from that of a Newtonian liquid. It is anomalous, i.e., it does not obey Poiseuille's law for laminar flow; the amount of liquid passing through a capillary in a given time depends on the applied pressure in a different way. Speaking more specifically, the viscous resistance is not directly proportional to the velocity gradient of the laminar flow, as in Newtonian liquids. The characteristic behavior of anomalously viscous, thixotropic sols and likewise of thixotropic gels is correlated with the existence of a yield value. This can be demonstrated in a graphic way by using a viscometer, in which a ball is pulled through the viscous system in question by a weight which can be increased at will; for different weights the speed of the moving ball is compared.³ In a Newtonian liquid the speed is proportional to the weight applied (curve 1 in Fig. 1). In a thixotropic sol or gel we have a yield value (A): The weight must exceed a certain minimum to cause the ball to move; only with higher weights does its speed change in a way similar to that observed in a normal liquid (cf. curve 2 in Fig. 1). Curve 1 refers to glycerol, a typically Newtonian liquid, curve 2 to a thixotropic, aqueous iron oxide gel. In other cases we may actually have a less straightforward behavior: a curve which, at higher weights, is similar to curve 2 but which does not intersect the abscissa; instead, it is curved and passes through the zero point.

Systems showing anomalous viscosity also exhibit a characteristic behavior with respect to their electrical conductivity. The electrical conductivity of an aqueous solution is markedly influenced by its Newtonian viscosity; as a rule, it is, in a first approximation, inversely proportional to the viscosity. For instance, the electrical conductivity of an aqueous salt solution having a fairly high viscosity, owing to the presence of a suitable concentration of glycerol, is lower than that of a solution of the same salt concentration in pure water. The anomalous viscosity of a thixotropic sol or gel, on the other hand, leaves the electrical conductivity practically unchanged. The electrical conductivity of a salt solution remains the same, although it may contain so much gelatin that its apparent viscosity is about equal to that of the solution containing glycerol.⁴ It is well known that even gels of gelatin (containing electrolytes) or of soaps do not differ in their electrical conductivity from the sols from which they were produced.⁵ Presumably the movement of the

ions is not influenced by the structure of thixotropic sols and gels, which is very coarse compared to the small size of the ions.

Finally, not only gels but also sols of this type (gelatin, soaps, etc.) show elastic properties. Small solid particles suspended in such a sol may be moved by an external force but return to their

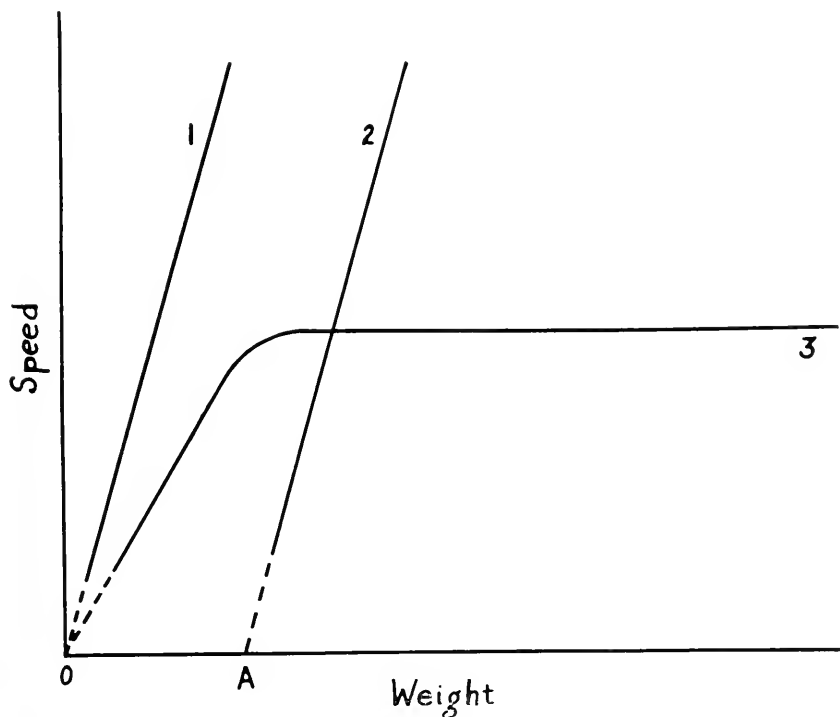

FIG. 1.

original position when the force stops acting, a phenomenon not observed in Newtonian liquids.⁶ This elasticity in sols is not found so regularly as the other characteristic properties just mentioned. The presence of distinctly rod-shaped colloidal particles is perhaps more decisive in causing elastic effects than it is with the other properties characteristic of this kind of anomalous viscosity.

Thixotropic behavior is not exceptional; it is very common, provided that suitable concentrations of the colloid are chosen. Examples are: thixotropic, aqueous gels of many oxides⁷ (aluminum, iron, scandium, vanadium, titanium, thorium, etc.), of colloidal

bentonite,⁸ of myosin,⁹ and tobacco mosaic virus,¹⁰ of dibenzoylcystine¹¹ and of barium malonate¹² in a medium of water and alcohol. Aqueous solutions of gelatin have been found to show thixotropy, both as concentrated solutions and as gels.¹³

Coarse suspensions containing particles with a diameter of 1μ and more may also be thixotropic: They behave as a liquid while being shaken and settle to a solid paste when shaking stops. This behavior is again found very frequently with aqueous suspensions of clays, slates (Solnhofen slate), and many powdered minerals (mica, iron oxide, jet, etc.)¹⁴; with finely powdered mercaptobenzothiazol in many organic liquids (benzine, carbon tetrachloride, chloroform, benzene, toluene, etc.)¹⁵; and in suspensions of many pigments in oils.¹⁶ Bentonite is a particularly good example of a substance forming thixotropic systems both in colloidal and in coarse suspensions.⁸ The mechanical properties of coarse suspensions are important because they enable us to understand better the mechanism of these phenomena. Hence I shall have to refer to them frequently, although protoplasm is certainly a truly colloidal system containing very much smaller particles.

The other limiting case is that of dilatancy. So far, it has been investigated only in coarse suspensions. Although observed and named by Osborne Reynolds¹⁷ in 1885, it has only recently been recognized as a remarkable counterpart to thixotropy. Osborne Reynolds used the term when describing the behavior of moist quartz sand: It whitens and appears to be dry when the foot falls on it and becomes wet again when the foot is raised. An aqueous suspension of finely ground quartz powder (particle size 1 to 5 μ) at a concentration of about 44 per cent of the solid is strongly dilatant³: A glass rod can easily be moved through the mass at low speed, but an enormous resistance is set up if the speed is increased above a certain limit. Using the viscometer mentioned above, curve 3 (cf. Fig. 1) is observed: The suspension behaves like a Newtonian liquid at low speeds but, from a certain higher speed, the horizontal part of the curve implies a solid behavior. In this part of the curve there are some intricacies which are better discussed later. Suspensions of intact starch grains in water are strongly dilatant too.³

There is every reason to believe that colloidal solutions may also be dilatant. A colloidal solution of silicic acid of a suitable concentration and pH is found to be extremely viscous but Newtonian in its behavior; it becomes hard and brittle, breaking up to a white,

dry powder when crushed with a stout glass rod. Left to itself, the powdered mass returns again to its original viscous liquid state.¹⁵ A technical product, Nuodex Calcium-S (a colloidal solution of about 10 per cent calcium naphthenate in a petroleum distillate), shows a similar behavior.¹⁵ A complete curve of one of these colloidal systems corresponding to curve 3 in Figure 1 has not yet been measured.

The behavior of coarse particles of suspensions under the microscope gives us a clue concerning that property of the particles which makes a suspension dilatant or thixotropic.^{16, 19} The particles of a dilatant suspension are quite independent of each other; there is not the least indication of coagulation. If they are settled on the slide, they are all separated from each other; if dislodged and driven into the liquid by a slight knock, they remain separated in Brownian movement until they have settled again. On the other hand, the particles of a thixotropic suspension are always found to be coagulated to a certain degree, sticking together and forming clusters. If brought into suspension in the liquid, they may be temporarily separated from each other, but they always unite again to clusters.

This distinctive behavior allows us to understand many results obtained with thixotropic or dilatant systems. For instance, in order to make a concentrated iron oxide sol thixotropic a small amount of a coagulating electrolyte like NaCl must be added, an amount much smaller than that needed for actual coagulation.²⁰ In agreement with the positive ζ -potential of the iron oxide particles and with the Schulze-Hardy rule, the anions are especially effective. Smaller concentrations of polyvalent anions are necessary to obtain the same state of thixotropy, which is characterized by the same time of re-solidification to a gel after the original gel has been liquefied to a sol by shaking. The thixotropic state, therefore, is often considered to be a primary stage of coagulation.

The following experiments done by W. Heller prove this concept more quantitatively²¹: If an iron oxide sol, which is just too dilute in iron oxide to give a thixotropic gel on adding a certain amount of electrolyte, is centrifuged after the electrolyte has been added, a more concentrated, gelatinous sediment is accumulated at the bottom of the vessel. This sediment is not formed on using the same centrifugal force, if no electrolyte has been added. The sediment can be reversibly redispersed in the liquid by shaking. If the sediment is separated from the less concentrated liquid on top, it is found to be a normal, i. e., reversible, thixotropic gel. From the

way the rate of sedimentation is correlated with the concentration of the added electrolyte, it can be concluded that reversible coagulates are formed. These are very rich in water and contain a number of colloidal iron oxide particles. This number increases greatly with increasing concentration of the added electrolyte. Such reversible coagulates, "geloids," are also formed in the original dilute sol on adding electrolyte, but their concentration is not high enough to let them coalesce to a coherent structure and turn the whole sol to a gel. If, however, the geloids are concentrated by centrifuging, they coalesce to a thixotropic gel. By investigating the change of so-called conservative light absorption during the process of thixotropic gelation, i. e., the light absorption caused exclusively by the scattering of light (due to the presence of the colloidal particles), it can be shown that the reversible coagulation causing thixotropy is always accompanied by a certain degree of irreversible coagulation, which increases strongly with increasing electrolyte concentration.²² This irreversible coagulation is the chief factor in the regular coagulation occurring at higher concentrations of electrolyte.

How many colloidal particles are contained in a geloid and how their number depends on the nature of the colloid is not known. These differences may be marked, as can be concluded from the fact that the minimum concentrations of colloid, when a thixotropic gel is formed, vary distinctly: For an iron oxide sol (of the Graham type), this concentration is about 5 gm. per litre,²³ for a V_2O_5 sol, it is only about 0.1 gm. per litre.²⁴

Thixotropy may be sensitive to very small changes in the concentration of substances contained in the sol. Thus iron oxide sols are particularly sensitive to H^+ and OH^- ions⁷; the time of solidification is strongly increased by an increase in H^+ ions, decreased by an increase in OH^- ions, i. e., an increase in H^+ ions has a liquefying effect and vice versa.²⁵ A pH change from 3.9 to 3.1 caused the time of solidification to rise from 82 seconds to 150 minutes. By dipping a silver plate into an iron oxide gel for 18 hours, the pH changed from 3.4 to 3.8, producing a decrease in the time of solidification from 33 minutes to 72 seconds. It was further found that amino acids had a liquefying action upon these gels, independent of the change they caused in pH, i. e., they increased the time of solidification, although they increased the pH.²⁰

It is important, also, from a biological point of view, that not only electrolytes, but also suitable organic nonelectrolytes, are able

to produce thixotropy. Alcohol added to a suitable iron oxide sol makes it thixotropic.²⁵ We are probably dealing with a coagulation due to "dehydration." These iron oxide sols may be considered to be sufficiently hydrophilic to allow one to expect such effects of dehydration as are discussed by Kruyt and Bungenberg de Jong in their theory of the stability of hydrophilic sols and of coacervation.²⁶ If the alcohol is removed from the thixotropic gel by exposing it to sulfuric acid in a desiccator, the gel is liquefied to a sol.

All these results show that substances causing a certain degree of coagulation lead to the formation of thixotropic systems. Inversely, a strong peptizing agent, making the particles independent of each other, can transform a thixotropic system (having the proper particle size) into a dilatant one. A technical dispersing agent, "Hornkem," a sulfonated product of vegetable origin, applied in a suitably high concentration in aqueous solution, acts upon ZnO particles in such a way that it produces a strongly dilatant suspension parallel with a maximum degree of dispersion.²⁷ In pure water, the same ZnO produces a very stiff paste without any indication of dilatancy. In this case it can even be observed that thixotropy requires a medium degree of coagulation: In pure water the degree of clustering is too great to allow a thixotropic behavior of the suspension; if, however, the right amount of a dilute solution of Hornkem is added, the paste becomes thixotropic, whereas at higher concentrations of Hornkem a state of high dispersion and dilatancy is reached.²⁷

It fits in well with these results that a dilatant paste can be transformed into a thixotropic one by causing a certain degree of coagulation of the particles. Hydrophilic colloids at low concentrations favor the coagulation of hydrophobic particles, the phenomenon of sensitization; whereas at high concentration they protect the hydrophobic system. In this way, lecithin at low concentration may coagulate aqueous quartz suspensions to a certain degree²⁸; this is proved by the marked increase in the rate of sedimentation of the clustered particles after lecithin has been added. Only in this range of sensitization by the lecithin are these quartz suspensions found to be thixotropic, whereas they are dilatant in pure water.

The following facts cannot, presumably, be applied to biological phenomena, but they deserve to be mentioned briefly, nevertheless. The thixotropic or dilatant state depends strongly on the dispersion medium. Whereas suspensions of quartz or of intact starch grains

are dilatant in water, they are thixotropic in organic liquids such as benzene, carbon tetrachloride, etc.³ It is possible to pass gradually from one state to the other by using two miscible liquids.

In these organic liquids, too, a small amount of a second substance may cause a marked change in behavior: A paste made from a very fine iron powder and carbon tetrachloride is pronouncedly plastic, a behavior which is practically always correlated with a marked thixotropy.²⁹ On adding a small amount of oleic acid, the paste is liquefied to a strongly dilatant suspension. The adsorption of the oleic acid on the surface of the particles produces a state of independence, and hence dilatancy.

Suspensions of finely powdered solids in organic liquids, such as mixtures of oils, have been used for a very long time as paints. It is, therefore, no wonder that painters have been acquainted with the manifold, anomalous mechanical properties of suspensions, though without having defined such limiting cases as thixotropy and dilatancy. But it can hardly be doubted that many pastes of paints, described as stiff and plastic and as having a marked yield value, are thixotropic (in our terminology) if the concentration of the solid is suitably chosen, whereas if they were dispersed to a mobile liquid by the right dispersing agent, they would show dilatancy, again at a suitable concentration of the solid. Green,¹⁶ at a time when the phenomenon of thixotropy was hardly known, published striking photomicrographs of plastic pastes of ZnO formed by suspension in kerosene, which showed the ZnO particles to be coagulated. When poppy seed oil was added as a dispersing agent, the same particles were independent and dispersed. They are shown in Figures 2a and 2b and are good examples of the state of the particles in a thixotropic and in a dilatant system.

Our knowledge of the forces acting between the particles and causing these phenomena is not yet sufficiently advanced to allow me to state concisely, in the compass of a lecture, the processes involved. Only a few points may be mentioned. The geloids in thixotropic sols and gels are closely related to the tactoids,¹⁹ i. e., double refracting groups of oriented particles formed spontaneously in concentrated sols containing nonspherical particles,³⁰ and to the coacervates as defined by Bungenberg de Jong,²⁶ i. e., liquid coagulates of hydrophilic sols containing one or more kinds of colloidal particles. In geloids, tactoids, and coacervates, the colloidal particles are very far apart,³¹ up to many μ . It is, therefore, improbable that the attraction between the particles is due to van der Waals' forces,

which act over smaller distances; an attraction due to electric forces is more probable. The possibility has been considered that both attractive and repulsive forces between the particles may be of electric origin.³² But this concept is perhaps not easily reconciled with the fact that the forces between the particles may be markedly specific. Vanadium pentoxide, as well as benzopurpurin sols, form tactoids which carry a negative electric charge. In a mixed sol of the two, under proper conditions, both kinds of tactoids may be formed

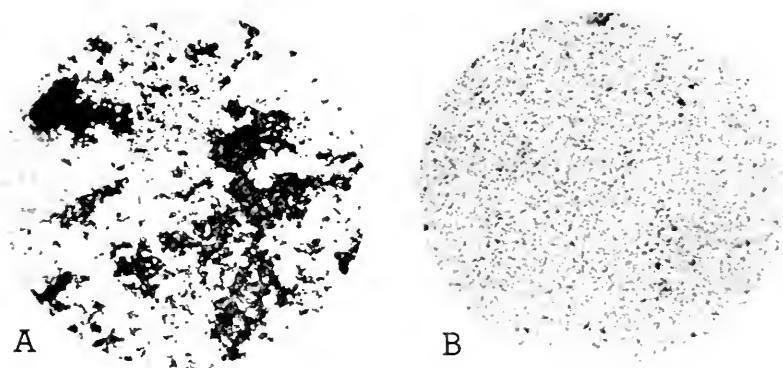

FIG. 2.

side by side, containing only V_2O_5 and benzopurpurin particles respectively.³³ These two kinds of tactoids can be distinguished, because those of V_2O_5 are positively, those of the dyestuff negatively, double refracting. The very specific behavior of some ions when producing auto-complex coacervates must also be mentioned in this connection.

The nonspherical shape of the colloidal particles strongly favors thixotropy. But the opinion, which has been occasionally expressed, that nonspherical shape is an indispensable factor for thixotropy is not correct. Thixotropic systems are known whose particles hardly deviate from the spherical shape, e. g., pastes of intact starch grains in organic liquids.³

It is becoming more and more probable³⁴ that the thixotropic, i. e., isothermal change, $\text{sol} \rightleftharpoons \text{gel}$, is the general phenomenon. When dealing with the so-called, nonisothermal $\text{sol} \rightleftharpoons \text{gel}$ transformation, as we have it in aqueous sols of gelatin, agar, or methyl cellulose,³⁵ we must distinguish between (1) the actual $\text{sol} \rightleftharpoons \text{gel}$ transforma-

tion, which presumably has the same mechanism as the thixotropic transformation and which is not changed essentially by a change of temperature, and (2) a change in the solvation of the particles, which depends pronouncedly on temperature.³⁵ The latter factor may secondarily influence the sol \rightleftharpoons gel change. Gelatin and agar have the normal behavior—the gel is formed at low temperatures, the sol at higher ones—whereas sols of methyl cellulose show the so-called inverse, nonisothermal sol \rightleftharpoons gel transformation: The gel is produced at higher temperatures and turns to a sol again on being cooled.

The problems of thixotropy are always those of a special kind of coagulation. Dilatancy is observed when the particles have a very small, or perhaps even the least possible, tendency to be coagulated, i. e., they do not stick spontaneously to each other at all. As long as the suspension is exposed to weak mechanical forces, the particles glide easily past each other, thanks to the continuous layers of liquid between them. But if the forces applied exceed a certain limit, the particles are brought much closer together. This may lead to a displacement of the layer causing the independence of the particles—the layer of oleic acid in the case of the iron particles, or the electric double layer in aqueous suspensions—and the particles may be made to touch each other. This will cause a high resistance toward the acting force. As soon as the force stops acting, the particles return to their independent behavior, which corresponds to a state of equilibrium, and the suspension again assumes its liquid state.³

We do not yet know whether thixotropy and dilatancy are always produced by the same kind of mechanism or whether one will have to distinguish different types of these phenomena in the future. These do not represent the only characteristic features of anomalous viscosity in colloidal solutions and in suspensions. One other phenomenon may be mentioned, because it has been confused with dilatancy.

Gels of V_2O_5 and of bentonite, suspensions of clays, etc., are liquefied by strong shaking and stirring, but a weak movement—a tapping or rolling of the vessel containing the liquefied system—may markedly increase the rate of setting to a solid gel or paste. This phenomenon has been called rheopexy.³⁶ Striking experiments were done by Hauser and Reed³⁷ with aqueous bentonite sols; these sols were fairly homodisperse, the particle diameter of the finest dispersion being about 15 $m\mu$ (a), that of the coarsest 35 $m\mu$ (b). The times of normal thixotropic setting were 42 seconds and 70 minutes

for a and b respectively. The rheopectic effect was produced by grasping the tube containing the sol between two fingers and oscillating it like a pendulum about the point where it was grasped. The times of rheopectic setting were about 10 seconds and 40 seconds for a and b respectively. In rheopecty, the nonspherical shape seems to be a decisive factor in causing the phenomenon. The gel (or paste) produced by rheopectic action does not appear to have the same structure as the one that has set spontaneously. The difference between dilatancy and rheopecty is obvious: In dilatancy the final state is liquid; the system behaves as a solid only as long as the external force is acting. In rheopecty the final state is solid; the external force, causing the slight movement, only increases the rate of solidification.

The mechanical forces causing liquefaction in thixotropy and the increased rate of solidification in rheopecty may be replaced by the action of ultrasonic waves.^{38, 39} These phenomena deserve to be discussed here, because the action of ultrasonics upon organisms has already produced some interesting results and may lead to a better discrimination of the manifold influence of mechanical forces upon living systems.^{39a}

Thixotropic gels like those of iron oxide, etc., are liquefied by ultrasonics of sufficiently high energy.³⁸ Experiments of this kind are done by simply dipping the test tube containing the gel into the oil fountain that is formed above the vibrating quartz plate generating the ultrasonic waves; the plate is lying in an oil bath. This effect is one of so-called cavitation.⁴⁰ The waves produce periodic dilations and compressions in the systems through which they pass. The dilations may be intense enough to cause the liquid to tear, i. e., a cavity is formed, filled with the vapor of the liquid. This cavity may collapse, if it again gets into a region of higher pressure. This collapse of a cavity—to which we are referring if we speak of an effect of cavitation—may lead to very high local concentrations of energy and hence to effects like those of an explosion. It is apparently mainly this phenomenon that produces the strongly destructive effects of ultrasonics.⁴⁰ Cavitation is, for instance, the cause of the strong dispersing action of ultrasonics upon mixtures of organic liquids, such as benzene and water, where it has been investigated thoroughly. A collapse of cavities does not occur in vacuo, the cavities formed simply increase in size; under a sufficiently high outside pressure, on the other hand, cavities are not formed at all.⁴⁰ Hence, an action of ultrasonics due to cavitation is observed only

in a certain range of pressures and it may, therefore, be distinguished from other actions of the waves not caused by cavitation. In vacuo and at a suitably high pressure, thixotropic gels are not liquefied by ultrasonics, which proves that the phenomenon is produced by a collapse of cavities.⁴¹

The thixotropic decrease of structural viscosity in concentrated colloidal solutions can also be produced by ultrasonics as an effect of cavitation. This was shown for sols of gelatin where the effect was partially reversible.⁴² In many cases effects are observed which are due to cavitation, but are irreversible and which, therefore, must be explained somewhat differently. In the sols of methyl cellulose mentioned above, the structural viscosity left over, after cooling a gel which had been formed at higher temperatures, can be made to disappear by ultrasonics.⁴³ In colloidal solutions of hemocyanin (*Helix pomatia*), ultrasonics split the molecules in halves; on prolonged action, a certain percentage of eighths appears.⁴⁴ Perhaps such a splitting effect occurs to a smaller or larger extent in many solutions of highly polymerized organic substances.⁴²

Besides the destructive action due to cavitation, ultrasonics also exert a coagulating effect which becomes conspicuous, both at high energies and at such low ones that no more effects of cavitation are observed.⁴⁵ Coagulation is very striking when ultrasonics act upon fogs or smokes.⁴⁶ It is also shown by the fact that, on emulsifying two liquids like water and benzene in each other, a limiting value of particle concentration is reached, where the dispersing effect is balanced by the coagulation.⁴⁵ In emulsions and suspensions of suitable concentration, stationary ultrasonic waves cause an accumulation of the particles in the nodes or antinodes, depending on whether the particles are lighter or heavier than the surrounding medium.⁴⁵ Coagulation may be observed where this accumulation takes place. Coagulation by ultrasonics may be due to several reasons which are not easily distinguished from each other. Two may be mentioned: (1) Attractive forces of a hydrodynamic nature are produced between particles, if the particles are suspended in a medium exposed to vibration.⁴⁷ (2) The so-called orthokinetic coagulation may cause collisions and hence a clustering of particles.⁴⁸ This latter kind of coagulation occurs if the particles do not have equal sizes and hence move with different rates, when exposed to external forces.

The marked effect of ultrasonics on some rheopectic suspensions is due to coagulation. If a suspension of a kaolin ("Stockalite") in an aqueous solution of NaCl was liquefied by shaking and exposed

to ultrasonics, which were too weak to cause cavitation but strong enough to cause coagulation, it solidified in 15 seconds, whereas it remained liquid for 17 minutes if left to itself; it took 30 seconds to cause the rheopectic solidification by tapping.³⁹ A dilatant suspension is kept liquid by ultrasonics; it does not show the characteristic increase in mechanical resistance, when treated with a glass rod.³⁹ This effect is not due to cavitation.

Finally, there is still a third effect, which appears with very weak ultrasonics: Rod- or plate-like particles of a suspension are oriented with their long axes vertical to the direction in which the energy of the waves flows.³⁹

FOOTNOTES

¹ Verworn, M., *Allgemeine Physiologie*, Jena, (1895); Wilson, E. B., *The Cell in Development and Inheritance*, New York, (1897).

² For a general survey of thixotropy, see H. Freundlich, *Thixotropy, Actualités scientifiques et industrielles*, No. 267, Paris, Hermann et Cie., (1935).

³ Freundlich, H., and Röder, H. L., *Trans. Farad. Soc.*, 1938, 34, 308; Röder, H. L., *Rheology of Suspensions*, Ph. D. Thesis, Amsterdam, 1939.

⁴ Sameshima, I., *Bl. chem. Soc.*, Japan, 1926, 1, 255.

⁵ Laing, M. E., *Jour. Phys. Chem.*, 1924, 28, 673.

⁶ Freundlich, H., and Seifriz, W., *Z. phys. Chem.*, 1923, 104, 233.

⁷ Szegvari, A., and Schalek, E., *Kolloid-Z.*, 1925, 32, 318; 33, 326; and many later articles, mostly by Freundlich and co-workers; for references, see Freundlich, H., *Kolloid-Z.*, 1928, 46, 289, and Freundlich, H., *Thixotropy*, 1935 (see footnote 2).

⁸ Freundlich, H., Schmidt, O., and Lindau, G., *Z. phys. Chem., Bodensteinfestband* 1931, 333; *Kolloid Beihefte*, 1932, 36, 43; Hauser, E. A., and Reed, C. E., *Jour. Phys. Chem.*, 1937, 41, 911.

⁹ Edsall, J. T., and Mehl, J. W., *Jour. Biol. Chem.*, 1940, 133, 409; Mirsky, A. E., *Cold Spring Harbor Symposia on Quantitative Biology*, 1938, 6, 150.

¹⁰ Lauffer, A. M., and Stanley, W. M., *Kolloid-Z.*, 1940, 91, 62 (no mention is made in this paper of thixotropy, but there is anomalous viscosity).

¹¹ Zocher, H., and Albu, H. W., *Kolloid-Z.*, 1928, 46, 27.

¹² Zocher, H., and Albu, H. W., *Kolloid-Z.*, 1928, 46, 33.

¹³ Freundlich, H., and Abramson, H. A., *Z. phys. Chem.*, 1927, 131, 278; Heller, W., *Compt. rend.*, 1936, 202, 1507.

¹⁴ Freundlich, H., and Juliusburger, F., *Trans. Farad. Soc.*, 1934, 30, 333; Freundlich, H., and Jones, A. D., *Jour. phys. Chem.*, 1936, 40, 1217.

¹⁵ Recklinghausen, H. V., *Kolloid-Z.*, 1932, 60, 34.

¹⁶ Green, H., *Ind. and Eng. Chem.*, 1923, 15, 122.

¹⁷ Reynolds, O., *Phil. Mag.* (5), 1885, 20, 469; *Nature*, 1886, 33, 429.

¹⁸ Olze, A., and Daniel, F. K. quoted by Freundlich, H., and Röder, H. L., *Trans. Farad. Soc.*, 1938, 34, 308.

¹⁹ Freundlich, H., and Jones, A. D., *Jour. Phys. Chem.*, 1936, 40, 1217.

²⁰ Freundlich, H., and Söllner, K., *Kolloid-Z.*, 1928, 45, 348.

²¹ Heller, W., *Compt. rend.*, 1936, 202, 61; *Jour. Phys. Chem.*, in press.

²² Heller, W., and Quimfe, G., *Compt. rend.*, 1937, 205, 857; Heller, W., and Vassy, E., *Compt. rend.*, 1939, 208, 812, *Jour. phys. Chem.*, in press.

- ²² Kandeiaiky, B. S., *Kolloid-Z.*, 1936, 74, 200.
- ²³ Goodeve, C. F., *Trans. Farad. Soc.*, 1939, 35, 342.
- ²⁴ Freundlich, H., and Söllner, K., *Kolloid-Z.*, 1928, 44, 309.
- ²⁵ See, e.g., Bungenberg de Jong, H. G., *La coacervation, les coacervats, et leur importance en biologie*, Volumes 1 and 2, Paris, Hermann et Cie., 1936.
- ²⁶ Daniel, F. K., *India Rubber World*, 101, Nos. 3 and 4, 1939.
- ²⁷ Freundlich, H., *Jour. Soc. Chem. Ind.*, 1934, 53, 223 T., and especially Southorn, W. A., Ph. D. Thesis, London, 1939.
- ²⁸ Verwey, E. J., and de Boer, J. H., *Rec. trav. chim.*, 1938, 57, 383.
- ²⁹ As to the nature of tactoids, see: Zocher, H., *Z. anorgan. u. allg. Chem.*, 1925, 147, 91; Coper, K., and Freundlich, H., *Trans. Farad. Soc.*, 1937, 33, 348; Heller, W., *Compt. rend.*, 1935, 201, 831.
- ³⁰ Heller, W., unpublished.
- ³¹ Levine, S., *Proc. Roy. Soc. London*, (Series A), 1939, 170, 145, 165; Levine, S., and Dube, S. P., *Trans. Farad. Soc.*, 1939, 35, 1125, 1141.
- ³² Freundlich, H., Enslin, O., and Söllner, K., *Protoplasma*, 1933, 17, 489.
- ³³ Röder, H. L., *Rheology of suspensions, A study of dilatancy and thixotropy*, Ph. D. Thesis, Amsterdam 1939; Heller, W., *Compt. rend.*, 1938, 207, 157.
- ³⁴ Heymann, E., *Trans. Farad. Soc.*, 1935, 31, 846; 1936, 32, 1.
- ³⁵ Freundlich, H., and Juliusburger, F., *Trans. Farad. Soc.*, 1935, 31, 920.
- ³⁶ Hauser, E. A., and Reed, C. E., *Jour. Phys. Chem.*, 1937, 41, 911.
- ³⁷ Freundlich, H., *Kapillarchemie*, Leipzig, 4th ed., vol. 2, 1932, 616; Freundlich, H., Rogowski, F., and Söllner, K., *Z. phys. Chem.*, A., 1932, 160, 469; *Kolloid Beihfte*, 1933, 37, 223; Freundlich, H., and Söllner, K., *Trans. Farad. Soc.*, 1936, 32, 966.
- ³⁸ Burger, F. J., and Söllner, K., *Trans. Farad. Soc.*, 1936, 32, 1598.
- ^{39a} Some newer reviews of the action of ultrasonics on biological objects are: Dognon, A. and Biancani, E. H., *Ultra-Sons et Biologie*, Paris, Gauthier-Villards, 1937; Hiedemann, E., *Grundlagen und Ergebnisse der Ultraschallforschung*, Berlin, Walter de Gruyter and Co., 1939, pp. 179-185.
- ⁴⁰ See, e. g., Bondy, C., and Söllner, K., *Trans. Farad. Soc.*, 1935, 31, 835; Söllner, K., *Jour. Phys. Chem.*, 1938, 42, 1071.
- ⁴¹ Freundlich, H., and Söllner, K., *Trans. Farad. Soc.*, 1936, 32, 966.
- ⁴² Freundlich, H., and Gillings, D. W., *Trans. Farad. Soc.*, 1938, 34, 649. See there many additional references.
- ⁴³ Heymann, E., *Trans. Farad. Soc.*, 1935, 31, 846.
- ⁴⁴ Brohult, S., *Nature*, 1937, 140, 805.
- ⁴⁵ Söllner, K., and Bondy, C., *Trans. Farad. Soc.*, 1936, 32, 616.
- ⁴⁶ Patterson, H. S., and Cawood, W., *Nature*, 1931, 127, 667; Brandt, O., and Hiedemann, E., *Trans. Farad. Soc.*, 1936, 32, 1101; *Kolloid-Z.*, 1936, 75, 129; Brandt, O., Freund, H., and Hiedemann, E., *Kolloid-Z.* 1936, 77, 103; da C. Andrade, E. N., *Trans. Farad. Soc.*, 1936, 32, 1111; etc. The best summary in: Hiedemann, E., *Grundlagen und Ergebnisse der Ultraschallforschung*, Berlin, 1939.
- ⁴⁷ Bjercknes, V., *Vorlesungen über hydrodynamische Fernkräfte nach C. A. Bjercknes' Theorie*, Leipzig, 1900-01; König, W., *Ann. Phys.* (Wiedemann), 1891, 42, 353, 549. Brandt, O., Freund, H., and Hiedemann, E., *Kolloid-Z.*, 1936, 77, 103; *Zeitschr. f. Physik*, 1937, 104, 511; etc.
- ⁴⁸ Söllner, K., and Bondy, C., l. c. 45; Söllner, K., *Trans. Farad. Soc.*, 1936, 32, 1119; Brandt, O., and Hiedemann, E., and Brandt, O., Freund H., and Hiedemann, E., l. c. 46; for a review see pp. 199-201 in Hiedemann, E., *Grundlagen und Ergebnisse der Ultraschallforschung*, Berlin, 1939.



STRUCTURAL DIFFERENTIATION OF CYTOPLASM

G. W. SCARTH

McGill University

Theories as to the basic structure of protoplasm usually assume that there is a single master key to the problem. But if differentiation exists in the physical properties of different regions of the cell, it is necessary to consider the question of corresponding differences in submicroscopic structure. The present paper is concerned with the cytoplasm and, because of considerations of time and relative importance, will deal only with the continuous ground substance, omitting the various inclusions.

The type of cytoplasmic differentiation which seems to be most general is that of a series of concentric zones, not usually defined by any sharp visible boundary but each showing distinctive physical properties when studied experimentally.

INTERIOR VS. CORTEX

As regards animal cells, viscosity tests of all kinds agree in proving that the bulk of the internal cytoplasm of echinoderm eggs and sometimes of amoeba and other protozoa is relatively fluid. The same seems to be the case with most kinds of animal cells though there appear to be exceptions such as epidermal and certain other epithelial cells. Along with the usual fluidity of the interior, its water miscibility, solvent properties, and electrical conductivity point to its being a sol with aqueous dispersion medium.

On the other hand, a cortical zone of varying thickness always has much higher consistency. This region combines elastic with plastic or fluid qualities to a degree which is rarely if ever paralleled in physical systems; the combination becomes more intelligible in the light of its marked capacity for undergoing rapid reversible gel-sol transformation. In amoeboid and other movements involving vortical streaming, not only do reciprocal sol-gel changes occur but the cytoplasm circulates between the internal and cortical regions. However, the whole of the cortex does not liquify at once: some coherent structure persists as a basis of organization.

As regards plant cells it was through the investigations of my co-workers, Siminovitch and Levitt, on cytoplasmic behavior in relation to frost resistance that the widespread occurrence in such cells of the same differentiation into gelatinous cortex and liquid endoplasm or mesoplasm was impressed upon me. In a non-vacuolate type, the pollen mother cells of *Trillium*, an outer plasmagel zone of variable thickness and an inner fluid one are easily demonstrated with the aid of a little micromanipulation (Stern). In vacuolate cells having a thick layer of cytoplasm, such as the cortical cells of many trees especially in winter time, the same distinction is apparent when rupture occurs during deplasmolysis. A thin cortical layer tears the rest spills out and mixes with water. Even in the thinnest cytoplasmic layers, this differentiation is revealed by a technique based on Chambers' method of applying oil drops to the cell surface. An oil drop snaps into the surface of a plant protoplast, taking the form of a biconvex lens. When the protoplast is stretched (by deplasmolysis or pressure) the oil drop is pulled out into a flatter and ultimately concavo-convex shape. When again the protoplast is allowed to contract, the oil goes through reverse change in shape, and if the contraction goes far enough it becomes spherical. Evidently the tension on the edge of the oil lens is that of an elastic, not a liquid, film. But while the cortex is thus shown to shrink and stretch elastically, the mesoplasm flows into and out of the angular space between the edge of the drop and the surface of the vacuole, and must therefore be quite fluid (Siminovitch and Levitt).

PROTOPLASMIC SURFACE FILM OR ECTOPLAST

The cortical gel layer, when wide enough to be seen, often shows little optical differentiation from the liquid endoplasm except as regards restriction of Brownian movement. Both zones are commonly granular. In contrast to this there is distinguishable on the surface of many cells a thin layer of more hyaline appearance. This has been called ectoplasm or the ectoplast, but as the term has also been applied to the cortical gel in amoeba, Chambers prefers to call it the "protoplasmic surface film." Much of our knowledge of this layer comes from Chambers' studies of echinoderm eggs. He gives many proofs of its fluidity and shows that its continuity over the surface is essential to the integrity of the protoplast, whereas other membranes which normally exist external to

this can be removed without harm to the cell. The hyaline film on amoeba is also fluid and cohesive. According to Mast the fluid film is here bounded by a more rigid pellicle, the plasmalemma.

In the case of plant cells a so-called hyaline layer on the surface becomes visibly apparent only in very fine strands pulled out from the surface. Incidentally, though it has been the custom to call the film hyaline, it is by no means free from granules. But the very fact that strands of fluid consistency *can* be pulled out from the surface of a cell which has been dehydrated by plasmolysis until its gel layer is rigid and brittle, is evidence for the existence of a differentiated liquid layer overlying the gel. The fine strands which connect a plasmolysed plant protoplast with the cell wall, being composed entirely of the film substance, reveal some of its properties by their behavior. In strong plasmolytes they stiffen sufficiently to crumple up on breaking, but tenuous as they are, this stiffening seems to be confined to a still thinner surface film, since under the same conditions of dehydration they become beaded on standing due apparently to the running into drops of a more liquid core. All this indicates that the protoplasmic surface layer may have a denser film of its own—compare the plasmalemma of amoeba. In spite of this capacity for hardening at its surface, the ectoplast shows little sign of *elastic* extensibility. That quality of the protoplasm seems to reside mainly in the layer beneath.

Some properties of the surface film in plant cells are brought out by the behavior of applied oil drops. On making contact with the protoplasmic surface, a body of oil, even when large, relative to the cell, immediately has its surface tension greatly reduced so that it will often maintain shapes of nonminimal area. That the surface-active material spreads as a film over the oil is shown by the speed with which the change occurs and by the dragging of granules and chloroplasts with it, especially when the oil drop is large. Further, the transport of these bodies through the cytoplasm to the drop seems to prove bodily movement of a film over the protoplasm. The movement of the film is not prevented by plasmolysis which is strong enough to make the gel layer quite stiff, which is further proof that the surface film is distinct from the gel layer.

THE TONOPLAST

At the inner cytoplasmic surface in contact with the central vacuole is another film, the tonoplast of de Vries, which is often

left intact when the rest of the cytoplasm has become disorganized and separated from it. The isolated tonoplast persists as a fluid semipermeable sac enclosing the vacuolar sap, and may preserve its integrity for days or even weeks. By contrast, the external surface film has never been completely separated from the protoplast, but probably this is due simply to its position, as local elevation sometimes occurs naturally and may be produced artificially. Both surfaces of the tonoplast resemble the surface of the ectoplast in showing immediate adhesion to oil but adhesion to glass only after mechanical disturbance. An oil drop which has snapped onto the outer surface of a freed tonoplast is deformed somewhat by stretching of the latter but not to the same extent as at the cell surface. It is possible that this slight display of elastic property may be due to an adsorbed film of protein from the endoplasm. Chambers and Höfler emphasize the highly fluid, though cohesive and extensible, nature of the tonoplast and the immiscibility of its substance with water.

On the whole the physical properties of the tonoplast and ectoplast seem to be very similar, and Plowe has described how the two films may merge to form a single envelope.

IS THERE AN INNER GEL LAYER?

Since the cytoplasm of the plant cell is bounded on its vacuolar side by a fluid layer similar to the surface film, the question arises whether there is also an inner zone which corresponds to the cortical plasmagel. The frequent elasticity of transvacuolar strands and of strands pulled by micro-needles into the vacuole, as compared with the relatively inelastic quality of strands pulled from an isolated tonoplast, suggests that the elasticity of the former resides in the core of endoplasm which such strands usually contain. On the other hand, an oil drop applied to the surface of the vacuole sinks into the cytoplasm much more easily than a similar drop applied to the outside, which indicates that if an inner gel layer exists it is much less substantial than the outer one.

OTHER CYTOPLASMIC FILMS OR MEMBRANES

It seems reasonable to regard the colorless film which covers chloroplasts and can be elevated from them in pathological swelling as being equally with the ectoplast and tonoplast a cytoplasmic structure. Even the nuclear membrane, or part of it at least (since

in elevation it sometimes splits into two), may belong to the cytoplasm. All these films show many points of resemblance, among which is their relationship to the kinoplasm.

KINOPLASM

This is a structure of more variable occurrence than those already described, but it seems worthy of mention in a discussion of the fundamental differentiations of cytoplasm because of its possible physiological importance and also because of its apparent relation to the various surface films. Typically the differentiation to which Strasburger gave the name kinoplasm appears as more or less mobile filaments or tubules of very slightly higher refractive index than the matrix in which they are imbedded. To be seen at all, they must be in sharp focus, which may be the reason why they have been observed mainly in plant cells in which the thinness of the cytoplasm keeps them almost in one plane. The chains of granules carried along by the kinoplasm are, however, easily observed.

From the point of view of structure, the visible connection between some of the kinoplasmic strands and the various surface films is of interest. Strands can be seen to flow out of and into the envelope of chloroplasts and of the nucleus. Sometimes they swell to enclose small vacuoles. Streams of kinoplasm have been observed to converge upon an applied oil drop at the moment of contact. This points to a connection between the outer surface film and the strands and also explains how granules and plastids imbedded in the cytoplasm but attached to the kinoplasm come to be carried over the oil drop. It is not possible from a surface view of the cytoplasm to observe at what level the strands lie. In a profile view of the thicker portions of the cytoplasm of some cells, the serial procession of granules which marks the position of a kinoplasmic stream can be located. It ranges from the outer to the inner boundary, and furthermore, streams may arch beyond the general level of the cytoplasm into the central vacuole.

The shapes and movements of kinoplasm recall the typical myelin processes which often adorn the inner surface of the tonoplast and which have also been observed in a number of cases on the outer surface of the ectoplast. It is not suggested that they are identical, since myelin processes proper are random structures and often (though not always) the result of an abnormal environment, whereas

the internal kinoplasm is a normal and presumably functional organization. Yet the tendency of cytoplasmic surface films in general to form these myelin-like outgrowths on both their surfaces, has significance with respect to the composition and molecular structure of both the films and the fibrils.

At this point attention may be drawn to Figure 1, which shows diagrammatically the supposed position and relationship of the differentiations described.

MOLECULAR STRUCTURE

On the basis of physical properties and probable structure, the cytoplasmic differentiations fall into two groups. The plasmasol and plasmagel, being reciprocally transformable, are merely different physical states of one substance. The same relation seems to hold between the films and kinoplasm. But the two pairs show no sign of being interchangeable, and what is more significant, they exhibit fundamentally different properties. Those of the sol-gel region, the endoplasm, include elasticity, thixotropy, stream birefringence, etc., which, as shown by the previous speaker, point to elongated protein units as the building stones. On the other hand, the properties of the film-kinoplasm complex are prominently lipoidal, though no doubt proteins also enter into its composition. Incidentally, while the film substance occupies much the lesser part of the protoplast, yet (if such a distinction can be made) it is the more essential part, being capable of preserving an independent existence for a time, which the endoplasm is unable to do.

Let us see what these lipoidal properties are. Already mentioned is the tendency to myelin formation, a phenomenon confined to a limited group of substances including phosphatides, cerebrocides and trioleates—all ingredients of protoplasm. It depends on the assumption of paracrystalline structure, consisting of parallel sheets of orientated molecules with the principal optical axis and longer diameter of the molecules at right angles to the plane of layering. The type of birefringence which results from this form of structure tends to disappear with a high degree of hydration and reappear on dehydration. Accordingly, it is significant that such double refraction develops in the hyaline layer on the amoebocytes of various invertebrates when partially dehydrated (Fauré-Fremiet, see Schmidt). Masses of myelin-forming material which, under certain conditions, accumulate on the lining of the plant vacuole,

afford confirmatory evidence of their composition by staining with lipid soluble dyes such as chrysoidin and by blackening with osmic acid. These phenomena indicate that the film-forming substance is rich in lipoids as compared with the protoplasm as a whole.

The lamellar type of structure, of which there is optical evidence in myelin figures and in the dehydrated surface film of some cells, is much more highly developed in irreversibly differentiated structures such as chloroplasts and the myelin sheath of nerve. A nerve fiber may be regarded as a sort of crystallized filamentous pseudopodium in which the axon or endoplasm is largely a bundle of parallel protein fibrils and the sheath or ectoplasm consists of concentric sheets of orientated lipid molecules alternating with sheets of protein.

Although it requires exceptional conditions to produce visible double refraction of ordinary protoplasmic films, molecular layering may be present at all times toward their surface where the conditions for orientation operate more strongly. (Contrary to what we might expect, however, the usual lipophilic adhesion of the cell surface would seem to indicate that the hydrocarbon ends of the lipid molecules point outward.) A closely packed, superficial lipid film is, of course, in harmony with the general conception of the protoplasmic surface derived from the study of permeability. The properties of the hypothetical plasma membrane probably belong to an organized film of molecular dimensions (perhaps including proteins as well as lipoids) rather than to the ectoplast as a whole.

As to the colloidal state of the isotropic film substance, its apparent immiscibility with water points to a coacervate rather than a

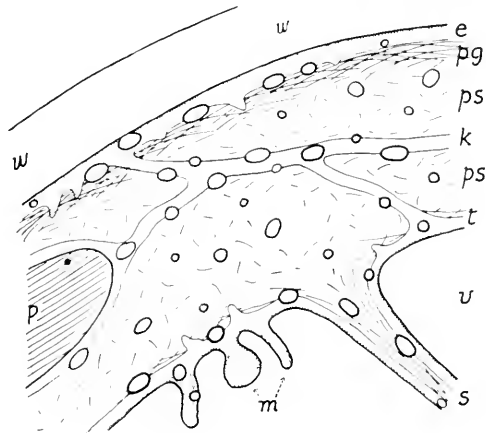

FIG. 1. Diagrammatic cross section of the cytoplasm of a plant cell showing differentiations. w—cell wall. e—ectoplast or protoplasmic surface film. pg—plasmagel layer or cortical endoplasm. k—kinoplasm. t—tonoplast. v—vacuole. s—transvacuolar strand. m—myelin processes. p—plastid.

sol. In a coacervate, according to Bungenberg de Jong, the colloidal units are attracted by electrostatic force but kept apart by that of solvation. Thus the aggregate, while coherent, may be quite fluid. The whole cell has been compared by de Jong to a compound mixed coacervate, but as already pointed out the liquid endoplasm has normally the property of a sol. On the other hand, so-called emulsion structure when it appears in cytoplasm may well be a coacervation phenomenon, and reversible coacervation (droplet precipitation) of colloids in the vacuole is a common occurrence. Compared with this the whole substance of a surface film is suggested to be an irreversible coacervate mass having a very low surface tension.

Of the types of coacervate which have so far been studied extensively by Bungenberg de Jong, those which most resemble the protoplasmic films are the auto-coacervates of phosphatides. Among the points of resemblance are:

relative irreversibility, due apparently to the formation of a stable layer of orientated molecules at their surface;

lipophilic adhesion, due apparently to the hydrocarbon chains of the orientated superficial molecules being directed outward;

myelin formation under certain conditions;

vacuole formation as a result of reduced colloidal hydration (shared by other coacervates) along with *nonfusion of the vacuoles* when pressed together, due apparently to separation by a very stable bimolecular film; and

change from optical isotropy to anisotropy with dehydration.

There is also fair agreement between the action of electrolytes on the packing of phosphatide films and on cell permeability, respectively. On the other hand, their effect on electrophoresis of cells is unlike that of phosphatide drops, inasmuch as the sign of the charge at the cell surface is not so easily reversed. Perhaps further study of coacervates which contain proteins as well as lipoids may furnish still better models of the protoplasmic surface film.

In conclusion, let me point out the moral which my story is meant to teach. It is the fallacy of taking a partial view to be a true picture of the whole. That was the error of the blind men of Indostan in their theorising on the structure of the elephant. I cannot do better than parody this clever fable to suit the present

case. In the original were six blind men. I shall list only four, leaving the reader to complete the number as he sees fit:

It was four fundamentalists to learning much inclined,
Who went to see the Protoplast (though all of them were blind)
That each its structure might observe to satisfy his mind.

The first advancing hurriedly and happening to fall
Right through its soft interior at once began to bawl
"God bless me! But the Protoplast is very like a *sol*."

The second poked the animal and felt his staff repel
Its tough and springy cortex, so he began to yell
" 'Tis evident the Protoplast is very like a *gel*."

The third approaching gingerly did only pinch and squeeze
Its slippery oleaginous hide when he began to wheeze
"It seems to me the Protoplast is just a lump of *grease*."

The fourth man, having punched and probed and proved its plastic state,
Watery yet indissoluble, did thus asseverate
"The Protoplast is a compound, complex *co-a-cerv-ate*."

And so these fundamentalists disputed loud and long
Each in his own opinion exceeding stiff and strong,
Though each was partly in the right and all of them were wrong.

SOME KEY REFERENCES

- BUNGENBERG DE JONG, H. G. (1936) "Actualites Scientifiques et Industrielles." Exposes de Biologie, La Coacervation 6 and 7.
- AND J. BONNER. (1935) "Phosphatide auto-complex coacervates, etc." *Protoplasma* 24, 198.
- CHAMBERS, R. (1938) "The physical state of protoplasm with special reference to its surface." *Amer. Nat.* 72, 141.
- AND K. HÖFLER. (1931) "Micrurgical Studies on the tonoplast of *Allium cepa*." *Protoplasma* 12, 338.
- FREY-WYSSLING, A. (1938) "Submikroskopische morphologie der protoplasmas und seiner derivat." *Protoplasma* monograph.
- PLOWE, J. K. (1931) "Membranes in the plant cell." *Protoplasma* 12, 196.
- SCARTH, G. W. (1927) "Structural organization of protoplasm in the light of Micurgy." *Protoplasma* 2, 189.
- SCARTH, G. W., J. LEVITT, AND D. SIMINOVITCH. (1940) "Plasma membrane structure in the light of frost hardening changes." Cold Spring Harbor symposium 8, 102.
- SIMINOVITCH, D., AND J. LEVITT. (1941) "Relation between frost injury and physical state of protoplasm. ii. The protoplasmic surface." *Can. Jour. of Research*, 19, 9.
- SCHMIDT, W. J. (1937) "Die doppelbrechung von karyoplasma, zytoplasma und metaplasma." *Protoplasma* monograph.



STRUCTURAL DIFFERENTIATION OF THE NUCLEUS

C. L. HUSKINS

McGill University, Montreal

From studies on protoplasm in general, presented by previous speakers in this Symposium, we may proceed to a consideration of the elaborate structural features which are present throughout the life of the nucleus, even in the "resting" stage when many of them are not directly observable. These are today being studied from many different points of view and by very diverse techniques. To simplify, and perhaps to promote, discussion we may classify these attacks upon the problems of the nucleus into four groups, though recognizing, of course, that there are many studies which overlap the boundaries that are, rather arbitrarily, here laid down. Apart from simplifying discussion, the classification may also serve a useful purpose in emphasizing that some studies of the nucleus proceed in rather extraordinary isolation from others and that generalizations made by workers of one group often ignore the data of the other groups or, in some cases, draw unwarranted conclusions from them. The diversity in points of view and of detailed opinion found among students of the nucleus indicate in themselves the complexity of the structures within the boundary of the nuclear membrane and the scope of the problems that remain to be elucidated.

In the first of the four groups we may place all studies aiming at the elucidation of the "submicroscopic" structure of the nucleus. Often such investigations use wave lengths shorter than those of visible light. The second level of analysis comprises all microscopic studies with visible light of killed and fixed materials. The third includes all the varied studies on the living cell made by the methods of "experimental cytology." The fourth comprises the interpretation of structure derived from observations of function made with the techniques of genetics.

Workers in any of these fields should, of course, be familiar with all four. Unfortunately, few of us are! Accepting a more limited standard, those working on the first level *must*, of course, be familiar with the data of the second group. The second group must today know the techniques and discoveries of the geneticists if they are

to avoid drifting again into the relative stagnation from which their subject has fairly recently emerged. The geneticists interested in nuclear structure must know the data of the first and second groups. The third group needs to know all the data of all the groups.

Much of my own work falls jointly into fields two and four. At present I am particularly impressed, perhaps depressed, by the divergencies of opinion between workers on the second level—the one with which I am most familiar. These I consider the greatest source of danger for those workers of the other groups who seek to bolster or check the hypotheses formed from their own observations by the data of the second group. This difficulty in its relation to various aspects of the general problems of nuclear structure will therefore be stressed.

Studies on the presence and distribution of nucleic acids made jointly on the microscopic and submicroscopic levels, have been of particular interest in recent years. The studies with visible light have depended largely on the Feulgen reaction; those at a lower level on the ultraviolet absorption technique developed by Caspersson. With the Feulgen method (the application of Schiff's reagent to the aldehyde groups of the pentose constituents of nucleic acids), desoxyribose (ribodesose-, "thymo-") nucleic acids give a positive staining reaction, while ribose ("yeast-") nucleic acids do not stain. This test is, however, of only limited value in making quantitative determinations of thymonucleic acid in cytological preparations. The method of Caspersson (1936, 1940) permits quantitative determinations of nucleic acids, but the ultraviolet absorption spectra with characteristic maxima at 2,600 Å, "being determined by the nitrogenous constituents," do not differentiate between the desoxyribose and ribose types. For the study of the nucleic acid distribution in the cell, a combination of both methods is thus indicated.

Studies by the Feulgen method have shown clearly that desoxyribonucleic acid is concentrated in the chromosomes and is either absent or present only in very much smaller amounts in the cytoplasm and nucleolus. Since thymonucleic acid appears to be the "typical chromosome nucleic acid" Caspersson (1939) believes that it is synthesized *on* the chromatid. The numerous objections to the use of the Feulgen method in cytology have almost all been adequately dispelled by Milovidov (1938), Hillary (1940), and others who showed that when properly used, "chromatin" and only chromatin is stained by it, as Feulgen claimed. The remaining difficulty, that at certain stages in the maturation of the animal egg the chromo-

somes cannot ordinarily be stained by Feulgen, has recently been removed by Brachet (1940), who finds, contrary to Koltzoff (1938) and others, that the chromosomes are never entirely Feulgen-negative during oögenesis. It is easy to see them throughout all meiotic stages in Triton, and also in many insects, but they tend to disappear at mid-prophase in the frog. Brachet concludes that it is the changing size of the chromosomes and the degree of dispersion of the thymonucleic acid that causes variation in staining capacity. Here is the first of several examples where differences of opinion between workers on the microscopic level can lead to extreme divergence in conclusions about the submicroscopic. Koltzoff, finding no reaction with Feulgen at certain stages, says that thymonucleic acid cannot be an essential component of the gene, but only, perhaps, its protector. Brachet, finding some Feulgen positive particles at all stages, cannot agree.

With his ultraviolet absorption technique Caspersson (1936) showed that: during mitosis nucleic acid is localized in and around the chromosomes, and in collaboration with Hammersten and others, he supplemented the absorption determinations with digestion experiments in which trypsin preparations containing lanthanum dissolve the protein and leave the nucleic acid as insoluble lanthanum thymonucleate. With these two methods it was found that metaphase chromosomes contain nucleic acids and proteins intimately mixed—not as protein islands with surrounding zones rich in nucleic acids—and that salivary gland chromosomes comprise segments alternately rich in and free of nucleic acid. The former are the “bands” so clearly seen after aceto-carmine fixation. Their highly organized structure found after trypsin digestion, indicates that they are more likely to be the seat of the genes than the interband regions which were completely digested.

Mazia and Jaegar (1938) confirmed the trypsin results and performed the complementary experiment of digestion with pepsin. This, they found, “did not dissolve any constituent concerned in maintaining the integrity of the chromosome.” After treatment with spleen nuclease, the chromosomes could not be stained with either aceto-carmine or by the Feulgen method. They had not, however, been disintegrated by the nuclease, as the ninhydrin reaction for determining proteins stained them a deep blue while the cytoplasm stained a lighter blue. These authors conclude that “the chromosome must have a continuous protein structure and the nucleic acid must be attached in such a way that it may be split and the

pentose may be removed without affecting the continuity of structure." Since the protein of the chromosomes was not digested by pepsin, they consider that it may be related to the protamines or histones. The molecular structure of the chromosome which these authors support is one of long polypeptide chains and *parallel* nucleic acid molecules. Experiments with polarized light and X-ray diffraction studies reviewed by Frey-Wyssling (1938) and Schmitt (1940) suggested the assumption of parallel structure and are, like Mazia and Jaegar's data, against earlier concepts of a warp-and-woof fabric.

Caspersson (1936) observed that the nucleic acid content is increased shortly before cell division, and after cell division it decreases again. Later (1939), he showed that in grasshopper spermatocytes, nucleic acid "synthesis" is completed, i. e., the maximum amount is reached, before "maximum condensation of the chromosomes." Since nucleic acids are present in large amounts before cell division and evidence from other studies on the submicroscopic level indicates that the self-reproducing viruses and phages also contain appreciable amounts of nucleic acid in their molecules, an attempt is made to correlate these data with observations from the second level. Here trouble begins—or so at least it seems to me. The generalization is first made that nucleic acid concentration is at a maximum in the nucleus at about the same time as the chromosome is believed to reproduce itself, and from this the conclusion is reached that nucleic acid is fundamentally connected with gene reproduction. This is a plausible and, I should think, even highly probable hypothesis. *But*, how is it supported by microscopic data? The latter deal with *chromosome* reproduction or "splitting," and there is much evidence against and little in favor of the view that this is the same thing as gene reproduction. As Caspersson points out, chromosome "splitting" cannot be seen until there has been an accumulation of nucleic acid, for it is this which stains. He says, for this reason, that the observation of chromosome splitting in very early prophase says nothing against the view that nucleic acid formation and gene reduplication go together. But is it not also reasonable to conclude that the association he has found says nothing definitely for it? In itself the observation that nucleic acid concentration is at a maximum near the time that chromosome splitting becomes obvious may mean nothing more than that nucleic acid concentration permits doubleness of the chromosome to be seen. However this may be, the attempted first and second level correlation runs into further difficulties. The first of these is that descriptive

cytologists, together with cytogeneticists who seek data from irradiation experiments as well as direct observation, fall into two schools regarding the time at which chromosome splitting takes place. And the submicroscopic data that fit in with the views of one school regarding meiosis seem to me to be against that school regarding mitosis. Darlington (1937) and his school consider that meiotic chromosomes reproduce themselves during late pachytene. This fits Caspersson's data on the greatest concentration of nucleic acid occurring just before the tetrad split becomes visible in grasshopper spermatocytes. But Darlington is likewise convinced that reproduction of somatic chromosomes occurs during the resting stage immediately preceding the mitosis in which separation of chromosome halves occurs—his whole "precocity theory" relating meiosis to mitosis stands or falls on this difference in the time of splitting of meiotic and mitotic chromosomes. And during the resting stage, when the chromosomes are believed by this school to split, the nucleic acid concentration of the nucleus is at a minimum! One should add that Darlington and La Cour (1940) state that "the chromosome cycle is adjusted to have a maximum aggregate nucleic acid attachment at metaphase" and that "during the resting stage it is present in the nucleus in smaller quantity and largely unattached to the chromosomes," but the basis for this opinion is not entirely clear. However this may be, the other school, to which I belong, is convinced that chromonemata (and genes) reduplicate themselves at least one and probably two or more cell generations before the mitosis in which the "split" becomes "effective." It is clear from the work of Caspersson and Schultz that nucleic acid production is controlled by genes, but to me the converse conclusion, that nucleic acid is essential to gene reproduction, is not fully established by present data, and it seems most unlikely that the obvious, wide separation of chromosome halves that is seen in the earliest prophase of mitosis is the chronologically immediate result of gene reproduction. Rather, it is related to the onset of mitosis; and the occurrence of polytene chromosomes, apart from all other evidence, shows *per contra* that special physiological conditions not necessarily correlated with gene or chromonema reproduction are involved in the initiation of nuclear division.

Before proceeding to other aspects of Caspersson and Schultz's work we must recall the differentiation of the chromosomes into regions which Heitz (1935) termed "euchromatic" and "heterochromatic." Here we must consider data from all four levels. Long

ago, in the days when it was still commonly believed that the chromosomes lose their identity at the end of mitosis and are formed again in the prophase of the next division, it was noted that in some organisms there are chromatic bodies in the "resting" or "energetic" nucleus. The chromosomes were observed to "form" in connection with these, and they were therefore sometimes called prochromosomes. We cannot enter into any detailed discussion of these in this short talk—for an outline of almost all that is known and of all that can reasonably be guessed on the basis of present knowledge reference may be made to recent publications of Geitler (1938) and White (1940). In brief, the known facts from the second and third levels are: (1) There are parts of the chromosomes that, in many species of animals and plants, stain at all stages of the nuclear cycle. (2) The sex chromosomes are particularly prone to bear such "heterochromatic" regions. (3) Instead of staining at all stages, they may in some species be relatively understained at times when the "euchromatic" parts are deeply stained. (4) Heterochromatic regions are often indiscriminate in their pairing capacity, and (5) the nucleolus is very often formed in connection with one or more of them. From the studies of Caspersson *et al.* we know (6) that they are regions that differ from the rest of the chromosomes in their nucleic acid cycle or total nucleic acid-producing capacity. From the fourth level there may be added (7) that heterochromatic regions seem to be devoid of genes that affect morphological characteristics, and (8) that they affect the expression of genes adjacent to them.

A characteristic that may be related to heterochromatism is the tendency for certain regions of the chromosomes to be understained after exposure to low temperatures. This has been reported in a number of plants, particularly by Shmargon (1938) and other Russian workers, but it is particularly striking in the genera *Paris* and *Trillium* in which Darlington and La Cour (1940) have studied it.¹ These understained "differential regions" of metaphase are, according to Darlington and La Cour, the heterochromatic regions which are deeply stained during the resting stage. They attribute the attenuation at metaphase after cold treatment to relative "nucleic-acid starvation" in these species which, they assume, normally have a particularly high nucleic acid concentration.

Schultz, Caspersson, and Aquilonius (1940) conclude that the heterochromatic regions of *Drosophila melanogaster* have the

¹ See also Wilson & Boothroyd, *Can. J. Res.* 19: 400-412, 1941.

capacity “(1) to form large amounts of thymonucleic acid (or, better perhaps, thymonucleoprotein) in the chromosomes themselves; (2) to form or affect the composition of the nucleoli; (3) to affect the characteristics of neighboring regions translocated to them in such a way as to change the developmental effects of these regions in somatic cells; (4) to affect the content of the ribonucleic acids in the egg cytoplasm of *Drosophila*.” Conclusions (1), (2), and (4) are based largely on ultraviolet data. Number (3) is a conclusion drawn jointly from submicroscopic and genetic data; the problem of the mechanism of the developmental effect, *viz.*, variegation, remains open and need not be entered upon here. Conclusion (4) leads us to the problem of the transfer of materials between the nucleus, nucleolus, and cytoplasm, which will be discussed after we have considered ways of increasing the nucleic acid content of a given nucleus by changing its chromosome constitution.

The old problems of the nucleo-plasma ratio and of changes in nuclear volume began to receive renewed attention following the observations of Jacobj (1935) on differences in nuclear size within a tissue. He found that there were regular differences in size that did not follow the probability curve but one with several maxima. One maximum tended to be about double that of the preceding one, i. e., nuclear volumes of 1 : 2 : 4 : 8 were more frequent than intermediate values. In man almost all tissues were found to have nuclei in nine classes, with volumes ranging from 1–256, which would involve eight doublings. To account for this, Jacobj suggested rhythmic growth, an alternation of longer rest periods and shorter growth periods. Wermel also found a rhythm of nuclear growth in tissue cultures, but showed that the volume doubling was not reached in a single period of growth; the increase was first to one and one-half times. Similar results were obtained in observations on nuclear growth in the intestine of *Anopheles* and in the fat bodies of silkworms (see Wermel and Portugalow, 1935). Fischer (1935) found that growth of the follicular epithelium of some Orthoptera occurs in two ways: (1) by mitotic increase in cell number, during which the nuclei remain in the smallest size class, (2) by increase in cell volume, with constant cell number, which occurs when the secretory function of the cell starts. He states that the secretory cells of the follicle do not divide mitotically at this time but that after the last mitosis there is a doubling of nuclear volume and then what is apparently an amitotic division. After this there is rhythmic

growth of the nuclei of secreting cells, giving six size classes 1:2:4:8:16:32, all of which are correlated with distinct phases of secretory activity.

It is, of course, well known that great variation in nuclear size can occur, both normally and in experiments, without reproduction of the constituent chromosomes or other permanent change in structure. Sometimes increase in nuclear volume is associated with enlargement of the nucleolus. Metz and his students have shown particularly clearly by *in viva* experiments that when hypertonic Ringer solution is injected into the body cavity of *Sciara* larvae the nuclear and chromosome volume of the salivary gland cells both decrease by at least 25 per cent. With hypotonic solutions there is an increase of at least 20 per cent. Complete recovery occurs. They found also that reversible nuclear shrinkage occurs when cells are under pressure. Upon asphyxiation of *Sciara* larvae with CO₂ or N₂ for 1-3 minutes, the nuclear volume of salivary glands remains unchanged, but the chromosomes shrink and contract into a ball. When shrinking they give out a clear fluid into the nucleus, and when recovery occurs this is reabsorbed by the chromosomes.

The regular alterations in nuclear size described above for many animal tissues occur also in plants (Höppner, 1939). They are often correlated with multiplication of the chromosomes within the nucleus or of the chromonemata within the chromosomes. Berger (1938) has reinvestigated the polyploidy long known to occur in mosquitoes. He found that in *Culex pipiens*, with $n = 3$ chromosomes, the ileum of the larva grows without mitosis until the nuclei are 8-16 times the normal volume. When mitoses begin, up to 48 chromosomes are commonly observed, and some nuclei have 96, which is 32-ploid. The chromosomes must therefore have divided three or four times during the long larval development without division of the nucleus occurring. Geitler (1938) called this phenomenon "endomitosis" and found it to occur in many tissues of insects such as the Malpighian tubules, testis septa, follicular epithelium, fat bodies, salivary glands, connective tissues, and epithelium of the mid-gut. A particularly high degree of polyploidy was found in the salivary gland nuclei of *Gerris*. The X chromosome of *Gerris* is heterochromatic, and the number of chromosome sets could therefore be determined by counting the heterochromatic bodies; thus the number of chromosomes can be estimated though the nucleus is not dividing mitotically. As high as 2,048-ploid nuclei were found. It is not known whether in insects the polyploid tissues which divide mitotically

owe their origin to endomitoses. Such somatic polyploidy is common (see Oksala, 1939). Smith (1941) found the chromosome number to be doubled in wing buds of sawflies (Hymenoptera), i. e., to be $2n$ in males and $4n$ in females. In the ovariole wall it was octoploid and in neural cells $20-30n$. In leguminous plants, Wipf and Cooper (1938) found that dividing cells in the root nodules, which are involved in the process of nitrogen fixation, are characteristically tetraploid.

The clearest case of endomitosis in plants occurs in spinach, $2n = 12$, where somatic polyploidy has long been known, but its origin due to endomitosis was shown only recently by Gentcheff and Gustafsson (1939). They find that in the periblem cells of roots from germinating seeds, the nuclei have as many as 96 chromosomes. This polyploidy is correlated with the presence of a large amount of storage products in the periblem cells. The chromosomes are split at the beginning of prophase. At metaphase they lie in pairs and do not separate. After a resting stage they are present in the double number and unpaired. Levan (1939) obtained similar results in auxin-treated cortical cells of spinach. In *Allium*, auxin produced endomitosis differing only in that the kinetochores were delayed in their division relative to the arms, and "diplochromosomes" were therefore present at metaphase. In these experiments with auxin, cellular enlargement precedes the increase in nuclear volume, and endomitosis appears to be initiated thereby. In most of the other cases cited, chromosome or chromonema multiplication precedes and apparently initiates the increase in nuclear volume. This is also the case in polyploidy produced experimentally with colchicine. Colchicine apparently inhibits the centrosome or spindle activity and sometimes the reproduction of the kinetochore, but not that of the chromonema. Levan obtained cells with as many as 1,000 diplochromosomes, i. e., chromosomes divided except at the kinetochore, in *Allium* which normally has 16.

The giant chromosomes of the salivary gland nuclei of *Diptera* are now generally, though not universally, conceded to be bundles of chromonemata. They appear to result from successive endomitoses which apparently differ from the foregoing cases chiefly in that the chromonemata remain associated, instead of falling apart and constituting separate chromosomes, and that homologues become tightly paired. These differences may both well be concomitants of the closer association which exists between homologous chromosomes in all cells of the *Diptera*—Metz (1916) showed that in poly-

ploid as well as diploid cells of *Drosophila*, the homologous chromosomes all tend to lie together.

The fact that endomitosis provides a way in which the nucleoprotein content of a nucleus may be increased, and the apparent association of endomitotic chromosome or chromonema multiplication with secretory or nutritional function have naturally led to a good deal of speculation on the mechanism of the exchange which must take place between the nucleus and the cytoplasm. Without going seriously into this problem an indication of the present state of opinion may be given by citing three papers which appeared in close succession in the same *Journal* last year. Painter (1940) suggests that rapidly segmenting eggs can draw the material for the synthesis of their chromosomes from the chromatin or its derivatives that have been produced by endomitosis and poured out into the cytoplasm by the breakdown of the germinal vesicle, or by indirect absorption from nurse cells. Calvin, Kodani, and Goldschmidt (1940) consider that salivary gland chromosomes are essentially of the same structure as mammalian egg "lampbrush" chromosomes from which they consider chromatin is being sloughed off. Caspersson and Schultz (1940), however, point out that the high concentration of ribonucleic acid in the cytoplasm occurs before the nuclear membrane breaks down. They observe that the cytoplasm or nucleolus which does not ordinarily stain with Feulgen does contain nucleic acids which must be assumed to be of the ribose type. There is a high concentration of these around the nuclear membrane in several rapidly growing tissues and a gradient from it to the outside of the cell. The amount of ribonucleic acid in the cytoplasm can be increased by adding heterochromatin (in particular by adding extra Y chromosomes in *Drosophila*). It seems that more must be learned of the relationships between different nucleic acids before we can proceed much further with this problem. The same applies to the relationship between the chromosomes and the nucleolus. Of the latter, Nebel (1939) says, "The understanding of this problem has not progressed far during the last fifty years" and "recent work has further emphasized the complexity of the problem in that it is necessary to avoid all generalizations." Caspersson and Schultz commit themselves to little in this connection except to state that nucleoli are produced in heterochromatic regions, that these regions "are especially concerned with the ribonucleic acid metabolism of the cell," and that "activity of nucleoli is closely associated with an intense synthesis of the cytoplasmic ribonucleic acids." Since the heterochromatic regions stain

deeply with Feulgen during the "resting" stage, they must, however, be rich in *desoxyribonucleic acids* at that time. The work of McClintock (1934) on the nucleolar-forming body in Maize, and that of Navashin, Heitz, and others on various plants, besides establishing morphological and developmental relationships, indicates possible lines of attack on problems of nucleolar function.

We may proceed now to a discussion of some features of chromosome structure for which submicroscopic interpretations are as yet either very limited in scope or else highly speculative. Very diverse opinions have been expressed by different workers on the function or even the existence of the matrix of the chromosomes. Darlington (1935a) dismisses it entirely but concedes that "the chromosome thread probably has some sort of pellicle." Heitz and Kuwada, respectively, introduced the terms *kalymma* and *hyalonema*. These and others are, as Nebel (1939) says, "synonymous terms for a morphological entity, at present insufficiently defined in terms of chemical constitution." Some authors, including myself, consider that there is evidence for both matrix and a sheath or pellicle. Nebel considers each chromonema to have its own matrix and all the chromonemata of a chromosome to have, in addition, a common matrix. However this may be, it may be taken as established that the chromosomes in mitosis and meiosis consist of chromonemata surrounded by a substance for which we may as well use the now noncommittal term matrix until more is known of its nature, structure, and function.

From this point we may logically consider next the problem of the number of chromonemata and their arrangement within the chromosomes during division. As Nebel (1939) has so recently presented an extensive review of chromosome structure, only a brief outline, particularly of those problems still at issue, will be given here. The detailed nature of the coiling of the chromonemata within mitotic or meiotic chromosomes and the mechanisms concerned in coiling have engaged much attention since about 1925 when Kaufmann demonstrated it clearly in pollen mother-cell meiosis of plants with large chromosomes. More recently spiral structure has been established definitely in *somatic* chromosomes of plants, in grasshoppers (White, 1940), sawflies (Smith, 1941), a mammal (Koller, 1938), and protozoa (Cleveland, 1938). Though it has not yet been clearly demonstrated in many animals nor in plants with very small chromosomes, it seems a fairly safe assumption that the condensed chromosomes characteristic of mitosis and meiosis in most organisms all have a coiled structure and that spiralization is the chief mechan-

ism of "condensation" or better, of "packing" (Darlington). Maximum spiralization occurs at metaphase or early anaphase in plants with large chromosomes (and probably in almost all organisms) but at the end of anaphase in some protozoa (Belar, 1926, Bauer, 1938). For the purpose of analysis it is necessary to consider the many different forms that coiling may take or stages that may occur in the process. The chromonema within each chromatid of a mitotic chromosome forms a helix which is best termed a standard coil (Nebel, 1939). The two chromatids are twisted about each other like the two strands of electric flex, i. e., they are extended coils turning in the same direction. This is termed relational coiling (Darlington, 1935b). In the prophase of mitosis, especially in the first microspore division, the chromonemata are in loose spirals which Darlington termed relic coils. They have now definitely been shown, in pollen grain divisions, to be the residuum of the coils of the previous division, as his term implies (Sparrow, Huskins, and Wilson, 1941).

At the metaphase and anaphase of meiosis, there is typically a coil of much larger diameter. Fujii, in 1926, first described the chromonema forming this coil as being itself a small-gyred spiral. These two helices are now generally termed the major and minor coils (Huskins and Smith, 1935). In some organisms, e. g., *Trillium*, the major coil persists relatively unchanged through both divisions of meiosis and appears as a large-gyred relic coil in the prophase of the first pollen grain division. In others, e. g., *Tradescantia*, the major coil disappears during meiotic interkinesis and a new smaller-gyred spiral appears in the second division.

In my opinion much confusion has resulted from the use of terms with implications beyond those warranted by the existing data and from failure to keep theory sharply differentiated from observation. For instance, the major and minor coil were originally termed primary and secondary, and the terms were then interchanged as evidence accumulated on their relationship. The small-gyred coil of the second meiotic division in *Tradescantia* and that of somatic cells have often been called minor coils, thus implying a relationship with the minor coil of the first division of meiosis which is not yet established. The frankly deductive hypothesis of coiling presented by Darlington (1935b) relates all the different coils, and traces them back to an assumed molecular spiral unitarily controlled from the centromere or kinetochore. Certain of Darlington's followers took the molecular spiral as a datum and when they found

changes in direction of the major coil or in the salivary gland chromosomes, explained them away, or in some cases ignored them, because they could not, of course, be accommodated to a theory having this basis. Similarly, many other workers presented figures of drawn-out major spirals as evidence for the minor spiral concept of Fujii, Kuwada, *et al.* Further confusion resulted from disagreement on the number of chromonemata within meiotic chromosomes. Kuwada and Nakamura (1933), in one of the first presentations in English of the work of the current Japanese school, showed the coil-within-a-coil structure by means of a diagram containing four strands. This *diagram* was adopted by the Darlington school since it agrees with their concept of the number of strands. Kuwada and Nakamura had, however, already pointed out in publications in Japanese that there is a further split in each of the chromatids in the second division, and they stressed this point in a publication in English in the following year (1934). They and others have since brought forward much evidence for the existence of at least eight strands in a meiotic bivalent. The Darlington school, however, still sees only four. It is obvious that optical images can be given very different interpretations as coils when such a disagreement exists on the number of strands. It has also been pointed out (Huskins, 1937) that the minor coil of some workers is a tightly wound helix, while that of others is a mere waviness. The former would most easily be explicable as the result of its molecular structure; the latter may be interpreted as the initiation of a spiral determined by mechanical forces. There are also differences of opinion on the relationship between the two major coils formed by the two chromatids of a meiotic chromosome. Some authors have pictured them as intertwined; to get them separated Matsuura has postulated breaking and rejoining (genetic crossing-over) during anaphase—for which there is no evidence. Most observers, however, find the chromatid spirals twisted on their own axis but free of each other.

In the hope of resolving these differences of opinion on the interpretation of microscopic images, efforts have been made, but with very meager success, to obtain evidence from other levels. Polarized light experiments were for some time held to prove the existence of a minor spiral at right angles to the major spiral, but it is now generally conceded that the existing data on birefringence of chromosomes are equivocal (cf. Frey-Wyssling, 1938). Innumerable experiments have been made to determine the number of chromonemata through the breakage effects of X-rays. The results

have mostly been interpreted in accordance with the opinion the investigator had previously formed from direct microscopic observation. The opinion is now gaining ground that X-rays are too crude a tool for settling this problem. Fourth level data show that there are four genetically effective strands in a meiotic bivalent so far as crossing over is concerned, but this says nothing of the structure within each of these.

In our McGill laboratory we have, during the last five years, attempted to get more definite evidence on some of these problems by starting with statistical analyses of extensive data from the largest and most easily observed spiral structures. For this purpose *Trillium* is exceptionally favorable material.

Our first significant observation was that the major coil changes direction at numerous points in *Trillium*. By analysis of normal material and comparison with pollen mother-cells that had different degrees of lack of association between homologous chromosomes and sister chromatids through temperature treatments, we have been able to establish (Huskins and Wilson, 1938) that reversals occur with random frequency at the kinetochore and at chiasmata, and that elsewhere they may occur from unknown causes with a frequency proportional to the length of chromosome involved. It was next discovered (Wilson and Huskins, 1939) that the chromonema more than doubles in length during formation of the major coil—the nature of the elongation is not yet determined. These facts seem decisively to rule out any hypothesis which involves an internal torsion due to molecular pattern *and directed as a unit*. They are fitted for the present by the simple assumption that a thread of a resilient consistency will take up a spiral form if it expands in length within a confined space—the sheath or pellicle. Almost surely this concept will be found inadequate to explain some of the other spirals now being studied.

The relational coil has generally been assumed to result from torsion causing the chromonemata to twist around each other. Our current data (Sparrow, Huskins, and Wilson, 1941) show that the microspore chromatid relational coiling results directly from the partial straightening out of the gyres of the major coil of meiosis and is related to the plane assumed by the tertiary split in the major coil. This cannot, of course, be the direct cause of the relational coiling of homologous chromosomes in the prophase of meiosis—which requires much more rigid analysis than it has yet received. We are proceeding at present with analyses of standard somatic

coils. The torsion hypotheses of coiling and crossing over have also been checked by analyses of the relationship of successive chiasmata (Huskins and Newcombe, 1941). These reveal a more complex relationship than previously envisaged, and experiments with *Neurospora* (Lindgren and Lindgren, 1937 and unpublished) seem to substantiate the results with fourth level, genetic data.

To sum up: The structure of the nucleus is highly involved and changes in it are being correlated with function. Studies of the nucleus are proceeding on four different levels which differ considerably in the degree of accuracy or objectivity attainable. First-level analyses of chromosomes have led to hypotheses on their molecular pattern. Ultraviolet and Feulgen studies of the nucleus have established the nucleic acid cycle during mitosis and interkinesis. The conclusions from these regarding the time of reproduction of the gene rest, however, partly on second-level or microscopic observations of the time of chromosome or chromonema reproduction, regarding which there are sharp differences of opinion. They are, therefore, much less definitely established than the first-level data on which they may appear to be based. Microchemical studies on genetically controlled materials involving heterochromatic regions (combined first-, fourth-, and third-level studies) indicate: (a) that heterochromatic regions are specialized for the production of nucleic acid, (b) that they are concerned in the formation of the nucleolus, and (c) that the position of genes relative to these regions affects the expression of the characteristics they determine. The functions of nucleoli of different types remain undetermined.

Second-level microscopic studies are now very frequently combined with fourth-level, genetic analyses. Where the correlation is experimental, very solid progress has been made. One school of second-level cytology uses genetic data extensively for the deductive formulation of cytological hypotheses (Darlington, 1935a and b). Very great advances have been made by this technique, but the dangers inherent in the method are apparently not realized by all those following it, nor is the admittedly tentative nature of some of the conclusions drawn by this school realized by many workers on other levels who attempt correlations of them with their own data.

Third-level studies by the methods of experimental cytology have not been considered to any extent in the above brief review, since they are considered by another contributor to this symposium. Only limited aspects of the problems of mitosis have been considered since this process obviously depends upon reactions of the cell

as a whole and only nuclear problems are here considered in any detail. The coiled structure of meiotic and mitotic chromosomes is being studied comprehensively by the deductive school and piecemeal by others, including our own group, who are attempting to remain more inductive in their approach. Coiling is being related by both schools to mechanical function during nuclear division. The structure of the resting or "energetic" (Berrill and Huskins, 1936) nucleus is fairly evidently correlated with physiological function, and cytogenetic methods of attacking this problem are available (cf. Stern, 1938).

Progress is apparently being made most rapidly in nearly all of the problems of the nucleus when attacks are made by associations of workers with training in the different techniques of the four "levels" into which, for the purpose of stimulating discussion, analyses of nuclear structure are here somewhat arbitrarily grouped.

BIBLIOGRAPHY

- BAUER, H. 1938. Chromosomenstruktur. Arch. Exp. Zellf. 22: 181-187.
- BELAR, K. 1926. Der Formwechsel der Protistenkerne. Erg. Fortschr. Zool. 6: 235-652.
- BERGER, C. A. 1938. Multiplication and reduction of somatic chromosome groups as a regular developmental process in the mosquito, *Culex pipiens*. Carnegie Inst. Wash. Publ. 496: 209-232.
- BERRILL, N. J., AND HUSKINS, C. L. 1936. The "resting" nucleus. Am. Nat. 70: 257-261.
- BRACHET, J. 1940. La localisation de l'acide thymonucleique pendant l'oogenese et la maturation chez les amphibiens. Arch. Biol. 51: 151-165.
- CALVIN, M., KODANI, M., AND GOLDSCHMIDT, R. 1940. Effects of certain chemical treatments on the morphology of salivary gland chromosomes and their interpretation. Proc. Nat. Acad. Sci. 26: 340-349.
- CASPERSON, T. 1936. Über den chemischen Aufbau der Strukturen des Zellkernes. Skand. Arch. Phys. 73: Suppl. 1-151.
- . 1939a. Über die Rolle der Desoxyribosenukleinsäure bei der Zellteilung. Chromosoma 1: 147-156.
- . 1939b. Studies on the nucleic acid metabolism during the cell cycle. Arch. Exp. Zellf. 22: 655-657.
- . 1940. Methods for the determination of the absorption spectra of cell structure. Jour. Roy. Micr. Soc., Ser. 3, 60: 8-25.
- AND SCHULTZ, J. 1940. Ribonucleic acids in both nucleus and cytoplasm, and the function of the nucleolus. Proc. Nat. Acad. Sci. 26: 507-515.
- CLEVELAND, L. R. 1938. Longitudinal and transverse division in two closely related flagellates. Bio. Bul. 74: 1-40.
- DARLINGTON, C. D. 1935a. The old terminology and the new analysis of chromosome behaviour. Ann. Bot. 49: 579-586.
- . 1935b. The internal mechanics of chromosomes. Proc. Roy. Soc. B. 118: 33-96.
- . 1937. Recent Advances in Cytology. 2nd ed., pp. 1-671.

- AND LA COUR, L. 1940. Nucleic acid starvation of chromosomes in *Trillium*. Jour. Genet. 40: 185-213.
- FISCHER, I. 1935. Über den Wachstumsrhythmus des Follikel-epithels der Lause und Federlinge und seine Beziehungen zum Arbeitsrhythmus der Zelle und zur Amitose. Zschr. Zellf. 23: 219-243.
- FREY-WYSSLING, A. 1938. Submikroskopische Morphologie des Protoplasmas und seiner Derivate. Protoplasmanomographien 15: 1-317.
- GEITLER, L. 1938. Chromosomenbau. Protoplasmanomographien 14: 1-190.
- GENTSCHKEFF, G., AND GUSTAFSSON, A. 1939. The double chromosome reproduction in *Spinacia* and its causes. I-II. Hereditas 25: 349-386.
- HEITZ, E. 1935. Chromosomenstruktur und Gene. Zschr. Ind. Abst. Vererb. 70: 402-447.
- HILLARY, B. B. 1940. Uses of the Feulgen reaction in cytology. II. New techniques and special applications. Bot. Gaz. 102: 225-235.
- HUSKINS, C. L. 1937. The internal structure of chromosomes—a statement of opinion. Cytologia, F. J. 2: 1015-1022.
- AND NEWCOMBE, H. 1941. An analysis of chiasma pairs showing chromatid interference in *Trillium erectum* L. Genetics 26: 101-127.
- AND SMITH, S. G. 1935. Meiotic chromosome structure in *Trillium erectum* L. Ann. Bot. 49: 119-150.
- AND WILSON, G. B. 1938. Probable causes of the changes in direction of the major spiral in *Trillium erectum* L. Ann. Bot. N. S. 2: 281-292.
- JACOB, W. 1925. Das rhythmische Wachstum der Zellen durch Verdoppelung ihres Volumens. Arch. Entw. mechan. 106: 124-192.
- KOLLER, P. C. 1938. The genetical and mechanical properties of the sex chromosomes. IV. The Golden Hamster. Jour. Genet. 36: 177-195.
- KOLTZOFF, N. K. 1938. The structure of the chromosomes and their participation in cell metabolism. Biol. Zhurnal 7: 2-46.
- KUWADA, Y., AND NAKAMURA, T. 1933. Behaviour of Chromonemata in mitosis. I. Observation of pollen mother cells in *Tradescantia reflexa*. Mem. Coll. Sci., Kyoto Imp. Univ., Ser. B. 9: 129-139.
- . 1934. Behaviour of chromonemata in mitosis. IV. Double refraction of chromosomes in *Tradescantia reflexa*. Cytologia 6: 78-86.
- LEVAN, A. 1939. Cytological phenomena connected with the root swelling caused by growth substances. Hereditas 25: 87-96.
- LINDEGREN, C. C., AND LINDEGREN, G. 1937. Non random crossing over in *Neurospora*. Jour. Hered. 28: 105-112.
- MAZIA, D., AND JAEGER, L. 1938. Nuclease action, protease actions, and histochemical tests of salivary chromosomes of *Drosophila*. Proc. Seventh Int. Genet. Con., p. 212.
- MCCLINTOCK, B. 1934. The relation of a particular chromosomal element to the development of the nucleoli in *Zea mays*. Zschr. Zellf. 21: 294-328.
- METZ, C. W. 1916. Chromosome studies in the Diptera. II. Jour. Exp. Zool. 21: 213-279.
- MILOVIDOV, P. 1938. Bibliographie der Nucleal-und Plasmalreaktion. Protoplasma 31: 246-266.
- NEBEL, B. R. 1939. Chromosome structure. Bot. Rev. 5: 563-626.
- OXSALA, T. 1939. Über Tetraploidie der Binde- und Fettgewebe bei den Odonaten. Ein Beitrag zur Kenntnis der sog. somatischen Polyploidie der Insekten. Hereditas 25: 132-144.
- PAINTER, TH. S. 1940. On the synthesis of cleavage chromosomes. Proc. Nat. Acad. Sci. 26: 95-100.
- SCHMITT, F. O. 1940. The molecular organization of protoplasmic constituents. Coll. Net. 15: 1-7.

- SCHULTZ, J., CASPERSSON, T., AND AQUILONIUS, L. 1940. The genetic control of nucleolar composition. *Proc. Nat. Acad. Sci.* 26: 515-523.
- SHMARGON, E. N. 1938. Analysis of the chromomere structure of mitotic chromosomes in Rye. *C. R. Acad. Sci. URSS.* 21: 259-262.
- SMITH, S. G. 1941. A new form of spruce sawfly identified by means of its cytology and parthenogenesis. *Sci. Agr.* 21: 245-305.
- SPARROW, A. H., HUSKINS, C. L., AND WILSON, G. B. 1941. Studies on the chromosome spiralization cycle in *Trillium*. *Can. Jour. Res.* 19:323-350.
- STERN, C. 1938. During which stage in the nuclear cycle do the genes produce their effects in the cytoplasm? *Am. Nat.* 72: 350-357.
- WERMEL, E. M., AND PORTUGALOW, W. W. 1935. Studien über Zellengröße und Zellewachsstum. XII. Mitteilung. Über den Nachweis des rhythmischen Zellenwachstums. *Zschr. Zellf.* 22: 185-194.
- WHITE, M. J. D. 1940. The heteropycnosis of sex chromosomes and its interpretation in terms of spiral structure. *Jour. Genet.* 40: 67-82.
- WILSON, G. B., AND HUSKINS, C. L. 1939. Chromosome and chromonema length during meiotic coiling in *Trillium erectum* L. *Ann. Bot., N. S.* 3: 257-270.
- WIPF, L., AND COOPER, D. C. 1938. Chromosome numbers in nodules and roots of red clover, common vetch and garden pea. *Proc. Nat. Acad. Sci.* 24: 87-91.

PROTOPLASMIC STREAMING IN RELATION TO GEL STRUCTURE IN THE CYTOPLASM

DOUGLAS A. MARSLAND

Washington Square College of Arts and Science, New York University

I. INTRODUCTION

Reversible sol-gel transformations are commonly recognized in protoplasmic systems, and for some time it has been thought that these reactions may play an important role in physiological activity. Thus Mast ('26 and '31), and Lewis ('39) have considered that the movement of amoeboid cells depends upon a series of gelations occurring at the anterior ends of the pseudopodia, and upon compensating processes of solation in the posterior part of the cell. Aside from this case, however, examples establishing the physiological importance of sol-gel reactions have not been demonstrated very clearly.

A. SOL-GEL EQUILIBRIA IN RELATION TO HYDROSTATIC PRESSURE

A relationship between hydrostatic pressure and the structural characteristics of protoplasmic gels was first revealed by Dugald E. S. Brown in 1934. Brown ('34c) found that the central mass of the *Amoeba* egg is relatively fluid compared to a cortical layer, about 5 microns thick, which displays the properties of a fairly rigid gel. When these eggs were centrifuged at atmospheric pressure in a weak centrifugal field, the granular components of the central fluid protoplasm were readily displaced, but the granules of the gelated cortex, mainly the pigment granules, remained quite fixed. But when the centrifuging was done at increasingly higher hydrostatic pressure, up to 10,000 pounds per square inch, the cortical gel displayed a greater and greater degree of liquefaction. In the higher range of pressure the pigment granules were displaced with great rapidity, and at 10,000 lbs./in.,² the cortical gel offered less than 10 per cent of its atmospheric resistance.

Subsequent work has demonstrated that hydrostatic pressure imposes solation upon the protoplasmic gels of animal and plant cells generally. Among the animals, the effect has been shown in a number of different eggs;¹ in two kinds of amoeba,² in the tentacles of

a suctorian³ (Ephelota), in Paramecium,⁴ and in human erythrocytes.⁴ Among the plants a similar effect has appeared in the leaf cells of Elodea,⁵ in the plasmodium of Physarum,⁶ and in the cells of Spirogyra.⁴

A number of the cases have yielded quantitative measurements, and these indicate that the *relative* magnitude of the liquefaction induced by pressure is the same in all cases, regardless of whether the initial gel at atmospheric pressure is quite firm or is relatively fluid. Each increment of 1,000 lbs./in.² reduces the rigidity by almost 25 per cent. Furthermore, within fairly broad limits, the effect is reversible. Pressures up to 4,000 lbs./in.² may be maintained for about an hour, and yet, when the cells are returned to atmospheric pressure, the original structural characteristics of the gel are restored within a minute, or perhaps within an even shorter time. For higher pressures irreversible changes begin to appear much sooner, depending upon the intensity.

B. STATEMENT OF THE PROBLEM

Since it is known that pressure induces solation, or conversely, that pressure prevents gelation from occurring in protoplasmic systems, a useful tool has been provided for analyzing the role of such phenomena in various forms of physiological activity. At the present time quite a number of studies are available, and the purpose of this paper is to determine, so far as is possible, how the manifold physiological effects of pressure may be related to changes in the sol \rightleftharpoons gel equilibrium.

C. STREAMING ACTIVITIES IN CONTRAST TO OTHER PHYSIOLOGICAL PROCESSES

Perhaps a general statement of the results, made in advance of the detailed account, will provide a useful orientation. In general, it seems valid to say that one group of physiological activities, the group in which protoplasmic streaming is the common attribute, appears to be particularly vulnerable to inhibition by very moderate (below 5,000 lbs./in.²) intensities of compression. This pressure-susceptible group includes amoeboid movement, cyclosis, cell division (in animal cells), and the migration of pigment in the unicellular type of chromatophores.

A second group of activities, which includes contraction in muscle, conduction in nerve, and the motility of cilia and flagella, is not inhibited by moderate pressures. In fact, the characteristic activities

of the second group are considerably augmented or accelerated in the lower range of pressure. Furthermore, it may be said that the effect of pressure upon the activities of the first group is in proportion to the effect upon the gel system, whereas this does not seem to be the case for the second group.

II. METHOD

A. DIFFERENCES BETWEEN HYDROSTATIC AND OTHER TYPES OF COMPRESSION

It is important to realize that the pressure used in the experiments is of the hydrostatic type. Each cell or tissue is completely surrounded by a liquid medium, and this medium serves to transmit the pressure from the pump *equally in all directions*. This condition eliminates all distortional injury, such as would result if the tissues were compressed locally between impinging solid surfaces. The difference is well illustrated by experiments on dividing *Arbacia* eggs. When these cells are compressed between a slide and coverslip, less than 5 lbs./in.² suffices to cause considerable distortion and to block the cleavage. Under hydrostatic compression, however, the form of the egg remains unchanged, aside from a very slight loss of volume, at pressures well above 10,000 lbs./in.², and the capacity to furrow is not completely abolished until a pressure of more than 5,000 lbs./in.² is reached.

Another important experimental condition is the absence of any gas phase in the system. Many of the early experiments in the field were complicated by the fact that the pressure was applied through the medium of a supernatant atmosphere. This made it difficult to distinguish between the effects of the pressure per se, and the effects of driving excessive quantities of the atmospheric gases into solution in the protoplasm and the surrounding liquid medium. When the gaseous phase is eliminated, the main effect of the pressure must be mediated through small changes in the protoplasmic volume⁷ and through the consequent alterations in the fundamental molecular pattern of the protoplasmic system.

B. RECENT TECHNICAL DEVELOPMENTS

All of the experimental methods cannot be given in detail, but a brief consideration of two recently developed pieces of apparatus will permit a clearer understanding of the ensuing work. The first is the centrifuge-pressure bomb devised by Brown ('34c). This

apparatus makes it possible to centrifuge a tissue while the compression is maintained at any desired level up to 14,000 lbs./in.² Thus one may measure, by the centrifuge method, the fluidity of the protoplasmic system as a function of pressure. The bomb is divided into two parts; (1) the experimental, or pressure chamber, and (2) the control chamber. A needle valve seals the pressure into the experimental chamber during the period of centrifugation, and since the centrifugal radius is the same for both chambers, the control (atmospheric), and the high pressure specimens are subjected to an equal centrifugal force.

The second apparatus is the microscope-pressure chamber described by Marsland and Brown in 1936. In this chamber, specimens may be viewed during the period of compression at magnifications up to 600 diameters.⁸ Upper and lower windows, 3 mm. thick, permit light to be transmitted through the chamber to a special objective⁹ which, despite an unusually great working distance of 15 mm.,¹⁰ possesses a magnification of 15 diameters. Since the specimens in the chamber tend to drop to the upper surface of the lower window, the bomb is used with an inverted microscope, and good images are obtained with oculars up to 20 \times .

III. CELLULAR ACTIVITIES WHICH INVOLVE PROTOPLASMIC STREAMING

A. AMOEBOID MOVEMENT

The dependence of this activity upon the structural characteristics of the gel system of the amoeboid cell has been demonstrated by several types of experiment (Brown and Marsland, '36, and Marsland and Brown, '36).

(1) *Effects of high pressure, rapidly established*

In this type of experiment, the amoebae were placed in the pressure chamber and then, while under continuous observation, were rapidly compressed at the rate of about 1,500 lbs./in.² per second.

The first effect of the compression is the cessation of the protoplasmic flow when the pressure reaches about 4,000 lbs. Then no further change is noted until the pressure reaches approximately 6,500 lbs. At this point, within 0.5 second each elongate pseudopodium undergoes a sudden shrinkage in length and develops a terminal sphere of the type shown in Figure 1. This abrupt and rapid reorganization of the pseudopodium is followed by a more

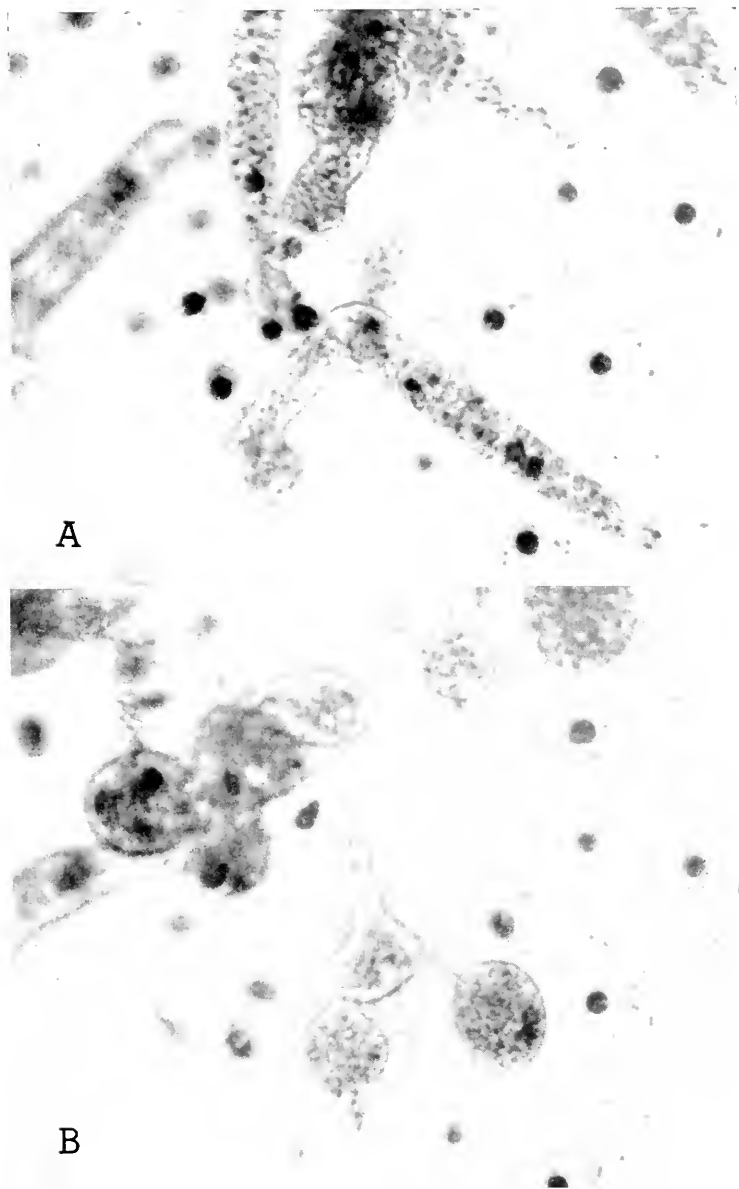

FIG. 1. Solution of the plasmagel of the pseudopodia of *Amoeba dubia*. In A, the specimens are at low pressure (1,500 lbs. in.²). Note that characteristically the pseudopodia are elongate cylinders. B shows the same specimens 1 second after raising the pressure to 6,500 lbs. in.² Due to the greater fluidity of the plasmagel, each pseudopodium undergoes a rapid reorganization, tending to become spherical as a result of the tensional forces of the surface.

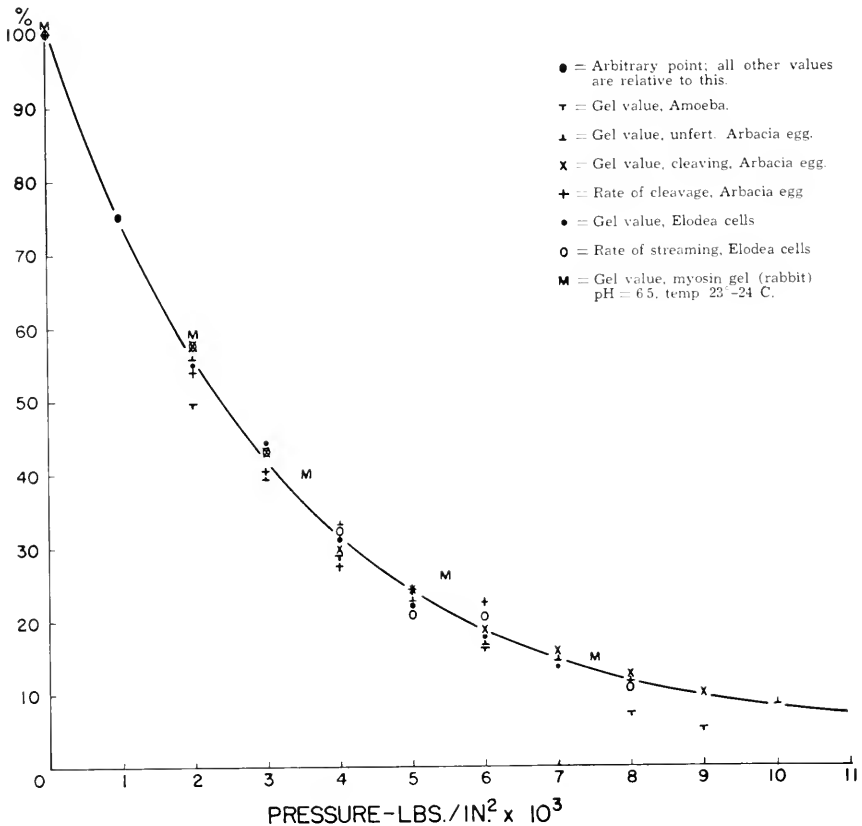

FIG. 2. Proportionality between the effects of pressure on protoplasmic streaming (and cell division) and the degree of solation imposed by pressure, in various gel systems. The data for the myosin gel are entirely tentative, since only points nearest the general curve were selected from several preliminary experiments.

gradual change in the entire form of the amoeba such that in about 5 minutes all of the specimens become quite spherical.

This type of experiment clearly indicates that the tubular form of a pseudopodium is maintained by rigid properties which are inherent in the plasmagel layer. The data of Figure 2 reveal that the rigidity of this layer at 6,500 lbs. is less than 20 per cent of its atmospheric value. When the rigid properties of the gel are lost, the pseudopodium behaves as a cylinder¹¹ of nonmiscible liquid suspended in water and becomes unstable under the tensional forces of the surface.

The foregoing reaction is exhibited most strikingly in the case of *Amoeba dubia*. With *Amoeba proteus* the formation of the terminal spheres is not so well marked and requires slightly higher pressures. In this case and in the case of the amoebocytes of the body fluid of *Arbacia* the sudden collapse of many of the pseudopodia is represented chiefly by an abrupt shrinkage in length. In all cases, however, the cells gradually become spherical if the high pressure is maintained.

A similar phenomenon has been observed by Kitching and Pease, '39, who studied the behavior of the tentacles of the suctorian protozoa, *Ephelota coronata*. In this case the disintegration, which occurred mainly at pressures between 6,500 and 8,500 lbs./in.,² was so complete that the suctorial processes broke up into tiny isolated beads of protoplasm. This difference is probably due to the greater length of the tentacular processes and to the absence of a visibly differentiated surface membrane such as is present in the *Amoeba*.

(2) *Indications of a gradient in the tensile properties of the plasmogel*

It is significant to note in the *Amoeba* experiments that the rigidity of the plasmagel varies somewhat in different parts of the pseudopodium. Thus in a newly formed pseudopodium, which is actively extending at the moment of compression, the terminal sphere may involve all but a short remnant at the base, whereas in older less active ones, only the distal tip may be involved. Assuming that pressure produces the same percentage loss of rigidity in all parts of the plasmagel system,¹² these observations indicate that normally the plasmagel is more fluid in the more recently formed parts of the pseudopodium. They also support the view of Mast ('26), namely, that a gradient of rigidity exists in the plasmagel tube, decreasing as one proceeds from the base to the tip of the pseudopodium.

(3) *Measurement of the solating effect of the pressure*

The experimental results (Brown and Marsland, '36), which clearly describe the solution of the plasmagel as a function of pressure, are given in Figure 2. The gelation percentages¹³ are taken to be in proportion to the time of centrifugation¹⁴ required for the formation of a standard hyaline zone (see Fig. 3), measured at each of the indicated levels of pressure.

The formation of the hyaline zone (Fig. 3) requires the displacement of all the formed bodies originally present in this region of the

protoplasm. The greatest resistance to such displacement occurs in the peripheral protoplasm, that is to say, in the plasmagel rather than in the plasmasol. At $7,000 \times$ gravity the displacement of the formed elements of the sol region is practically instantaneous (Heilbrunn, '29).

Consequently, it may be said that the solation measurements obtained deal entirely with the gel portion of the protoplasm of this cell.

(4) *Equilibration to lower pressures, steadily maintained*

In view of the marked effects of the sudden high compression of the Amoebae, it seemed important to ascertain the characteristic form and movement of the specimens when equilibrated to lower pressures which do not induce such a drastic liquefaction of the plasmagel. In the experiments the amoebae were exposed to the desired pressure until the characteristic form was assumed, a matter usually of about 5 minutes. In

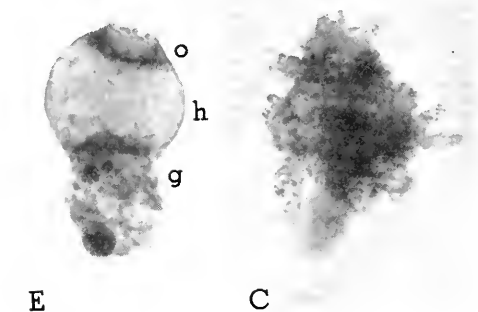

FIG. 3. The solation effect of pressure in the Amoeba. Specimens E (experimental) and C (control) were centrifuged simultaneously for only 10 seconds. E was in the pressure section of the centrifuge at $8,000 \text{ lbs./in.}^2$, whereas C was at atmospheric pressure. The much greater fluidity of the plasmagel of E is indicated by the sharp centrifugal zoning. An equivalent zoning of atmospheric specimens requires more than 3 minutes of centrifuging. Note also in E, that the contractile vacuole was on the point of being thrown out from the centripetal end of the cell at the instant when the nucleus reached the opposite end: o, the oil zone; h, the hyaline zone; g, the granular zone.

most instances the same group of animals was compressed at successively higher pressures and then decompressed, step-wise, through the same pressure range, sufficient time for equilibration being allowed at each pressure.

The variation in form of the Amoebae as a function of pressure involves a progressive diminution in the diameter of the pseudopodia which are formed. At lower pressures, i. e., up to $2,000 \text{ lbs./in.}^2$ there is also a lengthening¹⁵ of the pseudopodia, but thereafter both the length and the diameter are reduced more and more. At $5,000 \text{ lbs.}$ the pseudopodia, although numerous, appear as mere pin points projecting from the surface of the otherwise spherical cell. Above

6,000 lbs. no pseudopodia can be formed or maintained, and the Amoebae become completely spherical. With few exceptions the equilibrium form is assumed by all of the specimens of an experimental group, whether the particular pressure is approached from a higher or a lower level. Apparently each characteristic form represents a steady state with respect to the conditions imposed by the pressure.

The extent to which the variations in the diameter of the pseudopodia may be accounted for on the basis of the increased fluidity of the plasmagel constitutes an interesting question. Essentially, a pseudopodium must be a tube of plasmagel through which the plasmasol flows outward as extension is occurring, and the tubular form of a pseudopodium must be maintained by rigid properties residual in the plasmagel wall. Due to the solating effect of an increase of pressure, a gel layer of equal thickness would possess a lesser strength. On the basis that hydrodynamic factors are involved in the flow of plasmasol, a reduction in the diameter of the pseudopodium can be regarded as a compensation for the diminished strength of the wall. The situation would be analogous to a tube of smaller diameter successfully conducting a fluid which is flowing under a pressure that would be sufficient to rupture the wall if the diameter of the lumen were greater.

Some further observations appear to justify the foregoing viewpoint. At pressures below 3,000 lbs., a range in which an appreciable protoplasmic flow continues, a few of the pseudopodia do not extend steadily in one direction. Instead, the progress of the extending pseudopodium is interrupted at intervals of about 15 seconds by sudden ruptures in the lateral wall, just proximal to the advancing tip. When a rupture occurs, the protoplasmic granules pour rapidly out into the resulting lateral bulge, and then the flow stops altogether for a moment. When the advance begins again, the direction is deflected slightly toward the ruptured side. Such pseudopodia assume a somewhat tortuous form. It would seem probable that this phenomenon indicates an incomplete compensation in the particular pseudopodia which are involved, and that the diameter of these pseudopodia is reduced to a degree which is not quite sufficient to provide stability during periods of active flow.

B. CYCLOSIS

A study of the effects of pressure upon protoplasmic streaming in the leaf cells of *Elodea* (Marsland, '39b), has also established a

dependence of this activity upon $\text{sol} \rightleftharpoons \text{gel}$ reactions. In this case it has been found that the rate of streaming diminishes¹⁶ in proportion to the degree of solation which increasing pressure induces in the nonflowing parts of the protoplasm (Fig. 2).

(1) *The velocity of streaming in relation to pressure*

Qualitative observations on the rate of streaming as a function pressure are relatively easy to make. At 2,400 lbs./in.² the velocity appears to be about half the atmospheric rate. At 5,500 lbs., the chloroplasts continue to move, but the progress is almost imperceptible. Between 6,500 and 7,500 lbs., depending upon the particular cell which is being watched, streaming ceases altogether. However, the flow begins again within about 1 minute after decompression, provided the exposure in the higher range was not too prolonged. In view of such a prompt reversal of the pressure effect, it is not difficult to understand why Fontaine ('29) reported that pressures up to 10,000 lbs./in.² had no immediate effect upon the velocity of streaming, since this worker was unable to see the cells until a few minutes after decompression had occurred.

Quantitative measurements of the rate of streaming are somewhat difficult to obtain. It is necessary to select a cell which can be brought into sharp focus in the pressure chamber, and with a stop watch to time at least ten individual chloroplasts as they pass through a complete circuit, or at least through a definitely fixed major part of the circuit. Although considerable variation is found from cell to cell, the same cell frequently maintains its individual rate, calculated from the average of ten successive timings, for a period of more than half an hour, provided that the light and temperature conditions are kept constant. In such cells it is possible to measure the pressure rate relative to the initial atmospheric rate. In each case the measurements were discarded if, after decompression, the particular cell failed to return, within 5 per cent, to its original atmospheric rate of streaming.

(2) *Measurement of the solation effect*

The very marked solating effect of pressure upon the protoplasm of *Elodea* cells is demonstrated in Figure 4. Leaf A (at 6,000 lbs./in.²) and Leaf B (at atmospheric pressure) were centrifuged in the same field for only 45 seconds. The greater resistance to the displacement of the chloroplasts in the gelled protoplasm of the atmospheric specimen is indicated by the absence of any clear sedimentation zones. Such clear sedimentation zones may be obtained

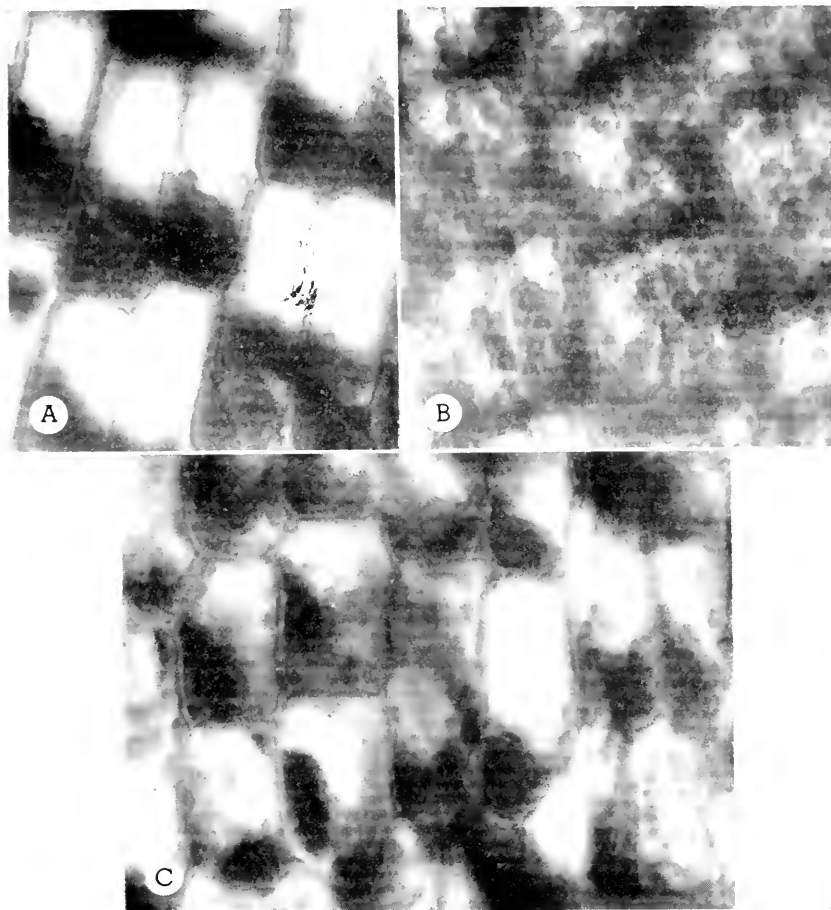

FIG. 4. The solation effect of pressure in the cells of *Elodea canadensis*. Leaves A and B were centrifuged simultaneously for 45 seconds, A at 6,000 lbs. in.² and B at atmospheric pressure. The greater fluidity of A is indicated by the marked sedimentation of the chloroplasts. Leaf C was centrifuged for 4 minutes at atmospheric pressure.

in atmospheric specimens, but only by prolonged centrifugation (about 5 minutes; see Fig. 4-C).

When a leaf is placed in the control, and in the experimental section of the centrifuge-pressure head, care must be taken that the axis of the leaf is fixed in the proper position, i. e., parallel to the radius of the head. Thus the displacement of the chloroplasts and other heavier granules is toward one of the ends of the elongate cells,

rather than toward one of the sides. In each of the experiments the centrifuging was started 1 minute after the pressure was established in the experimental section of the bomb, and a uniform force, $810 \times$ gravity, was used. In view of the fact that protoplasmic streaming, and consequently a redistribution of the sedimented chloroplasts, would begin very shortly after the centrifuging was stopped, it was necessary to fix the material in order to obtain an accurate measurement of the degree of sedimentation. Heat fixation, obtained by placing the bomb in boiling water for 45 seconds, gave excellent results. This method, which avoids chemical contamination of the chamber, was used in all the experiments.

(3) *The plasmagel system in plant cells*

Although it has not been usual to speak of a "plasmal" and "plasmagel" with reference to the protoplasm of plant cells, these terms do not seem inapt, at least in plant cells which display protoplasmic streaming. A close observation of a cell of *Elodea* during active cyclosis shows that, except under special circumstances,¹⁷ only a relatively small portion of the protoplasm is involved in the actual stream. Usually the flowing part is restricted to a fairly narrow channel which follows the side and end walls completely around the cell. The protoplasm which lies above and below this channel, i. e., along the upper and lower margins of the walls, and over the "roof" and "floor" of the cell, does not flow. In these parts of the protoplasm, the chloroplasts, even those which border directly upon the flowing part, may maintain a fixed position for many minutes. Thus the nonflowing portion of the protoplasm resembles the plasmagel of an amoeboid cell, whereas the actively streaming part may be regarded as plasmal.

The gelation percentages, which in Figure 2 have been plotted as a function of pressure, undoubtedly deal with the properties of the plasmagel, rather than of the plasmal portions of the protoplasm. As in the case of the *Amoeba*, the present measurements are based upon the assumption that the relative degree of gelation is in proportion to the minimum time of centrifugation^{1b} required for the formation of a standard zoning at each of the indicated pressures.

C. CELL DIVISION

The effects of pressure upon cell division as it occurs in the eggs of various marine animals have now been reported by several workers (Brown, '34c; Marsland, '36, '38, and '39a; Pease and Marsland, '39; and Pease, '40a), and there is general agreement that

sol \rightleftharpoons gel reactions play an important role in the mechanism which operates to cleave the cytosoma.¹⁹ This view has also been supported recently by other types of work (Schechtman, '37; Chambers, '38; and Dan and co-workers, '37).

(1) *The plasmagel system of egg cells*

On the basis of a number of recent observations, it is possible to compare the egg cell with the *Amoeba* and to distinguish two well differentiated parts of the cytoplasm: (1) the plasmagel,²⁰ a cortically situated layer,²¹ about 5 microns thick, which displays marked gelation changes during the different phases of division, and (2) the plasmasol, the more fluid internal cytoplasm, which participates in the protoplasmic streaming at the time of cleavage, and in which the spindle and the asters are formed.

The existence of a differentiated cortical plasmagel layer in the *Arbacia* egg was first demonstrated clearly by the centrifuge experiments of Brown, '34c, and of Costello, '34. In these experiments it was observed that the formed elements of the cortex undergo centrifugal displacement much less easily than those in the medullary region of the egg, and that displacement of the cortical pigment requires higher centrifugal forces, and longer centrifugal periods. And Costello further observed that the apparent viscosity of the internal protoplasm increases markedly as the temperature falls, whereas the cortical layer, as judged by the displacement of the pigment granules, becomes slightly less "viscous" in the range between 20° and 2° C.

Subsequently there have been a number of confirmatory observations. Motomura, '35, and Schechtman, '37, noted that the protoplasmic currents of the frog's egg, which appear at the time of the cleavage furrow, involve only the deeper cytoplasm, and that visible granules in the peripheral gelled layer are not disturbed by the stream. Chambers, '38, determined that the thickness of the plasmagel layer in the furrow region of the *Arbacia* egg is about 5 microns, by the method of watching the furrow impinge upon a mass of oil which had been injected into the stalk between the blastomeres, replacing the plasmasol in this region. Furthermore, Chambers has observed²² that when one of the two potential blastomeres of a dividing egg is punctured, practically all of the internal cytoplasm pours out from the unpunctured blastomere, through the aperture surrounded by the impinging furrow, leaving a rind of protoplasm which is especially thick bordering the furrow. This cortical remnant displays the properties of a gel, not only in that it

does not participate in the flow of escaping plasmasol, but also in its behavior when manipulated with micro-needles. Finally, the work of Marsland, '38 and '39a, has confirmed and amplified the original observations of Brown.

(2) *The setting of the cortical gel during active cleavage*

An indication that the furrowing process might involve gelation reactions occurring primarily in the cortical layer of the egg cell was provided by Brown's observation ('34c) that when the furrows are about to appear (and during the time when they are actually cleaving the cell), the plasmagel part of the protoplasm becomes set much more firmly than in other phases of the division cycle (see Fig. 5). This very marked shift in the equilibrium is indicated by the fact that no displacement of the pigment granules of the cortex can be obtained even in a relatively strong centrifugal field ($18,000 \times$ gravity, Marsland, '39a) when the eggs are centrifuged during the cleavage period; whereas, if the centrifuging is done shortly before or shortly after this period, a clear displacement can be obtained in relatively weak fields ($7,000 \times$ gravity).

On the basis of the foregoing observations, experiments were undertaken to determine the effects of pressure upon the visible aspects of cleavage in the *Arbacia* egg²³ (Marsland, '38), and upon the sol \rightleftharpoons gel equilibrium of the plasmagel system (Marsland, '39).

(3) *The cleavage block at high pressures*

The first type of experiment involved subjecting the eggs to a relatively high pressure ($7,000$ lbs./in.²) applied suddenly at the time when fairly deep furrows were visible in a majority of the cells. As soon as the pressure is applied, the progress of each furrow ceases. This is true whether the invagination has just begun or whether it has already almost cleaved the egg. Not only does the inward movement of the furrow stop, but soon a slow recession begins (Fig. 6) and if the pressure is maintained, each of the bilobed cells gradually²⁴ reverts to a sphere.

It seemed likely that this phenomenon might be comparable to the slow rounding of amoeboid cells which occurs at a similar pressure. Apparently the bilobed form of the cleaving egg is stable provided that the cortical plasmagel possesses a sufficient degree of rigidity. According to this view the cells become rounded under the agency of surface forces as soon as, due to the solating effect of the pressure, the resistance of the plasmagel drops below a certain critical value.

The inhibition of furrowing by pressure is remarkably reversible.

As soon as the pressure is released the furrow recedes no further, and within less than a minute it begins to push inward once more toward the axis. The delayed furrowing now continues rapidly to completion, provided that the pressure inhibition has not been maintained for more than 14 or 15 minutes.²⁵ No injury appears to result

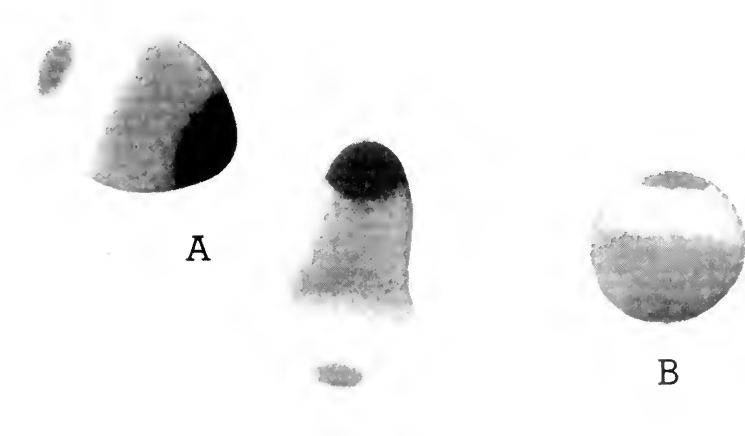

FIG. 5. The setting of the cortical gel of the *Arbacia* egg, which occurs just prior to the appearance of the cleavage furrow. A, two unfertilized eggs, and B, a fertilized egg 5 minutes before cleavage time, all centrifuged together for 6 minutes at atmospheric pressure. The greater rigidity of the cortical gel of B is indicated by the fact that there has been scarcely any displacement of the pigment granules, which in this egg (*Arbacia pustulosa*) are localized entirely in the cortex. Note that the undisplaced pigment is readily observable in the cortical part of the hyaline zone.

from the temporary suppression, for the eggs continue to develop in an apparently normal fashion. They go through the second and third cleavage at the same time as control eggs, and give rise to blastulae which cannot be distinguished from untreated specimens.

(4) Effect of pressure on the rate of furrowing

In view of the marked effect of the relatively high pressure, it was of interest to determine how cleavage might be modified by lesser degrees of constraint. Soon it became apparent that lower

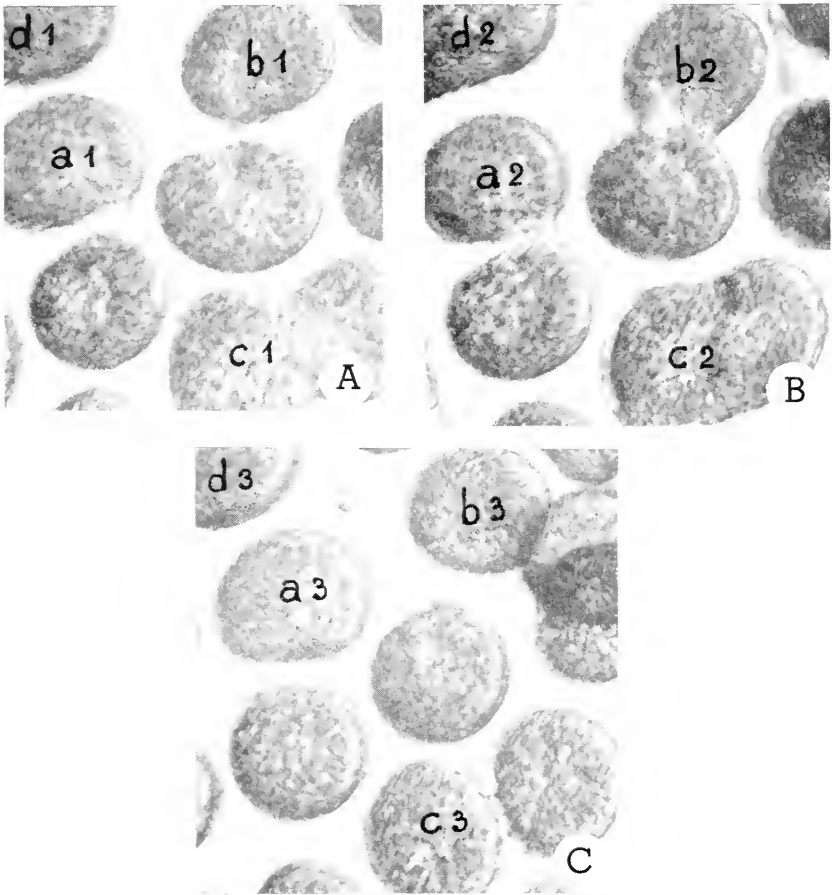

FIG. 6. Recession of the cleavage furrows as a result of hydrostatic compression. A, eggs (*Arbaeia punctulata*) 10 seconds after a pressure of 6,500 lbs./in.² was established in the chamber; B, two minutes later, pressure still maintained; C, two minutes after decompression, which occurred immediately after photograph B was taken. Note (b1 and b2) that recession of the furrow occurred even though the "blastomeres" were connected by a mere strand of protoplasm at the time when the pressure was applied. The fertilization membranes were removed shortly after the sperm was added.

pressures merely retard the rate at which the furrow intrudes upon the division axis, and a quantitative study of this effect was undertaken.

In these experiments the fertilized eggs were allowed to develop in the chamber at atmospheric pressure until 4 minutes before the

furrows were expected²⁶ to appear, at which time the pressure was raised quickly to the desired level. In order to time the progress of the intruding furrow accurately, it was found necessary to remove the fertilization membranes by shaking the eggs before placing them in the chamber. This procedure permits the dividing eggs to become more elongate in the direction of the division axis and enables one to see the furrows more plainly. In this way it is possible to determine precisely when the furrow begins to form and when it finally reaches the axis of the dividing cell.

As the pressure is increased there is a marked increase in the time required for the furrow to complete its passage from the equator to the axis. At 2,000 lbs./in.² the rate of progress of the furrow is only half the atmospheric rate,²⁷ whereas at 5,000 lbs. the progress is slowed to about one-fifth of the original rate. At pressures between 5,000 and 6,000 lbs., abortive furrows are formed which fail to reach the division axis before receding. Above 6,000 lbs. no furrows appear although the eggs do become slightly elongate at the time when cleavage is due.

When one plots the rate of furrowing as a function of pressure (Fig. 2), it becomes apparent that the retardation is in proportion to the solation effect which the pressure exerts upon protoplasmic gels generally. This would indicate an intimate relation between the mechanics of furrowing and the capacity of the plasmagel system to undergo a process of setting at the time when the furrowing is active. However, direct measurements of the pressure effect upon the exceptionally stiff gel which is formed at this critical time, remain for consideration.

(5) *Solution of the firm "cleavage gel"*

The eggs of *Arbacia pustulosa*, which are available at the Naples laboratory in adequate quantities throughout the year, were chosen for these experiments. These eggs possess an unusually generous number of pigment granules, and this pigment is confined, even in the unfertilized egg, almost entirely to the cortical layer of the cytoplasm. These two attributes are of particular advantage in the experiments.

Heretofore, it had not been possible, using centrifugal forces up to $7,200 \times$ gravity, and pressures up to 7,000 lbs./in.² (Brown, '34c), to cause any appreciable displacement of the pigment granules if the centrifuging were done late in the division cycle, i. e., within 10 minutes of the time when the furrows were due to appear. In

In the present experiments it was found necessary to use a force of $16,500 \times$ gravity to secure an adequately rapid displacement of the pigment granules through the firmly set plasmagel. But even this force is not sufficient to dislodge the granules except under the liquefying action of pressures greater than $1,500 \text{ lbs./in.}^2$ At atmospheric pressure, a force of $18,680 \times$ gravity, the highest immediately available at the Naples laboratory, gave practically no pigment displacement even with prolonged centrifugation.

The centrifugal force used in the experiments was $16,500 \times$ gravity, and each sample of eggs, compressed to the desired degree, was centrifuged for a period just sufficient to displace the cortical pigment into a compact zone at the centrifugal pole of the cell. In each case the eggs of a single female were fertilized and allowed to develop in the usual fashion until the first furrows began to appear. Then, without delay, the control and experimental samples were placed in their respective sections of the centrifuge-pressure bomb, and the desired pressure was established in the pressure section. The operations were so fixed that, at the time when the pressure was applied and the centrifuging begun, about 50 per cent of the eggs possessed furrows of greater or lesser depth.

The very marked solating action of the higher pressures upon the pigment-laden cortical protoplasm of the cleaving egg is clearly shown in Figure 7. All of these eggs were centrifuged at the same time for $2\frac{1}{2}$ minutes. It may be noted that each of the pressure-treated specimens displays, in addition to the usual oil, hyaline, and yolk zones, a sharp pigment zone, at the centrifugal pole. This zone is absent in the atmospheric specimens.²⁸ Also it may be noted that the one egg which had just completed the first cleavage by the time the suppressing action of the pressure could take effect displays the same physical properties as the others.

Assuming that the firmness (gelation percentage) of the cortical gel is in proportion to the minimum centrifuge time required to produce a standard zoning of the pigment granules, in the range of pressure wherein an effective displacement occurs, it is possible to plot the gelation values as a function of pressure. These data (Fig. 2) indicate, not only that the very firm plasmagel of the cleavage period shows the same relative susceptibility to the solating effects of pressure as other cellular gels, but also that the inhibition of furrowing is quantitatively related to the concomitant shifts in the sol \rightleftharpoons gel equilibrium.

D. BEHAVIOR OF UNICELLULAR PIGMENTARY EFFECTORS

Recently, experiments have been started to determine the effects of pressure upon the ebb and flow of pigment granules as it occurs in the melanophores of *Fundulus* (Marsland, '40). As yet the results are far from complete, but there are clear indications that

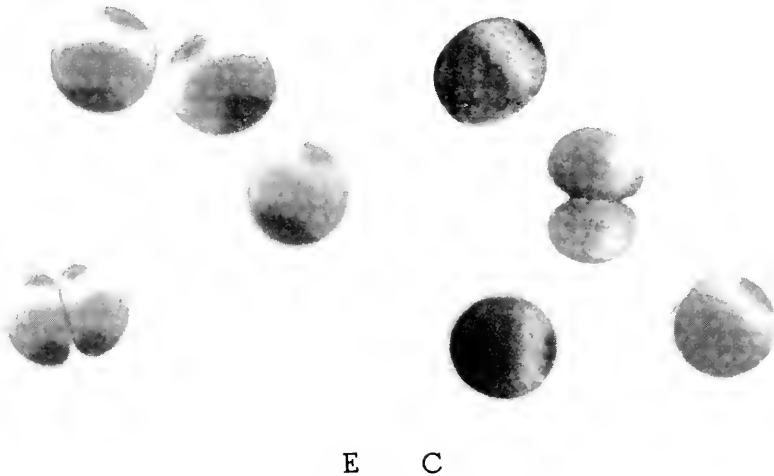

FIG. 7. Solution of the stiffer "cleavage gel" by pressure. All of these eggs were centrifuged simultaneously for 2.5 minutes at the time when 50 percent of them displayed furrows. The E (experimental) samples were at 7,000 lbs./in.², whereas the control (C) eggs were at atmospheric pressure. The solution of the cortical gel of the pressure specimens is indicated by the pigment zones at the centrifugal ends, and by the fact that all pigment has been thrown out of the hyaline zones.

this type of streaming may also involve gelational phenomena. These results, if borne out by further work, may provide a basis for deciding whether the unicellular pigmentary effector is to be regarded as a modification of visceral muscle (Spaeth, '16) or as an amoeboid type of cell (Hooker, '14).

(1) *Suppression of the "contraction" phase of the pigmentary response*

In this type of experiment the isolated scale of *Fundulus* was immersed in N/10 KCl solution and exposed to various degrees of compression in the microscope-pressure chamber. At atmospheric

pressure the scales in KCl assume the punctate form, that is to say, all of the pigment granules are withdrawn from the numerous twig-like branches which radiate out into the surrounding tissues, and are aggregated in the central mass of the cell. As the pressure is increased, however, by steps of 1,000 lbs., invariably there is a greater and greater dispersal of the pigment (see Fig. 8) until at

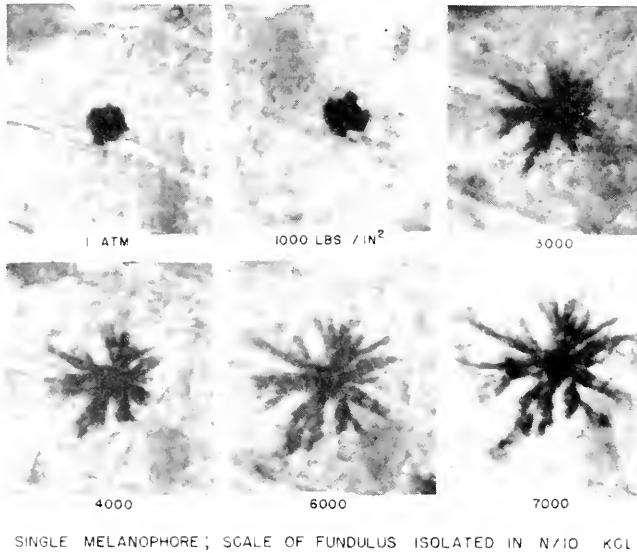

FIG. 8. Suppression of the "contraction" phase of the response of a unicellular chromatophore.

about 7,000 lbs. the pigment reaches the extremities of the protoplasmic branches and all of the melanophores have become completely stellate.

The "expansion" of the melanophore appears to reach an equilibrium value at each level of pressure, and if the pressure is kept at a certain intensity the melanophores remain expanded to the characteristic extent. This steady state is reached in 40–80 seconds after each shift in pressure, and is approximately the same whether a certain level is reached from above, during a step-wise decompression, or whether it is attained from below via step-wise increments of pressure. Furthermore, at a given pressure each cell returns

approximately to the same form when the experiment is repeated a number of times, provided the exposure to pressures in excess of 5,000 lbs. does not endure beyond about 20 minutes.

Quantitative measurements of the chromatophoral expansion as a function of pressure are difficult due to the extremely irregular form of the pigment cell, and at the present time only qualitative data are available. The same is true of centrifuging experiments which have been undertaken to determine the effects of pressure upon the gel properties of these cells. Without question solation does occur, but several technical difficulties must be overcome before accurate measurements can be made.

From a qualitative point of view, however, it would appear that the contraction phase of the pigmentary response is limited by pressure in a manner that parallels, at least roughly, the inhibition of gelation which has been demonstrated in plasmagel systems generally. It may be seen, for example, that the "half-expanded" state of the chromatophore which occurs at about 2,500 lbs./in.² corresponds to a gelation value of approximately 50 per cent, and it seems probable that the other values, when they become available, may likewise fall upon the general curve.

(2) *Effects on pulsating chromatophores*

In this other type of experiment the chromatophores were induced to pulsate by the method²⁹ of Spaeth, '16, before the isolated scales were placed in the pressure chamber and exposed to pressures of 1,000, 2,000, . . . 8,000 lbs./in.² Immediately it becomes apparent that the pressure imposes a limitation upon the "contraction phase" of the pulsation. At 1,000 lbs. the pulsations continue, but although the outward flow of the pigment granules is complete and reaches the distal extremities of the numerous protoplasmic branches, the inward flow is curtailed and a reversal of the direction of flow occurs before the end of the procession of granules returning from each branch quite reaches the control mass of the cell. At 2,000, 3,000, . . . 6,000 lbs./in.² a greater and greater reduction in the amplitude of the pulsations is witnessed, but the reduction is due entirely to a further and further curtailment of the inward flow, for the outward flow continues to reach the distal ends of the branches. Finally, at 7,000 lbs. all pulsations cease, and while the pressure is maintained, all of the melanophores remain in a fully expanded condition. When decompression occurs, however, provided it has not been delayed beyond some 25 minutes, the chromatophores immediately undergo

a complete and vigorous "contraction," and within about 3 minutes, full pulsations have been resumed.

(3) *Comparison between pseudopodia and the branches of a pigment cell*

One further observation may be added to the evidence which indicates that the effects of the pressure are being mediated through solational changes similar to those which have been demonstrated in other cases. At pressures of 7,000–8,000 lbs./in.² occasionally it may be seen that one of the several elongate protoplasmic processes which radiate out from a particular melanophore becomes pinched off, losing its connection with the central portion of the cell at a greater or lesser distance from the origin. Such isolated portions of the cell become rounded into a discrete mass while the higher pressure is maintained, but show abortive attempts at "expansion" and "contraction" when the pressure is reduced.

This observation indicates that the branches of the unicellular chromatophore are in a sense comparable to the pseudopodia of the amoeboid cell and that a reorganization of the elongate form may occur when a profound solation of the protoplasm is induced. The greater resistance in the case of the chromatophore may be due largely to the fact that its branches are not free, but rather extend out into the interstices between the other tissues (see Matthews, '31). Under such conditions, no doubt, the chromatophore branches receive additional support, from contact with (or attachments to) the surrounding cells, and this support is sufficient, in most cases, to prevent collapse even in periods of complete protoplasmic liquefaction.

IV. CELLULAR ACTIVITIES WHICH DO NOT INVOLVE

A very brief and fragmentary consideration of the many experiments which have dealt with the effects of pressure upon the physiological activity of muscle, nerve, cilia, and flagella may suffice to show that this group of phenomena must be considered in a separate category. The physiological activities which already have been considered at length display certain common attributes. All are progressively inhibited throughout the entire physiological range of pressure, and in all cases, the degree of inhibition appears to be in proportion to the suppressing action of pressure upon the formation of protoplasmic gels. In contrast to this, the physiological activities which remain for consideration are not inhibited, but rather are augmented in the lower portion of the pressure range, and furthermore, no clear relationship has been demonstrated between the

physiological effects and the effects of the pressure upon the physical characteristics of protoplasmic gel systems.

A. MUSCULAR CONTRACTION

The marked increase in the tension developed during a single isometric contraction³⁰ at pressures between 100 and 6,000 lbs./in.² was reported, first for cardiac muscle (Edwards and Cattell, '27) and then for skeletal muscle (Cattell and Edwards, '28). For cardiac muscle the maximum augmented tension is four to six times greater than the atmospheric value and occurs at about 6,000 lbs./in.² (Edwards and Cattell, '30). For skeletal muscle, however, the maximum additional tension is only 20–40 per cent greater than the atmospheric value and is reached at pressures between 2,000 and 4,000 lbs./in.² (Cattell and Edwards, '32).

The pressure effect on tension in both cardiac and skeletal muscle varies, however, markedly with temperature. In fact, a reversal of sign occurs, at 5–8° C. for cardiac muscle (auricular muscle of the turtle, Brown, '34a), and at 9–14° C. for striated muscle (sartorius muscle of the frog, Cattell and Edwards, '32). Below these critical points a depression of tension occurs throughout all of the physiological pressure range.

Brown ('36) has observed that the full measure of additional tension is obtained only when the period of compression antecedes the moment of stimulation, and that no extra tension is obtained unless the compression intervenes before the first one-eighth of the contraction has been completed (Fig. 9). In fact, when the period of compression is confined to the remaining seven-eighths of the contraction phase, the tension amounts to less than the atmospheric control value (Brown, '34b and '36).

B. CONDUCTION OF THE NERVE IMPULSE

Grundfest and Cattell ('35) have demonstrated clearly that the compression effects on the nerve impulse do not constitute a simple case of progressive inhibition. These observations, on the form and magnitude of the spike potential and on the rate of propagation, were recorded by means of a cathode ray oscillograph, utilizing grouped A fibres of the frog sciatic nerve, and in some cases, single fibres of a sciatic-peroneal preparation.

The effects of moderate compression (below 5,000–6,000 lbs./in.²)

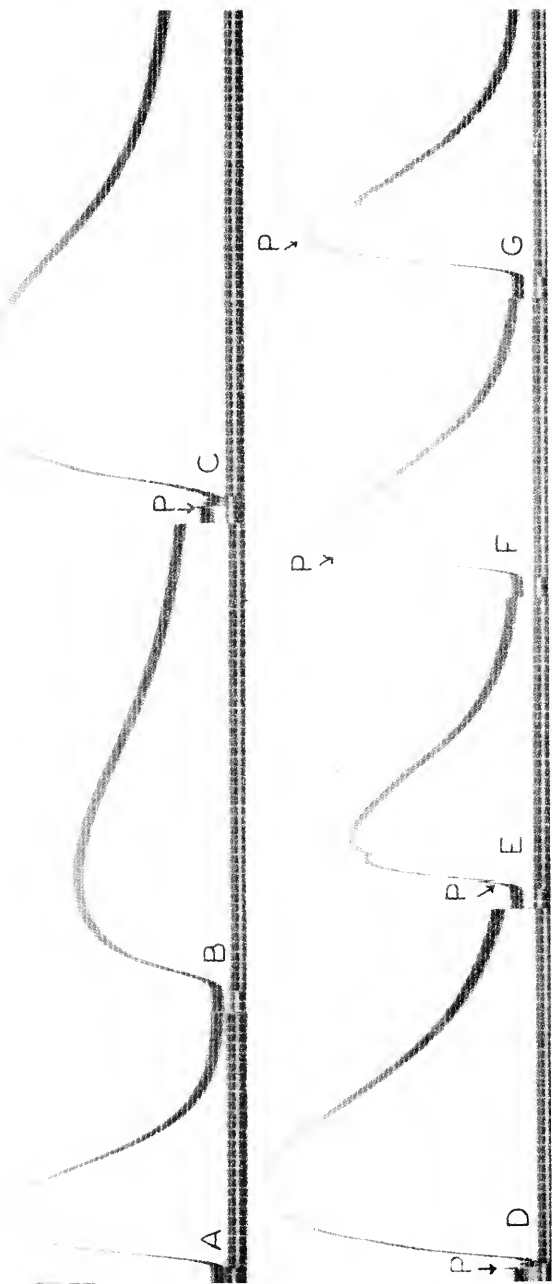

FIG. 9. (From Brown, '36, p. 147.) Myograms of the sartorius muscle of the frog illustrating the augmentation in tension induced by rapid compression to 204 atmospheres (3,000 lbs./in.²) at the onset of contraction, and the reduction in tension following a compression later in the contraction cycle. Myogram A recorded at atmospheric pressure. Myogram B recorded at 204 atmospheres after 15 seconds exposure to pressure. In Myogram C and the remaining records pressure is applied at the arrow, P. Time scale equals 0.04 seconds per division. Temperature 0.5°C.

are (1) an increase, up to about 10 per cent, in the height of the spike potential, (2) an increase, up to 20 per cent, in the duration of this potential, and (3) an increase, up to 12 per cent, in the rate at which the action potential is propagated. At pressures above 6,000 lbs. the height of the spike and the rate of propagation fall away, and at about 13,000 lbs. the nerve becomes practically non-responsive. However, the duration of the potential continues to increase throughout the higher range. At pressures above 5,000 lbs. it is also observed that a single short shock evokes not one, but several (up to four), discharges, even in the single fibre.

C. THE MOTILITY OF CILIA AND FLAGELLA

The work of Pease and Kitching ('36), on the influence of pressure on ciliary frequency in the gill filaments of the common mussel, *Mytilus edulis*, clearly demonstrates the accelerating effect of sudden increases in the pressure level, and the deceleration which occurs with each abrupt drop of pressure (see Fig. 10). In these experiments a stroboscopic method, accurate to the nearest 10 beats per minute, was used to measure the frequency of the ciliary beat.

It is interesting to note that, at least for moderate changes of compression, the frequency tends to return to the initial basic value, when the pressure is maintained at the higher or the lower level. When pressures above 5,000 lbs./in.² are maintained, however, after the initial burst of activity, the basic rate falls away rapidly, and within 10–15 minutes the cilia stop—an observation which is in agreement with the earlier studies of Regnard ('84 and '91) and of Certes ('84).

Pease and Kitching find no parallel between the changes of frequency and the known effects of pressure upon protoplasmic gel systems. They do, however, point out the striking similarity between the ciliary frequency effects and the cardiac frequency results obtained by Edwards and Cattell ('28).

Quantitative studies dealing with pressure effects on the motility of flagella are entirely lacking, and the qualitative observations which have been made are very fragmentary. However, it seems safe to say that this type of movement is even less susceptible than the ciliary type to inhibition by pressures within the range of reversible action. For example, Marsland and Brown observed in a cinematographic record of the action of pressure upon amoeboid movement that the motility of a few small flagellates, which inad-

vertently had been included with the Amoeba in the pressure chamber, continued without any sign of abatement while the pressure was maintained at 7,000 lbs./in.² for a period of about half an hour. Also, Marsland and Rugh ('40) could observe no change in

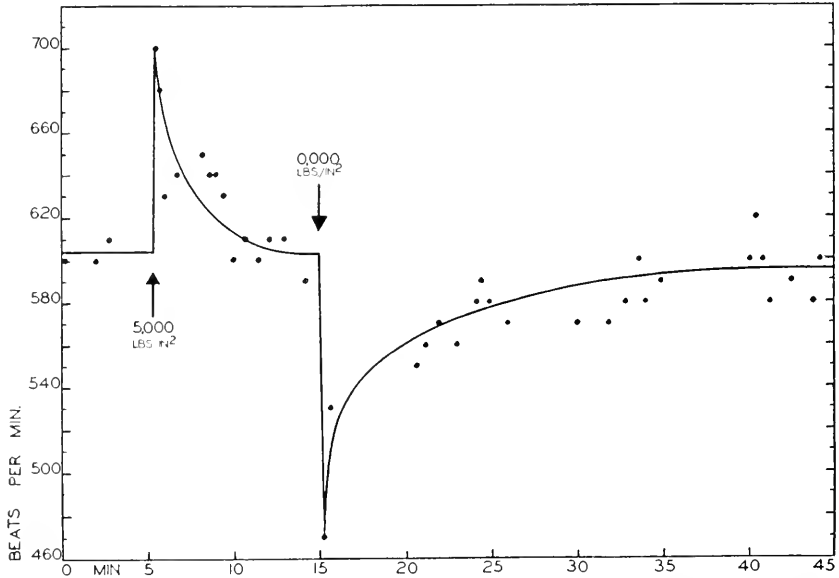

FIG. 10. (From Pease, '39, p. 137.) A single complete record of changes in the ciliary rate with rapid pressure changes of 5,000 lbs./in.²

the motility of sperm (*Rana pipiens*) during a compression period of 3 hours at 8,000 lbs./in.²

V. GENERAL DISCUSSION

A. NATURE OF THE PRESSURE EFFECT ON GEL STRUCTURE

One important question which must be raised is whether the influence of pressure on protoplasmic gel systems is a direct action upon the sol \rightleftharpoons gel equilibrium itself, or whether the direct action may be upon some other of the metabolic equilibria in the cell, which in turn may mediate the effect upon the gel system.

At the present time it would seem that the weight of evidence favors the direct action view. Freundlich ('37), on the basis of work by Heyman ('35 and '36), points out that gel equilibria fall into three categories, according to volume changes³¹ which accompany the setting of the gel. In the first type, which is exemplified by

sodium oleate and other *purely* thixotropic gels, no change of volume occurs when gelation or solation occurs at a fixed temperature, and the shift of equilibrium which is induced by periods of shaking or rest, is isothermal. The second type, exemplified by gelation or agar gels, displays a small decrease of volume with setting, and heat is evolved in the process. Finally, the third type, which is represented by colloidal aqueous solutions of methylcellulose, shows a small increase of volume and an absorption of heat during the setting process. Thus it is found that gels of the second type tend to set upon cooling, whereas those of the third type undergo solation as the temperature falls.

From the principle of Le Chatelier, it appears certain that hydrostatic pressure would favor solation in the third type of gel, gelation in the second type, and little or no change in the first. And the experimental evidence in this regard, although scanty, clearly substantiates the predictions. Thus Marsland and Brown ('39) have found that gelatin sols, which are known to belong in the second category, undergo marked gelation at pressures in the physiological range, whereas gel preparations of myosin extracted from rabbit muscle are solated to a degree which corresponds, at least in qualitative fashion, with the solational effects of pressure on protoplasmic gels.

In all probability, therefore, the various protoplasmic gels which have proved so susceptible to solation under pressure, belong to Freundlich's group III. This viewpoint is borne out by the truly remarkable regularity of the effect in different systems—for in every case which has been studied, each unit increment of pressure produces the same proportionate loss in the tensile properties of the gel which is being tested. If these changes were being effected indirectly through the medium of other chemical reactions, such a degree of regularity would scarcely be expected in so many different kinds of cell. Furthermore, it has been observed (Costello, '34) that the cortical gel of the *Arbacia* egg becomes less "viscous" as the temperature falls, a behavior which would not be expected unless this gel is of the third type.

The common component upon which the pressure acts in the various cells probably will prove to be one or more groups of protein substances which is capable of forming gels of the nature of type III. And in this connection it is interesting to note that Mirsky ('36) has extracted from the *Arbacia* egg (a cell which very plainly shows the characteristic pressure-solation effect) a protein

substance which closely resembles myosin with reference to its general chemical properties.

One cannot overlook the fact, however, that pressure also may induce marked changes in other types of metabolic reactions in the cell. Fontaine ('28), for example, reports increased oxygen consumption in a number of small marine animals exposed to pressure in the range up to about 1,500 lbs./in.² and Deuticke and Ebbecke ('37) describe a greatly accelerated breakdown of phosphocreatin and an increased lactic acid production in frog skeletal muscle during a short period of tetanic contraction at 8,000 lbs. Furthermore, it is well known that a great variety of organic reactions are markedly affected as to rate, and as to the point of equilibrium, by pressures within and beyond the physiological range (see, for example, Fawcett and Gibson, '34).

B. RELATION BETWEEN GELATION AND THE PHYSIOLOGICAL RESPONSE

In seeking fundamental factors which may explain why in one group of physiological activities (amoeboid movement, cyclosis, cell division, and pigmentary responses) the inhibition imposed by pressure is continuously in proportion to solation throughout all of the pressure range, whereas this is not the case for a second group (contraction of muscle, conduction of nerve, and the motility of cilia and flagella), two questions may be raised. (1) Is it true, perhaps, that gelation reactions are directly concerned in the development of the mechanical energy in the first group of responses but are not concerned, at least directly, in the second; or (2) is it possible that gelation reactions are involved in both cases but that the metabolic reactions which precede the active response and provide energy for it are relatively immune to augmentation by pressure in the first group, but not immune in the second?

An affirmative answer to the first question would provide the basis for a simpler working hypothesis. However, the data of Brown ('34b and '36), which indicate that augmented tension in muscle depends upon a greater mobilization of energy prior to the actual contraction and that the contractile process itself is actually depressed even by relatively low pressure, make it doubtful that this more restricted view is entirely tenable. In any event, however, in view of the accumulated data, one can scarcely avoid the conclusion that gelation reactions are directly concerned in the development of mechanical energy, at least in one group of physiological

activities, the group in which protoplasmic streaming constitutes the common attribute.

C. POSSIBLE MECHANISMS BY WHICH GELATION MAY PRODUCE STREAMING

(1) *Volume changes in relation to streaming*

In an earlier paper (Marsland and Brown, '36) it was suggested that the motive force of streaming in the amoeboid cell might take origin in the small changes of volume which occur during the gelation and solation of the cytoplasm. This position now seems untenable in the light of Heyman's ('35 and '36) work. In all probability the sign of these changes is in reverse, that is to say, just the opposite kind of volume changes would be necessary to give streaming in the proper direction. The decrements of volume would need to occur anteriorly, near the tip of the pseudopodium, where gelation is known to be taking place, and the increments of volume would need to be localized posteriorly where solation is occurring. To provide volume changes of the proper sign, the plasmagel of the *Amoeba* would of necessity belong to Freundlich's type II, but in this case one would expect to obtain gelational effects from pressure, instead of the solation which has clearly been demonstrated.

In the streaming of plant cells, however, the possibility still remains that volume changes accompanying a series of sol \rightleftharpoons gel reactions play an important role in generating the motive force (Marsland, '39b), but the question cannot be answered decisively until the focal points where solation and gelation take place have been localized more definitely. The high turgor which is characteristic of the plant cell provides a favorable condition for the effectiveness of such changes, since a greater fund of energy is mobilized when volume changes take place in a medium under the constraint of higher pressure.

(2) *Contractile theories of streaming*

According to Lewis ('39) streaming in amoeboid cells³² and the movements which occur in dividing cells are motivated by elastic and contractile properties which are inherent in gel structures generally, and in the plasmagel systems of certain cells in particular. Given time, most gels do, of course, undergo a process of contraction by which gradually the sol is squeezed forth from the colloidal interstices into the surrounding medium, as, for example, serum is expressed from a blood clot, or soap solution from a soap gel.

Such a theory presupposes, no doubt, that shrinkage in the

animate gel is accelerated by metabolic conditions established in the cell, and also that these metabolic conditions create differences in the contractile force in different parts of the plasmagel system. In an *Amoeba*, for example, there would need to be a gradient such that the contractile properties are greater in the older posterior parts of the plasmagel than in the more recently formed anterior parts of the system. In addition to the descriptive evidence for such a gradient, which is provided by the work of Mast and of Lewis, the pressure experiments of Marsland and Brown indicate a distinctly lesser rigidity in plasmagel walls near the extremities of the pseudopodia, and a loss of this property would indicate, no doubt, a lesser contractile potentiality.

An extension of the quantitation data yielded by the recent experiments of Noburo Kamiya ('40) and of Norris ('40) may, perhaps, provide a basis for deciding whether or not the elastic contractile forces generated in a plasmagel system are adequate to account for the vigor of the streaming. Fortunately both of these workers are using the same organism, one of the myxomycetes, *Physarum polycephalum*. The ingenious method of Kamiya appears to give very accurate measurements of the flow pressures which are developed as the protoplasm streams back and forth in the channel between two parts of the plasmodium, and it is to be hoped that Norris' technique of determining the elastic properties of the gel system can be adapted to measure the changes of tension which must occur concomitantly with the rhythmic alternations in the direction of flow.

The viewpoint expressed by Seifriz ('37) represents somewhat of a departure from the ideas of Lewis and Mast. Time-lapse motion pictures enabled Seifriz to demonstrate very plainly that each portion of the plasmodium of the slime mold displays alternating periods of expansion and contraction and led him to believe that these pulsations are analogous to the rhythmic beating of visceral muscle as controlled by the autonomic nervous system. Fundamentally, perhaps, there may be little difference between the two viewpoints, for in the last analysis it may be that the same forces are involved in the setting and contraction of certain gels and the contractile processes in the myofibrillae. If this be true, the marked differences, in regard to the consequences of hydrostatic compression, between muscle cells and cells which are characterized by protoplasmic streaming, are due to more superficial factors, as for

example, differences in the metabolic reactions which are precursory to the development of the mechanical energy.

VI. SUMMARY OF CONCLUSIONS

(1) The general effect of hydrostatic compression upon a number of different cells is to induce a uniform solution of gelled parts (the plasmagel system) of the protoplasm. Each increment of 1,000 lbs./in.² reduces the gel rigidity by almost 25 per cent.

(2) All of the protoplasmic gels which have been studied appear to conform to the type (Freundlich, '37) in which the process of gelation is accompanied by a small increase of volume.

(3) Certain types of cellular movement (amoeboid movement, cyclosis, cell division, and the flow of pigment in unicellular pigmentary effectors), in which protoplasmic streaming is the common attribute, are especially susceptible to a pressure-induced inhibition. In contrast, other physiological activities (muscular contraction, nervous conduction, and the motility of cilia and flagella) are augmented by low and moderate degrees of pressure and suffer depression only in the higher range (above 5,000 lbs./in.²).

(4) The inhibiting effect of pressure upon the various kinds of protoplasmic streaming is in proportion to the degree of solution which the pressure induces in the plasmagel systems.

(5) To interpret these results, it is postulated that $\text{sol} \rightleftharpoons \text{gel}$ reactions constitute an intermediary mechanism whereby potential energy is converted by the cell into mechanical energy—the mechanical energy of the streaming protoplasm.

FOOTNOTES

¹ Brown ('34c), Marsland ('38 and '39), Pease and Marsland ('39).

² Brown and Marsland ('36).

³ Kitching and Pease ('39).

⁴ Ebbecke ('36).

⁵ Marsland ('39b).

⁶ Pease ('40b).

⁷ Judging from the compressibility of muscle tissue (see Cattell, '36, p. 458), the loss of protoplasmic volume in the range of pressure used in the present experiments, would be about 2 per cent.

⁸ Previous microscope-pressure chambers permitted observation of the compressed specimens, but at much lower magnification (see, for example, Draper and Edwards, '32).

⁹ Leitz, U. M.

¹⁰ This amount of working distance is necessary since the walls of the chamber must be thick enough to support the high internal pressure.

¹¹ Reorganization of a fluid cylinder into drops will occur when the length exceeds π times the diameter, provided the viscous (or plastic) resistance of the material is not too great.

¹² This assumption seems fully justified from measurements on a variety of cells. Each pressure increment induces the same percentage degree of solation regardless of the absolute initial rigidity of the particular gel.

¹³ These values frequently have been referred to as the relative viscosity of the protoplasm. This term, however, fails to distinguish between measurements dealing with solated, and those made upon gelled parts of the system. Furthermore, in a truly viscous system some displacement of suspended granules occurs even under very low centrifugal forces, which is not the case in the present measurements.

¹⁴ At constant centrifugal force, namely $7,000 \times$ gravity.

¹⁵ The elongation of the pseudopodia which occurs at pressures below 2,000 lbs. is probably related to the observation that in this range no plasmagel-sheet (Mast, '26) is present at the pseudopodial tips. Apparently this part of the plasmagel system, which tends to restrain the outflow of the plasmasol, and which constitutes a gelation focus when retraction is to begin, is more labile than the other parts.

¹⁶ Recently, Pease ('40) describes an acceleration of streaming in the plasmodium of the slime mold (*Physarum polycephalum*) at pressures between 1,000 and 3,000 lbs./in.² This would constitute an exception to the general rule that protoplasmic streaming is progressively inhibited by pressure in the physiological range. Perhaps the discrepancy may be explained on the basis that in *Physarum* the whole plasmodium suffers reorganization in the range. The acceleration may indicate that, as the contours of the protoplasmic mass are changing, surface forces become active to augment the flow. This interpretation is favored by the observation that the accelerated flow occurs chiefly in plasmodia which are not attached to the substratum but which are freely suspended in the medium. A further factor in the acceleration may be found in the reorganization which occurs in the channel walls. Thus the flow in a particular channel might be augmented as a result of an anastomosis from a neighboring channel. To obtain quantitative data in this connection, perhaps the technique of Kamiya ('40) could be used.

¹⁷ As for example, when streaming is about to stop, or when it is barely beginning. At such times the channels and the direction of flow may be highly irregular.

¹⁸ At constant centrifugal force. In the case of *Elodea* this was $810 \times$ gravity.

¹⁹ Recent work by Pease (personal communication) indicated that sol \rightleftharpoons gel reactions may also be important in the migration of the chromosomes during anaphase.

²⁰ The use of the terms plasmagel and plasmasol with reference to the cytoplasm of egg cells was first proposed by Marsland ('39a).

²¹ It is possible that the plasmagel system of the egg cell also includes some of the medullary cytoplasm such as parts of the spindle and asters.

²² This observation is recorded in one of Dr. Chambers' cinema films. See also Chambers ('38).

²³ The eggs of *Arbacia punctulata* were used in the study of the visible effects of pressure upon cleavage, whereas those of *Arbacia pustulosa* served for the measurements of the solation effects.

²⁴ In from 1-10 minutes, depending upon the depth to which the furrow has gone, and upon the intensity (above 7,000 lbs.) of the pressure.

²⁵ Apparently the internal conditions which result in cleavage persist for a limited time (about 15 minutes at 22° C.). If the experimental inhibition is prolonged beyond this, the tendency to cleave lies dormant until control eggs have just begun the second cleavage. Now the eggs in which the "first" cleavage has been suppressed, also begin to cleave, usually into four blastomeres directly,

although a few three-cell and two-cell specimens may appear. Later, a number of these embryos fail to gastrulate normally.

²⁶The data of Fry ('36) were very useful in determining the schedule. The eggs of most females start to cleave as follows: at 21° C., in 60 min.; at 22°, in 52 min.; and at 23°, in 47 min.

²⁷At 23° C. complete furrowing at atmospheric pressure requires an average time of 3.1 min., in contrast to the 6.2 min. required at 2,000 lbs. in.²

²⁸The lesser sharpness of the oil, hyaline, and yolk zones in the atmospheric specimens represents an illusion due to the fact that they are seen through the layer of undisplaced pigment. Sharp focussing shows that actually these zones are quite equal in the atmospheric and the pressure specimens.

²⁹The isolated scales are immersed, first in N 10 NaCl for 15 min., and then in N 10 BaCl₂ for 7 min. When returned to the sodium chloride solution, pulsations begin in about 45 min. and continue for 2 hrs. or more.

³⁰Only the pressure effects upon tension in the single twitch will be considered in this paper. In other words, none of the work on tetanic contractions, or upon contractures, will be included.

³¹In these volume experiments, Heyman used a very sensitive dilatometer, kept constant to 0.003° C. The capillary which served to measure the volume change was very fine, and a 1-cm. excursion of the meniscus corresponded to a volume change of 0.0016 cc.; and since the complete volume of the sol which was turning to a gel was 80 cc., a change of volume amounting to 0.0002 per cent could be measured very accurately.

³²See also papers by S. O. Mast (e. g., '26 and '31) and the paper by W. H. Lewis in the present monograph.

LITERATURE CITED

- BROWN, D. E. S. 1934a. The pressure-tension-temperature relation in cardiac muscle. *Amer. Jour. Physiol.*, vol. 109, p. 16.
- . 1934b. The effect of rapid changes in hydrostatic pressure upon the contraction of skeletal muscle. *Jour. Cell. and Comp. Physiol.*, vol. 4, page 257.
- . 1934c. The pressure coefficient of "viscosity" in the eggs of *Arbacia punctulata*. *Jour. Cell. and Comp. Physiol.*, vol. 5, p. 335.
- . 1936. The effect of rapid compression upon the events in the isometric contraction of skeletal muscle. *Jour. Cell. and Comp. Physiol.*, vol. 8, p. 141.
- BROWN, D. E. S., AND D. A. MARSLAND. 1936. The viscosity of *Amoeba* at high hydrostatic pressure. *Jour. Cell. and Comp. Physiol.*, vol. 8, p. 159.
- CATTELL, M. 1936. The physiological effects of pressure. *Biol. Rev.*, vol. 11, p. 441.
- CATTELL, McK., AND D. J. EDWARDS. 1928. The energy changes of skeletal muscle accompanying contraction under high pressure. *Amer. Jour. Physiol.*, vol. 86, p. 371.
- AND ————. 1932. Conditions modifying the influence of hydrostatic pressure on striated muscle with special reference to the role of viscosity changes. *Jour. Cell. and Comp. Physiol.*, vol. 1, p. 11.
- CERTES, A. 1884. Note relative à l'action des hautes pressions sur la vitalité des micro-organismes d'eau douce et d'eau de mer. *C. R. Soc. Biol., Paris*, T. 36, p. 22.
- CHAMBERS, R. 1938. Structural and kinetic aspects of cell division. *Jour. Cell and Comp. Physiol.*, vol. 12, p. 149.
- COSTELLO, D. P. 1934. The effects of temperature on the viscosity of *Arbacia* egg protoplasm. *Jour. Cell. and Comp. Physiol.*, vol. 4, p. 421.
- DAN, K., T. YANAGITA, AND M. SUGIYAMA. 1937. Behavior of the cell surface during cleavage. *Protoplasma*, Bd. 28, S. 66.

- DEUTICKE, H. J., AND U. EBEBECKE. 1937. Über die chemischen Vorgänge bei der Kompressionsverkürzung des Muskels. *Hoppe-Seyler's Zeitschr. physiol. chem.*, vol. 247, p. 79.
- DRAPER, J. W., AND D. J. EDWARDS. 1932. Some effects of high pressure on developing marine forms. *Biol. Bul.*, vol. 63, p. 99.
- EBEBECKE, U. 1936. Über plasmatische Kontraktionen von roten Blutkörperchen, Paramäcien, und Algenzellen unter der Einwirkung hoher Drucke. *Pflüg. Arch. ges. Physiol.*, B 238, z. 452.
- EDWARDS, D. J., AND McKEEN CATTELL. 1927. Some results of the application of high pressures to the heart. *Proc. Soc. Exp. Biol. and Med.*, vol. 25, p. 234.
- AND ———. 1928. The stimulating action of hydrostatic pressure on cardiac function. *Amer. Jour. Physiol.*, vol. 84, p. 472.
- AND ———. 1930. The action of compression on the contraction of heart muscle. *Amer. Jour. Physiol.*, vol. 93, p. 90.
- F'AWCETT, E. W., AND R. O. GIBSON. 1934. The influence of pressure on a number of organic reactions in the liquid phase. *Jour. Chem. Soc., Part I*, p. 386.
- FONTAINE, M. 1928. Les fortes pressions et la consommation d'oxygene de quelques animaux marins. *C. R. Soc. Biol.*, T. 99, p. 1789.
- . 1929. De l'action des fortes pressions sur les cellules vegetales. *C. R. Soc. Biol.*, T. 101, p. 452.
- FREUNDLICH, H. 1937. Some recent work on gels. *Jour. Phys. Chem.*, vol. 41, p. 901.
- FRY, H. J. 1936. Studies of the mitotic figure. V. The time schedule of the mitotic changes in developing *Arbacia* eggs. *Biol. Bul.*, vol. 70, p. 89.
- GRUNDFAST, H., AND McK. CATTELL. 1935. Some effects of hydrostatic pressure on nerve action potentials. *Amer. Jour. Physiol.*, vol. 113, p. 56.
- HEILBRUNN, L. V. 1929. The absolute viscosity of *Amoeba* protoplasm. *Protoplasma*, vol. 8, p. 65.
- HEYMAN, E. 1935. Studies on sol \rightleftharpoons gel transformation. I. Inverse sol \rightleftharpoons gel transformation of methyl-cellulose in water. *Trans. Farad. Soc.*, vol. 31, p. 846.
- . 1936. Studies on sol \rightleftharpoons gel transformation. II. Delatometric investigations on iron hydroxide, gelatin, methylcellulose, silicic acid and viscose. *Trans. Farad. Soc.*, vol. 32, p. 462.
- HOOKE, D. 1914. Amoeboid movement in the corial melanophores of frogs. *Anat. Rec.*, vol. 8, p. 103.
- KAMIYA, N. 1940. The control of protoplasmic streaming. *Science*, vol. 92, p. 462.
- KITCHING, J. A., AND D. C. PEASE. 1939. The liquefaction of the tentacle of suctorian protozoa at high hydrostatic pressures. *Jour. Cell. and Comp. Physiol.*, vol. 14 (supplement of No. 3), p. 1.
- LEWIS, W. H. 1939. The role of a superficial plasmagel layer in changes of form, locomotion and division of cells in tissue cultures. *Arch. Exp'l. Zellforsch. Gewebzücht.*, vol. 23, p. 1.
- MARSLAND, D. A. 1936. The cleavage of *Arbacia* eggs under hydrostatic compression. *Anat. Rec.*, vol. 67, p. 38 (supplement).
- . 1938. The effects of high hydrostatic pressure upon cell division in *Arbacia* eggs. *Jour. Cell. and Comp. Physiol.*, vol. 12, p. 57.
- . 1939a. The mechanism of cell division. Hydrostatic pressure effects upon dividing egg cells. *Jour. Cell. and Comp. Physiol.*, vol. 13, p. 15.
- . 1939b. The mechanism of protoplasmic streaming. The effects of high hydrostatic pressure upon cyclosis in *Elodea canadensis*. *Jour. Cell. and Comp. Physiol.*, vol. 13, p. 23.

- . 1940. The effects of high hydrostatic pressure on the melanophores of the isolated scales of *Fundulus heteroclitus*. *Anat. Rec.*, vol. 78, p. 168 (supplement).
- MARSLAND, D. A., AND D. E. S. BROWN. 1936. Amoeboid movement at high hydrostatic pressure. *Jour. Cell. and Comp. Physiol.*, vol. 8, p. 167.
- AND ————. 1939. The effects of hydrostatic pressure upon gelation phenomena in animate and inanimate systems. *Anat. Rec.*, vol. 75, p. 141 (supplement).
- AND R. RUGH. 1940. Resistance of sperm of *Rana pipiens* to hydrostatic compressions; effect upon embryonic development. *Proc. Soc. Exp. Biol. and Med.*, vol. 43, p. 141.
- MAST, S. O. 1926. Structure, movement, locomotion, and stimulation in *Amoeba*. *Jour. Morph. and Physiol.*, vol. 41, p. 347.
- . 1931. Locomotion in *Amoeba proteus* (Leidy). *Protoplasma*, vol. 14, p. 321.
- MATTHEWS, S. A. 1931. Observations on pigment migration within the fish melanophore. *Jour. Exp. Zool.*, vol. 58, p. 471.
- MIRSKY, A. E. 1936. Protein coagulation as a result of fertilization. *Science*, vol. 84, p. 333.
- MOTOMURA, I. 1935. Determination of the embryonic axis in the eggs of Amphibia and Echinoderms. *Sci. Reports of the Tohoku Imp. Univ.*, 4th series, vol. 10, p. 212.
- NORRIS, C. H. 1940. Elasticity studies on the Myxomycete, *Physarum polycephalum*. *Jour. Cell. and Comp. Physiol.*, vol. 16, p. 313.
- PEASE, D. C. 1940a. The effects of hydrostatic pressure upon the polar lobe and cleavage pattern in the *Chaetopterus* egg. *Biol. Bul.*, vol. 78, p. 103.
- . 1940b. Hydrostatic pressure effects upon protoplasmic streaming in plasmodium. *Jour. Cell. and Comp. Physiol.*, vol. 16, p. 361.
- AND J. A. KITCHING. 1939. The influence of hydrostatic pressure upon ciliary frequency. *Jour. Cell. and Comp. Physiol.*, vol. 14, p. 135.
- AND D. A. MARSLAND. 1939. The cleavage of *Ascaris* eggs under exceptionally high pressure. *Jour. Cell. and Comp. Physiol.*, vol. 14 (supplement of No. 3), p. 1.
- REGNARD, P. 1884. Note relative à l'action des hautes pressions sur quelques phénomènes vitaux (mouvement ces cils vibratiles, fermentation). *C. R. Soc. Biol.*, Paris, T. 36, p. 187.
- . 1891. Recherches expérimentales sur les conditions physiques de la vie dans les eaux. Masson, Paris.
- SCHECHELTMAN, A. M. 1937. Localized cortical growth as the immediate cause of cell division. *Science*, vol. 85, p. 222.
- SEIFRIZ, W. 1937. A theory of protoplasmic streaming. *Science*, vol. 86, p. 397.
- SPAETH, R. A. 1916. Evidence proving the melanophore to be a disguised type of smooth muscle cell. *Jour. Exp. Zool.*, vol. 20, p. 193.



THE RELATION OF THE VISCOSITY CHANGES OF PROTOPLASM TO AMEBOID LOCOMOTION AND CELL DIVISION¹

WARREN H. LEWIS

The Wistar Institute of Anatomy and Biology

The viscosity of protoplasm is often readily changeable from sol to gel, gel to sol, and to various intermediate states by unknown internal factors and a few known external ones. The contractile tension which protoplasm exerts varies more or less with its viscosity. The contractile tensions exerted by protoplasm play important roles in the activities of cells and organisms, some of which are to be considered in the following pages.

AMEBOID LOCOMOTION

The essential aspects of ameboid locomotion have been presented by Mast in his classical account of the structure and locomotion of the ameba.

Contraction of the posterior part of the superficial gel layer or plasmogel drives the less viscous endoplasm, plasmosol, forward through the body of the cell or organism into the softened or weakened anterior end and there produces advancing pseudopods. As the posterior part of the gel layer contracts and shortens, some of it solates or becomes less viscous, mixes with and is carried forward in the endoplasm. At the anterior end, the endoplasm which reaches the lateral walls of the pseudopod gels and gradually extends or builds up the body forward as rapidly as it is torn down at the posterior end. A substratum is needed to move on. This generalized statement applies to the ameba, to the slime mold, to leucocytes, to different types of normal and malignant cells that migrate in tissue cultures, and with certain special modifications probably to all types of organisms and cells which have not developed specialized organs of locomotion such as cilia, flagella, undulatory membranes, and muscles.

The superficial gel layer is the motor organ in the ameboid type of locomotion. The contractile tension which protoplasm exerts

¹ Aided by a grant from the International Cancer Research Foundation.

when it is in the gel state is the key to this, and probably also to the action of cilia, flagella, undulatory membranes, and muscles.

Ameboid locomotion thus depends (a) upon a definite organization of the cell or organism, namely, a superficial gel or viscous layer and a central less viscous or fluid endoplasm, (b) upon the contractile tension which protoplasm (a colloid) automatically exerts when it gels, (c) upon local changes of viscosity: gel layer into fluid or semifluid endoplasm, and endoplasm into gel layer, (d) upon the regulation and the polarization of the viscosity changes, and (e) upon a substratum.

Ameboid type of locomotion depends upon a *definite organization* of the cell or organism, namely, a superficial gel layer and a central less viscous or fluid endoplasm. The necessity for this particular type of organization is evident if one considers any other hypothetical type of organization. If gelation were central or immediately about the central area and the nucleus and the fluid or less viscous protoplasm superficial, ameboid locomotion would be impossible. A uniform viscosity of the protoplasm from surface to center throughout the organism or cell, whether in the sol, the gel, or a semigel state would also preclude ameboid locomotion.

Other important aspects of this organization are (a) the relative and the absolute thickness of the gel layer and the endoplasm and (b) the relative and absolute viscosity of the two layers. The thickness and viscosity undoubtedly vary from moment to moment in active cells and protozoa, less rapidly in inactive ones. They also vary with the type and metabolic condition of the cell and the organism.

The factors which bring about this fundamental type of organization are unknown. Probably all cells and protozoa have either permanently or temporarily this type of organization, even though they do not migrate (plant cells and eggs, for example) or migrate with the aid of special organs such as cilia, etc. All cells and protozoa are derived from cells or protozoa that multiply by cleavage, and cleavage, as will be shown later, is dependent upon the gel layer. Some types of cells become much modified and lose their power to divide. Among them there may be some that lose this general type of organization. Any theory that attempts to explain the factors involved which produce this fundamental type of organization will probably be applicable to all cells and to protozoa. Heilbrunn (1940) has a theory that the high viscosity of the cortex (gel layer) depends on the presence of the calcium ion, and that the

low viscosity of the interior of the living cell is due to the absence or scarcity of free calcium. Various other theories might be suggested, such as increase in the acidity or of the CO_2 at the surface. Jacobs (1922, p. 29) states, "A short exposure to carbon dioxide of various cells causes a decrease, and a longer exposure an increase in the viscosity of the protoplasm. It is suggested that carbon dioxide may be an important factor in producing many of the natural changes in protoplasmic consistency which have hitherto been unexplained."

We come now to our second important factor in ameboid locomotion, namely, the *contractile tension* which protoplasm (a colloid) automatically exerts when it gels. This is a phenomenon common to living and many nonliving colloids such as blood plasma, gelatin, and silica gel. Some colloids exert enough tension when they gel to flake off glass from the wall of the containing vessel. Mast (1926, 1931) believes that the contractile tension is due to an elastic recoil. He states (1926, p. 404) that "there is an abundance of evidence indicating that the plasmagel and the plasmalemma are elastic and that they are usually somewhat stretched and consequently exert inward pressure; that is, that amebae are usually turgid" (1926, p. 405). "The fact that amebae are usually turgid indicates that the plasmagel, and possibly also the plasmalemma, is semipermeable and that the plasmasol, and probably also the substance in the vacuoles in the plasmagel, is hypertonic. If this obtains, it is plain that there would be an excess inflow of water and a stretching of the plasmagel and the plasmalemma until their combined strength equals the diffusion pressure." (1931, p. 330) "An ameba is a turgid system; owing to this the plasmagel is continuously under tension. The plasmagel is elastic and consequently is pushed out at the region where its elastic strength is lowest. This results in the formation of pseudopods."

My idea of the origin of the contractile tension of the gel layer differs from that of Mast. He assumes that the plasmogel is elastic and that it is stretched by the inflow of water into the plasmosol. In this stretched condition it keeps the ameba turgid and drives the plasmosol into the weakened areas to form pseudopods. My idea is that protoplasm, like most colloids, automatically exerts contractile tension when it gels (Lewis, 1939).

I was led to adopt this view because Mast's theory did not seem to offer an adequate explanation for the occurrence of constriction rings. For example (Lewis, 1939, p. 415), "The contorted mitoses observed in the division of the spindle cells of the spindle-cell

sarcoma C37 are explained by the development of changing contraction bands of the plasmagel layer which produce constrictions that result in marked distortions and lobulations of the dividing and young daughter cells." During anaphase, telophase, and early daughter cell stages (Lewis, 1939, p. 409), "Constrictions appear and disappear in different regions, squeezing the cells into lobulated and elongated forms." Constriction rings appear regularly on migrating lymphocytes and neutrophils, occasionally on fibroblasts and sarcoma cells, and always in cell cleavage (Lewis, 1939). It is impossible to see how an elastic recoil theory can explain such constrictions. It is difficult to explain the retractions of cell processes and pseudopodia on the elastic recoil theory or the retraction of gel sheets and gel strands of the slime mold that are far away from the streaming endoplasm, or the excessive contraction of an ameba that squeezes out all the endoplasm through a break in the plasmogel and plasmolemma.

Presumably the contractile tension varies with the viscosity and with the thickness of the gel layer. In the fluid state, it is practically nil. In the gel state it is measurable. The "balance-pressure" of Kamiya (1940) is probably a measure of the contractile tension of the gel layer of the slime mold.

What are the limits of the contractility of the gel layer? The following quotations from Mast and Edwards seem to indicate that the gel layer can contract until all the endoplasm is squeezed out of an ameba through an artificial hole in the plasmolemma and plasmogel. Nothing is left but a small mass of plasmogel covered by wrinkled plasmolemma. In other words, the plasmogel can contract until it meets plasmogel. This is of especial interest. In the first place, if the contraction of the plasmogel is due to the elastic recoil after stretching, then we must imagine that stretching began at the instant plasmosol appeared, if there was ever such a time. This rather counts against the elastic recoil idea. We have other evidence of the great contractility of the gel layer, as for example on the tail buds of the lymphocyte and the cleavage furrow of dividing cells. Mast (1926, p. 404) states, "There is an abundance of evidence indicating that the plasmagel and the plasmalemma are elastic and they are usually somewhat stretched and consequently exert inward pressure; that is, that amebae are usually turgid. If pressure is brought to bear on the cover glass with an ameba under it, the plasmagel and the plasmalemma break and the plasmasol flows out, leaving nothing but a small mass of plasmagel covered with the

plasmalemma, which is much wrinkled. This usually occurs even if the pressure on the cover glass is relieved as soon as the plasmasol begins to flow out. Under these conditions, the continued flow must be due to inward pressure produced by contraction in the plasmagel or the plasmalemma. The fact that the plasmalemma is much wrinkled after the plasmasol has flowed out, clearly indicates that the pressure is due primarily to contraction in the plasmagel." Edwards (1933, p. 11) found "If N/1 NaOH or KOH is applied at any point on the surface of ameba there is an immediate rupture of the ectoplasm at that point through which the endoplasm flows until nearly all of it has passed into the surrounding medium. Nothing remains except a few crystals which adhere to the inner surface of the ectoplasmic sheath."

The next important consideration concerns the *local changes of viscosity*, gel layer into fluid or semifluid endoplasm, and endoplasm into gel layer. This can be followed with ease in the ameba and especially so in the slime mold under the oil immersion lens. These changes are continually going on in all active cells and ameboid organisms. In the ameba and the slime mold the numerous granules in the protoplasm act as indicators of such changes by the presence or absence of Brownian movement or by their flow in the streaming endoplasm. In both the ameba and the slime mold the granules are enclosed in minute vacuoles in which they show a limited Brownian movement even when the vacuoles are embedded in gelled protoplasm. In the slime mold one can watch viscosity changes in exceedingly minute areas with the oil immersion lens. When the protoplasmic matrix gels, the vacuoles come to rest, and when it solates, they show Brownian movement before they join the endoplasmic streaming. There is no doubt about the changes in viscosity, but the factors which bring them about are unknown. Probably the factors which are responsible for the production of the outer gel layer and inner less viscous endoplasm are internal.

Local changes of external pressure may evidently produce local changes of viscosity as indicated by the following quotation from Mast (1931, p. 328), which applies to an ameba in a capillary tube. "The following results were obtained: If the pressure against the advancing end of an ameba in the tube is increased, the direction of flow in the plasmasol immediately reverses, and the opposite end begins to extend, usually in several different regions, a protuberance with a hyaline cap forming in each region. These protuberances, however, soon unite, resulting in the transformation of the posterior

end into an anterior end with a typical hyaline cap. If the pressure against this new anterior end is now increased, the direction of flow again immediately reverses and a hyaline cap again forms at the opposite end. This can be repeated many times on the same individual, provided some little time is allowed for recovery between successive reversals in the direction of pressure."

Internal pressures may also play a role. As endoplasm is forced forward into the softened anterior end of the slime mold, the internal pressure there increases. It is possible that when the pressure reaches a certain point, gelation may occur and increase until the resulting increase in contractile tension increases the internal pressure to a point where solation results.

We come now to the *regulation and polarization* of the viscosity changes. It is quite evident that there must be some sort of a regulation of these changes, otherwise progressive locomotion could not occur except accidentally. The continued or periodic softening at the anterior end and the greater contractile tension at the posterior end are necessary for progression. Pseudopodia may be thrust out and withdrawn from various regions of an ameba or a cell without locomotion. Some sort of a polarization is needed. The thickness and the viscosity of the gel layer, which determines its contractile tension, are undoubtedly regulated, as are also the amount and viscosity of the endoplasm. There are probably both internal and external environmental factors involved.

Various authors have questioned the validity of the theory that the contractile tension of the gel layer plays an essential part in locomotion. The older ideas that surface tension plays a leading role can be dismissed without comment. More recently Marsland and Brown (1936) have questioned the contractile tension theory as will be seen by the following quotation: (p. 177) "Streaming of the plasmasol in a forming pseudopodium is immediately stopped by sudden compression to about 250 atmospheres." (p. 175) "On the hypothesis that the flow is caused by a contraction of the proximal portion of the plasmagel tube, forcing the plasmasol distally into the forming pseudopodium the cessation of movement might be attributed to a loss of tension throughout the entire plasmagel tube due to the liquefying action of the pressure. On this basis the flowing of the plasmasol would cease when, as a result of the increased fluidity of the plasmagel, the force exerted by the plasmagel tube becomes too small to overcome the resistance to flow. It is questionable, however, that a constriction in the plasmagel tube is a neces-

sary factor in the streaming of the plasmasol. If the ameba is to be considered as a contractile sac filled with fluid, one would expect that the movement of the fluid would always be accompanied by an inward displacement of the contractile wall. This, however, is not always the case. Specifically, in an ameba capped with an oil drop, a steady fountain streaming is maintained for hours despite the fact that no change occurs in the oval contour of the cell. In this instance it is evident that the constriction of the plasmagel wall is not essential for active streaming . . . An alternative suggestion as regards the cause of streaming would be that the volume changes inherent in the sol-gel transformations may generate the flow." Their objection to Mast's view is based on the observation that "a steady fountain streaming is maintained for hours despite the fact that no change occurs in the oval contour of the cell." I wonder if they observed what went on inside of the ameba as carefully as Mast (1926) did. He occasionally noted monopodal amebae that were unattached except at the tip of the posterior end, so that locomotion was prevented. (p. 400), "In such specimens the movements of the plasmasol and the plasmagel are precisely the same as they are in moving specimens, but in reference to points in space, the plasmagel actively moves backward instead of being at rest. This gives the appearance of typical fountain streaming." (p. 401), "This seems to indicate that in these specimens the plasmasol flowed through the elongated canal in the plasmagel, that when it reached the anterior end it spread out in all directions, deflected backward, came in contact with the anterior border of the plasmagel tube and gelled here, extending this tube which moved backward as rapidly as it was built up, sliding under the plasmalemma which everywhere remained stationary." Mast does not explain further, so I venture to extend the explanation a little. Continuous contraction of the posterior end of the gel layer pulls the plasmagel wall backward. This posterior end is also continually solating and thus keeping a balance between sol and gel. It would be rather difficult to explain this backward pull on the basis that the contractile tension of the gel layer was due to an elastic recoil from stretching. Such a sessile ameba might very well continue fountain streaming without much if any distortion of the posterior end such as Marsland and Brown record. Their suggestion that "the cause of the streaming would be that the volume changes inherent in the sol-gel transformations may generate the flow" seems to me unwarranted, because the same factors are involved in

fountain streaming as in locomotion and as Mast (1926, p. 407) points out "could in no way be involved in the forward extension of the pseudopod, resulting in locomotion." The cessation of streaming of the plasmasol by pressure is thus probably due to the decrease in the viscosity of the plasmagel.

LOCOMOTION OF AMEBA

The locomotion of *Ameba proteus* can be considered as the type representative of ameboid locomotion. The classical papers of Mast on the structure and locomotion of *Ameba proteus* contain the most important account of this. They contain a detailed study of the structure which is essential for any understanding of locomotion and of the various factors involved. Every visible detail, including those seen with the highest powers of the microscope, is important as are also all the changes which occur from moment to moment during a period long enough to cover a complete cycle. Even with the most complete record of the visible structure and all the visible changes it undergoes in locomotion or any other process, one comes immediately to the invisible structures and processes which are still more fundamental, but unfortunately they are still obscure.

Mast's account of the structure and locomotion of the *Ameba proteus* is too well known for me to consider it in any great detail. The moving ameba has a plasmogel layer surrounding a fluid plasmosol. The gel layer is thick over the sides of the tubelike body, somewhat less thick at the posterior end, and thin over the anterior pseudopod. The outer plasmolemma and the necessity of a substratum need not be considered. Contraction of the plasmogel at the posterior end drives the plasmasol forward and extends the pseudopod at the weak anterior end. As the posterior end of the gel layer contracts, it shortens and loses material because part of it keeps going into solution. This sol mixes with and is carried forward in the plasmosol. The posterior end is thus gradually shortened. At the anterior end some of the plasmosol goes to the lateral wall of the pseudopod and there gels as it comes in contact with the anterior end of the thick plasmogel tube wall. The tube wall is built up anteriorly as rapidly as it solates posteriorly. The following significant observation by Mast (1923) is readily explained by the above considerations, but not by any of the other explanations of ameboid locomotion. (p. 259) "If a given granule in the plasmosol is continuously observed it can be seen to move forward in the neighborhood of the central axis of the ameba until it reaches the

enlarged portion near the tip of a pseudopod and then to deflect outward where it sooner or later comes in contact with the edge of the opening in the sac of granular plasmagel where it is caught in the gelation of the fluid in which it is suspended and becomes stationary in reference to points outside, regardless as to whether it is to the right or the left or above or below the plasmasol. As more and more substance from the plasmasol is deposited at the anterior border of the granular plasmagel the ameba moves forward and the observed granule approaches the posterior end where it sooner or later comes to the inner surface of the plasmagel. Here the substance in which it embedded goes into solution carrying the granule into the plasmasol in which it is again transported to the anterior end where it again enters the plasmagel, etc." (See also Fig. 7, p. 409, Mast, 1926.)

Many questions remain unanswered, such as the regulatory mechanism, the factors involved in solution and gelation, and the origin of the contractility of the gel layer.

LOCOMOTION OF CELLS

The migrating mammalian lymphocyte exhibits typical ameboid locomotion. It has a thin gel layer, a central less viscous endoplasm, a persistent posterior end with a hyaline tail bud, and an anterior pseudopodal end. It has, relative to its size, a very large nucleus. The lymphocyte is one of the smallest cells of the body. The thin cortex is not always recognizable, and one infers from the behavior of the lymphocyte during locomotion that this layer must be a contracting gel. Each time a pseudopod appears, a constriction ring develops at its base where it joins the body of the cell. As the lymphocyte advances, the constriction ring remains stationary in relation to a point outside the cell exactly as does a particular granule embedded in the anterior part of the plasmogel of the ameba. As the lymphocyte moves forward, the body of the cell posterior to it gradually decreases in size. The large nucleus as it is forced through the constriction ring is constricted and distorted by the ring, and when it is finally pushed through the ring it regains its original spherical form. It is evidently elastic. When all but the little tail bud has passed through the ring, the latter contracts down and increases the length of the tail which undergoes shortening between each such addition. One cannot see very much of what goes on in the cell. The flowing forward of the few mitochondria can sometimes be seen. There is very little endoplasm and only a

few granules in it. I have not been able to see either the solation at the posterior end or the gelation that extends the wall of the body forward, yet from the manner in which it migrates, it seems as though exactly the same fundamental events must occur as in the ameba (Lewis, 1933, 1939).

The neutrophilic leucocytes are somewhat larger than the lymphocytes and have the same sort of ameboid locomotion. The anterior pseudopods are more changeable and the tail bud shorter. A constriction ring develops at the base of the advancing pseudopod which, like the one on the lymphocyte, does not move forward. The endoplasm contains numerous granules which stream forward into the advancing pseudopod. It is quite evident that contraction and solation of the gel layer posterior to the constriction ring continues until all but the tail bud is carried forward in the endoplasm and built up in front of the constriction ring. The granule-free gel layer is very thin. It has not been possible to see either the solation at the posterior end or the gelation anterior to the constriction ring. The presence of the constriction ring, however, is the key to the idea that they as well as other species of white blood cells have the ameboid type of locomotion.

Both the lymphocyte and the neutrophile move much more rapidly than a fibroblast and appear to have a less viscous endoplasm than the latter. Fibroblasts and sarcoma cells move very slowly. One cannot detect in the course of a few minutes any forward movement. Such cells, however, occasionally develop a constriction ring which indents and distorts the nucleus. These rings, like fixed granules of the ameba and the constriction rings of the lymphocyte do not move forward, yet the nucleus is slowly pushed through them in the course of four or five hours, presumably by contraction of the posterior part of the cell which pushes the nucleus and rather viscous endoplasm very slowly forward. It seems quite probable that fibroblasts, and sarcoma cells which are derived from them, have a very slow ameboid locomotion because the endoplasm is almost as viscous as the gel layer.

Ruffle pseudopodia and undulating membrane common on white blood cells, macrophages, connective tissue cells, and sarcoma cells consist of exceedingly thin sheets of hyaline protoplasm. They often extend into the fluid medium of cultures and are always slowly bending back and forth like the ruffles on a dress in a slight breeze. They probably have an outer thin gel layer and a central somewhat less viscous endoplasm. Slight local changes in the viscosity of the

gel layers would change the contractile tension and produce the wavy motion. The motion of cilia, fibrillae, and undulatory membranes in general can be fitted into the idea that slight changes in the viscosity of gel layers or gels alter the contractile tension which they automatically exert because they are in the gel state.

LOCOMOTION OF SLIME MOLD (*Physarum Polycephalum*)

In studying the slime mold one should distinguish, as Howard (1931) suggests, between growth, spreading, and locomotion. Growth is actual increase in the mass of the protoplasm and is presumably accompanied by nuclear division. Spreading may or may not be accompanied by growth and locomotion. Locomotion is always accompanied by spreading at the anterior end.

The minute pieces with which I propose to deal are examples of locomotion and spreading. Most of the pieces for my preparations were made from the tips of the plasmodia that had spread out over the surface of the water in the Petri dish (100×15 mm.) cultures during the preceding night or on the same day from the elevated filter paper at the center on which there was a generous supply of oatmeal. There were considerable differences in the age of the cultures, in the growth, and in the spreading. There were likewise great differences in the behavior of the small pieces in the different preparations. The pieces (6-12) in each preparation were always from the same tip and as a rule behaved in much the same manner. I have not as yet attempted to investigate carefully the relation of the condition of the culture and the type of preparation obtained from it. There are such very great differences in the behavior of the pieces that an investigation of their relationship to the condition of the culture and to the part of the plasmodium from which they are taken must yield some very interesting results. The preparations were made by taking a few millimeters from the spreading tip of the plasmodium with a pair of forceps, transferring to a small Petri dish with water and tearing up into smaller pieces 3 to 4 millimeters long. One of these was transferred to a thin spread-out drop of water on a clean cover glass and then teased or cut up with the needles into pieces a millimeter or less in diameter. The cover glasses were sealed in the usual hanging drop manner over a hollow slide or ring.

Small pieces show at first no or almost no internal movements of endoplasm, due either to complete or almost complete gelation as a result of the mechanical stimulation of tearing with the needles.

The endoplasm evidently gels as the pieces are divided because it does not flow out at the cut end. In the course of a few minutes or so, small pseudopodia begin to extend out from the periphery and show typical elongation and retraction with each outward and inward flow of tiny streams of endoplasm. The pseudopodia seem to be confined to the peripheral border of the piece that is in contact with or close to the cover glass. The entire periphery of good, active pieces, which are the ones we are considering here, may show such pseudopodia. Contractions and relaxations of the central piece were sometimes noted. As the pseudopodia extend out radially farther and farther, the tips become multiple, frequently come in contact and fuse with neighboring ones to form a plasmodial network and sheet back of the advancing tips or pseudopodia. In the course of an hour or so, when most of the little chunk at the center has gone out into the thin plasmodial net and sheet, some of the advancing ends become retracting ends and the piece begins to migrate. Most of the active plasmolets ultimately arrive at the periphery of the thin drop. Whether this is due to some chemotactic response (Coman, 1940), or to chance trapping is unknown. During the course of a day the pieces undergo many changes of form, and the small ones sometimes fuse to form larger ones and sometimes the larger ones divide.

The smallest simple active pieces that have begun to migrate show in the course of an hour or two an organization that is much like that of an ameba in its fundamental aspects. They consist of a fluid endoplasm, the plasmosol and a tubular body with a thick gel wall, the plasmogel, which continues into a simple thick-walled posterior end and a broad fan-shaped transition zone, which terminates in a lobulated crescentic anterior end with numerous pseudopodia. The locomotion of one of these small pieces of plasmodium is in general very much like that of the ameba, except for the rhythmic reversals of the endoplasmic flow, the complications of the transition zone, and many little minor solations and gelations which frequently give rise to many very small temporary streams of endoplasm which connect with channels and tubes. Contraction and partial solation of the posterior part of the gel layer forces the endoplasm forward through the tube and channels to the anterior end, where it forces out pseudopodia at weak places and builds forward the plasmodium at their bases. After about thirty seconds, gelation sets in at the anterior end; the resulting contractile tension there, together with partial solation reverses the endoplasmic flow and expands the posterior weakened end. After about thirty seconds, gelation at the

posterior end increases the contractile tension and reverses the flow and repeats the cycle. There is a net gain at the anterior end and a net loss at the posterior end with each cycle.

Most of the active pieces obtained by tearing are somewhat larger and more complex and have one or more branching and anastomosing thick-walled tubes, one or two or more posterior retracting ends, one or more thick, lobulated, anterior, advancing ends which project from a broad flat plasmodial sheet with thick and thin areas that grade into the tubular region. The thicker areas of the sheet are traversed by branching and anastomosing channels which merge into the tubes posteriorly and into minute, more or less temporary, terminal channels leading to each lobule and pseudopod anteriorly. The same type of organization found in the small plasmolets prevails also in the larger ones and undoubtedly also in the relatively enormous masses of the stock cultures under approximately the same conditions where growth and locomotion are fairly rapid. When examining an especially selected small plasmolet a millimeter or so long in a preparation 2-3 hours old, it is convenient to consider separately the organization or structure and the behavior of the different regions, namely, the posterior end, the tube, the fan-shaped transition zone, and the anterior end.

Posterior ends differ considerably; they may be blunt or drawn out into long tenuous tapering threads. The usual blunt ones have a gel wall continuous with the tubular part, but it is not, as a rule, quite as thick as the latter. Sometimes there is an outer hyaline zone and sometimes not, depending upon the condition of the plasmodium. In the course of a few minutes the hyaline zone may completely disappear and then reappear again. Sharp hyaline spicules such as Camp pictures at the posterior end may come and go in the course of a few minutes. The limits of what one might designate as the posterior end are rather indefinite as its gel layer merges into the gel wall of the tube and they function more or less as a unit. One might limit it to the region where during contraction and forward flow of the endoplasm some of the gel layer solates and mixes with the endoplasm. The two most interesting points about the posterior end are its contraction and the partial solation of its gel layer during the contraction. One can see this local contraction of the posterior end and often in addition to this a more general shortening of the posterior part of the tube which pulls the posterior end forward rather rapidly at the time of the forward flow of the endoplasm. Solation at the posterior end occurs during the contractile phase only

and begins after the contraction and forward flow of the endoplasm has started.

Solution at the posterior end during the contractile phase is accompanied by the flow of great numbers of granular vacuoles into the endoplasm from the inner wall of the gel layer where they previously had been at rest. Sometimes one can also see many tiny streamlets of granular vacuoles flowing, often in single file, through most of the thickness of the gel layer into the endoplasm. It is evident that solution of the hyaline gel matrix in which the granular vacuoles are embedded occurs during contraction. This is an interesting relationship and is in marked contrast to what occurs at the posterior end when the endoplasmic streaming is reversed. The backward flow of the endoplasm expands and lengthens the posterior end, but it does not usually lengthen to the original length that it had at the beginning of the cycle if the plasmolets are moving forward. There is a net loss at the posterior end during each cycle. As the posterior end lengthens and expands, some of the endoplasm comes to rest on the inner surface of the wall and seems to gel in situ. The expansion at the posterior end is presumably due to the internal pressure of the turgid system on the somewhat weakened gel layer resulting from excessive solution during contraction. Expansion and gelation appear to go on at the posterior end until the gel layer becomes thick or viscous enough to automatically exert a sufficiently increased tension to contract and overcome the internal pressure of the endoplasm and reverse the flow. This is undoubtedly correlated with tension changes at the anterior end and in the whole system of tubes and channels. It is quite possible that the weakened condition at the posterior end is in part due to a general decrease in the viscosity of the gel layer throughout most or all of its thickness.

The *tubes* consist of a thick gel wall through which the endoplasm flows back and forth. They are relatively permanent, but still only temporary, structures. The length of time they persist depends upon how rapidly the plasmolet is moving and changing form. By the time a plasmolet has moved forward a distance equal to its length, it has been completely torn down and rebuilt anew from end to end. The posterior end tubes are the oldest part of the plasmodium. The condition of the slime mold at the time the preparations are made seems to make considerable difference in the general appearance of the gel layer of the tube. In some preparations it is very much lobulated and very uneven; in others it is rather smooth.

The diameters of tubes differ as do also the thickness of the gel walls and the diameter of the endoplasm. There are probably some definite correlations between the size of a tube and the size and rate of increase in size of the anterior region of the plasmolet to which the tube delivers endoplasm and the amount of endoplasm which streams through it. Tubes undergo changes in size. The thickness of the gel walls differs both absolutely and relatively as regards the diameters of the tubes and the diameters of the endoplasm. There is probably a definite correlation between the thickness of the gel wall, the viscosity of the gel, the size of the tube, and the internal pressure of the endoplasm. There can be no doubt about the gel state of the tube wall. Camp found it tough when stuck with a needle. In the large culture dishes numerous ends often stick up into the air.

The tubes usually contract, that is, decrease in diameter and length, during each forward flow of the endoplasm, and expand during each backward flow, but not to their previous posterior extension. The tubes are built up anteriorly by transformation of channels in the transition zone.

Sometimes the endoplasm flows back and forth for a short time without much of any change in the thickness of the gel wall, but within a few minutes the same tube may show solation along its inner surface with each forward flow and gelation with each backward flow. This is not always confined to the inner surface, for minute streams in and out of much of the thickness of the wall can be detected here and there. Sometimes projections on the inner surface of the tube deflect the stream of endoplasm for varying lengths of time. Such projection seems to be due to quite local and temporary increases in viscosity and contractions. The general behavior of the tube is thus similar to the posterior end and acts with it as a unit.

Tubes frequently have an outer hyaline zone, but this often comes and goes as at the posterior end. The hyaline border is usually uneven and more marked on the plasmolets of some preparations than others. Sometimes a tube with a rather thick hyaline zone will in the course of a few minutes lose it entirely, or part of it, and the granular protoplasm will extend to the very periphery. My explanation of the origin of the hyaline border is the same as that of the hyaline cap of Mast. The granular gel layer at times permits clear granule-free endoplasm to be squeezed through its pores to the surface under the interface membrane. Here it gels or partly gels. With subsequent changes in the viscosity of the granular and

hyaline zones they become mixed and the granules reach the periphery.

Tubes not only contract and relax, but they shorten and lengthen, bend and straighten, and undergo various contortions which indicate that there is some sort of a contractile mechanism. This is undoubtedly the gel layer. Tubes usually show a considerable amount of shortening during the forward flow and the posterior end is carried forward rather rapidly. During the backward flow they lengthen but do not regain their former length. Sometimes tubes contract locally and completely stop the streaming of the endoplasm through the constricted region for a short time. The endoplasm usually then streams in both directions from the constriction. Such tubes usually relax and the flow of the endoplasm is resumed through the tube. Sometimes there is a permanent obliteration of the flow and the tube later disappears. Other tubes undergo a more or less permanent increase in size. Such changes and alterations are correlated with shifting increases and decreases of the advancing ends. I have noted, occasionally, small pieces a few millimeters in size, on the bottom of a Petri dish partly filled with water, send out tube-like elongations at various angles which slowly squirm like a bunch of worms.

We come now to the *transition zone* which spreads out fanlike from the anterior end of the tube to the broad crescentic lobulated anterior end. It is a difficult region to understand and to present. There is nothing in the ameba which corresponds to it. One should bear in mind that the slime mold moves forward by a tearing down at the posterior end and building up at the anterior end with the protoplasm which is transported in the endoplasm from the posterior end and other retracting lateral ends and areas. It is obvious that the plasmolet cannot continue to advance or build up in all regions of the crescentic periphery if it is to move forward. One sector builds up more rapidly than adjoining ones. The latter sooner or later retract by contraction and solation and transport of the protoplasm to the more rapidly spreading or advancing sector. Corresponding with this, there is a progressive enlargement and building forward of the channels leading to the advancing sector and a diminution and disappearance of those that supplied the adjoining and retracting ones. During this transformation the broad fan-shaped plasmodial sheet undergoes transformation. The thick anterior part becomes thin and a new thick part is built up in front in the active sector. The middle part of the sheet develops thin areas between the

channels. These thin areas, as Camp noted, may become fenestrated; the protoplasm partly retracts and partly solates and becomes incorporated into the tubes, contributing endoplasm and material to the gel wall. If one followed the fate of tiny terminal channels leading to the pseudopod which is destined to form the center of the advancing sector, it would be noted that this channel without moving forward would gradually enlarge until it became the main tube with the thick gel wall.

The channels in the anterior part of the transition zone through which the endoplasm flows are surrounded by the broad gel sheet and do not have definite walls. In the posterior part where the channels are larger there is a gradual transition into tubes that have more and more definite walls like those on the tubes into which they are continued. Probably all the changes which the transition zone undergoes can be correlated with the building up of the advancing sector and "demand" for endoplasm. Camp has described many of the changes which took place in the broad continuous sheet which I have designated as the transition zone without indicating their relation to the building up of the advancing sector. Camp states (p. 327) that the "Protoplasmic movement or locomotion in a plasmodium is so similar to the same phenomenon in the rhizopods that when the correct explanation is found for the one, it will probably hold true in most of its aspects for the other." Although he quotes Mast at some length, he does not apply the principles of ameboid locomotion to the plasmodium. If one applies these principles, all the visible changes fall into line.

The broad crescentic *anterior end* is thick, and it is often difficult to see exactly what happens from moment to moment. The anterior ends are usually more or less lobulated. In some preparations all the migrating plasmolets show marked lobulation, while in others it is almost absent. During the forward flow of the endoplasm, the tip of each lobule expands and extends forward into one or more pseudopodia or protuberances described by Camp. In some preparations the forward flow of the granular endoplasm usually completely fills the rather rapidly expanding pseudopod. In other preparations, the expanding tips often become filled with granule-free hyaloplasm (Figs. 1-4). Camp suggests that the granules cannot enter because the hyaline pseudopod is too thin. This may apply to some cases, but many of those that I have observed are thick and rounded and have ample thickness for the granules. At the base of such a hyaline cap there is a slightly rounded, bulging layer of granular

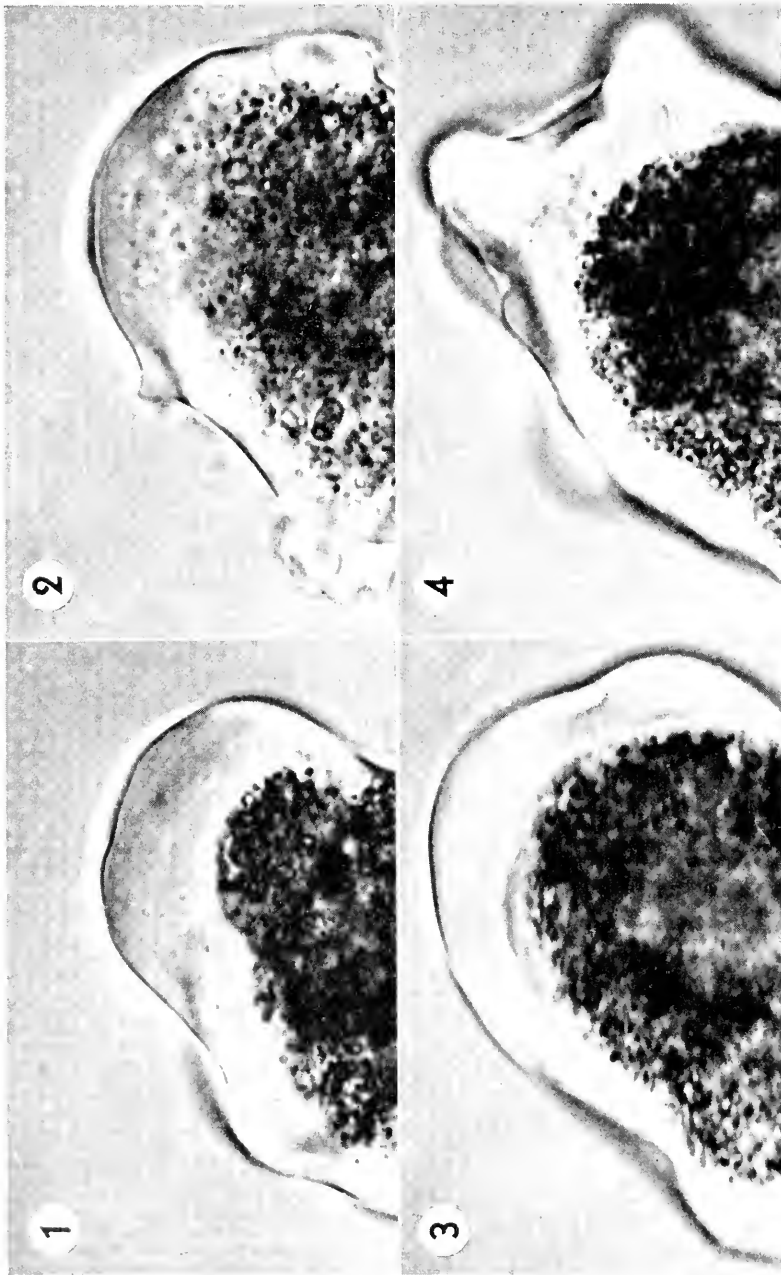

FIGS. 1-4. Advancing end of a slime mold, from a series taken at 10-second intervals without moving the camera. The base line has remained constant. The advance and retraction can thus be measured. $\times 1,200$ dia.

FIG. 1. Hyaline cap at the tip of an advancing pseudopod showing the even bulging contour of the granular gel layer.

FIG. 2. Same tip, 40 seconds later. The thin gel layer has disintegrated, and granules are filling the cap.

FIG. 3. Same tip, 20 seconds later. Gelation of the periphery of the granular protoplasm and the formation of a new hyaline cap.

FIG. 4. Same tip, 30 seconds later. Retraction of the pseudopod and irregular hyaline cap.

protoplasm which is evidently in the gel state. This holds back the granular endoplasm which piles up behind it, but seems to permit, as Mast has suggested for the ameba, the hyaloplasm to filter through its pores to form the hyaline cap. This rather thin, granular, plasmogel membrane often has a smooth outline bordering the base of the hyaline cap, and its granular vacuoles are at rest. This membrane may persist, or a small local break or two may occur and small streams of granules suddenly pour through them into the cap. Then the entire membrane may give way and the cap rapidly fill with granules and all traces of the gel layer disappear. The anterior end does not possess a thick, tough gel layer such as one can see and manipulate at the posterior end and tube region. There is much more protoplasm at the anterior end and in the anterior part of the broad transition zone than in the tube and posterior end, but it seems to be less viscous. With each forward flow of the endoplasm produced by the contraction of the gel layer at the posterior end and on the tube, this mushy protoplasm is pushed forward within the bulging boundaries of a rather thin gel layer of the lobes. At the weakest areas, the pseudopods and hyaline caps form and bulge out still more. Forward flow is probably much impeded and slowed by the friction in the relatively large number of small and minute terminal channels. The forward flow and expansion cease with the increase in the viscosity and partial gelation of the lobes and of the pseudopods. One can detect these changes by the absence of the flow and the absence of Brownian movement of the granular vacuoles. This is probably not a very viscous gel, but there are many such ends. It seems probable that height of gelation is synchronized with a weakening of contractile tension at the posterior end so that the contractile tension which now develops at the anterior ends as a result of the increased viscosity and gelation reverses the endoplasmic flow.

During the anterior contraction period each pseudopod contracts and shortens. They do not always contract simultaneously, and an occasional new one may form. The amount of contraction usually falls short of the previous gain so that there results a net forward gain with each cycle. The contraction usually involves more than the pseudopodal tip and there may be a considerable amount of retraction of the whole lobe. During the contraction there is a backward flow of the endoplasm. Small, more-or-less temporary streams from neighboring tips join to form larger and larger channels which unite and join to form the tubes. A large part of the

slightly gelled protoplasm of the pseudopods solates and joins the endoplasm. The endoplasm is also enhanced by solation along the borders of these small streams. The solation and backward flow continues until the tips are weakened and the contractile tension becomes less than that which develops at the posterior end. The flow is then reversed, and the cycle is repeated.

There are a number of important differences between the anterior end and the posterior end. The small plasmolets with a single posterior end and one main tube about 100 microns in diameter may have a dozen lobes at the anterior end with one to four pseudopodia on each one. The main tube branches and rebranches in the broad zone into about forty more or less temporary little terminal channels which supply approximately a corresponding number of pseudopodia. Some lobes enlarge, subdivide, and spread more than others. The channels leading into such lobes increase in size as do also the number of branches and the number of terminal channels. Some lobes decrease in size and become retracting ends, and a reverse series of events occurs until finally through contraction and solation all traces of the lobe are lost. The whole response of the branching system of channels and terminals to enlarging areas reminds one of the growth of capillaries and the formation of veins and arteries in growing regions of the vertebrate embryo. A fantastic comparison can be made of the functional response of the tubes and channels of the slime mold with the developing vascular system of man.

MICROSCOPIC STRUCTURE OF SLIME MOLD

The visible microscopic structure of the slime mold seems to be somewhat similar to that of the ameba as described by Mast (1926). The thin areas of the transition zone can be examined with the oil immersion lens, and Camp (1937) took advantage of them for his observations on the minute structure of the protoplasm. His description which I now quote can be readily confirmed (p. 316): "*The protoplasm*. Careful microscopic examination of very thin areas of a plasmodial sheet reveals the presence of an optically homogeneous substance which has an exceedingly faint bluish-gray color. This is the substance which is generally recognized and referred to as hyaloplasm. Scattered throughout the hyaloplasm there are numerous granules, vacuoles, and particles of ingested material. The granular bodies exhibit widely varying degrees of optical differentiation, and they vary in size from approximately 0.2 microns to slightly more than 1 micron. In general they are more or less

spherical, but some, especially the larger ones, may be irregular in shape. The smallest granules are rather highly refractive; they appear to be similar to those which Mast (1925 and 1926) observed in *Amoeba* and designated as 'alpha' granules, and they are similar to the microsomes described by Chambers (1924) and which he believes to be always present in protoplasm. Many of the granules are contained in very small vesicles which bear close resemblance to vacuoles."

"The vesicles do not possess well-defined boundaries, and in addition to containing one or more granules they seem to be filled with a substance which is more completely hyaline and less viscous than the surrounding hyaloplasm. That the material of these vesicles is in a liquid state is indicated by the fact that these granules which it surrounds are always in marked Brownian movement and can very clearly be seen to move freely from place to place in the vesicles." Granules not in vacuoles may at times exhibit very slight Brownian movement.

To this account, I might add a few observations. Minute areas of solation frequently occur in the thin areas, and one can see the little vacuoles with their contained granules move out into the flow of newly formed endoplasm. When endoplasm gels again in such areas, the vacuoles can be noted as they come to rest. This indicates that they either have or acquire a definite wall when the hyaloplasm surrounding them solates. It thus seems quite probable that even in the streaming endoplasm of the large channels the vacuoles persist. One can sometimes detect them when the endoplasm comes to rest. Some of the granules noted by Camp were not in vacuoles. These I have also noted in great numbers. They are considerably smaller than the vacuoles, are grayish in color, and are best seen in areas that are too thin to accommodate the vacuoles. They stain with Janus green and are mitochondria. They occur all through the gel layer and endoplasm. The contractile vacuoles also noted by Camp and others are often quite numerous in the neighborhood of the thin areas and throughout the gel layer. They, like the granule-containing vacuoles, are freed and carried into the endoplasmic stream when the surrounding hyaloplasm solates. They also either have or acquire a definite wall.

Camp does not mention the nuclei which are present in great numbers. They are small, round, and have a single, rather large, gray nucleolus. They are very difficult to see, because the nucleoplasm is optically similar to the gelled hyaloplasm, but once one

has learned to recognize them they can be detected in the neighborhood of every thin area as grayish areas surrounded by the small granule-containing vacuoles, with a darker gray nucleolar center. They are much larger than the granule-containing vacuoles. A flake of iodine placed under the cover glass soon reveals great numbers of nuclei and also a diffuse port-wine color in the protoplasm indicating the presence of glycogen.

VISCOSITY OF SLIME MOLD

The following quotation from Camp expresses in general terms rather obvious conclusions that one would reach from observations and testings with a needle: (p. 372), "All of those considerations would seem to lead to the conclusion that the viscosity of the protoplasm of a plasmodium varies from place to place in the plasmodium, that it changes with changing external and internal conditions, and that alterations in the physical state, i. e., changes from sol to gel and gel to sol, take place more or less constantly throughout all parts of a plasmodium. Normally, therefore, the protoplasm of plasmodia does not have an absolute and unchanging viscosity, and variations in its viscosity seem to be due to alterations in the physical state of the hyaloplasm."

Perhaps the presence of great numbers of small vacuoles, mitochondria, and nuclei and the relatively small amount of hyaloplasm may have something to do with the apparent ease with which the protoplasm or hyaloplasm changes from sol to gel and gel to sol.

CELL DIVISION—MITOSIS

Cell division consists of a series of interdependent reactions which lead to a series of overlapping events, each of which takes a considerable period of time. Most, if not all, of the visible reactions are due to viscosity changes. The reactions lead to two essential events, the formation of the daughter nuclei and the cleavage of the cell into two parts.

Mitotic division of the nucleus is not always accompanied by cell cleavage so that perhaps none of the events which result in cell cleavage are necessary for mitotic division of the nucleus. The events, however, which lead to cell cleavage or at least some of them are probably dependent upon events which result in the mitotic division of the nucleus.

A brief outline of the events as exhibited by an ordinary living fibroblast in tissue culture is as follows:

The first-known event is the migration of part of the centrosome material to the opposite pole. This has not been seen or reported for living fibroblasts, but undoubtedly occurs some time before prophase.

Events leading to the formation of the daughter nuclei.

The only visible structures in a resting nucleus are one to several nucleoli, a homogeneous nucleoplasm, and a thin nuclear membrane. In early prophase fine granules appear in the nucleoplasm. They seem to become larger and larger and are recognizable as chromosomes toward mid-prophase. They ultimately almost fill the nucleus except for a small amount of nuclear sap between them. During the change from late prophase to metaphase the chromosomes become more distinct and probably smaller and occupy less space in what has now become the spindle than they did in the prophase nucleus. The condition of the chromosomes in the resting nucleus is obscure because they are invisible. It may be that they are swollen and of low viscosity, and occupy the entire nucleus. Gelation and then contraction of the chromosomes with a loss of fluid might make them visible and also account for their small size as compared with the relatively large amount of spindle material in metaphase stage.

The chromosomes split and move to the poles to form the two small compact masses and leave behind a large amount of exnuclear sap which extends across the midline from one mass to the other. These nuclear masses soon begin to increase in size as clear areas appear and increase in size and number. As the nucleus enlarges, the visible chromosome material gradually becomes more or less dispersed as granules. Most of them disappear, and the few that remain unite to form one to several nucleoli. It may be that there is a reversal of the prophase process in that the chromosomes take up fluid, swell and solate, and become invisible except for the nucleolar part.

The nuclear membrane seems to disappear in late prophase just before the chromosomes begin to move and does not become visible until after the daughter nuclei begin to increase in size. It is very thin and scarcely recognizable except as the sharp border of the nucleus. It is probably in the gel state. Its fate is unknown. Does it solate and disappear, or does it contribute to the spindle?

The chromosomes suddenly begin to move in late prophase. The movements are scarcely perceptible to the eye, but in motion pictures where events are speeded up they become quite pronounced. They

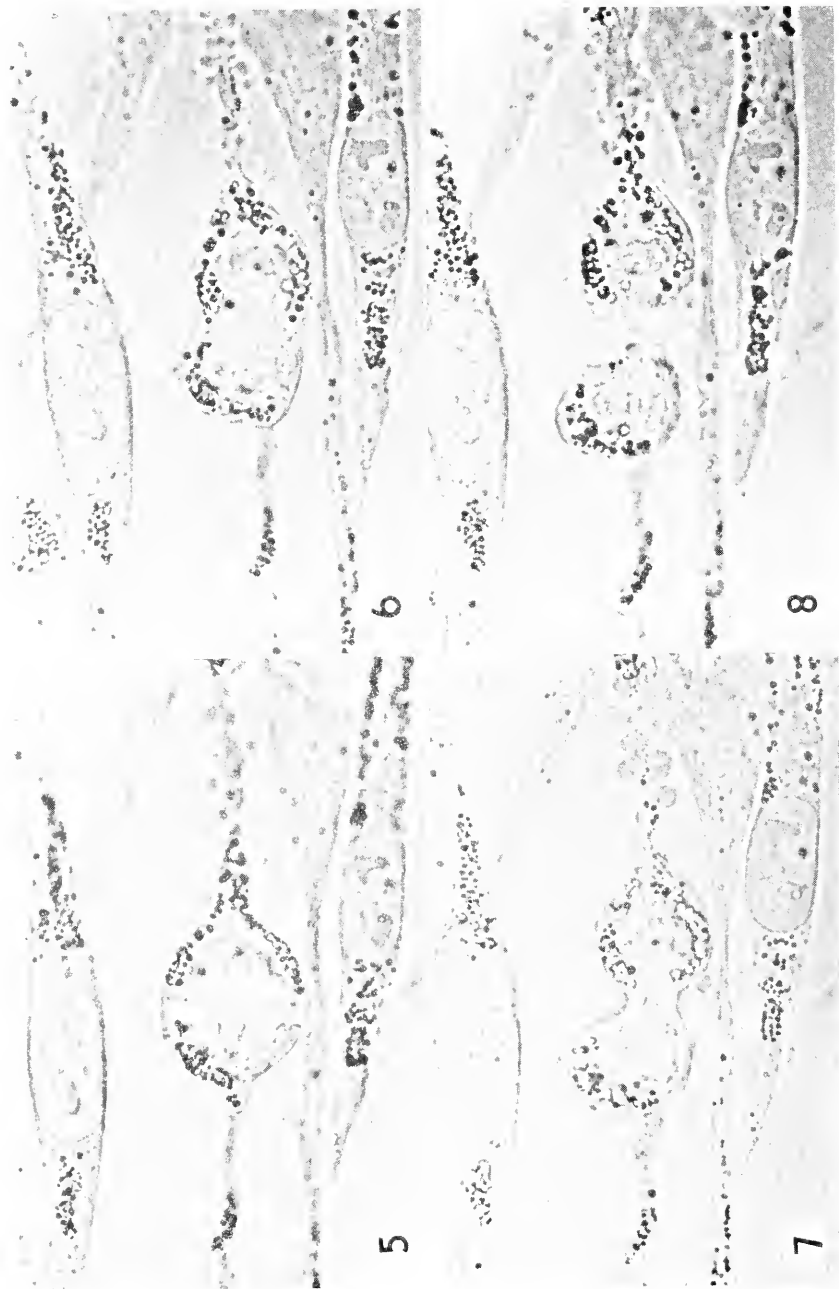

Figs. 5-8. Cleavage of a fibroblast from a 1-day mouse in a 2-day tissue culture. $\times 1,100$ dia.

Fig. 5. Late anaphase, incomplete retraction of apical processes. Between the two groups of chromosomes is the homogeneous exnuclear sap, the endoplasm has numerous dark fat globules.

Fig. 6. Five minutes later, Beginning telophase. Compact daughter nuclei widely separated by the elongated exnuclear sap which has been compressed. Fat globules are bent inward by the broad furrow.

Fig. 7. Two and one-fourth minutes later. Mid-telophase. Note blebs on one apical process. Compare with the hyaline cap, figures 1-4

Fig. 8. End of telophase.

are not Brownian movements. Since the movements continue until after the chromosomes become arranged in the metaphase plate as oscillations, they are probably produced by the same mechanism that is responsible for the oscillation. Perhaps invisible fibers, or spindle threads, form and gel sufficiently during late prophase to exert tension on the chromosomes to which they are attached. Variations in the viscosity and contractile tension of these gel-like threads which extend one from each chromosome to each pole would move the chromosomes into the median plate, and there produce the oscillations which move them individually in short paths in and out of the median plate toward the poles. There are no visible bands or fibers, but the fact that the chromosomes move individually a little in and out of the metaphase plate would seem to indicate that some sort of gel material exists and is also responsible for pulling the chromosomes to the poles.

The nucleoli split up into chromosome-like material almost immediately after the chromosomes begin to move. The splitting is probably in some way connected with the movements of the chromosomes to which the compound nucleoli are presumably connected.

Events leading to cell cleavage. (Figs. 5-11.)

At the beginning of prophase the cell processes and pseudopodia begin to retract, and the cell tends to assume a spherical form. The withdrawal of the processes is often incomplete. Withdrawal of pseudopodia is a common phenomenon and is probably due to an increase in the viscosity of the gel layer, which results in an increase of its contractile tension and a shortening or complete withdrawal of the pseudopod. It is similar to the changes which go on at the posterior end of the ameba or slime mold where contraction and solation go hand-in-hand.

The tendency of the cell to assume a spherical form may be due to an increase in the viscosity or thickness of the superficial gel layer until it becomes fairly uniform over the body of the cell and exerts a uniform contractile tension in all directions. There is considerable evidence, as will be noted later, that the gel layer of eggs increases in viscosity and thickness and becomes more rigid and stable before and during cleavage.

The metaphase cell is approximately bilateral, with the chromosomes in the equatorial plane. The spindle and poles are surrounded by a considerable zone of endoplasm with mitochondria, fat globules, and granules. The mitochondria are only approximately bilaterally distributed. The fat globules vary in number. They may

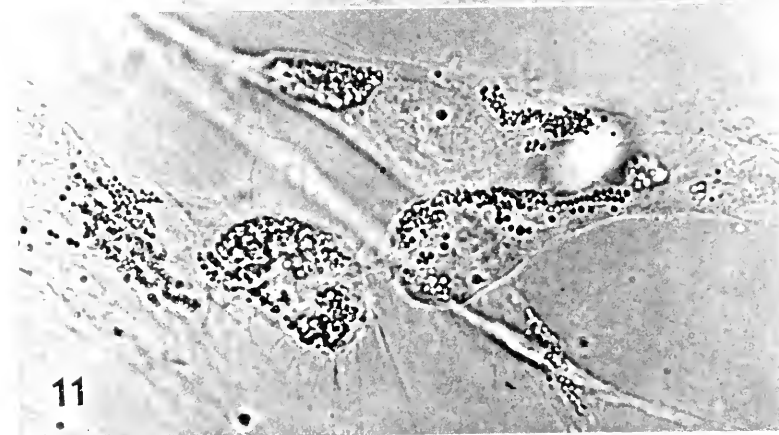
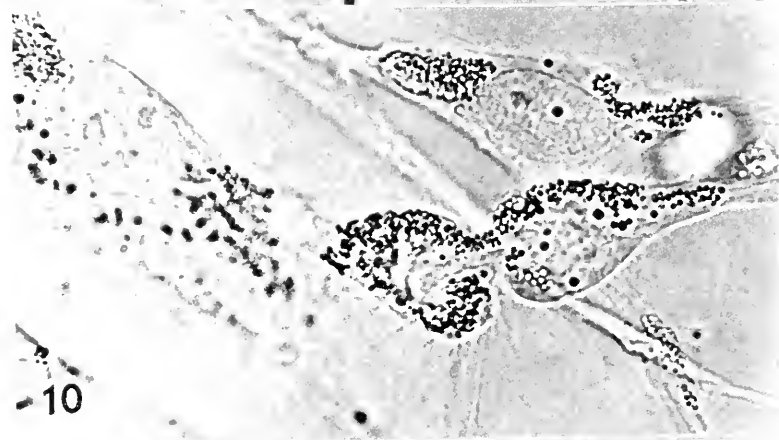

all be at or near one pole, or irregularly distributed across the equatorial plane. The endoplasm is rather dense in consistency, for there is no Brownian movement or streaming of its contained granules. The superficial gel layer is relatively thin and hyaline in appearance.

As the chromosomes move to the poles in anaphase, they converge to form compact daughter groups and leave behind a homogeneous granule-free interchromosomal material which is, or becomes, as will be seen later, less viscous than the endoplasm. It evidently consists of nuclear or spindle sap left behind as the chromosomes move to the poles. It is sharply distinct from the surrounding endoplasm. As the cell flattens in the equatorial region during anaphase, this interchromosomal material is squeezed from a blunt spindle shape to a cylindrical shape by the contractile tension of the gel layer. It probably plays an entirely passive role in this. It does not mix with the endoplasm at this stage.

The flattening of the cell is probably due to the contraction of a broad equatorial belt of the gel layer which has become more viscous or thicker than the rest of the gel layer. A decrease in the viscosity of the gel layer at the poles might also account for the elongation. It is possible that both factors are at play. There is scarcely any displacement of the endoplasmic granules and no apparent diminution of its thickness in the equatorial region during the flattening. This indicates that the endoplasm is rather viscous.

About the time, or shortly after, the chromosomes reach the poles and after polar elongation of the cell has occurred, the constriction groove, or furrow, appears in the equatorial plane. There are some indications that the gel layer is somewhat thickened in the region of the furrow. As the furrow deepens, it bends the endoplasm inward and the deep surface of the latter projects into the soft interchromosomal material. The endoplasm often has a row of fat globules extending across the mid-plane; they are bent inward and finally separated into two groups, one for each daughter cell when the endoplasm is later divided. With the deepening of the furrow, the endoplasm encroaches more and more on the interchromosomal material and finally divides it into two parts.

FIGS. 9-11. Cleavage of an adult rat fibroblast from a 2-day culture. $\times 1,100$ dia.

FIG. 9. End of anaphase, cell elongated, homogeneous exnuclear sap elongated, endoplasm with many small fat globules.

FIG. 10. Four minutes later. Mid-telophase, endoplasm with fat globules bent inward, exnuclear sap about divided.

FIG. 11. Three minutes later. End of telophase. Connecting stalk.

Endoplasm then meets endoplasm in a broad equatorial area. With the continued deepening of the furrow, by the contraction of the gel layer at the bottom of the groove, the endoplasm is divided and each half is incorporated into the endoplasmic layer of the daughter cells. At the bottom of the groove, gel layer then meets gel layer to form a stalk or band which connects the two daughter cells. This band usually persists until the cells migrate away from one another and stretch it to a thinner and thinner strand which finally breaks. Endoplasm and interchromosomal material mix after the former is divided and included in the daughter cells.

The observable steps in cleavage indicate that the interchromosomal material is less viscous than the endoplasm and the latter less viscous than the gel layer or gel band which contracts. The constriction band is presumably either a thickened or more viscous band of the gel layer, which develops around the equator after the cell has become bilateral. The cell becomes bilateral, or approximately so, when the chromosomes become arranged in the median plane. It has already been noted that cells flatten in the equatorial region as the chromosomes begin to move toward the poles and that the constriction furrow begins after they have reached the pole. The factors which produce the constriction band are unknown, but it seems probable that the new bilateral set-up may have something to do with it. Some metabolic products of chromosomes, centrosomes, and interchromosomal material may be involved.

During cleavage of the fibroblast there are no indications of any cytoplasmic currents or flow. As the endoplasm is bent inward by the contraction of the gel band, fat globules in the neighborhood of and at the bottom of the furrow are bent in; those at a distance are scarcely disturbed at all.

My theory of cell cleavage is based on the idea that gels automatically exert contractile tension and that the contractile tension of the gel layer is increased in the median equatorial plane by an increase of its thickness or of its viscosity, or of both in this region. This increase automatically leads to the contraction which pinches the cell in two. The existence of a superficial gel layer seems to be a fact. The automatic contractility, which it exerts because it is in the gel state, has already been considered. That the contractile tension varies with the thickness and with the viscosity seems like a probable assumption. Is there any direct evidence for the development of an equatorial band? The gel layer of fibroblasts, on which most of my observations are based, is rather thin, but one can some-

times see a slight thickening in the equatorial plane. When it contracts and meets in the center to form the stalk which connects for a time the two daughter cells, it exhibits marked thickness. Since the theory is relatively new, no particular attention has been given to this region with the idea that there might be such a thickening of the gel layer which then automatically contracts and pinches the cell in two.

Schechtman's (1937) observations on the cleavage of the eggs of *Triturus torosus*, according to my interpretation of them, not his, lend support to the idea that cleavage is due to the contraction of a thickened equatorial band of the gel layer. His observations and interpretations are here quoted verbatim. They are followed by my interpretation and comments (p. 222): "Cleavage is indicated by a contraction of the egg cortex at the site of the future furrow. This is a contraction in the sense that the cortex becomes thickened and bulges toward the interior. At the same time the surface of the egg is displaced toward the site of the thickening." This is exactly what one would expect when the thickened equatorial band of the gel layer begins to contract. "The mid-portion of the contracted cortex begins to expand within one to two minutes after the above contraction (at temperatures ranging from 22° to 26° C.). The pigment of this expanding portion is rearranged in irregular streaky lines, plainly indicating that the cytoplasm is being stretched. The surface of the stretched material sinks below the general egg surface much as does the surface of a fluid material stretched between relatively firm supports." The continued contraction of the band at the bottom of the furrow has stretched the adjoining gel layer, especially its superficial pigmented surface, and thus the pigment is pulled into streaky lines which extend into the furrow. The comparison with surface of fluid material is superfluous, since this involves a gel layer only, not a fluid one. "Chambers gives other evidence that this zone is liquid in his observation of Brownian motion and his micro-dissection experiments." Chambers' evidence that this zone is liquid does not hold for *Triturus* (Schechtman) and *Arbacia* (Marsland). "The stretched cortical material ('the primary furrow') has a lower concentration of pigment per unit surface and therefore, appears lighter than the rest of the upper hemisphere." The cortical material stretched by the contraction of the equatorial band naturally has a lower concentration of pigment per unit area than it had before. "A secondary furrow appears at about the center of the primary furrow. It gives evidence of addi-

tional stretching of its materials." The continued contraction of the band produces the secondary furrow. "The pigmented cortex bounding the lightly pigmented 'primary furrow' becomes the site of intense growth directed toward the egg interior." There is no growth. The continued contraction of the band deepens the furrow and pulls on the cortex adjoining the 'primary furrow', indicating that the cortical layer is in the gel and not in the fluid state. "Vitaly-stained marks placed in this position are drawn out into long delicate hair-lines as the furrow deepens." This is just what one would expect if the cortex is stretched or pulled down into the furrow.

"The streaming of the peripheral cytoplasm from the sides of the egg into the furrow, which has been described by a number of persons, is noticeably absent in the cortex. The streaming observed was in all probability a subcortical movement only, as has been suggested by Motomura also. This is supported by the recent work of Motomura, and of Brown, as well as of my own work, which shows that the cortex (of the *Strongylocentrotus*, *Arbacia*, and *Triturus* eggs, respectively) is a more or less rigid layer during cell division." I suspect that the "streaming of the peripheral cytoplasm" was invented to explain how the pigment granules moved toward the equator and down into the walls of the furrow. This flow, or surface current, as it has frequently been called, seemed to demand that the cortex change from the gel to the liquid state. Thus error leads to error. This flow, as already noted, is not a flow, but is a stretching and pulling down of the gel layer into the furrow.

"A reasonable explanation of the observed cortical growth, in view of its localized character, is that the increase may be due to an inhibition process, which of course, does not imply that the cortex becomes 'fluid'. Indeed, there are indications that the cortex of the furrow, excepting a small part near its tip, does not differ much in viscosity from the rest of the egg cortex. At least, the difference is not great enough to give rise to the characteristic surface contours of fluids in contact with relatively solid materials. It is well known that the swelling pressure of bio-colloids may attain high values under proper conditions, and the relatively fluid material which Chambers ascertained in the equatorial region of the cleaving eggs would offer little resistance. It is also possible that the growth of the furrow cortex is by intersusception of clear cytoplasm of sub-cortical origin; this might explain the part played by the cytoplasm which some workers have seen streaming toward the furrow. Both processes might be involved, since they are obviously not antago-

nistic." The moment one assumes that the advance of the furrow is due to cortical growth by an "inhibition process" or to a flow, insurmountable difficulties are encountered in explaining the streaks of the granules and of the dye materials. Schechtman recognized that "the mechanism of cell division has certain features in common with the sol-gel transformations generally regarded as important in the formation of pseudopodia in certain amebae", but his interpretation of the important facts which he contributed differ, as already noted, from mine.

The material and the type of experiment employed by Schechtman would seem to be unusually favorable for an analysis of cell cleavage. These experiments should be repeated again and again with a continuous series of marks across the equatorial line. One would expect that marks exactly on this line would be carried in the constriction band to the very bottom of the furrow.

The following quotations from Marsland (1939) on "The Mechanism of Cell Division" indicate that he recognized that an equatorial band played an important role in cell cleavage (p. 21): "At the time of cleavage the superficial protoplasm of the egg, especially in the region of the incipient furrow, becomes firmly set and displays the properties of a rigid gel." The hydrostatic pressure effect upon dividing egg cells (*Arbacia*) led him to the following conclusion (p. 22): "These results indicate that a gelation reaction by which the plasmagel in and near the walls of the furrows undergoes augmentation at the expense of the subjacent plasmasol may account for the formation and progress of the furrow. According to this view, the intrusion of the furrow is a process closely analogous to the extrusion of a pseudopodium." The following quotations from his discussion are significant (p. 20): "These experiments give strong support to the view that a gelation of the cortex of the egg, especially in the equatorial region where the furrow will form, plays an essential role in the mechanism of cell division." "Without question, just before the appearance of the furrow, this part of the protoplasm becomes firmly set and assumes a rigidity which is several times greater than before." (p. 21): "The view that a plasmagel girdle in the equator of the cell undergoes augmentation from the subjacent plasmasol on either side bordering the incipient furrow, and thus, is pushed inward toward the equator is further supported by the present experiments." (p. 21): "Although it is evident that the plasmagel over the entire surface of the egg undergoes a setting process just prior to and during cleavage, some evidence has

appeared in the present experiments, which indicates that a maximum rigidity is present in the equatorial region." "The role of the asters in the cleavage phenomenon remains for consideration. If the process which pushes the rigid walls of the furrow inward represents the interpolation of plasmagel which derives from the subjacent plasmasol, it is possible that the astral rays represent the lines of flow whereby this translocation of materials is accomplished."

If Marsland had used the words "pulled" and "pulls" instead of "pushed" and "pushes", his interpretations would agree perfectly with the idea that the equatorial girdle exerts contractile tension. The question as to how much the stretched plasmogel layer of the furrow is augmented by gelation of the subjacent plasmosol is a difficult one to answer. Schechtman's experiments show that the plasmogel is stretched, that is, the superficial part containing pigment granules and dye spots. It would seem probable, however, that there is some augmentation by gelation of the subjacent plasmosol. There is no necessity for assuming that the plasmosol adjacent to the furrow is augmented by a translocation of materials along the astral rays, unless the plasmogel consists of a different sort of protoplasm than that of the adjacent plasmosol, and there is no particular evidence for this.

DIVISION OF AMEBA

Chalkley in his paper on "The Mechanism of Cytoplasmic Fission in *Amoeba Proteus*" states that "general cell locomotion and cytoplasmic division may be intimately related as to mechanism." With this I entirely agree. He also states that "with the approach of the daughter nuclei to the surface, the elastic strength of the plasmagel layer will be sharply lessened in their immediate vicinity. The greater elastic strength of the plasmagel at the equator will result in the gradual constriction in this region. This will press the plasmasol into these weakened areas, and polar pseudopodia will protrude. With their attachment to the substrate, locomotion will be initiated, and the cell will elongate. The streaming of the cytoplasm will carry the nuclei outward, and their continued activity will maintain opposing polar regions of low tension in the plasmagel. The locomotion mechanism posited by Mast will thus be brought into play and maintained in opposite directions, and will result in the continual narrowing and stretching of the equator of the cell by traction of the daughter cells, until the cell is parted, and fission is complete."

If the elastic tension of the gel layer is due to a previous stretching by the osmotic pressure of the endoplasm, how can it contract in the equatorial region until it meets there to form the connecting stalk? Obviously, the gel layer could never have been stretched that much in this region, so the elastic tension or recoil cannot account for the constriction. The automatic contraction of a thickened or of a more viscous equatorial band of the gel layer is probably responsible for the cleavage of the ameba, as it is for the cleavage of cells. The stretching and final rupture of the connecting gel stalk is probably due to the ameboid movements of the daughter amebae in opposite directions and in part, to the contraction and solution of the stalk.

BLEB FORMATION

Most fibroblasts and sarcoma cells show bleb formation during late anaphase and telophase (Fig. 7). This has been noted by various authors. No adequate explanation of this common, but rather startling, phenomenon has been advanced. Perhaps they are analogous to the hyaline caps on the pseudopods of the ameba (Mast) and of the slime mold (Figs. 1-4).

Blebs arise rather suddenly during anaphase and telophase. They are usually free of granules. Occasionally, a stream of endoplasmic granules pours in. They evidently consist of clear fluid, which gathers under the interface membrane or a new membrane which enlarges as the blebs enlarge. The fluid does not appear to escape to the outside. It seems quite probable that increased pressure, exerted in the equatorial region by the contraction of the equatorial band of the gel layer during cleavage, forces endoplasmic fluid through the pores or interstices of local weak places in the gel layer and that these pores are too small to permit granules to pass.

Mast (1926, p. 420) states that "when a pseudopod is formed, the inner layer of the plasmagel liquefies locally, and the remaining portion stretches and bulges out, and at the same time becomes thin and porous. Liquid from the plasmasol passes through this porous layer of the plasmagel and collects under the plasmalemma forming a hyaline cap." The pores are too small to permit the granules to pass through. As already noted, almost precisely the same thing frequently occurs at the advancing ends of the slime mold. The hyaline caps are enormous as compared with the blebs of a fibroblast (Figs. 1 and 7), and consequently, offer better material for observations. When the contractile pressure at the posterior end

drives the fluid endoplasm forward, it pours into the advancing buds and stretches the thin gel layer. Suddenly clear, granule-free hyaline fluid appears beyond the granular layer and expands. It does not escape to the outside but is evidently enclosed by a thin invisible interface protoplasmic membrane, and probably also by a new thin gel layer.

BIBLIOGRAPHY

- BROWN, D. E. S. 1934. The pressure coefficient of "viscosity" in the eggs of *Arbacia punctulata*. *Jour. Cell. and Comp. Physiol.* 5: 335-346.
- AND D. A. MARSLAND. 1936. The viscosity of *Amoeba* at high hydrostatic pressure. *Jour. Cell. and Comp. Physiol.* 8: 159-165.
- CAMP, W. G. 1937. The structure and activities of myxomycete plasmodia. *Bul. Torrey Bot. Club* 64: 307-335.
- CHALKLEY, H. W. 1935. The mechanism of Cytoplasmic fission in *Amoeba proteus*. *Protoplasma* 24: 607-621.
- CHAMBERS, R. 1919. Changes in protoplasmic consistency and their relation to cell division. *Jour. Gen. Phys.* 2: 49-68.
- . 1924. *General Cytology*. Ed. E. V. Cowdry. pp. 294-295.
- . 1938. Structural and kinetic aspects of cell division. *Jour. Cell. and Comp. Physiol.* 12: 149-165.
- . 1938. Structural aspects of cell division. *Arch. exp. Zellforsch.* 22: 252-256.
- COMAN, D. R. 1940. Additional observations on positive and negative chemotaxis. *Arch. Path.* 29: 220-228.
- EDWARDS, J. S. 1923. The effect of chemicals on locomotion in *Ameba*. I. Reaction to localized stimulation. *Jour. Exp. Zool.* 38: 1-44.
- HEILBRUNN, L. V. 1940. Protoplasm and colloids. *Publ. 14, Amer. Assoc. Adv. Sci.*, pp. 188-198.
- HOWARD, F. L. 1931. Life history of *Physarum polycephalum*. *Amer. Jour. Bot.* 18: 116-133.
- HYMAN, D. H. 1917-18. Metabolic gradients in *Amoeba* and their relation to the mechanism of amoeboid movement. *Jour. Exp. Zool.* 24: 55-97.
- JACOBS, M. H. 1922. The effects of carbon dioxide on the consistency of protoplasm. *Biol. Bul.* 42: 14-30.
- KAMIYA, N. 1940. The control of protoplasmic streaming. *Science* 92: 462-463.
- LEWIS, W. H. 1931. Locomotion of lymphocytes. *Johns Hop. Hosp. Bul.* 49: 29-36.
- . 1931. On the locomotion of lymphocytes. *Anat. Rec.* 48: 52.
- . 1933. Locomotion of rat lymphocytes in tissue cultures. *Bul. Johns Hop. Hosp.* 53: 147-157.
- . 1934. On the locomotion of the polymorphonuclear neutrophils of the rat in autoplasm cultures. *Johns Hop. Hosp. Bul.* 55: 273-279.
- . 1938. On the role of a superficial plasmagel layer in division, locomotion and changes in form of cells. *Arch. exp. Zellforsch.* 22: 270.
- AND M. R. LEWIS, 1938. Studies on white blood cells. *Pub. No. 51, Cooperation in Research, Carnegie Institution of Washington*, pp. 369-382.
- . 1939. The role of a superficial plasmagel layer in changes of form, locomotion, and division of cells in tissue cultures. *Arch. exp. Zellforsch.* 23: 1-7.
- . 1939. Contorted mitosis and the superficial plasmagel layer. *Amer. Jour. Cancer* 35: 408-415.
- . 1939. Changes of viscosity and cell activity. *Science* 89: 400.

- . 1940. Some contributions of tissue culture to development and growth. *Growth Supp.*, pp. 1-14.
- MARSLAND, D. A. 1938. The effect of high hydrostatic pressure upon cell division in *Arbacia* eggs. *Jour. Cell. and Comp. Physiol.* 12:57-70.
- . 1938. The effects of high hydrostatic pressure upon the mechanism of cell division. *Arch. Exp. Zellforsch.* 22:268-269.
- . 1939. The mechanism of cell division. Hydrostatic pressure effects upon dividing egg cells. *Jour. Cell. and Comp. Physiol.* 13:15-22.
- . 1939. The mechanism of protoplasmic streaming. The effects of high hydrostatic pressure upon cyclosis in *Elodea canadensis*. *Jour. Cell. and Comp. Physiol.* 13:23-30.
- MARSLAND, D. A., AND D. E. S. BROWN. 1936. Amoeboid movement at high hydrostatic pressure. *Jour. Cell. and Comp. Physiol.* 8:167-178.
- MAST, S. O. 1923. Mechanics of locomotion in amoeba. *Proc. Nat. Acad. Sciences* 9:258-261.
- . 1926. Structure, movement, locomotion, and stimulation in Amoeba. *Jour. Morph. and Physiol.* 41:347-423.
- . 1926. Structure of protoplasm in amoeba. *Amer. Nat.* 60:133-142.
- . 1929. Mechanics of locomotion in amoeba proteus with special reference to the factors involved in attachment to the substratum. *Protoplasma* 8:344-377.
- . 1931. Locomotion in amoeba proteus (Leidy). *Protoplasma* 14:321-330.
- SCHECHTMAN, A. M. 1937. Localized cortical growth as the immediate cause of cell division. *Science* 85:222.
- SEIFRIZ, W. 1938. Recent contributions to the theory of protoplasmic structure. *Science* 88:21.



PHYSICAL ASPECTS OF PROTOPLASMIC STREAMING

NOBURÔ KAMIYA

I. INTRODUCTION

Protoplasmic streaming is maintained by a motive force which overcomes the viscosity of protoplasm, and in so doing imparts a specific velocity gradient to it. Until now the magnitude of this motive force was not known, nor was it known how it changes.

The development of a suitable technique has made it possible to measure the absolute value of the motive force generated in protoplasm.

The experiments were done on the plasmodia of the Myxomycete, *Physarum polycephalum*. As is well known, the plasmodium of a Myxomycete consists of stationary protoplasm of higher viscosity and less viscous flowing protoplasm, both of which are readily interconvertible. Streaming is accompanied by changes in the contour of the plasmodium as a whole. These two processes, streaming of the fluid, inner protoplasm, and change in contour of the whole body are so closely related that one movement necessarily involves the other. One remarkable feature of the protoplasmic streaming in Myxomycetes is its comparatively great speed, and especially significant is the characteristic reversal in direction of flow. The velocity of flow changes according to the rhythmic pattern.

Before proceeding with the subject matter of this paper, it would seem pertinent to state briefly the behavior of protoplasmic flow under locally applied mechanical pressure, which behavior was so characteristic as to lead me to undertake the experiments reported here.

A cover-glass culture of a plasmodium is inverted on a glass slide with enough water to keep the protoplasm from touching the slide. Then, a certain point on the cover glass is gently pushed down by means of a bent needle affixed to a micromanipulator. When some part of a plasmodium thus mounted first touches, under applied pressure, the surface of the slide, the movement of the interior, fluid protoplasm is strikingly affected. As the mechanical pressure is exerted unequally upon the plasmodium, because of the uneven surface of the plasmodium, and the fact that pressure is applied only

at one selected point of the cover glass, the fluid protoplasm is pressed out of the parts to which the pressure is applied and goes to those parts which are free from pressure. By this simple procedure the spatial relations of the fluid protoplasm can be observed to change very readily in the network of strands or in the branched courses throughout the fan-like expanses of gelatinous protoplasm. The movement of the protoplasm induced by the mechanical pressure is superimposed on the normal flow. Therefore, when applied mechanical pressure affects the natural flow, a temporary acceleration, retardation or reversal in direction takes place, after which the protoplasm takes its normal course.

Such superimposed modified flow, controlled by mechanically applied pressure, causes no injury to the protoplasm. When the mechanical pressure is removed, the surface layer of the protoplasm takes on its original form again, presumably because of its elasticity, and the interior fluid protoplasm, which had been displaced, returns. By careful control of the screw of the micromanipulator, a spasmodic movement, as well as a rebounding of the interior protoplasm, can be repeatedly produced, without giving rise to any observable disturbances, provided that the applied pressure is not so strong as to cause a structural disturbance of the protoplasm, such as was observed by Balbach (1936).

From the simple experiment above described one can say that the streaming of the interior more fluid protoplasm is modified in a manner directly dependent upon the pressure applied. These observations verify the conclusion of Hilton (1908), who applied mechanical-pressure by the tapping of a needle upon a small piece of cover glass placed outside of the microscopic field and covering a part of the body of a plasmodium. The application of localized pressure can also be made with a blunt glass microneedle by pressing it directly against the surface of the plasmodium, as reported by Camp (1937).

The fact that a slight, unequally applied pressure produces practically no injury to protoplasm, yet induces artificial flow, suggests the possibility that protoplasm is normally driven passively by a pressure difference established in the system of a plasmodium. Curiosity about such a behavior of protoplasmic flow led me to perform further experiments in which air-pressure was used instead of mechanical-pressure.

If each of two masses of protoplasm connected by an unbroken

strand are placed in separate air-tight compartments, thus permitting the protoplasm to flow freely from one compartment to the other, and if the air-pressure in one of the compartments is modified, then the protoplasmic streaming in the connecting strand will be modified accordingly. The tendency to flow from one compartment to the other is thus opposed by a counter-pressure.

In order to realize such an experiment in practice, the following technique has been arrived at after repeated modifications and improvements.

II. METHOD

(a) *Preparation of the Material.* The stock culture of *Physarum polycephalum* is grown on moist filter paper and fed powdered oats (Camp, 1936). Then a tiny bit, say 1/20 gram, of protoplasm is removed from the stock culture and placed on the surface of nutrition-free (tap water) 2 per cent agar in a Petri-dish. After an hour or two the protoplasmic mass spreads out into a thin round sheet, and later into a network or branched system of vigorous strands with a wavy advancing margin or several peninsula-like expanses. When a comparatively straight part is found among these vigorous strands, a small rectangular sheet of agar (ca. 15×25 mm., 1 mm. in thickness), including the selected protoplasmic strand, is cut out. This rectangular sheet of agar, containing a strand of protoplasm lying parallel to its longer sides, is placed on a glass slide of 24×60 mm. (Fig. 1A).

The next step in the preparation is to put new blobs of protoplasm from the stock culture on to both terminals of the strand. The strand and the two blobs of homospecific protoplasm soon fuse, and the three separate parts now unite to make one dumbbell-shaped plasmodium (Fig. 1B).

Further procedure involves inverting this glass slide with the agar sheet and the dumbbell-shaped plasmodium on to a specially constructed double chamber, shown in Figure 2. The glass slide covers the top of this chamber. As shown in Figure 2, two glass partitions (*p*) 1 mm. thickness, are fastened vertically across the chamber 6 mm. apart from each other. As the height of these partitions is about 1.5 mm. less than that of the side wall of the chamber, there remains just this much distance between the upper edge of the glass partitions and the under surface of the slide after the latter is inverted on the top of the chamber. This space will partly be occupied by the connecting strand of the protoplasm and by the thin sheet of agar that

adheres to the slide. The small space between the two partitions is filled with a 2 per cent agar sol at about 40°C., the meniscus of which is higher than the upper edges of the partitions. Before the agar is transformed to a gel, which occurs at about 35°C., the glass slide with the agar sheet and the dumbbell-shaped plasmodium is inverted over the chamber. As the agar is still in a sol state, it fills up all the spaces to be closed without injuring the delicate strand of protoplasm.

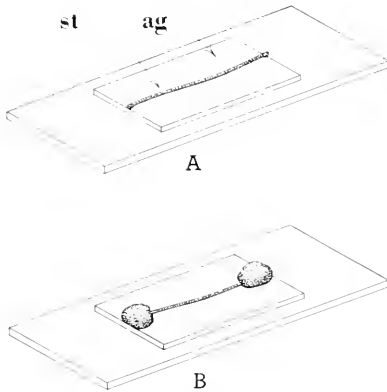

FIG. 1. A. An agar sheet, *ag*, with a protoplasmic strand, *st*, placed on a glass slide. B. Two protoplasmic masses placed on the agar sheet at both ends of the strand.

After this procedure the 2 per cent agar soon gelatinizes, and the chamber is divided into two air-tight compartments. Figure 3A shows a cross-section through the double chamber at the agar wall and Figure 3B, its longitudinal section at the middle part.

Protoplasmic flow is stopped temporarily because of mechanical and thermal disturbances, but it soon recovers. Meanwhile, the two blobs of protoplasm at both ends of the strand, which are in the separate compartments, spread out, having already fused with the connecting strand (Fig. 4A).

The observation chamber is now put, with rubber gaskets, between two metal frames which are tightly joined together by means of four screws. Thus is the preparation of the material accomplished (Fig. 4B).

It is a favorable characteristic of agar to have a large hysteresis range, within which agar can exist either as a sol or as a gel. Two hardly compatible technical requirements are thus fulfilled; namely, the two separate compartments are kept air-tight against a considerable pressure difference between them, and at the same time the cross-wall does not block the flow of protoplasm in the delicate connecting strand. Furthermore, agar is sufficiently transparent to permit observation of the flowing protoplasm in the connecting strand. It is by means of light transmitted through the agar wall that the observation is made. Though it is not absolutely necessary for simple observation of flow, one can get a clearer microscopic image of the connecting strand if a rectangular prism of glass of suitable size is mounted in the agar wall between the two partitions.

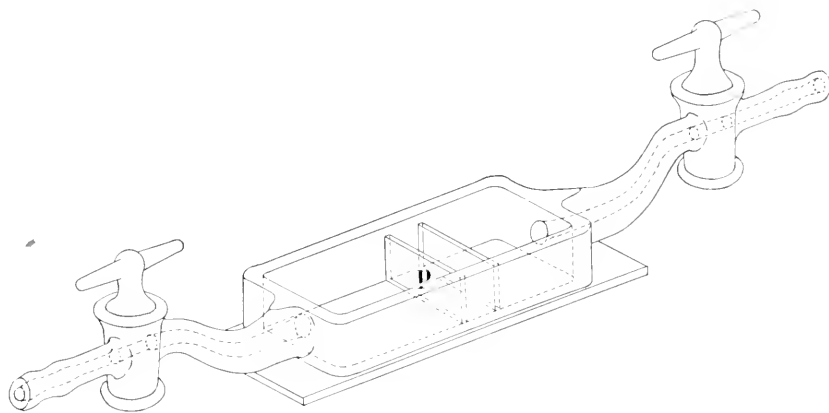

FIG. 2. Observation chamber with two partitions, *p*.

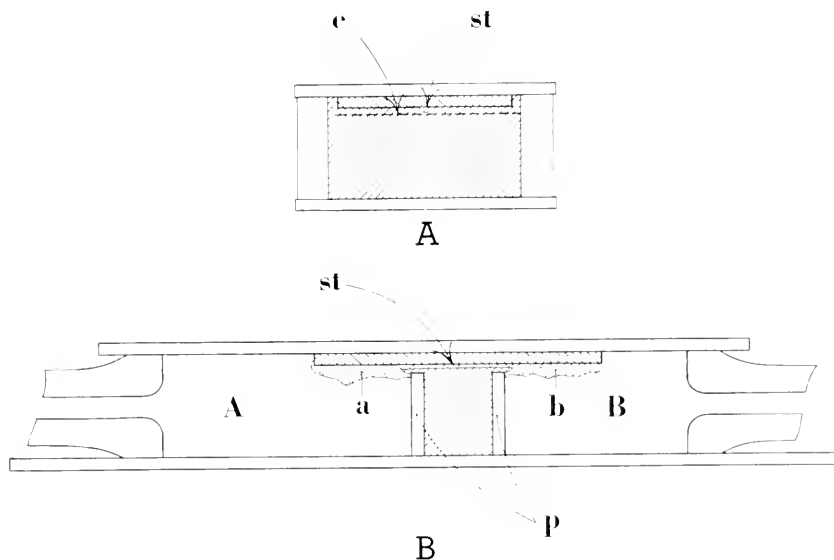

FIG. 3. A. The cross section through the prepared observation chamber at the agar wall. The broken line, *e*, shows the upper edges of the two glass partitions. B. The longitudinal section through the middle part of the same chamber divided into the two compartments, A and B. The protoplasm, *a* and *b*, in the separate compartments and the connecting strand, *st*, are dotted. The shaded parts in figures A and B represent agar. That part in which the hatching runs from upper left to lower right represents an agar sheet adhering to the glass slide, whereas that part in which the hatching runs from lower left to upper right represents agar poured between the two partitions, *p*, just before inverting the slide over the chamber, and which then serves to seal the chamber.

(b) *Control of Pressure.* In order to establish a pressure difference between the two compartments, the opening of one compartment is connected with a passage leading to an aspirator tube and a manometer, while the opening of the other compartment is kept open, as shown in Figure 5.

Aspirator *As*, used for controlling the air-pressure, is made of a thick, rubber tube, the middle part of which is placed between two solid metal plates (shaded in Fig. 5). The upper plate is equipped

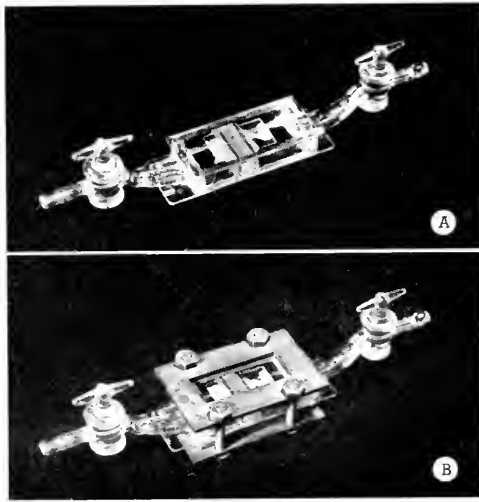

FIG. 4. A. The double chamber, after inverting the glass slide with the agar sheet and the material. The thin strand of protoplasm runs through the agar wall. B. The completed preparation: finished observation chamber fastened between metal frames with two rubber gaskets.

so that it can be moved gently up and down by means of a screw *S*, with the result that the inner volume of the rubber aspirator tube can be controlled most exactly.

After opening the stop-cock *SC*, the aspirator is pushed down gradually by tightening the screw *S*. The air pushed out by this depression is let off at the stop-cock *SC*. When the aspirator tube is pushed down to about half of the stroke, the stop-cock *SC* is closed. The whole system consisting of compartment *B*, the aspirator *As* and the manometer *M* is now air-tight. If the screw *S* is tightened farther, the inner pressure of the entire system is increased, i.e., the pressure of compartment *B* becomes higher than that of compartment *A*. If, on the contrary, the screw *S* is loosened, being turned in the opposite direction, then the aspirator tube will expand because of the elasticity of its rubber wall. The inner pressure of the system, including compartment *B*, becomes, therefore, lower than atmospheric pressure. The pressure of compartment *B* can thus be controlled to any desirable degree within the necessary range, both in regard to positive and negative compression, by means of a single screw. The range desired is usually between + and - 30 cm. of water.

The pressure difference between compartment *A* and compartment *B* is ascertained by a water manometer *M* of 50 cm. in height.

Compartment *A* and compartment *B* will, hereafter, be referred to as *A* and *B* for the sake of simplicity.

III. EFFECT OF PRESSURE DIFFERENCE ON PROTOPLASMIC STREAMING

When there is no pressure difference between *A* and *B*, streaming takes place normally along the connecting strand of the prepared

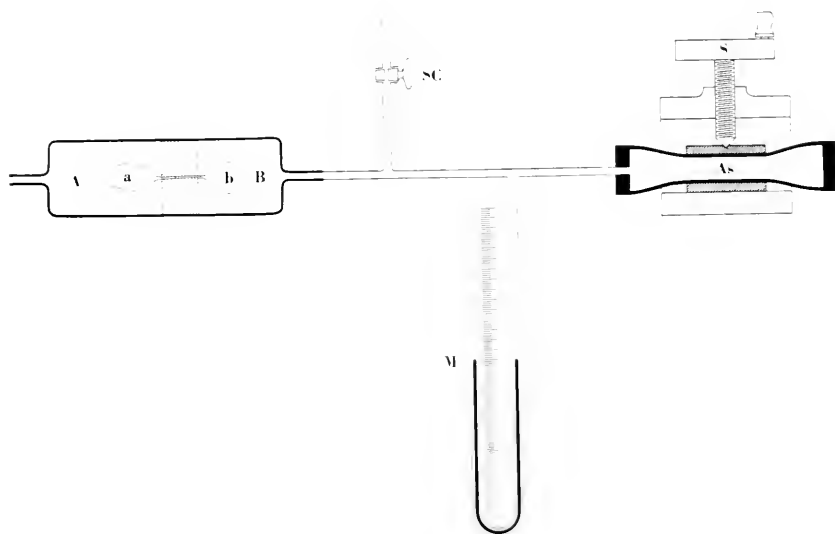

FIG. 5. Diagram showing the arrangement of the whole system consisting of the double chamber having two compartments, *A* and *B*, rubber aspirator, *As*, controlled by screw, *S*, manometer, *M*, and stop cock, *SC*. Agar wall is shaded. Protoplasm in *A* and *B* is designated *a* and *b*, respectively.

plasmodium which penetrates the agar wall, showing the usual rhythmic reversal in direction of flow. But when the two compartments are subjected to a pressure difference, the velocity of the streaming, which otherwise would proceed normally, is modified in accordance with the extent and direction of the pressure difference established (Kamiya, 1940).

Let us suppose the protoplasm to be flowing from *a* to *b* (Fig. 5). If a slightly lower pressure causing suction is applied to *B*, then the flow of the protoplasm along the connecting strand from *a* into *b* is accelerated.

During the time in which the protoplasm flows in the opposite direction, namely from *b* to *a*, the air-pressure of *A* must be lowered below that of *B*, if the flow is to be accelerated. In practice, however, the pressure of *B* is increased instead of decreasing the pressure of *A*, in order to establish a pressure difference in this direction.

Protoplasmic streaming can be artificially speeded up in this way to maximum velocities which are beyond those of natural conditions. By establishing a pressure difference of, say 20 cm. of water, so as to cooperate with the motive force developed in the protoplasm, one can readily increase the velocity to more than 2 mm. per second through a connecting capillary of 200 μ inner diameter. The normal maximum is about 1 mm. a second.

Next must be considered the effect of a pressure difference, which is established so as to oppose the protoplasmic force. In this case, as expected, the velocity of the flow is retarded. When, for instance, the protoplasm flows from *a* into *b*, the volume of the protoplasm *b* is, of course, increased. If the air-pressure of *B* is made higher than that of *A*, then it is clear that a part of the motive force generated in the protoplasm must be used in the work required to bring about the expansion of the protoplasmic volume against the higher pressure which has been artificially applied. Should the pressure applied be stronger than the protoplasmic force developed in the plasmodium, then the forward-moving protoplasm is forced backwards. In other words, the motive force of the protoplasm is overcome by the application of a counter-pressure.

If, now, the protoplasm is flowing as before, namely from *b* to *a*, a lower pressure must be applied to *B*, if the flow is to be retarded or reversed.

From the foregoing description it is evident that by changing the pressure of *B* both on the + and - sides of the manometer, the direction and speed of the protoplasmic flow along the connecting strand can be accurately controlled. Flowing protoplasm thus controlled is driven by a resultant force which is the algebraic sum of the shearing stress developed in the protoplasm and that caused by the pressure difference artificially induced.

One would expect that artificial acceleration, retardation, or reversal of flow would induce serious disturbances in the protoplasm, but a wholly normal flow is resumed as soon as the pressure is released. It is rather surprising that such a remarkable modification of the flow does not result in any pathological abnormality.

IV. MEASUREMENT OF THE MOTIVE FORCE

By controlling the air-pressure in *B*, it is possible to oppose the motive force in such a way as to hold the protoplasm at a standstill. The counter-pressure, which is just sufficient to prevent the protoplasm from flowing either forward or backward, is a measure of the absolute value of the motive force responsible for the streaming of the protoplasm. This counter-pressure has been termed "balance-pressure" (Kamiya, 1940).

The range of the absolute value of the balance-pressure is usually within 20 cm. of water. But this value, as will be shown later, varies from plasmodium to plasmodium of the same species, and from rhythm to rhythm of the same plasmodium under the same external conditions. The maximum value so far encountered was 30 cm. of water.

Since the motive force developed in the protoplasm does not remain constant, the balance-pressure must be adjusted accordingly, if the protoplasm is to be kept immobile. In order to do this, one must constantly watch the direction tendency of the moving protoplasm at some definite part of the connecting strand. As soon as the equilibrium between the natural motive force and the balance-pressure is broken and, consequently, the tendency of the flowing direction is recognizable, the counter-pressure is increased or decreased, as the case may be, so that the protoplasm under observation always stays at the same place. With a little practice and skill this procedure enables one to restrict the movement of the protoplasm within a range of 50 μ . So sensitive is the movement of the protoplasm that the slightest deviation from the balance point will induce movement in an 8 mm. strand.¹

When the protoplasm is kept motionless at a definite point in the connecting strand, there is no longer a mutual transference of the protoplasm between the two parts of the plasmodium. However, it must be noted, that suspension of flow of the protoplasm under observation does not mean the cessation of movement elsewhere in the plasmodium. Local displacement of the interior protoplasm,

¹This fact does not, however, necessarily mean that protoplasm has no "yield value," since there is a possibility that displacement due to the slightest shearing stress may be ascribable to an elastic deformation. The inherent motive force which cannot be eliminated under normal conditions makes it impossible to determine whether or not the slightest shearing stress is capable of allowing protoplasm to undergo continuous deformation (flow), or whether a certain amount of critical shearing stress is necessary to make protoplasm flow.

though restricted, continues to take place within the protoplasmic expanses at both ends of the connecting strand, which are spread into more complicated forms than those schematically shown in Figure 5, *a* and *b*.

Morphologically, the two parts of protoplasm in the different compartments are still connected, but functionally, they behave just as if they were two independent plasmodia, as long as movement in the connecting strand is suspended.

As in the case of an artificial change in velocity, the cessation of protoplasmic flow for a period of time by uninterrupted adjustment of the balance-pressure also causes no visible abnormalities in the protoplasm. Nor is there any indication of physiological disturbance even after more than two hours, during which time the flow is stopped. When the balance-pressure is released by opening the stop-cock (*SC* in Fig. 5), the protoplasm in the connecting strand immediately starts to flow. The velocity depends upon the inherent motive force in the protoplasm at the moment of release.

V. RELATED PROBLEMS

The experiment reported above gives a means of attacking problems covering important subjects of protoplasmic research.

The Capillary Method as a New Means of Measurement of Protoplasmic Viscosity.

It is impossible to make slime mold protoplasm flow through a glass capillary without fatal results, but through its own capillary, such as a connecting strand, the protoplasm can flow quite normally. A dumbbell-shaped plasmodium consisting of its own capillary and two "reservoirs" of protoplasm is, as it were, in itself a capillary viscometer. If one releases a balance-pressure of known value and compares the velocities of protoplasmic flow at the time of release in a treated and a control plasmodium, one can estimate the relative viscosity of the interior flowing protoplasm under controlled conditions. As the inner diameter of the connecting strand is not kept exactly the same, some correction for this is needed.

The diameter and length of the connecting strand are both determinable; the motive force responsible for the flow can now be measured. By determining the velocity of protoplasmic flow through the capillary of known diameter and length under known shearing stress (motive force), it seems not impossible to evaluate even the absolute viscosity of protoplasm by applying Poiseuille's Law.

In passing, another point may be mentioned, namely, the

possibility of causing protoplasm to flow under various rates of shear. It may be that the capillary method will help throw some light on the study of the anomalous, or non-Newtonian, flow of protoplasm which is at the present time based upon a complex mixture of fact and theory.

Motive Force versus Viscosity.

As remarked by Ewart (1903, 61), the speed of the flow is dependent upon viscosity as well as upon the motive force which drives the protoplasm. In fact, streaming must be considered in terms of these two variables. There has been, however, no method developed to measure the motive force, which is a fundamental factor in the mechanics of protoplasmic flow. Heilbrunn (1937, 243) pointed out the difficulty arising from an attempt to interpret the result of experiments on protoplasmic streaming, since it was impossible to decide to what extent a change in speed is due to a modification of the motive force, and to what extent it is due to a change in the viscosity of the protoplasm. It is hoped that the experiments reported above may make some contribution to analytical studies on the effect of physical and chemical agents on protoplasmic streaming. Some of the observations made that might prove to be of value in this respect, are as follows: ascertaining, when an external agent has been applied that the protoplasmic flow is stopped because of an immense increase in viscosity rather than a dying away of the motive force; or ascertaining that the situation is different, namely, the flow is retarded because of a reduction in motive force rather than an increase of the viscosity.

VI. GRAPHICAL REPRESENTATION OF THE MOTIVE FORCE—
"DYNAMOPLASMOGRAM"

In section IV, it was stated that the balance-pressure must be adjusted continuously in order to keep the protoplasm quiet. Since the balance-pressure is a measure of the motive force, an increase and decrease of it must mean a parallel change in the motive force. Changes in the balance-pressure reveal autonomic variations of the mechanical forces liberated in the vital system.

In order to determine in what manner and to what extent the motive force changes in relation to time, instantaneous values of the balance-pressure were read at 5-second intervals. The recording was made by another observer, who watched the manometer.² The

² I am indebted to Miss A. Cantlin, Mr. J. Evans, Mr. R. Ferlauto, Mr. M. Ross, Miss M. Uraguchi and others for their kind assistance in the experiment.

5-second sound signal was given by an apparatus operated by a synchronous motor whose speed was governed by A.C. cycle constancy. By plotting a series of these succeeding values as ordinates against time as abscissas, undulating curves were obtained which faithfully portray the distinguishing features of the changes which the motive force undergoes in accordance with the autonomic scheme of the protoplasm. The graphs thus obtained, which shall be referred to as "dynamoplasmogram," give a complete pattern of the rhythm in protoplasmic activity. All the characteristics of rhythm such as wave form, frequency, polarity, and amplitude are portrayed by graphical representation.

So striking and impressive is the rhythmic flow of the protoplasm, that one is inclined to view the streaming as the significant thing, when actually it is only the visible end-effect of the motive force. The speed of flow is a function not only of the motive force, but also of various factors which are not kept constant during the rhythmic flow, such as thickness of the strand, viscosity,³ etc.

Holding protoplasm quiet artificially is a method which has decided advantages. By such means, the motive force can be measured directly under statical conditions, thus eliminating numerous factors which would possibly exert a disturbing influence. It was possible, through the development of special techniques, to measure continuously rates of flow and volume of protoplasm transported. When these values are plotted against time, they yield rhythmic wave patterns comparable to the dynamoplasmograms. However, the dynamoplasmograms will be considered exclusively as a standard of rhythm in the present paper, because the motive force when thus measured is purer in respect to the rhythmic functioning of protoplasm than any other observable phenomenon.

In order to understand a dynamoplasmogram, it is necessary to remember that the protoplasm is being opposed and kept at a standstill. In other words, what one observes is quiet, but what one measures is a motive force which still functions, i. e., the rhythm continues. The value of the balance-pressure at any point in the time scheme represents the motive force responsible for the flow which would have taken place were the balance-pressure removed at that moment. In virtue of the high sensibility of protoplasmic mobil-

³ Viscosity may not remain constant under different rates of shear (velocity gradient) during the normal rhythmic flow, since protoplasm is thought to be non-Newtonian in nature (Pfeiffer, 1936, 1937).

ity to pressure variations, the experimental data obtained would seem to have a high degree of accuracy.

The measurements were made at room temperature (22° – 25° C.), which deviated not more than 0.5° C. during the time of experiment.

In all the following figures, the abscissas represent the balance-pressure applied to *B* (Fig. 5), but they are equal to the vital motive force, if the direction from *a* to *b* is regarded as positive and the opposite direction, viz., from *b* to *a* as negative.

Figure 6 represents the usual and most regular change in the motive force. The undulating curve is beautifully smooth and the points plotted are almost in line. The points at which the wave passes through the base line, where the balance-pressure is zero, correspond, if the protoplasm were free to flow, to the reversal moments of the flowing direction. According to the concept generally accepted, one rhythm involves the duration of time for a complete progression and regression of the protoplasmic streaming (cf. Vouk 1910, 1913). Therefore, graphically, the distance on the base line between alternating reversal points, including both + and – sides of the wave, denotes, in a general sense, “one” complete rhythm. Except for the wave groups at the beginning and at the end of the wave train, the distances between any two adjacent maxima or adjacent minima have approximately constant intervals (periods) averaging 93.7 seconds, and there is also mostly one point of inflexion between the consecutive maximum and minimum of the curve. The wave looks, on the whole, fairly regular and bears considerable resemblance to the sinusoidal wave.

The wave in Figure 6 does, however, show slight fluctuations, which indicate that there is quantitatively no constant factor in respect to amplitude, wave-form, etc. At the beginning and end of the wave train, the amplitude diminishes conspicuously, and the wave no longer sustains a regular form; whereas, in the middle part of the train, the waves swell. When one considers the “envelope”, or imaginary margin, of this wave train, it assumes the form of a long spindle, the middle portion of which is six times as wide as the ends.

It is extremely interesting to note that the change in amplitude often takes place with considerable regularity, i. e., after a decreasing amplitude period the wave swells out gradually to a maximum, and after the lapse of a certain period of time, the magnitude decreases again and is followed by the next increasing period. Figure 6 shows simply one long “waxing” period between two “waning”

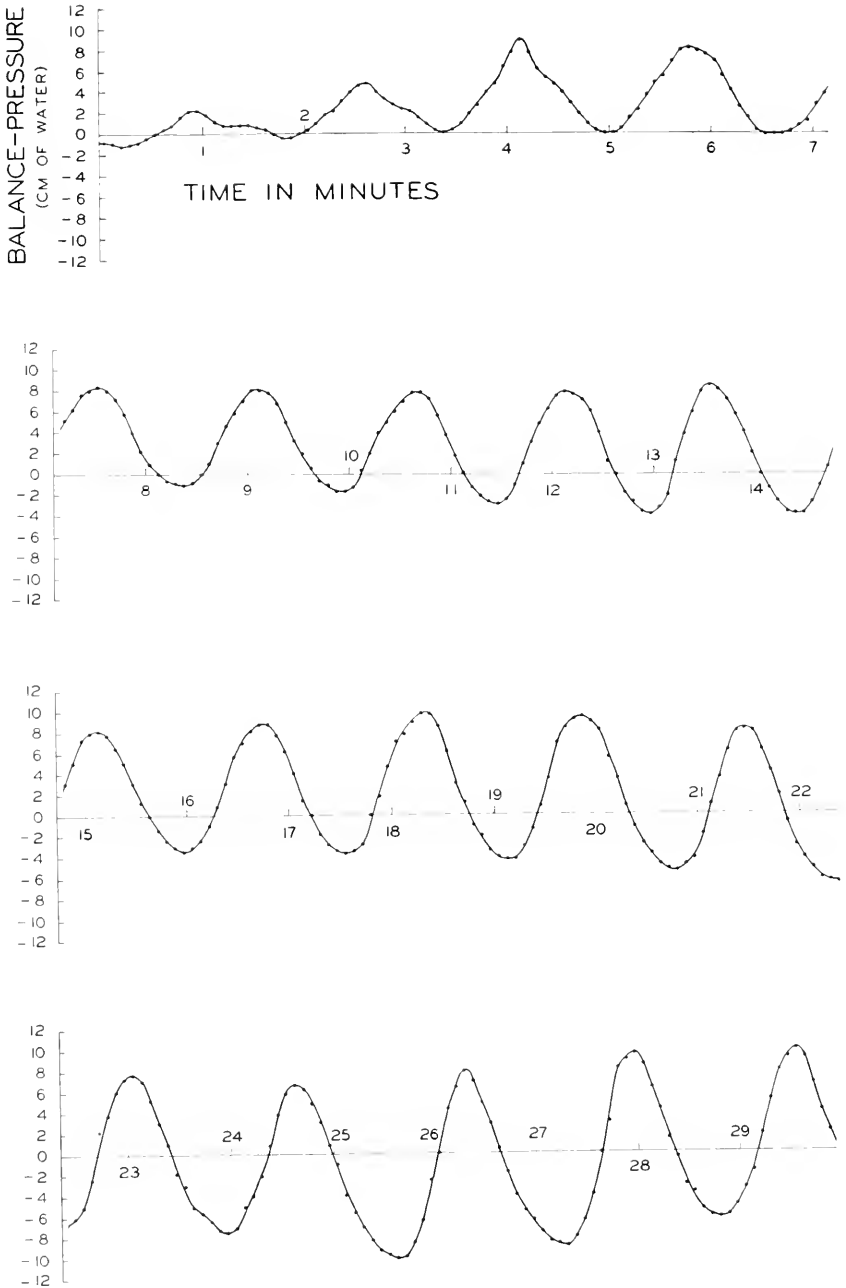

FIG. 6.

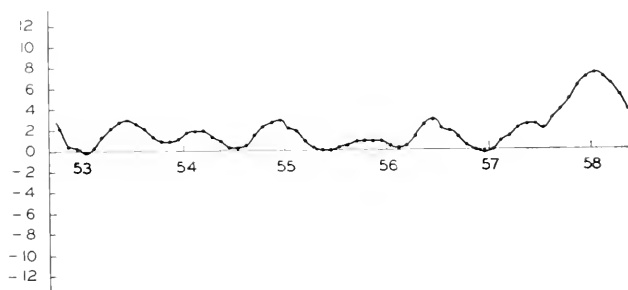
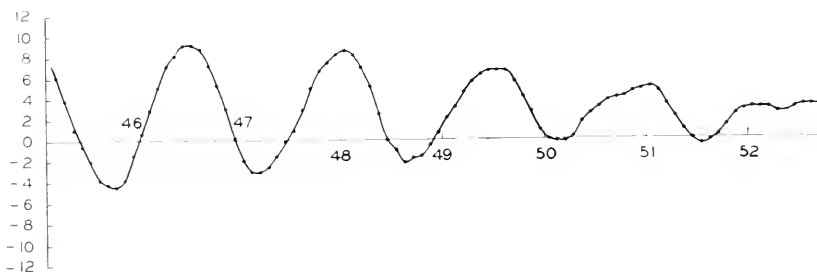
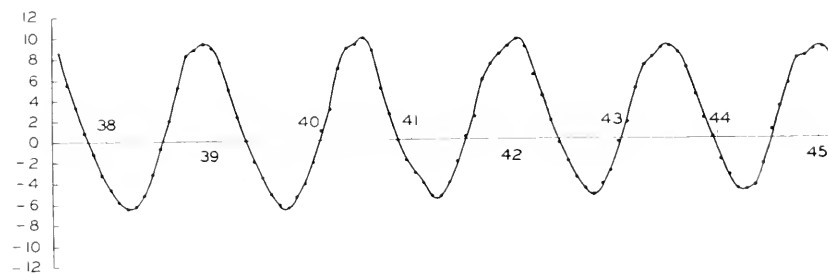
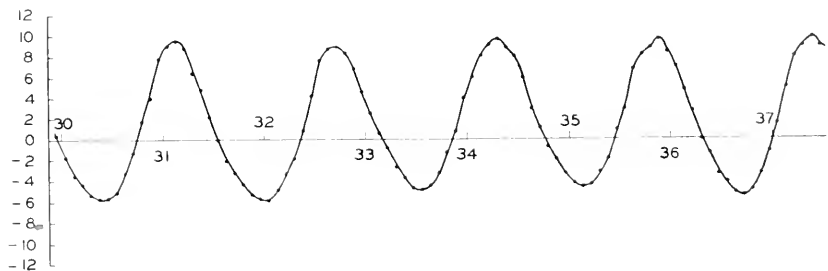

FIG. 6—continued.

periods. The alternation of waxing and waning periods is better illustrated in Figure 7. During the periods of 9–13, 21–25, 32–36, and 42–46 minutes on the abscissa, the waves have an increased amplitude, and the shape approaches the harmonic wave. Between any two of these adjacent wave groups, there are periods of decreased amplitude where the wave form is irregular and clonic. The interval of waxing and waning periods in Figure 7 remains approximately constant for about 11 minutes; that is, the wave undergoes a similar change in amplitude every 11 minutes. This is, however, not a general rule, but applies only to the plasmodium used in this experiment. The duration of the waxing and waning periods of a plasmodium, if any, differs from specimen to specimen; indeed, it changes in one and the same plasmodium, as will be considered later.

Figure 8 shows a pattern similar to Figure 7, but the increase and decrease of the amplitude takes place more frequently. Here the irregular and clonic portions of the curve, which correspond to the waning periods in the foregoing graphs, appear every 6–7 minutes, preceded and followed by only two or three smooth and reinforced waves. The patterns of the clonic parts of the waves are not similar to each other.

From the graph discussed above (Figs. 7 and 8), it is evident that the waves undergo pronounced variations in amplitude and that these variations occur according to a rhythmic pattern. It must be noted, however, that the regular alternation between waxing and waning periods can not be observed in all specimens of plasmodia. The waxing and waning of the wave train often take place at varying intervals and to a varying extent. Figure 9 is an example of this. The wave magnitude changes from rhythm to rhythm, but tonic and clonic changes occur at irregular intervals. During the periods 0–6, 26–29, 55–70 minutes on the abscissa, the waves show a decrease in magnitude. A similar tendency is also recognized, though less prominently, during 16–19 minutes on the abscissa. On the other hand, the wave groups between two of these depressed portions of the curve are comparatively tonic. The constancy of the waxing and waning periods is not maintained here.

The foregoing graphs show that the motive force undergoes pronounced variations not only in its magnitude, but also in its wave form during the rhythmic succession of vital processes. Sometimes a characteristic form appears repeatedly throughout several rhythms. Even when an exactly similar wave form is not repeated, the change is generally transitional in the course of the successive waves.

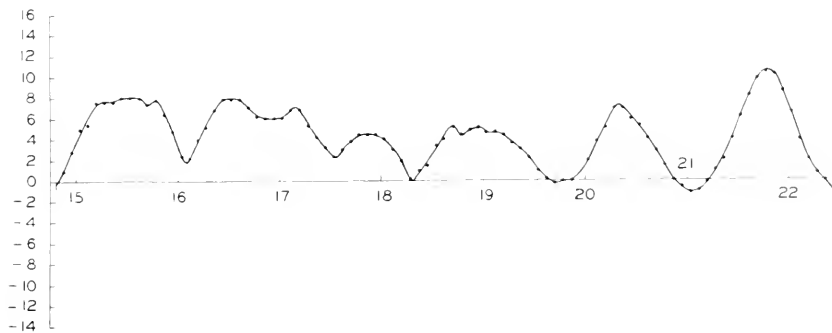
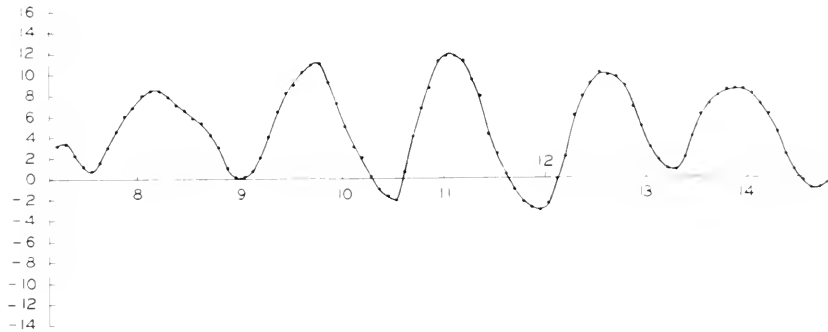
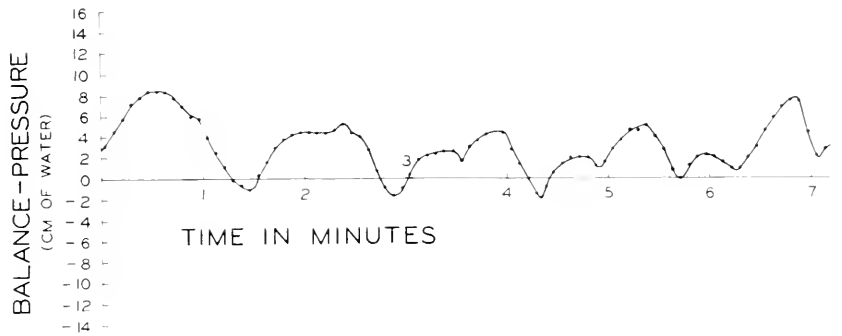

FIG. 7.

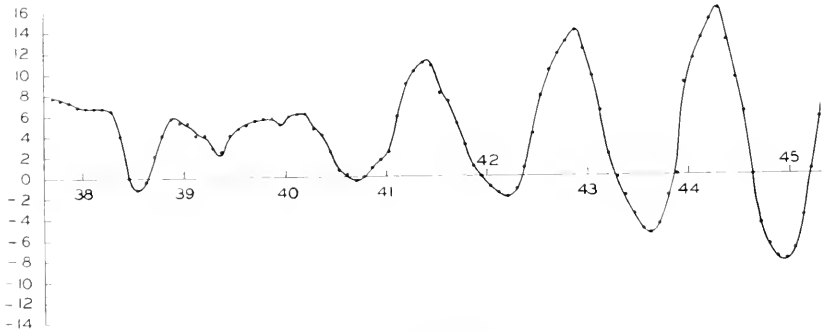
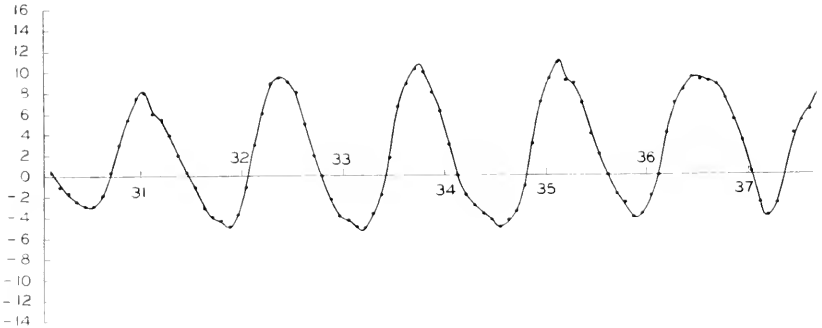
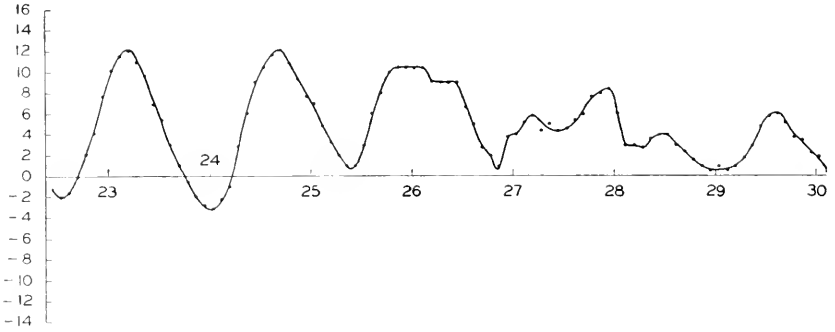

FIG. 7—continued.

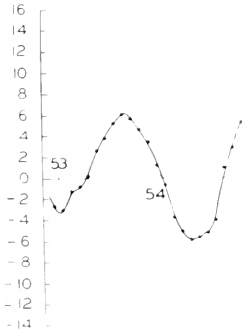
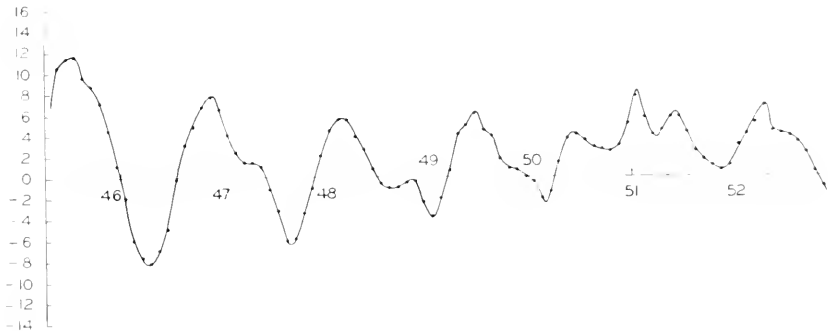

FIG. 7—continued.

In Figure 10 the form and amplitude of each successive wave is almost the same. As the wave repeats nearly the same details of the change, it is approximately periodic within this range of the time scheme. It is noteworthy that the curve shows a special concavity following each trough and also, a somewhat similar concavity following each crest. The wave as a whole is not symmetric, but it does show a symmetric character. The rhythmic interval (period) is only 84 seconds. The dash-dot line, which will be considered in the following section, cuts the wave into two equal + and - areas.

In Figure 11 the wave form is very characteristic. The wave rises suddenly, then falls rather suddenly at first, and later more gradually until the trough is reached. Nevertheless, the form of each rhythmic pattern is very similar, although the magnitude of the wave gradually

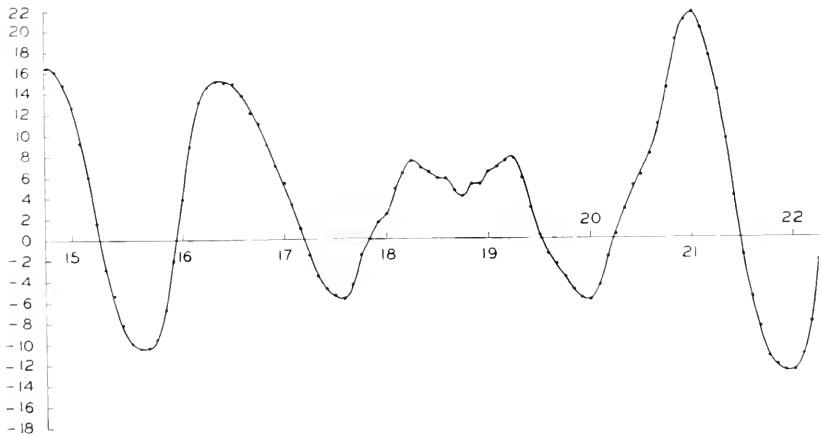
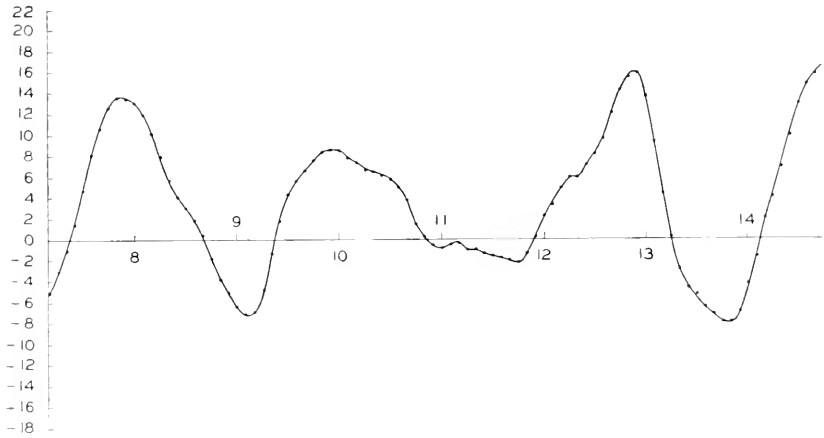
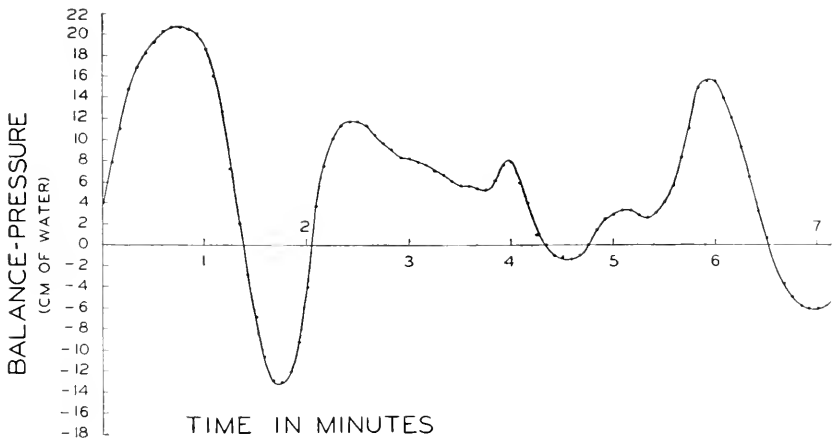

FIG. 8.

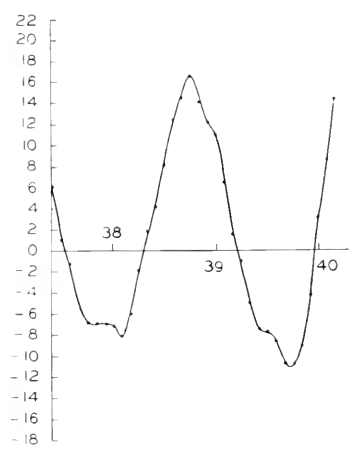
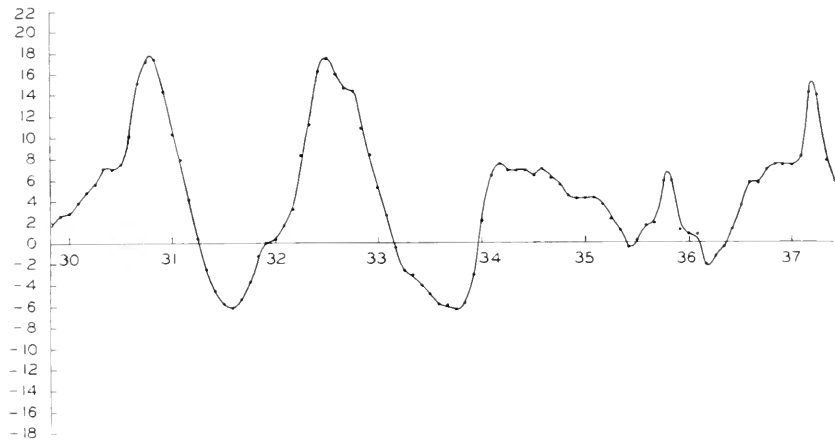
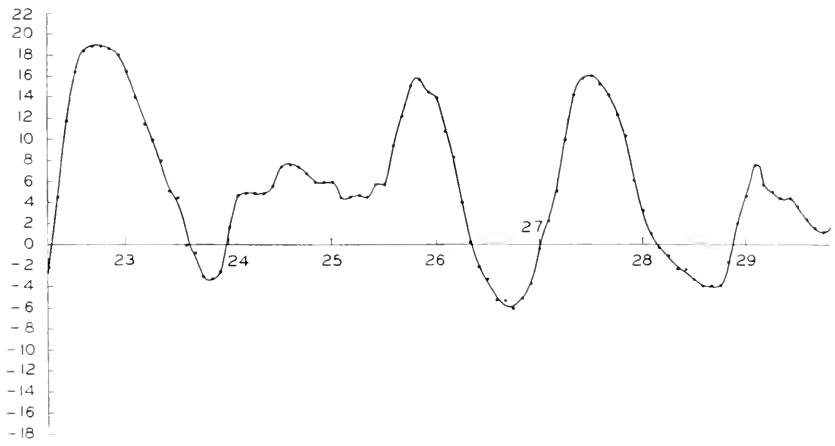

FIG. 8—continued.

decreases in this case. The distance between any two adjacent maxima and minima of the waves is nearly constant for about 117 seconds.

Figure 12 shows another pattern of the rhythm. In this figure, the crest is acute, while the trough is flat. The magnitude and the period (ca. 132 seconds) are greater than those of Figure 11. Though the amplitude diminishes gradually, as in Figure 11, the wave form remains similar in each rhythm. The dash-dot line and the dotted waves will be taken up later.

VII. GENERAL CHARACTERISTICS OF DYNAMOPLASMOGRAMS

The graphs presented in this paper are some of the representative cases of more than 40 wave trains so far obtained in my experiments with different specimens. By inspecting these graphs one can summarize their general features as follows:

1. The pattern of the curve undergoes variations from rhythm to rhythm in the same specimen under the same external conditions.
2. A marked change in amplitude sometimes recurs at regular intervals (Figs. 7 and 8), but this regularity is not always maintained, even though the waves continue to change amplitude (Fig. 9).
3. A similar wave form often reappears throughout several successive rhythms (Fig. 10). Changes in the wave form as well as in amplitude are transitional (Figs. 11 and 12).

These general characteristics of the curve are, however, open to possible question. One may wonder whether or not the peculiar pattern of the wave has anything to do with a "grafted" plasmodium, in which three separate portions (two protoplasmic blobs and a connecting strand of protoplasm) were united in preparation. This is answered by the fact that a plasmodium, the form of which, without grafting, has been so changed that there are two protoplasmic bodies connected by a single strand, also shows characteristics in its dynamoplasmogram which are identical to those of the grafted one.

In viewing the foregoing graphs, it is to be noted that the curves show no sign of a special deflexion when they cross the base lines; in other words, the points which correspond to the *moment of reversal* are not characterized at all by the shape of the curve. Previous investigators have almost implicitly adopted the moment of reversal of flow as the only criterion for distinguishing one rhythm from another; for other than this, there has been no gauge with which to

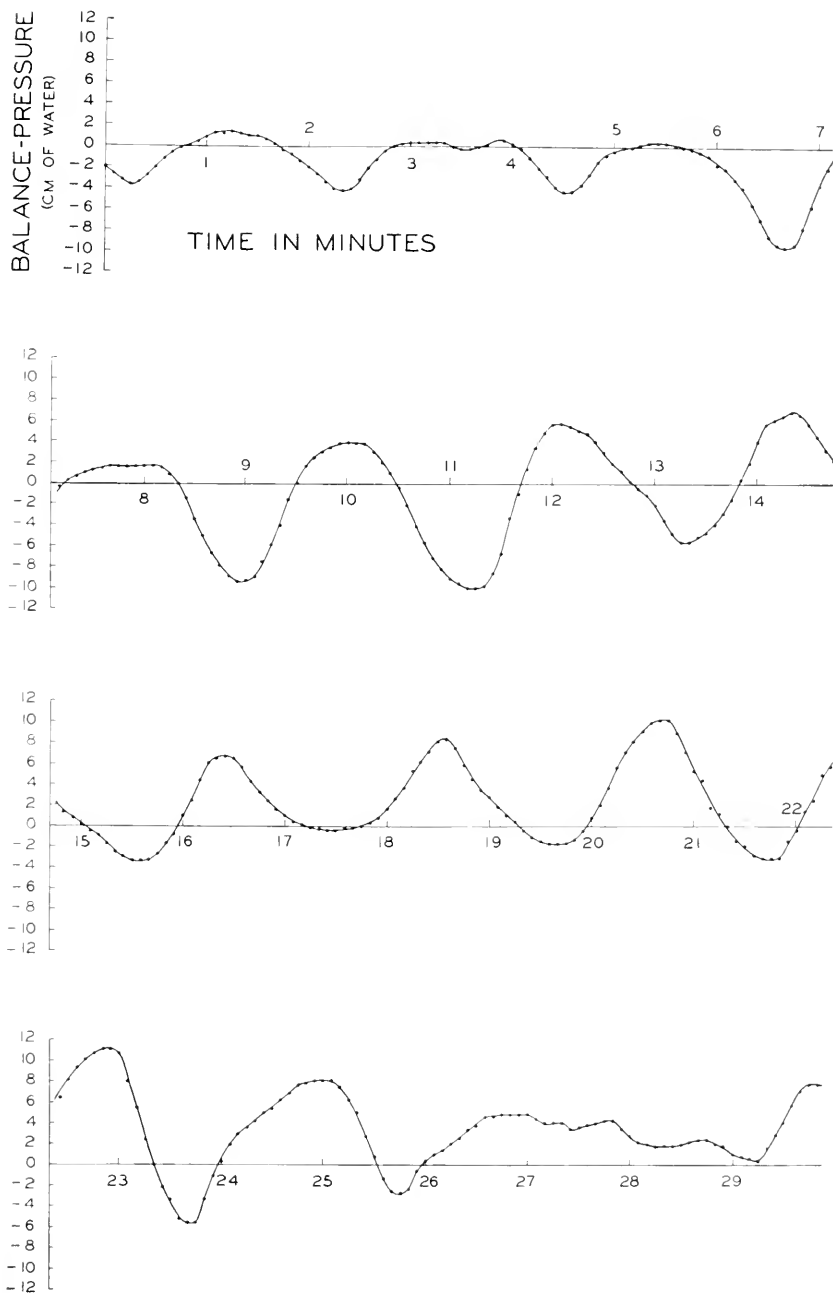

FIG. 9.

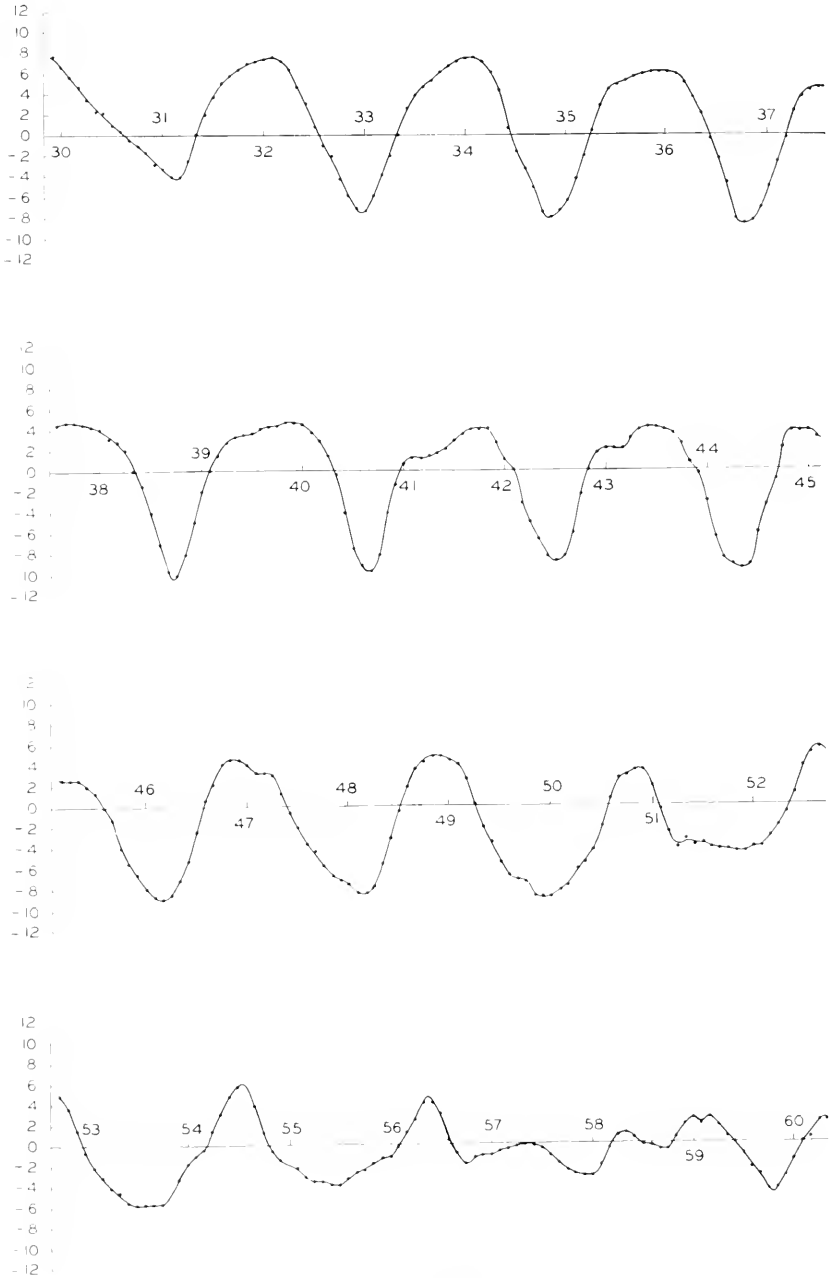

FIG. 9—continued.

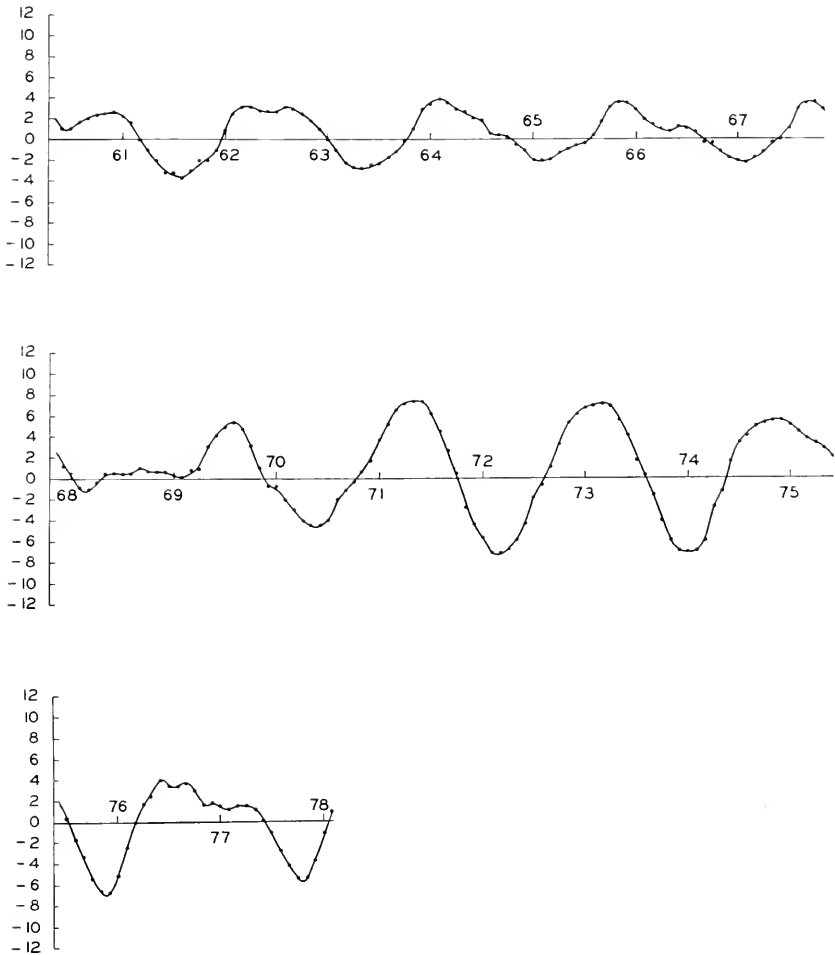

FIG. 9—continued.

measure the period of the rhythm. It is evident that this method of separating one rhythm from another is most practical, but one must keep aware of the fact that the instants of reversal, where the motive force is zero, have neither a significant meaning in rhythmic activity, nor do they imply the *same phase* of rhythm as manifested by the graphs (all except Fig. 10). A reversal moment simply means a momentary equilibrium of the intraplasmic forces. Pease (1940) is also of the opinion that cessation of flow indicates a temporary equilibrium state by acting as a "trigger mechanism."

Those who have once observed protoplasmic streaming in a plasmodium will recall the "abnormal", but not unusual, phenomenon that the protoplasm shows when it continues to flow only in one direction for an excessively long period of time. From such "abnormal" flow, one would necessarily be led to believe that protoplasmic rhythm is often "disturbed." If one bases one's judgment of the

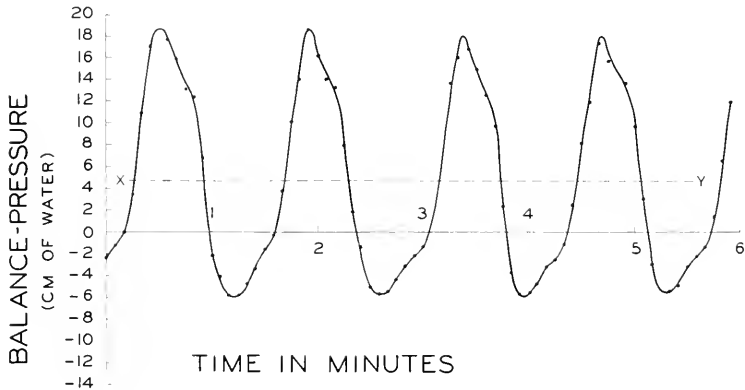

FIG. 10.

rhythm of protoplasm merely upon the reversal of flowing direction, then one will overlook the following important situation.

Figure 13 shows a case in which the whole undulating curve is on the + side of the zero-ordinate for about 12 minutes. This means that the motive force is exerted always in the same direction during this time (from *a* to *b*, Fig. 5). But nevertheless, the undulating curve strikingly reveals a regular change in the force generated in the protoplasm throughout that time.

Although Figure 13 represents an extreme case, it is generally noticeable in all the foregoing graphs that the area included within the curve and the zero-ordinate on the + side differs from that on the - side. This difference between the + and - side indicates that the motive force is not exerted equally in both directions, but always more in one direction than in the other. Because of this polar nature of the motive force, a plasmodium, were it free to move, would advance by flowing forward a little more each time and not retreating all the way back to its original position when it reverses.

Let us suppose a smooth line cuts an undulating curve in such a way that the area on the upper side of the line is equal to that on

the lower side. If the curve is periodic, or almost periodic, as in Figure 10, this line can be found easily with the aid of a planimeter, or by any other practical method. When the wave form changes from rhythm to rhythm, as is the case in many of the wave trains with which we are concerned, the line of which we speak is mathematically indeterminate. But in practice we can find such a line with

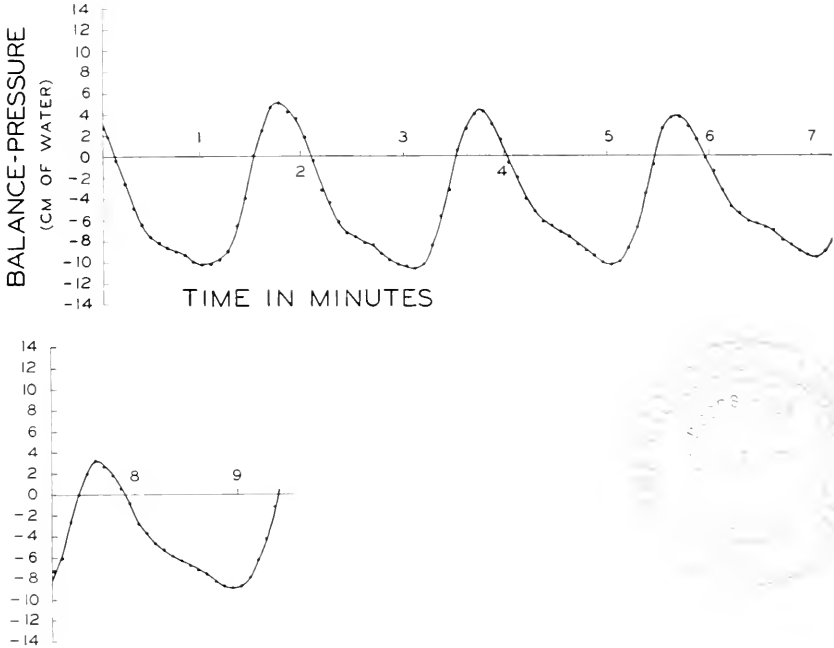

FIG. 11.

a certain degree of approximation. This can be done graphically by measuring the successive areas included within common tangents of consecutive crests or troughs, and the experimental curve. These areas divided by the distances between two contact points of the common tangents show the mean distances from the tangents to the line being sought.

The dash-dot lines XY in Figures 10, 12, and 13 are lines which divide the waves approximately into equal + and - parts. These lines show the "true" axes of the waves, the ordinate of which is a measure of the *polarity* of the plasmodium in its absolute scale. These true axes or "polarity lines," are generally (except Fig. 10) not parallel to the base line. Lack of parallelism shows that the

polarity, for which the displacement of the whole plasmodium is responsible, changes its intensity spontaneously. It may tentatively be assumed that polarity and rhythm are independent variables. This is a permissible assumption until the concrete meanings of polarity and rhythm are elucidated on a physical or chemical basis.

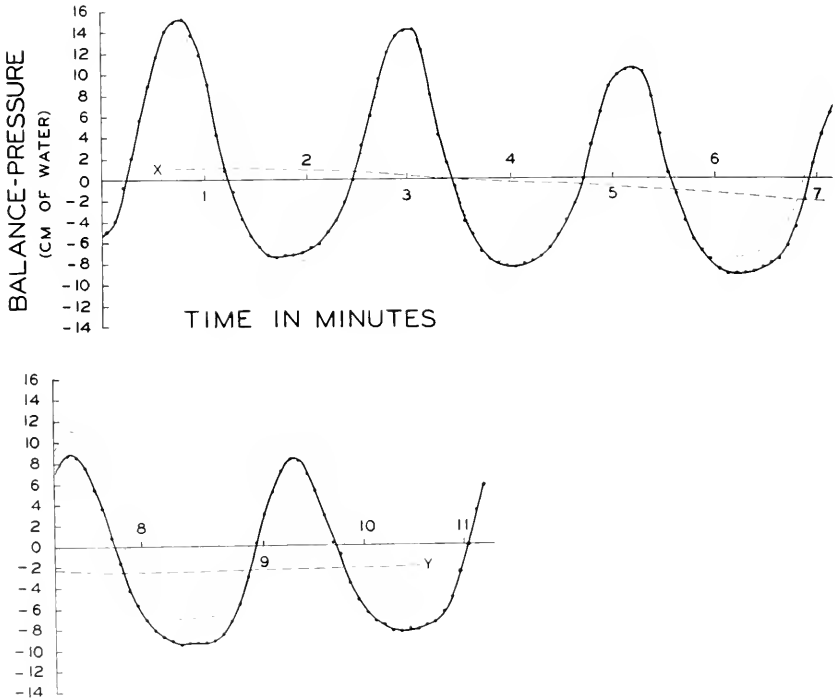

FIG. 12.

Although the true axes, or polarity-lines, are not shown in the above figures, except in Figures 10, 12, and 13, nevertheless, it is possible to find them in all cases with a limited degree of accuracy.

VIII. CHARACTER OF PROTOPLASMIC RHYTHM

We are now confronted with the fundamental problem of the character of the rhythm operated in the protoplasmic system. If the spontaneous increase and decrease in amplitude of the waves under the same external conditions are regarded as due to a physiological disturbance or to "fatigue" of the protoplasm, the question naturally arises, just what is the physiological disturbance; what is fatigue of protoplasm. A further question is the cause of the repeated

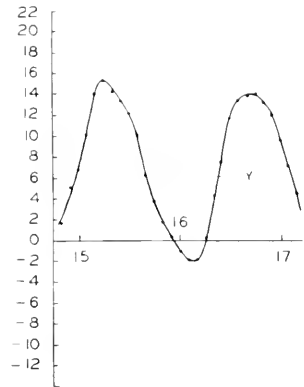
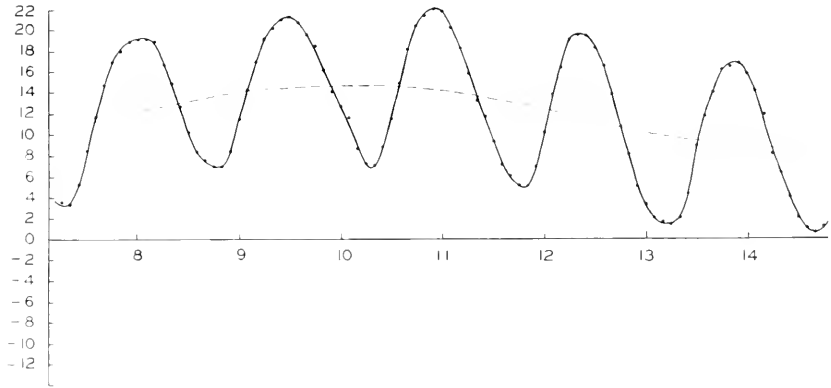
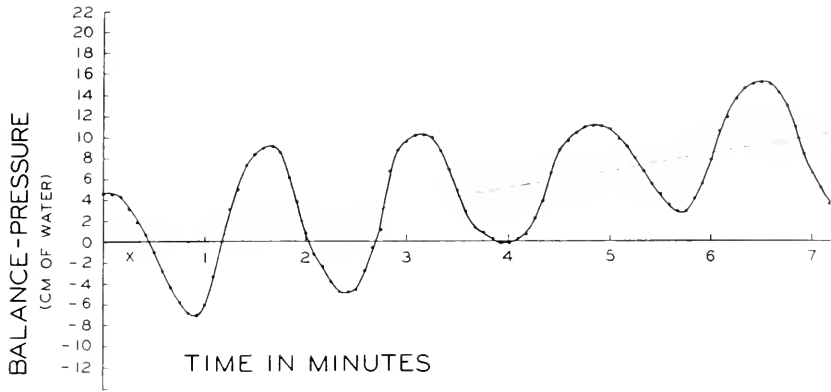

FIG. 13.

appearance of a characteristic wave form in successive rhythms (cf. Figs. 10, 11, and 12) of the vital process.

By studying many examples of wave trains, it seems most probable to me that such extraordinary variability in the pattern is due to nothing but the well-known physical phenomenon called *interference*.

Interference is one of the most remarkable phenomena associated with wave motion. It is well known in acoustics, optics, and other fields of science. The significance of interference in vital functions has, however, been scarcely considered. In order to study the rhythmic character of protoplasmic force, the rhythms being regarded as a combination of a series of components, it is pertinent to take up the general features of compounded harmonic waves.

A simple case is that of two superimposed harmonic waves having equal wave lengths. The resultant wave is a harmonic curve of the same frequency, no matter what the amplitudes and phases of the component waves may be. The amplitude of the resultant depends upon the amplitudes of the two component waves, and upon the phase difference between them. If the components are always in the same phase, the amplitude of the resultant wave is the sum of the amplitudes of the components. If one of the two components is half a period behind the other, the amplitude of the resultant is the difference of the amplitude of the components. From this, it follows that any number of harmonic curves of the same wave length may be so formulated that the resultant is a single harmonic curve of the original wave length. Conversely, if a harmonic curve is experimentally obtained, it can be assumed to be the resultant of numerous indeterminate harmonic components having the same wave length. The resultant wave will exhibit a harmonic curve regardless of the amplitudes and phases of the components. If, therefore, the pattern of a dynamoplasmogram shows pronounced similarity to a simple harmonic wave, this does not necessarily mean synchronous cooperation of the intraplasmic forces; it means simply, that all the component forces in one and the same plasmodium have the *same frequency* of the motor mechanism.

The next case is very important for our subject; it is that in which the frequencies of the two component waves differ slightly. Because of a difference in wave length, the phase difference between the two components does not remain constant. The amplitude of the resultant wave is increased when the waves are in the same phase, but when the waves are in opposite phases, the amplitude of the

resultant is reduced. Consequently, the resultant wave undergoes pronounced variations in amplitude. In the former case the resultant is "constructive", whereas, in the latter case it is "destructive".

When two simple tones, the frequencies of which differ slightly, are sounded together, a throbbing is heard. The two notes are said to produce "beats." This is a fact well-known to acoustics, and is represented in Figure 14 where the thin lines show two component waves, the ratio of the frequencies of which is 8:9. The resultant of these two component vibrations is shown by a thick line. The amplitude increases, when crest meets crest and trough meets trough, whereas, it decreases when crest meets trough. The number of beats per unit time is equal to the difference in the frequencies of the components during the same unit time. Therefore, the longer the period of one beat, the less the *difference* between the frequencies of the two components.

Although the component harmonic curves of different wave lengths can no longer be compounded into a single harmonic curve, as shown on the graph in Figure 14, the resultant is, nevertheless, periodic, if the wave length of the components are commensurable. If, on the other hand, the wave lengths are incommensurable, the period of the resultant curve is infinite, i. e., the resultant is non-periodic.

It is extremely interesting to compare the above-mentioned resultant wave with the experimental curve of the motive force generated in protoplasm. The alternation of waxing and waning periods bears a strong resemblance to the phenomenon of beats. In fact, increase and decrease in the amplitude of the dynamoplasmogram (Figs. 7 and 8) are, in all probability, due to the interference of intraplasmic forces, the rhythmic frequencies of which are slightly different from each other. At the waxing periods, two main component rhythms of the motive force reenforce each other, whereas, at the waning periods these two main groups oppose each other. In Figure 7, there are about eight waves in each "beat" of the dynamoplasmogram. Since one of the waves must gain a wave length on the other for each beat produced, one can say that the period of one of the two main components must differ about $\frac{1}{8}$ from that of the other. As one "beat" continues here for about 11 minutes, it is possible to evaluate the approximate difference in the period between the two components for about 10 seconds. In the case of Figure 8, the period ratio between the two main components will be ca. 3:4.

But the explanations above-mentioned are not quite enough.

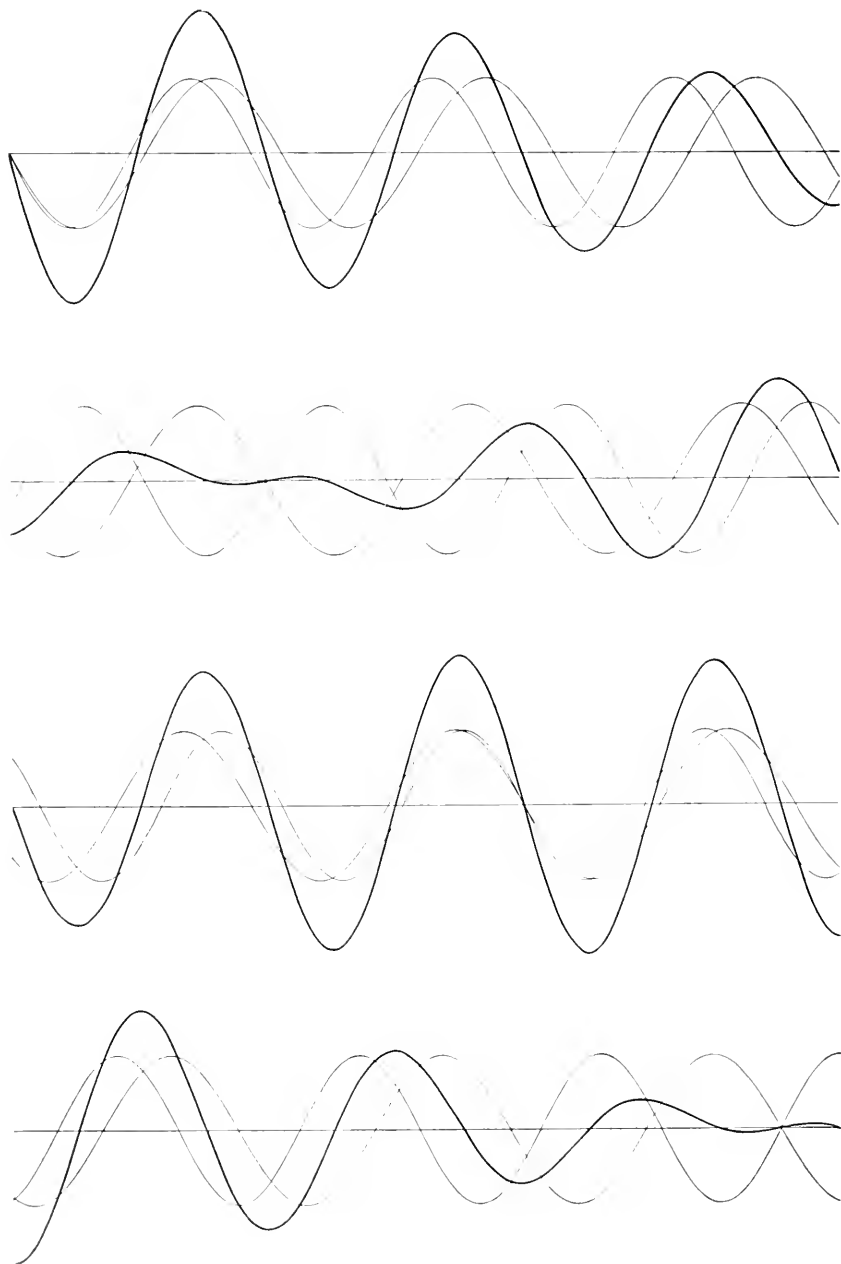

FIG. 14

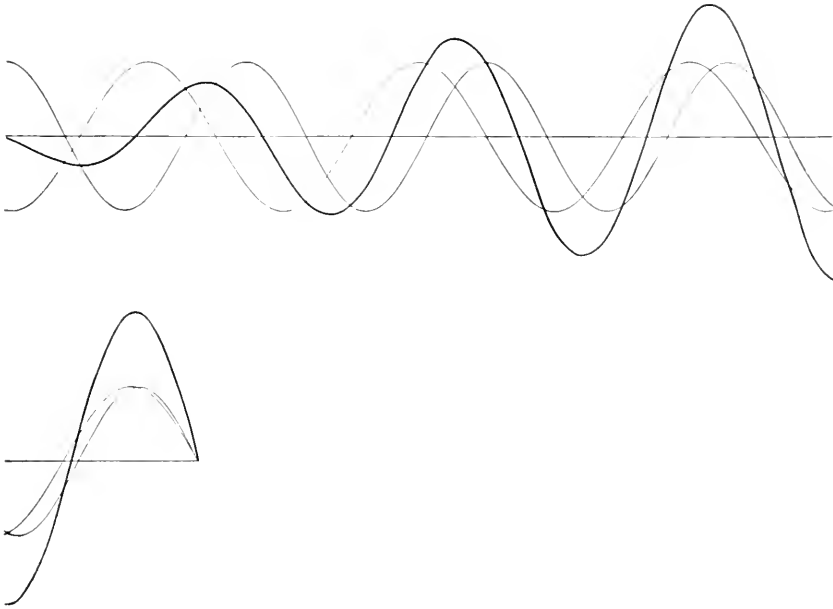

FIG. 14—continued.

Indeed, the interference of two component waves having slightly different frequencies is, in all probability, responsible for the major change in amplitude, but it can not be the general principle governing the protoplasmic system. In order to explain the repeated appearance of a peculiar wave form throughout several successive rhythms, the example of which is shown in Figures 10, 11, and 12, many subordinate components of different frequencies must be attributed to the protoplasm.

On the basis of the mathematical principle known as Fourier's Theorem, any one-valued periodic curve can be analyzed into harmonic curves of suitable amplitudes and phases having wave lengths of 1, $1/2$, $1/3$, $1/4$, $1/5$, and successive aliquot parts of the wave length of the wave to be analyzed. A given wave can be resolved into only one combination of simple harmonic curves of definite amplitude and phases. Theoretically, an infinite number of components is generally required to represent arbitrary periodic curves, but, for practical purposes, the first few components are sufficient, since the Fourier series converges rapidly for most wave forms.

The curve shown in Figure 10 is practically periodic within the

limit of the time scheme under consideration. Therefore, this curve can be analyzed into its Fourier components. The characteristic wave form of this figure enables one to predict that both odd and even harmonics are present. Figure 15 shows the analysis of the experimental curve of Figure 10 into its first four components. This analysis was done by means of a graphical method developed by Wedmore (1895). The amplitudes of the 1st, 2nd, 3rd, and 4th component, having the period of ca. 84, 42, 28, and 21 seconds are respectively 11.75, 1.95, 1.45, and 0.70 cm. of water. When these four

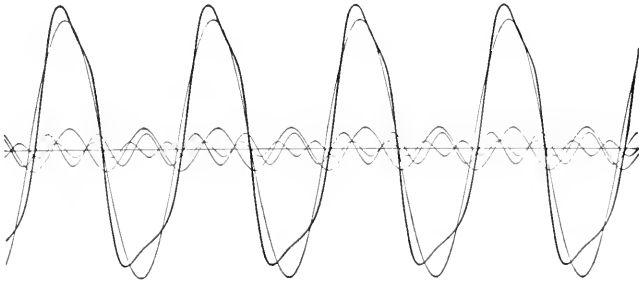

FIG. 15.

components combine, they produce the resultant shown in the thick line, which is almost the same as the dynamoplasmogram pattern of Figure 10.

In Figures 11 and 12, very similar wave forms are repeated, but the amplitudes do not remain constant during the experiments. These curves are non-periodic within the range under consideration. Although there is no general method of analysis for non-periodic curves, "much information may be obtained from such curves by making skillfully assumed analyses" (Miller, 1916, 141). The gradual decrease of amplitude is assumed to be due to an interference effect between two components, the frequencies of which are nearly in unison; it is not due to the gradual "exhaustion" of the protoplasm. The amplitude will increase again after a certain period of time.

By varying the amplitudes and wave lengths of the components and shifting them arbitrarily along the axis, very similar resultant waves can be reproduced from three components. Figure 16 shows the redrafting of Figure 11. The resemblance of both the experimental curve (Fig. 11) and the resultant of the artificially combined harmonic curves (Fig. 16) is striking. The serial ratio of the wave

lengths of the three components is 90:87:44; that is, two of the three components have only slightly different wave lengths, whereas, the other component has a wave length but half as long as the other two. This component of short wave length is responsible for the peculiar asymmetric pattern of the curve.

Figure 17, showing the resultant of three harmonic components, resembles the experimental curve in Figure 12. The acute crests and flat troughs result from a component whose wave length is half of one of the other components, the wave lengths of which are

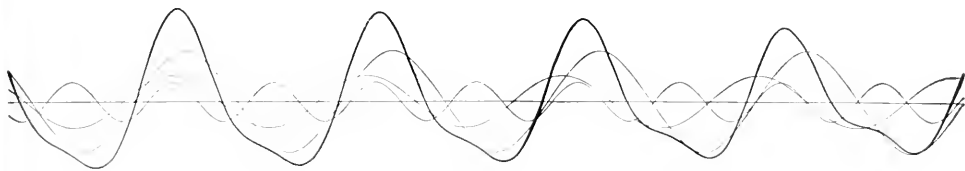

FIG. 16.

slightly different from each other. The three components of different wave length are in the ratio 18:17:9. In this case the disturbing effect of polarity must be considered. The strength and direction of polarity change during an experiment, as shown in Figure 12, where the true axis (dash-dot line) is not parallel to the base line and crosses it, revealing a reversal of polarity. If one subtracts the ordinates of the true axis, or polarity line, from the ordinates of the curve, and plots these from the same base line, a new curve (dotted) results, which represents the rhythm from which the polarity effect is eliminated. The pattern of the "pure" rhythm (dotted), after the elimination of the polarity effect, bears a strong resemblance to that in Figure 17.

It has been shown in the above figures that the series of components of Figures 15, 16, and 17 give resultants which are very similar to the protoplasmic rhythm experimentally determined. These components postulated for the protoplasmic rhythm are presumed not to be purely abstract ones, but to have a real meaning, each functioning separately as a physical entity in the vital system. The motive force measured is regarded as an *actual resultant of intraplasmic interference* of various simple harmonic component forces and, in part, of polarity. This concept necessarily implies the co-existence of different frequencies and amplitudes in the motor mechanism of one and the same plasmodium. Dynamoplasmogram

patterns may all be different, but the essential nature of the protoplasmic rhythm must be the same in all. The basic character of the protoplasmic rhythm is also a simple harmonic function of time. But the protoplasm is not driven by a single rhythm; it is driven by a complexity of rhythms; in short, a plasmodium is *polyrhythmic*.

IX. DYNAMICAL ASPECTS OF INTRAPLASMIC CONDITIONS

It has been stated in the foregoing section, that the motive force responsible for protoplasmic streaming is operated, not by a single

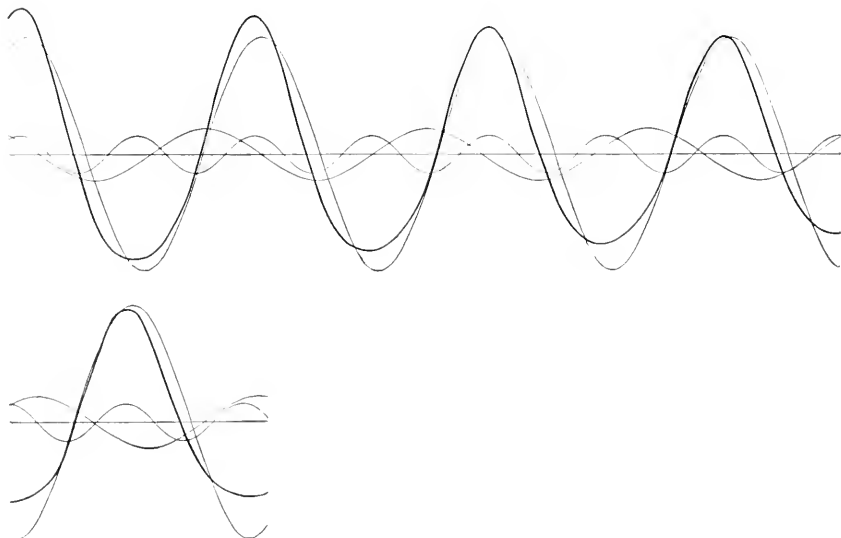

FIG. 17.

rhythm, but by a complexity of rhythms having unequal frequencies and magnitudes. It must be noted, however, that the combination of the components, which represent a definite portion of the dynamoplasmogram, may not represent other portions beyond the limit of time scheme under consideration. Lack of accuracy of the analysis is one reason for this. No general method of analysis is applicable to the curves with which we are mostly concerned. But even if one could analyze a limited portion of a dynamoplasmogram into an exact series of components, the combination of the same components would not represent the same dynamoplasmogram unlimitedly.

An important reason why the components postulated for one portion of the curve can not represent other portions seems to be the instability of the components. This means that the components themselves are not kept constant during an experiment; in other words, a dynamoplasmogram contains *variable* components. Even when the extrinsic factors are kept constant, the intrinsic factors of the protoplasm change spontaneously. For instance, as the protoplasm spreads during an experiment, the surface-volume ratio of the plasmodium may change; this will affect intraplasmic diffusion involved in many physiological processes, especially in respiration. Change in intraplasmic diffusion is but one of the factors which possibly alter the components of the rhythmic motive force and so restrict the analysis to that portion of the curve which represents the period of an experiment.

Spontaneous change in polarity, no matter what the real physico-chemical meaning of polarity may be, also disturbs the dynamoplasmogram pattern. Polarity factors are also in part responsible for the fact that components postulated for one portion of a dynamoplasmogram can not represent other portions of the same dynamoplasmogram beyond the limit of the time scheme. The meaning of polarity, physically or chemically considered, is not clear, but it may be considered as an entity apart from rhythm. Watanabe, Kodati, and Kinoshita (1937) found that the anterior portion, in the direction toward which the plasmodium advances as a whole, has always a higher electric potential than the posterior part, although potential difference between the anterior and posterior parts show a close correlation with the rhythmic reversal of flow. It is probable that the potential difference is, in some way, connected with the polar nature of the motive force, if it is not the direct cause of the polarity of the motive force.

To sum up, it is obvious that the rhythm of the motive force is modified, to a greater or lesser extent, by internal factors under constant external conditions.

The waves shown in Figure 9 change their amplitude and form, but the periods of increased and decreased amplitude continue for an irregular duration of time. There is no regularity, either in regard to the wave form or to the change in amplitude. Nevertheless, the basic rhythm must operate according to a regular rhythmic pattern. Such a curve is regarded as containing many subordinate components, the frequencies of which are not in simple ratios to one

another. Furthermore, all components do not necessarily remain constant in frequency and amplitude, but can change spontaneously.

In Figure 7 the waxing and waning periods of the curve are repeated without the details of the waves. The envelope, or imaginary margin of the curve, is not periodic. Such is also the case in Figure 8. If there are only two constant component waves, whose periods differ slightly from each other, the envelope of the resultant wave is periodic, no matter whether the frequencies of the two components are commensurable or not. Furthermore, the resultant waves at the waning periods do not exhibit such irregular and ragged pattern as revealed by the curves shown in Figures 7 and 8.

It is probably true that the major change in amplitude is due to the same principle as that of beats, as stated in section VIII. But actually, there must exist more subordinate components which would explain the irregular pattern of the waning periods insofar as they diverge from the regular beat wave pattern. The wave patterns of Figure 7 are, therefore, a compound rhythm consisting of two main components having slightly different frequencies and many subordinate components of small wave lengths. All these components may be variable to a certain extent. The situation in Figure 8 is also similar to that of Figure 7.

The general situation of the intraplasmic force is really not simple. It is a necessary conclusion of the analytical study of the dynamoplasmogram that there must exist components having not only slightly different frequencies, but also very divergent ones, namely, frequencies twice, three times, and perhaps, even larger than that of the lowest (fundamental) frequency. The course of reasoning is rather abstract, yet without the concept of polyrhythm, it will be impossible to explain the various types of dynamoplasmogram patterns. As stated in this section, the components are unstable; they may not remain constant during a period of time. But the components, even though they are variable, must have an identity of their own. One and the same plasmodium must produce many frequencies of rhythm simultaneously.

The next important question with which we are confronted is naturally the origin of the different components. The concept of polyrhythm must be harmonized with the actual mechanism and structure of protoplasm.

Mechanical engineers often study the vibration of machines by separating it into a series of components by analytical methods. Since each part of a machine has its own frequency of vibration, the

analytical method is a very helpful means of learning from what part of the machine the vibrations come.

In the case of protoplasm, we do not know in what parts of the plasmodium the components having different frequencies originate. Each component postulated for the motive force represents simply the resultant of a group of waves having that frequency of different amplitudes and phases generated in any locus of the plasmodium. Components having different frequencies may come from different loci of one and the same plasmodium. It is, however, surprising that components having not only slightly different frequencies, but very divergent ones are operative in the same protoplasmic system.

A single string, when it vibrates, produces a series of "over-tones" simultaneously, the frequencies of which are $2\times$, $3\times$, $4\times$, and successive aliquot parts of the fundamental vibration. Whether divergent frequencies of components of the protoplasmic force have structurally or physiologically a common origin, just as in the case of a series of overtones from the vibration of one and the same string, or whether divergency of rhythm is attributable to structural heterogeneity of the protoplasm, is a problem for the future.

X. ANALOGY AS A MEANS OF ILLUSTRATION

An attempt to compare a complex mechanism, such as a plasmodium, which is composed of many unknown factors, with a simplified model may seem to be misleading. Nevertheless, an illustration by means of a model will be helpful, insofar as it is concerned with an explanation of the physical principle which governs the complex living system, just as it governs the simple non-living model.

The first problem in construction for this analogy is to make a model which, in gross form, resembles the plasmodium with its two parts connected by a single strand of protoplasm. Figure 18 shows a double chamber containing two water reservoirs connected by a single tube. These two reservoirs are comparable to the two blobs of protoplasm in the double chamber (cf. Fig. 5). The bottom of each of these two reservoirs can be moved up and down by means of a pin-and-slot device. As there is a difference h between the two water levels in reservoir a and b , the water has a tendency to flow from a through the tube to b . The motive force of the movement of the water through this connecting tube is expressed in terms of the *difference* in pressure (difference h in level) between the two reservoirs, and not the *absolute* pressure H at the height of the

connecting tube. In order to prevent a flow from *a* to *b*, additional air-pressure must be applied to compartment *B*. This additional pressure is the same as the pressure difference corresponding to the level difference *h* between the two reservoirs. Like this model, the

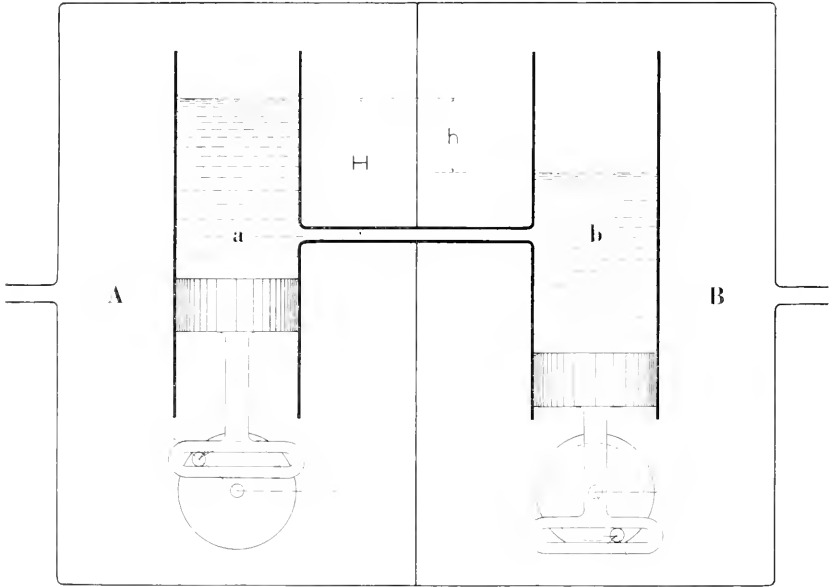

FIG. 18.

balance-pressure of protoplasm is not concerned with the absolute inner pressure of a plasmodium, but with the difference in pressure between the two parts.

When water in the connecting tube of the model is kept motionless, because it is opposed by a balance-pressure, the pressure along the horizontal tube is the same as the hydrostatic pressure corresponding to the height of the water level of reservoir *a* above the tube (*H* in Fig. 18). When, however, the balance-pressure is released and water begins to flow, the inner pressure of the tube varies in accordance with its horizontal position between *a* and *b*. The farther the position of the tube is from reservoir *a*, the lower is the inner pressure. This is true because the potential energy, represented by the difference in level, must in part be expended in giving velocity to the water (velocity head) and also, in overcoming the viscosity (resistance head). This is a well-known fact in hydraulics, and must also in part be true in the protoplasmic system.

Using the same model, the case will now be considered in which the two cranks are turned slowly with the same angular velocity (change in pressure due to positive and negative acceleration of water is neglected), and the air-pressure in compartment *B* is constantly adjusted so as to stop the movement of water in the connecting tube. Since there is no exchange of water between the two reservoirs under such circumstances, their levels show motion which is exactly the same as that of the pistons; this is simple harmonic motion. The combination, either addition or subtraction, of two simple harmonic motions having the same frequency gives rise to another simple harmonic motion of the same frequency. This being so, the balance-pressure which holds the water in the tube at a standstill and is equal to the pressure that is equivalent to the difference between the two levels, can be expressed by a simple harmonic function of time. This holds true, no matter what the phases and amplitudes are, provided the angular velocities of the two cranks remain the same.

The next case to be considered is that in which the two cranks have slightly different angular velocities. The motion of the pistons is of a simple harmonic nature, but each motion has different frequencies. At some point in the time scheme, the pulsation of the pistons will be in the same place, but the next moment the phase of the pulsation in one reservoir will have advanced beyond that of the other. After a certain period of time, periodic movement of the pistons in both *a* and *b* will attain phases which directly oppose each other.

If, when the two pistons pulsate with slightly different frequencies, one plots the change in balance-pressure of the model against time, there will result a curve which reveals a pattern with alternating periods of increase and decrease in amplitude exactly as in the case of beats (cf. Fig. 14). When the pulsation of the two pistons are in the opposite phases, the amplitude of the curve will reach its maximum (waxing period). When the two pulsating motions are in the same phase, the amplitude of the curve is at its minimum (waning period).

It is likely, though not necessarily so, that in one plasmodium, when its dynamoplasmogram reveals a wave pattern resembling beats (cf. Figs. 7 and 8), the rhythmic frequency of the protoplasm in one compartment is not the same as the frequency of that in the other, just as in the case of the two reservoirs, when each has a different pulsating frequency.

Early in this experimental work, the plasmodium was recognized as polyrhythmic. Each reservoir in the model shown in Figure 18 has only a single frequency of rhythm, whereas, the motive force generated in the protoplasm lying in one compartment will be of a number of different frequencies existing simultaneously. At this point, the analogy drawn between protoplasm and model ceases to hold. In order to make the analogy hold for the polyrhythmic fea-

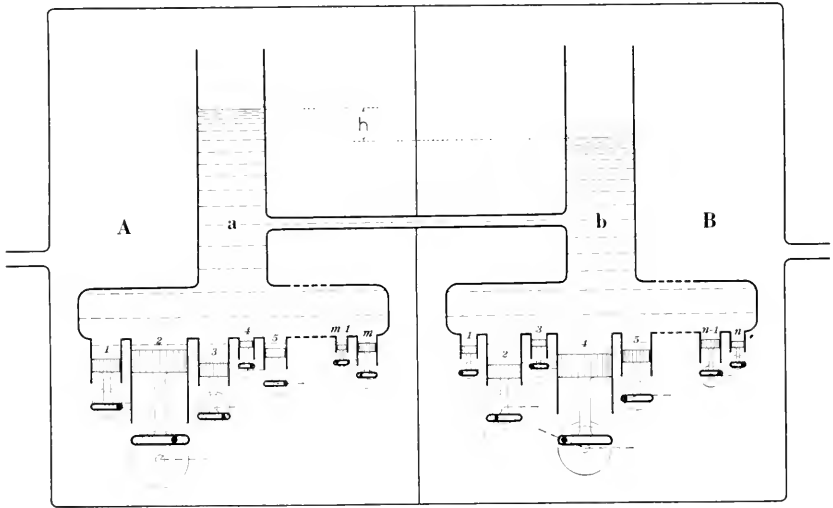

FIG. 19.

ture of a plasmodium, a second model must be constructed. Such a model is shown in Figure 19. Here we have a double chamber containing a two-reservoir system connected by a single tube like that in Figure 18, but here each reservoir has an arbitrary number of pulsating pistons of various sizes.

Let us suppose that a balance-pressure is applied to compartment B, so as to keep the water in the connecting tube at a standstill. When all the cranks of these pistons rotate slowly with the same angular velocity, the levels of the two reservoirs undergo simple harmonic motion, since any number of simple harmonic motions of the same frequency is always combined, regardless of amplitudes and phases, into one simple harmonic motion of the same frequency. If, however, some of the cranks turn with different angular velocities, the two levels no longer show simple harmonic motion. The difference, h , between the two levels to which the pulsation of each small

piston with its individual frequency makes its own contribution, is not a simple harmonic function of time. The balance-pressure under such conditions, when plotted against time, will produce wave patterns similar to those revealed by dynamoplasmograms. The wave patterns depend upon pulsating frequencies and phases of these individual pistons, and also upon the capacity of a stroke of each piston which represents the amplitude of that component.

It is self-evident that in a plasmodium the mechanism responsible for protoplasmic flow has nothing to do with a pulsating mechanism of pistons. The above models are presented as possible imaginary machines which will produce, when suitably operated, a wave pattern of the balance-pressure similar to that of the dynamoplasmogram. For simplicity's sake, the factor of polarity, which is involved to a greater or lesser extent in a plasmodium, is not taken account of in these models. But the concept of *intraplasmic interference* of component rhythms will be understood by such simple models. Only as to the rhythmic character of the motive force are slime mold protoplasm and the models illustrated in the above figures comparable.

XI. REACTION OF PROTOPLASM AS REVEALED BY THE DYNAMOPLASMOGRAM

The experimental data obtained from the present investigation are all concerned with normal protoplasm. The results of the experiments show that the dynamoplasmograms are of divergent patterns and change from time to time in the same plasmodium under the same external conditions.

Despite variability in the pattern of the normal dynamoplasmogram, it reveals much about the physiological conditions of pathological protoplasm. Plasmodia treated with certain artificial agents, such as anesthetics—this can be done by using a special double chamber having four taps—show very peculiar dynamoplasmogram patterns. Change in amplitude, wave length and wave form is often characteristic of the treatment. Just as the heart specialist can learn from the pattern of electrocardiograms more about the heart and circulatory system than he can determine by any other method of diagnosis, so the protoplasmologist will learn more about the protoplasmic mechanism from pathological patterns of dynamoplasmograms than he can determine by microscopic observation. A better understanding of the general characteristics of protoplasmic reactions is to be had from a comparative study of dynamoplasmograms.

Especially helpful in an analysis of the effect of an external agent on protoplasmic reactions is a study of two dynamoplasmograms, one obtained from a plasmodium which had been treated in entirety by an external agent, and the other obtained from a plasmodium of which only one-half was subjected to the same agent. The latter condition is easily accomplished by using the double chamber, the external agent being applied only to one compartment and therefore, only to one-half of the plasmodium. As a result, the plasmodium undergoes a modification in polarity. The dynamoplasmograms plotted from this, show that very often the whole wave is shifted to one side of the base line without crossing it, but the rhythm continues.

Phenomena known as taxis, such as chemotaxis, phototaxis, thermotaxis, rheotaxis, galvanotaxis, etc., have been studied in slime molds by many research workers since the last century. All taxic movements, no matter what kind they may be, result from the polar nature of the motive force. A change in polarity due to unequal distribution of external factors can be very exactly portrayed on the dynamoplasmogram on the quantitative basis. The *half-treatment-dynamoplasmogram* offers interesting problems when studied in comparison to the *whole-treatment-dynamoplasmogram*.

XII. RHYTHMICITY AS AN ATTRIBUTE OF PROTOPLASMIC ACTIVITY

It was stated that the rhythmic motive force does not disappear even though the movement is arrested for a period of time. From this fact one can assume that the displacement of protoplasm by streaming can play no part in the causal chain of the mechanism of reversal. Rhythmic mechanism has, therefore, nothing to do with the relation of action and reaction brought about by the flowing of protoplasm. Thus, the views which postulate that a possible physical or chemical change accompanying the change in distribution of protoplasm is the cause of the reversal may be discarded in the light of the above findings. Rhythm is a more deep-seated attribute of protoplasm.

The rhythmic activity of protoplasm discussed in the present paper is concerned only with slime molds. It is, however, a question, and an important one, whether or not polyrhythmic nature is the specific attribute of slime-mold protoplasm or whether it is essentially universal and, therefore, occurs in other protoplasmic systems. The fact that a visible form of movement does not show periodicity can not offer any cogency to the argument that the basic motor mechan-

ism is not rhythmic. If the rhythmic activity of each structural unit be of a random nature both in regard to the phase and direction, periodicity in the total mass will statistically tend to be canceled out. Rhythm will be observable only when each unit cooperates or synchronizes to a certain degree.

Some Euglenae, e. g. *E. deses*, exhibit a characteristic change in shape and attendant streaming of the endoplasm, which is generally known as "euglenoid movement" or "Metabolie." This is a sort of amoeboid movement in the sense that the streaming of protoplasm involves a change in shape. Under normal conditions the movement is quite irregular and with no indication of rhythm. It is, however, very interesting to point out that when some Euglenae are transferred into acid solutions or subjected to other unfavorable conditions, the movement soon begins to show almost perfect periodicity for a considerable time before death takes place (Kamiya, 1939). The rhythm is in this case pathological, yet nevertheless, it does show that a periodic mechanism is inherent in an organism which does not exhibit any periodic movement whatever under normal conditions.

In order to explain the streaming movements of protoplasm, known as rotation and circulation, which observably are not rhythmic, it may be necessary, regardless of the nature of motive forces, to postulate a rhythmic cycle in the motor mechanism. Indeed, rhythmic mechanism may exist in protoplasmic function, but is concealed behind the non-rhythmic resultant. There is no reason to believe that the mechanism responsible for other forms of rhythm, such as ciliary movement, is essentially different from that responsible for protoplasmic streaming. It is, however, a problem left for the future, how far rhythmic mechanism is a universal attribute of living matter.

It is true that the energy used for protoplasmic streaming is furnished ultimately by respiration. But the rhythmic output of mechanical energy (motive force) does not necessarily imply a rhythmic pattern in respiratory function. A periodic mechanism may be ascribed to any definite part in the total chain of intraplasmic reactions.

According to the view advanced by Professor Seifriz (1937, 1938), streaming in slime molds is caused by a "rhythmic contractility" of the protoplasm, due probably to the shortening of protein fibers by molecular folding or, possibly, helical contraction. Although it is not within the scope of the present paper to indulge in specu-

lation on the concrete meaning of the polyrhythmic functioning of protoplasm on a physical or chemical basis, it may be added that the difference in frequency of component rhythms may mean a difference in frequency of the contracting and relaxing rhythm of protoplasm.

I wish to express to Professor William Seifríz my sincere appreciation of his kindness in extending to me the courtesies of his laboratory. I was encouraged by his constant aid and cooperation during the course of these experiments. I am indebted to Professor Jacob R. Schramm for permission to work in the Botanical Laboratory of the University of Pennsylvania. Finally, it is my most pleasant duty to acknowledge with thanks the aid granted me by Mrs. Curtin Winsor, who graciously made it possible for me to carry out the present work by supporting my research.

LITERATURE CITED

- BALBACH, H. 1936. Über Plasmadifferenzierungen in Plasmodien der Schleimpilze. *Protoplasma* 26:161-180.
- CAMP, W. G. 1936. A method of cultivating myxomycete plasmodia. *Bul. Torrey Bot. Club* 63:205-210.
- . 1937. The structure and activities of myxomycete plasmodia. *Bul. Torrey Bot. Club* 64:307-335.
- EWART, A. J. 1903. On the physics and physiology of protoplasmic streaming in plants. Oxford.
- HEILBRUNN, L. V. 1937. An outline of general physiology. Philadelphia.
- HILTON, A. E. 1908. On the cause of reversing currents in the plasmodia of Mycetozoa. *Jour. Quekett Micr. Club* 10:263-270.
- KAMIYA, N. 1939. Die Rhythmik des metabolischen Formwechsels der Euglenen. *Ber. d. Deutsch. Bot. Ges.* 57:231-240.
- . 1940. Control of protoplasmic streaming. *Science* 92:462-463.
- MILLER, D. C. 1916. The science of musical sounds. New York.
- PEASE, D. C. 1940. Hydrostatic pressure effects upon protoplasmic streaming in plasmodium. *Jour. Cell. and Comp. Physiol.* 16:361-369.
- PFEIFFER, H. 1936. Further tests of the elasticity of protoplasm. *Physics* 7:302-305.
- . 1937. Experimental researches on the non-Newtonian nature of protoplasm. *Cytologia Fujii jub. vol.* 701-710.
- SEIFRIZ, W. 1937. A theory of protoplasmic streaming. *Science* 86:397-398.
- . 1938. Recent contributions to the theory of protoplasmic structure. *Science* 88:21-25.
- VOUK, V. 1910. Untersuchungen über die Bewegungen der Plasmodien. I. Teil. Die Rhythmik der Protoplasmaströmung. *Sitzungsber. d. kais. Akad. d. Wissensch. Wien, math.-naturwiss. Kl.* 119:853-876.
- . 1913. Untersuchungen über die Bewegungen der Plasmodien. II. Teil. Studien über die Protoplasmaströmung. *Denkschr. d. kais. Akad. Wissensch. Wien, math.-naturwiss. Kl.* 88:653-692.
- WATANABE, A., KODATI, M., UND KINOSHITA, S. 1937. Über die Beziehung zwischen der Protoplasmaströmung und den elektrischen Potentialveränderungen bei Myxomyceten. *Bot. Mag. (Tokyo)* 51:337-349.
- WEDMORE, E. B. 1895. A graphical method of analyzing harmonic curves. *Electrician* 35:512-513.



SOME PHYSICAL PROPERTIES OF PROTOPLASM AND THEIR BEARING ON STRUCTURE

WILLIAM SEIFRIZ

The demonstrable physical properties of protoplasm indicate its hidden structure. In the introduction to this Monograph, I dealt with bonds between linear molecules. Neither the bonds nor the linear molecules which they tie together is visible, but their presence is required to satisfy the needs of a fluid and elastic system.

There are many qualities of living matter which owe their existence to specific structural features. One of these is thixotropic behavior.

THIXOTROPY

Professor Freundlich, in his contribution to this Monograph, has discussed thixotropy from a purely physical and chemical point of view. He would have added some biological applications had he lived to complete the chapter. I shall, therefore, do this for him, and then tell in more detail of one application to which I have of late devoted considerable attention.

Thixotropy, as originally described by Schalek and Szegvary¹, referred to the sudden collapse of a gel due to mechanical agitation. A simple example of this in living matter is the commonly observed liquefaction of protoplasm when disturbed by a needle. Mechanical agitation is, however, just as likely to produce solidification of protoplasm as liquefaction, for the most common characteristic of death is coagulation. I shall later suggest that both phenomena, when they occur suddenly, may be included under the term thixotropic behavior.

More closely resembling the original observation of Schalek and Szegvary is the complete and sudden collapse of one-celled organisms when severely punctured by a needle. Protozoa and the eggs of algae often disintegrate instantaneously on being quickly punctured with a needle; they literally blow up. Very striking also is the complete collapse of a dividing echinoderm egg in midmitosis

¹ Kolloid Zeitschr., 32, 318; 33, 326. 1923.

when subjected to pressure. No vestige of the structural features of the preceding karyokinetic figure remains.

Among his many previous references to physiological examples of thixotropy, Freundlich² cites an experiment by Fauré-Fremiet³, who found that mechanical agitation would change an Amoeba from the firm condition of its resting state to the fluid condition of its active state. Peterfi⁴ described the liquefaction of the gelled protoplasm of neuroblasts caused by the movement of a needle.

It is a pathological case of thixotropic behavior, involving not collapse but the rapid setting of protoplasm, of which I wish to speak in detail, and in so doing I should like to broaden the concept of thixotropy so as to include the instantaneous and spontaneous setting of a colloidal system. A truly thixotropic gel always undergoes rapid gelation after collapse. As both phenomena are characteristic of thixotropic behavior, there is no reason why emphasis should be laid upon one any more than upon the other, especially, since the instantaneous setting is as remarkable as the sudden collapse by agitation.

The thixotropic collapse of a gel due to agitation is a form of liquefaction which is characterized by the suddenness with which it takes place. Just so is the instantaneous setting of a colloidal system a form of gelation or gelatinization characterized by the rapidity with which it is accomplished. The occurrence of either of these phenomena in living matter may be spontaneous or the result of a pathological condition. As I shall refer primarily to thixotropic setting, it may be well to define it as the instantaneous and readily reversible gelatinization of protoplasm or other colloidal system.

Much of the protoplasm of slime molds is in a state of continuous flow. The movement is first in one direction and then in the other, reversal occurring every forty-five to fifty seconds. Any pronounced change in the rhythmical flow of the protoplasm is an indication of a change in physiological condition.

If subcultures of slime molds, in particular, *Physarum polycephalum*, are placed in a small gas chamber and subjected to certain anesthetic agents, the streaming protoplasm comes to a sudden stop. Recovery takes place within a minute or two, and there is no observable injury. Three anesthetics accomplish this perfectly: carbon dioxide, cyclopropane, and chloroform (Fig. 1).

² Chemisch Weekblad (Amsterdam), 32, 739. 1935.

³ Trans. Faraday Soc., 26, 779. 1930.

⁴ Arch. exp. Zellforsch., 4, 143. 1927.

The average time for the anesthesia of Myxomycetes by carbon dioxide, administered with an equal proportion of oxygen, is one minute, with recovery in the same time. A proportion of three parts carbon dioxide and one part oxygen produces anesthesia in half a minute, and permits recovery within two minutes. The time for both anesthesia and recovery varies with the concentration and

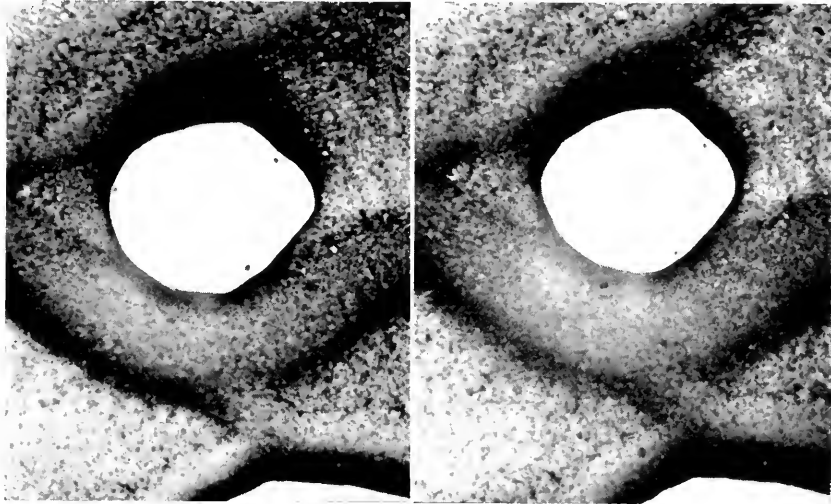

FIG. 1. A plasmodium anesthetized with carbon dioxide: left, the normal protoplasm at the moment of reversal in flow; right, the anesthetized protoplasm. In the latter the protoplasm is quiet and remains so for several minutes, followed by a return to normal; note absence of any injury or observable pathological change in the anesthetized protoplasm.

method of application of the gas. A substantial dose quickly given will put the plasmodium under within twenty seconds, and may delay recovery for from eight to ten minutes. As low a concentration as 10 per cent of carbon dioxide is sufficient to produce anesthesia for brief periods.

Of general biological and medical interest are the unexpected results that carbon dioxide proved to be the most successful anesthetic agent for Myxomycetes though that gas is one of the least satisfactory for man; that ether, the most used among surgical anesthetic agents, proved very unsatisfactory for slime molds; that cyclopropane and chloroform are as successful in inducing the anesthesia of very primitive forms of living matter as they are in anesthetizing higher forms of life; and that ethylene, one of the

newer and best anesthetics for man, had no observable effect whatever on slime molds.⁵ Ethylene not only failed to produce anesthesia in slime molds, but it stimulated their growth, an unexpected result which may be due to increased respiration.

That feature of the anesthesia of slime mold protoplasm by carbon dioxide, cyclopropane, and chloroform which is of chief interest to us at the moment is the instantaneous cessation of streaming. There is little warning, occasionally a momentary tremor, and then a sudden and complete stopping of flow. On removal of the anesthetic agent there is resumption of normal activity, with no observable damage.

It is only necessary to observe the sudden cessation of protoplasmic movement in a slime mold due to the application of a suitable anesthetic agent to be convinced that the protoplasm has undergone a pronounced change in its physical as well as its physiological state, yet no change is evident other than a stopping of flow.

The instantaneous cessation of protoplasmic streaming caused by carbon dioxide appeared to involve a setting or gelatinization of the protoplasm. It also seemed likely that the failure of other anesthetic agents to put a sudden stop to protoplasmic streaming was an indication that no gelation had taken place, but there was no direct proof of either deduction.

By means of an ingenious technique involving the application of pressure, Kamiya is able to oppose and control protoplasmic flow (pp. 205, 206). If protoplasm is quiet, due to anesthesia, pressure externally applied should cause it to move if it is in a liquid state, and fail to move it if it is firm. Such proved to be the case. Protoplasm under ether, which produces only partial anesthesia of slime molds, is readily moved by externally applied pressure, whereas protoplasm under carbon dioxide cannot be made to flow by pressure. Obviously then, under carbon dioxide the protoplasm is firm; under ether it is fluid.

The foregoing facts form the basis of a theory of anesthesia, applicable to those cases where suspended animation is brought about quickly, as with carbon dioxide, cyclopropane, and chloroform when applied to slime mold protoplasm. The theory states that anesthesia is due to the thixotropic setting of protoplasm. In the case of higher vertebrates only nerves would be affected, whereas,

⁵ *Anesthesiology*, 2, 300. 1941.

in slime molds all the protoplasm sets thixotropically when anesthetized.

A neurologist, on observing the instantaneous cessation of movement of slime mold protoplasm when anesthetized by carbon dioxide, characterized it as paralysis. I find the analogy interesting, though prefer not using the term simply because less is known of the mechanism of paralysis than of anesthesia. It may be true, however, that paralysis, like anesthesia, is due to a thixotropic setting of the protoplasm of nerve fibers.

Thixotropic gels possess large quantities of water, often with less than 1 per cent of solid matter. A germanium or cadmium gel may have as much as 99.8 per cent water. The jelly-fish contains but 2 or 3 per cent solid matter, yet maintains its form. Such systems must be built of long and flexible fibers in order to set into firm and elastic gels. Fibers may contact each other at greater distances than do spheres, therefore, fewer units are needed to build a structure of given volume.

Further evidence of a very open structure in certain jellies is the transparency of some of them. Soap jellies are quite clear. This is possible because of an open three-dimensional lattice built of long fibrous units. The sudden locking of such intermeshing fibers accomplishes thixotropic setting; and their release by mechanical agitation is thixotropic collapse. In protoplasm, these linear units are the familiar polypeptide chains.

ELASTICITY

That protoplasm is elastic is so obvious to many workers that one wonders why it should ever have been questioned by others. The earliest students of protoplasm knew it to be elastic. Additional evidence of recent date comes from Northen⁶ and Norris⁷.

Proof of the elasticity of protoplasm is to be had in a number of ways. The simplest is to stretch it with microneedles (Fig. 2). On release after stretching, the protoplasm usually shows pronounced recoil, indicating high elastic qualities.

The elasticity of protoplasm may be demonstrated in another and rather novel way, by inserting a metal particle and attracting it electromagnetically. On elimination of the electromagnetic field the particle retraces its path due to the elasticity of the protoplasm. Evidence that the elastic qualities of protoplasm are not pathological

⁶ *Protoplasma* 31, 1-8. 1938.

⁷ *J. Cell. and Comp. Physiol.*, 16, 313. 1940.

is to be had in the migration of fibroblasts shown in moving pictures by Dr. Warren Lewis. As the fibroblasts move, they form long streamers attached to the substratum. These are later torn loose, or broken, and then snap and recoil rapidly.

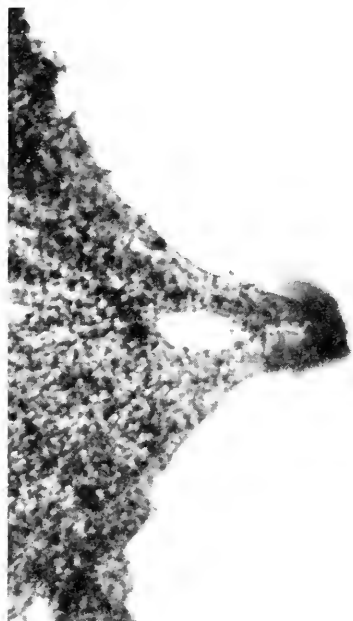

FIG. 2. The stretching of protoplasm with a microneedle. On tearing, the protoplasm rebounds, exhibiting high extensibility, tensile strength, and recoil.

The elasticity of protoplasm varies, just as do its other physical properties such as viscosity. Highly viscous protoplasm may be poorly elastic, resembling plastic paste, whereas thin protoplasm is sometimes capable of great extensibility, with pronounced recoil. From the foregoing it could be assumed that viscosity and elasticity have a direct bearing upon each other, but this is not true; they are independent variables.

Very thin protoplasm is often thought to be inelastic because the elasticity cannot be readily determined.

That thin solutions may be highly elastic is capable of nice demonstration in soap solutions.[^] Sodium stearate will, under favorable conditions, exhibit pronounced elasticity though the solution is but twice as viscous as water. The elastic quality of so thin a solution may be demonstrated by twirling the flask containing it and observing the manner in which the

solution comes to rest. A wholly inelastic liquid, such as water or glycerin, will come to rest slowly and show no return, but an elastic solution will slow down, come to a sudden stop, and then return a part of the circumference of the flask. Were it possible to apply some such method to protoplasm, I feel confident that the thinnest protoplasm would show elastic qualities just as does the thicker protoplasm in which elasticity is so readily demonstrated.

The effects of salts on the elasticity of protoplasm have been determined; calcium increases the extensibility of protoplasm,

[^] Third Colloid Symposium Mono., New York, 1925.

sodium diminishes it, and magnesium has no effect at all.⁹ The following series was obtained:



This is in keeping with the known dispersing effect of sodium and the aggregating effect of calcium on protoplasm.

Theories on the elasticity of gels have been numerous, one of the oldest being based on surface tension. It was maintained that the elastic qualities of protoplasm are due to surface forces, those same forces which cause a free liquid droplet to round up into a sphere. This is very unlikely in protoplasm, or in any gel, for the elasticity of a glutinous mass like protoplasm or gelatin is not restricted to the surface. This is obvious when a jelly is torn. Furthermore, the elasticity of protoplasm, measured in terms of extensibility, far exceeds that which could be accounted for on the basis of surface tension. When, as is usually true, the surface layer of protoplasm proves to be more elastic than the interior, this is due not to surface tension, but to a denser knitting of the fibrous molecules at the surface, i. e., to the same structural features which are responsible for elasticity throughout the living substance.

Change in surface tension entered into a theory of the structure of elastic gels. It was assumed that gelatin is a fine emulsion, and that the physical forces responsible for elastic qualities of gelatin resided in the interface between the dispersion medium and the dispersed phase. By a neat mathematical analysis Hatschek¹⁰ demonstrated that surface tension cannot possibly be responsible for the elastic qualities of jellies. If the interfacial tension between two liquids is responsible for the elasticity of the system, then the magnitude of this tension is dependent upon the amount of surface. Consequently, the product of the increase in surface, due to stretching, and a constant representing the degree of interfacial tension and extent of surface, must equal the work done in producing elongation. If stress is plotted against increase in length, the stress, in the theoretical curve, increases until elongation reaches two and a half times the original length, and then decreases, which is experimentally untrue. If the foregoing theoretical curve, plotted on the assumption that elastic qualities reside in surface forces, is compared with experimental curves of elongations of gelatin and rubber, the two are found to differ greatly in general character. Obviously, elasticity

⁹ *Rheology* 2, 263-270. 1931.

¹⁰ *Trans. Faraday Soc.*, 12, 17. 1917.

is not a surface or interfacial phenomenon, but a property of the gel as a whole, the basic mechanism of which lies in structural continuity.

There then came into colloidal chemistry the stimulating concept of a brush-heap of molecular or colloidal fibers. My earliest¹¹ interpretation of the mechanism of elasticity in protoplasm was that of a brush-heap, a haphazard distribution of molecular rods (Fig. 2, p. 4). The concept holds well for elasticity, but fails when other qualities of protoplasm and jellies in general are considered. The folded protein molecule (Fig. 4, p. 32) best meets all requirements, and is the molecular form now commonly ascribed to elastic organic substances and tissues such as albumen, wool, hair, and muscle.

A folded protein chain is the basic mechanism of both the elastic and contractile qualities of protoplasm and certain other organic substances. I shall reserve further discussion of it for the section on contractility, to follow.

Though the folded chain is the most likely molecular form responsible for the elasticity of gels, there are other possibilities of which the helix is one. The molecular structure of rubber is thought to be that of a modified helix.

That a hydrocarbon could be elastic seemed so unlikely that when it was suggested at the inaugural meeting of the Society of Rheology that those structural features responsible for the anomalous flow of gelatin, soaps, and like substances are also responsible for their non-Newtonian behavior, objection was raised on the grounds that hydrocarbon oils were found to be anomalous by Hardy, and hydrocarbons cannot be elastic. Since then, artificial rubber of high elastic qualities has been made of polymerized hydrocarbons.

An interpretation of the molecular structure of hydrocarbons such as will account for their elasticity, has been made by Mark¹², Mack¹³, and Meyer.¹⁴ They assumed the rubber molecule to be a long chain, or molecular fiber fashioned as a helical spring, which uncoils on stretching.

In order to account for an 800 per cent stretch in rubber, Mack devised a mechanism wherein the axis of one molecule is perpen-

¹¹ Amer. Naturalist, 60, 124. 1926.

¹² MARK, H., Physical Chemistry of High Polymeric Systems, N. Y. 1940. (See also Kautschuk, 6:2. 1930).

¹³ Jour. Amer. Chem. Soc., 56:2757. 1934.

¹⁴ MEYER, K., Die Hochpolymeren Verbindungen, Leipzig, 1940 (See also Chem. Revs., 25:137. 1939).

dicular to that of another to which it is attached. On stretching, the axes of the molecules are pulled into line with each other. Elongation is thus doubled. As one spiral coil will permit an extension of 300 per cent, a stretch of 600 per cent is thus obtained. This surpasses the usual 400 per cent and approaches the possible maximum of 800 per cent for rubber.

The source of energy was also given consideration.¹³ The residual valences of double bonds are insufficient because in stretched rubber they are spaced too far apart. Mack, therefore, assumed that the source of attraction lies in van der Waals' forces between hydrogen atoms attached to carbon atoms.

Contraction results, says Meyer¹⁴, because the extended state of a long chain molecule is thermodynamically a less probable one than the contracted state. The extended form has only a single geometrical possibility, whereas the contracted form has many. The extended chain will thus have a tendency to contract, and this appears to be true not only for rubber, but for all elastic synthetic polymers, for muscle, and for protoplasm. Thus we see that deductions made from considerations of rubber apply to living matter.

Proteins are the substances, and their folded chains the molecular forms probably responsible for the elasticity of protoplasm. This is the consensus of opinion, but it has had its opponents. Controversy over the form of polypeptide molecules entered early into the stereochemistry of proteins. Solid spheres, hollow spheres, chains, fibers, coils, nets, and lattices have all had their advocates. By the time most chemists had agreed on the polypeptide chain for proteins, with side-chain linkages establishing two and three dimensional lattices, there arose renewed support of the hollow sphere, based primarily on mathematical analysis.¹⁵

The chief objection to a hollow sphere is the difficulty of doing anything with it structurally. If the 32,000 molecular weight protein is a complete and closed hollow sphere in itself, it would be difficult to construct 64,000, 96,000, etc., molecules from it, as Svedberg suggests is done in nature. Mechanical properties, such as elasticity, tensile strength, and the extraordinarily high water holding capacity of jellies would be equally difficult of interpretation. To attempt to satisfy the physical properties of protoplasm with a spherical molecule is rather like asking a weaver of cloth to make his fabric of sand instead of threads.

¹³ *Science*, 85, 76. 1937.

Globular molecules are said to occur in globulins, such as edestin, and in normal albumen (egg white), but this is true only in dilute solutions and only when the molecules are not at surfaces. Furthermore, all yield X-ray photographs when denatured. According to Astbury¹⁶, the supposed globular protein molecule is a folded polypeptide chain in which the linear fiber has been thrown into a series of rings.

In some proteins, the natural molecular configuration is an extended chain, which may be fully extended as in silk, β keratin, and β myosin, or regularly folded in one dimension, as in the α - and super-contracted forms of keratin and myosin (Fig. 4, p. 32). When the chains are fully folded, so-called "globular" proteins result; among them are egg albumen, haemoglobin, pepsin, and insulin. These "globular" proteins unfold on denaturation, and the liberated polypeptide chains may then sometimes be spun into artificial protein fibers. In the living cell there is probably an unlimited number of reversible interchanges between various states of folding. From this, it follows that a spherical protein may be transformed into a fibrous one; possibly the reverse transformation may also occur. The former change has been proven experimentally (see Moyer, p. 28, this Monograph).

Evidence is predominantly in favor of but one stereochemistry of the proteins based on the convolutions of the polypeptide chain. It may be, however, that the proteins fall into two groups, morphologically considered, the soluble proteins of globular molecular form, such as egg albumen, insulin, and edestin, and the insoluble proteins with chain molecules, such as silk, hair, and wool. Protoplasm will contain both forms; the globular proteins will serve primarily as nutrition and the linear ones for construction. It is to the chain molecule that the elastic and general structural properties of protoplasm are due.

CONTRACTILITY

Elasticity and contractility are very similar phenomena, for elastic substances contract. Consequently, much that is said of the one is applicable to the other. In the conclusion to this chapter, I shall emphasize the wide-spread occurrence of rhythmic contractility in tissues, but it is a special case of which I wish first to speak, that of the continuous rhythmic pulsation of the protoplasm of slime molds.

¹⁶ Nature, 137, 803. 1936.

The mechanism of protoplasmic flow has long been a subject of speculation. Change in surface tension, the *sine qua non* of so many cellular activities, was once regarded as being responsible for the streaming of protoplasm. There was also the suggestion that the one-way shuttle type of flow in the filaments of coenocytes where movement is first in one direction and then in the other, may be due to hydration at one end and dehydration at the other end; but the protoplasm flows equally well in both directions, even when fully submerged.

With the introduction of colloidal chemistry into physiology it became apparent that many cellular activities had their counterpart in colloidal systems. There thus arose the suggestion that protoplasmic streaming is a cataphoretic migration of particles or the electroendosmotic flow of an aqueous medium; if either, it is the latter, for in streaming protoplasm the entire mass of material moves and not just the suspended particles. In spite of some attempts to prove that streaming protoplasm is associated with electric potentials, there has been no convincing evidence that the potentials measured are real in the sense of innate to the protoplasm, and if real, are the cause rather than the result of the streaming.

One difficulty with most theories advanced in explanation of protoplasmic movements is the lack of any explanation of a reversal in the mechanism. The protoplasm of slime molds flows first in one direction and then in the other. Reversal occurs normally every 45 to 50 seconds, the time of outward flow occupying about five seconds longer than that of the inward flow, which accounts for the advancement of the plasmodium. Were a difference in potential responsible there would have to be a change in polarity every 45 seconds, and there is no evidence that such a change occurs, except the reversal in flow.

If time-lapse moving pictures of the streaming protoplasm of the myxomycete, *Physarum polycephalum*, are made, a remarkable pulsation of the plasmodium is revealed. Pictures taken every five seconds and shown at the usual rate of sixteen a second, which means a speeding up of eighty times, show the plasmodium undergoing rhythmic contractility and relaxation in perfect synchronism with the protoplasmic flow (Fig. 3). The rhythmic contractions and expansions when thus optically accelerated resemble the pulsations of a heart. At each contraction and relaxation the direction of protoplasmic flow reverses, and with the outward flow the plasmodium advances slightly.

As the rhythmic contraction of the protoplasm is synchronized with the streaming, it seems likely that one is the cause of the other, from which the only constructive deduction to be made is that the flow is the result of the rhythmic movement.

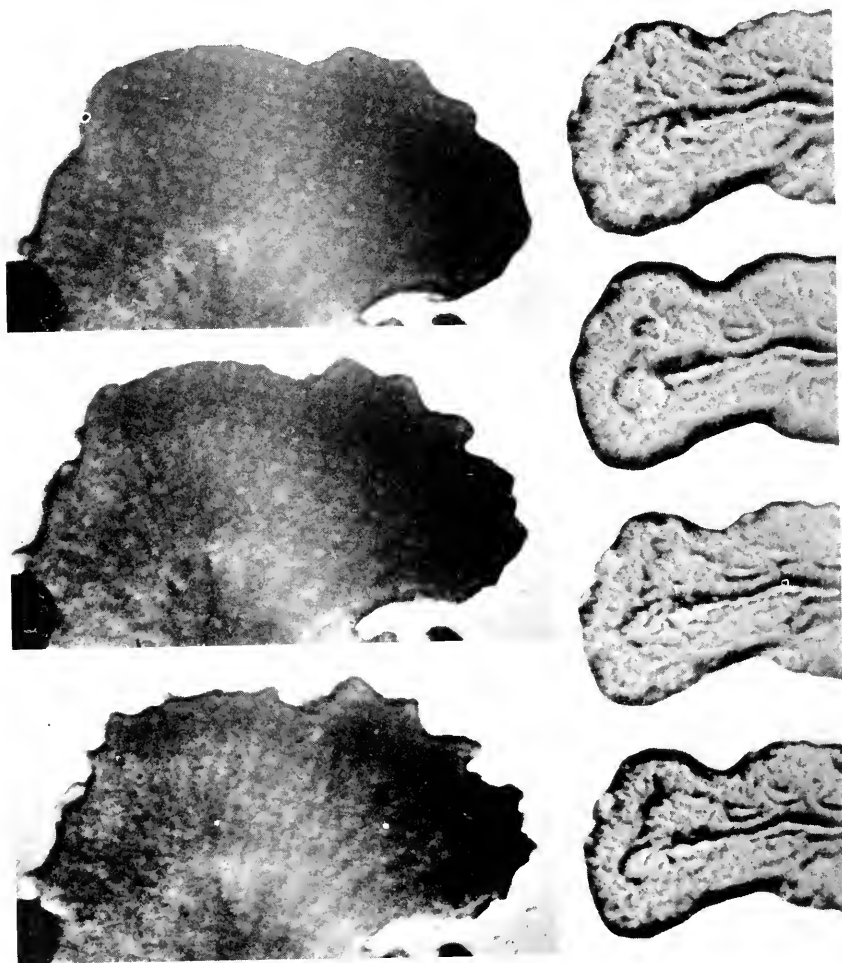

FIG. 3. The rhythmic contraction of two pseudopods of a slime mold plasmodium. The top picture in each series is the fully expanded form and the bottom picture is the fully contracted form. The three left-hand pictures were photographed 20 and 25 seconds apart. The three right-hand pictures were photographed 20, 15, and 10 seconds apart. Note that in the left-hand pictures the expanded form at the top has a smooth contour, and the contracted form at the bottom has a wrinkled contour.

The mechanism of protoplasmic movement in slime molds is, then, one of rhythmic contraction and relaxation of the plasmodium, with a total of 95 seconds for each pulsation, 45 seconds for systole and 50 seconds for diastole, the additional 5 seconds in time of outward flow account for advancement. Kamiya (p. 211) gives 93.7 seconds for one rhythmic period.

The precise nature of protoplasmic contractility is difficult of interpretation, for in slime molds it is complicated by the constantly varying shape of the plasmodium, and by a multiplicity of rhythms (see Kamiya, p. 234). The latter are the expression of a too little appreciated property of non-cellular protoplasm, namely, the presence of distinct regions, each with its own individuality, yet each contributing to the function of the whole. Moving pictures revealed three separate rhythms in slime (Figs. 14 to 17), which number Kamiya has now greatly increased. He postulates many rhythms or frequencies of pulsations.

The discovery that a plasmodium is a polyrhythmic system would at first thought seem to hopelessly complicate the situation, but actually it is only through a multiplicity of secondary pulsations that it is possible to account for a number of phenomena. Where the situation is a simple one, it is not difficult to visualize the mechanism responsible for protoplasmic flow. If there is a strand connecting two masses of protoplasm, then the mass at one end contracts and that at the other end expands, forcing the protoplasm through the connecting strand. At the end of 45 seconds the second mass undergoes contraction and the first mass now expands. The protoplasm then flows in the opposite direction for an average of 50 seconds. It is probable that in such a case contraction takes the form of a peristaltic wave which passes along the strand from one end to the other, and then returns, the process being repeated rhythmically every three-quarters of a minute.

In a situation such as the foregoing, the outer cortical layer of the protoplasm may be postulated as the region responsible for contractility and protoplasmic flow; and, with reason, it may be assumed that this surface layer is a gel, in contrast to the fluid protoplasm which is in a state of motion within, the one being readily converted into the other through a sol-gel transformation. Though in full agreement with this viewpoint where there is one general inner region of liquid and flowing endoplasm, surrounded by an outer firm and contractile ectoplasm, as in *Amoeba*, yet I do not believe so simple

a mechanism is applicable to a myxomycete plasmodium, for the following several reasons.

A plasmodium is an aggregate of many regions, each of which is a unit in itself. Each contains liquid, flowing protoplasm surrounded by firm and quiet protoplasm, and each possesses its own rhythm. Three rhythms were shown in my original moving pictures of plasmodia, and no two of the three were pulsating in unison. Were the mechanism of flow situated in a single protoplasmic part, the peripheral layer, it is hardly likely that there would be a duplicity of rhythms. One may frequently observe in a plasmodium several

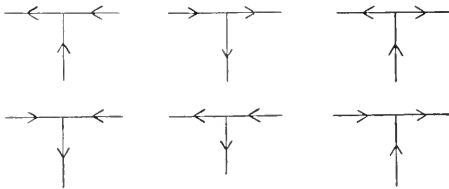

FIG. 4. Six possible combinations in direction of flow in two connecting strands.

lines of flow which cannot possibly be the expression of a single contractile mechanism. Illustrations of two such situations are shown in Figures 4 and 5. Figure 4 is a diagram of two connecting strands with arrows which indicate six possible types of flow all seen within a few minutes' time. Such a situation can be adequately accounted for only on the assumption of several frequencies not in perfect synchronism. There is a lag in the time of reversal in one strand over that in the other, which means that there is more than one center of contraction in the plasmodium.

Figure 5 illustrates another case where contraction is not centered in the surface layer, but at a point, or points, some distance in from the surface.

The six possible types of flow shown in Figure 4 are reproduced many times over by numerous small individual systems or centers of activity throughout a plasmodium. In short, there is not one surface layer of contractile protoplasm, but many secondary centers of contractility.

A situation that one would have difficulty in interpreting on the basis of a single contractile mechanism is that involving the flow of protoplasm in a globule. Were a spherical plasmodium a shell of firm contractile protoplasm enclosing a core of fluid non-contractile protoplasm, then uniform contraction of the surface would compress the inner protoplasm and not produce flow along defined channels; but if this droplet of protoplasm consists of many individual centers

of activity, each with its own rhythm, then movement from one part to another can be accounted for.

For these reasons, I regard protoplasmic movement in myxomycetes as not identical to that in *Amoeba*. There is apparently in *Amoeba* one cortical contractile layer and one major line of flow, whereas, a myxomycete consists of many regions each exhibiting rhythmic contractility which is not necessarily in perfect synchronism with its neighbors.

The most convincing evidence against a contractile cortical layer in slime mold is the wrinkled surface of a plasmodium at systole. Contraction should shorten and therefore smooth out the surface of a pseudopod as it is emptied of protoplasm. The lowest of the three photographs in Figure 3 is the contracted state of the pseudopod, yet its surface is much wrinkled, whereas, the surface of the expanded protoplasmic mass, at the top in Figure 3, is smooth. Tension at a surface should tend to round up, not buckle, the contour of a contracting fluid drop. Wrinkling of the surface with a decrease in volume because of loss of protoplasm indicates that there has been no change in the total surface area and therefore, no contractility of the surface layer. This is a matter of great importance for the whole concept of rhythmic contractility in protoplasm, and is to be explained, I think, by the conclusion expressed in the foregoing paragraph, namely, that in slime molds there is not one single contractile mechanism which resides in the surface layer, but many independent centers of rhythmic contractility.

The conclusion to which I come is similar to that reached by Pfeffer, and by Ewart, in relation to another physical force, that of surface tension, then held to be responsible for protoplasmic flow. Their deduction is as applicable to the present case as it was to their own, namely, that the energy responsible for protoplasmic flow is liberated throughout the living substance and not solely or primarily at the boundary.

Another important matter which should be emphasized is that

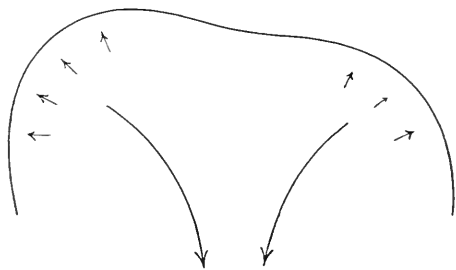

FIG. 5. Simultaneous flow both toward and away from the periphery of a plasmodium.

fluid protoplasm is contractile. Usually the contracting regions of a plasmodium are of high viscosity, but protoplasm need not be so to exhibit contractility. The significance of this remark is twofold: It emphasizes that the chief feature of protoplasmic movement is not a sol-gel transformation but the contractility of protoplasm, and that organic colloidal solutions have some of the properties of gels no matter how thin they may be.

The physical differences between streaming protoplasm and quiet protoplasm may be great, but they are purely physical and relative. Quiet protoplasm is more viscous than flowing protoplasm; it may be quite firm. It is usually more resilient, elastic, of higher tensile strength, and more contractile than flowing protoplasm, but the latter is by no means devoid of these properties. Fluid protoplasm is elastic and contractile. The experiment cited on page 250, wherein an elastic fluid was given a swish in a flask, is a demonstration of contractility in a fluid system having a viscosity value but twice that of water. The protoplasm which flows in the capillaries of a slime mold is less contractile than the surrounding protoplasm which is responsible for the flow, but it is, nevertheless, capable of exhibiting contractility.

Before turning from a purely biological discussion of rhythmic contractility in protoplasm to a physical interpretation of it, I should like to restate and further support the important concept that a plasmodium is an aggregation of centers of activity each with an individuality all its own. The physiological state of any one center differs from that of adjoining centers at any given moment very much as adjoining cells in tissue differ, with this exception, that in a plasmodium the difference is less permanent.

Further indication that a slime mold is an assemblage of individual units is to be had in the habit plasmodia have of breaking up into microscopic bits at the time of sclerotium formation, and even during the plasmodial stage. At sclerotium formation, the drying plasmodium fragments into many small sections, the whole resembling an assemblage of cells. De Bary noticed this, and it has recently been recorded for *Hemitrichia vesparium* by Ruth N. Nauss, who describes the sclerotium as made of many isolated globules of resting protoplasm. These subdivisions represent previous centers of activity which were physiologically distinct at the time the sclerotium was formed. It is possible that they are uninucleate masses of protoplasm. The bits which are morphologically separate units in a sclerotium cease to be so in a plasmodium where, however, they

retain their physiological individuality, the chief feature of which is, for us at the moment, the characteristic rhythm each possesses, a rhythm not necessarily in perfect synchronism with that of other units.

The foregoing essentially biological discussion of rhythmic contractility in protoplasm leads naturally to a physical interpretation of the phenomenon. This would be a highly speculative venture were it not for the great advance made by physical and X-ray chemists in an understanding of the molecular structure of contractile organic substances such as silk, wool, and hair. Just what has been accomplished in the case of the elasticity of rubber I have already stated (p. 253), and I added that as elasticity and contractility are part of the same general phenomenon, consideration of the physical basis of these properties of protoplasm would be postponed. We may, then, now consider the molecular structure most likely responsible for elastic and contractile properties in certain organic systems, particularly protoplasm.

Protoplasmic contractility has been attributed to a variety of forces. In the case of muscle, change in surface tension was a widely accepted theory. But today it is generally conceded that protoplasmic contractility is due to the same molecular mechanism as are the contractile properties of wool and hair, namely the folded polypeptide chain.

The elasticity of jellies and the high water-holding capacity of thixotropic gels led to the general acceptance of a linear structural unit. Contractile properties have now led to another feature of the structural unit of elastic organic systems, namely, molecular folding (Fig. 4, p. 32). With it our picture is relatively complete.

All proteins are built of polypeptide chains with side chains joining one molecule to another. Most proteins are crystalline. Usually, two classes of proteins are recognized, the fibrous and the non-fibrous or corpuscular ones, but there is so much in favor of a close relationship between the two, and a small energy difference, "that it is difficult to avoid the conclusion that fundamentally all proteins are fibrous."¹⁷

The general molecular pattern of proteins is now well known (Fig. 4, p. 51, etc.).

Astbury¹⁸ divides proteins into four types according to their

¹⁷ *Trans. Faraday Soc.*, 36, 233. 878. 1940.

¹⁸ *Tabulae Biologicae*, 17, 90. 1939.

molecular patterns: extended β -proteins, extended proteins of the collagen type, folded proteins of the α -type, and folded proteins of the supercontracted type.

To this scheme of molecular protein types, Astbury¹⁹ and others had previously added one other important structural feature, that of the grid, formed by side-chains joining one protein main-chain to another. If the paper on which the diagram of such a protein grid is printed is thrown into a series of folds parallel to the side chains, the α - or contracted protein molecular pattern is obtained. A parallel alignment of grids results in the formation of a three-dimensional lattice, or crystal.

It was a haphazardly assembled three-dimensional pattern, in a general way similar to the symmetrical pattern postulated by Astbury, which the earlier colloidal chemists had in mind when they wrote of brush-heaps; these later became more orderly in design.

Astbury²⁰ states that the contraction of muscle is due to the supercontraction of the oriented myosin, the protein which is the principal structural component of muscle. Similar suggestions had been made by Mark¹² and Meyer.¹⁴ And now we may carry the concept directly to protoplasm and say that the contractility of protoplasm is due to the supercontraction of its principal structural proteins through the folding of molecular fibers symmetrically aligned and joined one to the other by side chains so as to form a three-dimensional lattice. As this is a general conclusion of far-reaching significance in biology, it may be restated as follows: Contractility, wherever it occurs in animate nature, whether in the most elementary form of protoplasm or in highly specialized tissue, is due to the shortening of protein fibers by molecular folding. The energy for this work is supplied by the oxidative processes of the cell.

The physical basis of the mechanism of protoplasmic contractility has been set forth. The source of the energy is suggested. There remains the interesting and rather speculative question, whether the rhythm of protoplasmic movement lies in the chemical reaction which supplies the energy, or in the mechanism where the energy is used. If the energy supply is rhythmic, then there must be a periodically reversible chemical reaction in protoplasm. A number of autocyclic rhythmic reactions are known to occur in protoplasm; the glycogen-lactic-acid cycle in muscle is one. A still

¹⁹ *Fundamentals of Fiber Structure*, London. 1933.

²⁰ *Proc. Roy. Soc. London*, B 129, 307. 1940.

closer analogy is to be found in the rhythm of nerve conduction where a cycle of oxidation-reduction reactions is assumed to pass along the nerve.

The occurrence of autocyclic chemical reactions in protoplasm is not at all unlikely, but it seems more probable that the rhythm of protoplasmic flow is a visible expression of a rhythmicity which exists in the vital mechanism and not in the supply of energy. The living mechanism may show perfect rhythm even though the source of energy is in no way rhythmic. Just what rhythmic control in a vital mechanism means is as yet unknown.

In this connection the conclusion of Kamiya is important (p. 242), that "views which postulate a possible physical or chemical change accompanying the change in distribution of protoplasm as the cause of the reversal may be discarded," because the rhythmic motive force does not disappear when the streaming is artificially stopped for a time.

In closing this chapter, I wish to give some indication of the widespread occurrence of rhythmic contractility in living matter. Heart muscles contract rhythmically. The muscles of the diaphragm are induced to do so. Contractility occurs periodically as peristalsis in the walls of the intestines, the ureter, the uterus, and the Fallopian tube. Feeble rhythmic uterine contractility is by some thought to be continuous. Voluntary muscles are likewise believed to undergo rhythmic contractility during periods of apparent rest. The bladder, not functionally contractile, can be experimentally made to pulsate rhythmically.

Rhythm in the nervous control of organisms has long been known and has received added confirmation of late in work involving the electric recording of rhythmic waves from the brain.²¹ That a rhythmic train of events in the nervous system regulates certain body functions is shown by the rhythmic movement of the respiratory muscles which is not intrinsic, as in the case of the heart. Such induced rhythms are controlled by periodically recurring stimuli from the medulla. When the action of a single neuron is obtained, a clear record of periodic neural impulses is obtained, which recur in perfect rhythm.²²

The references so far, other than that of slime molds, have had to do with multicellular organisms, with tissues; but individual cells,

²¹ *Science*, 81, 597. 1935.

²² *Chemistry and Medicine*. Minneapolis, p. 261. 1940.

whether of tissue or Protista, pulsate rhythmically. Dr. Warren H. Lewis²³ has observed the pulsation of a single cell from chick heart muscle in culture. The pulsation of a heart is the expression of the many pulsations of its cells which may not be in perfect synchronism with each other, the heart rhythm being merely the resultant.

Rhythmic movements are common in lower organisms. Kamiya²⁴ gives an interesting case of it in *Euglena*. When this Protozoan is treated with certain reagents, notably acids, it undergoes rhythmic peristaltic movements. The pulsation is induced, but the capacity to undergo contractile motions and the rhythmicity are innate qualities.

All nature is rhythmic. In animate nature the visible instances of it are but outward signs of the basic rhythm in protoplasm. The rhythmic contractility of slime mold protoplasm is then but one instance of a very wide-spread phenomenon. In my belief, all protoplasm is capable of rhythmic contraction, but ordinarily exhibits it only in those tissues where it is functional.

Some modern workers are inclined to strip protoplasm of the properties of multicellular organisms, forgetting that the attributes of higher forms of life exist because they are properties of protoplasm. The protoplasm of primitive organisms is not less intricate, less responsive, nor less organized, than that of higher forms of life. It is fallacious to hold that primitive protoplasm is devoid of nervous response because it lacks a nervous system. Protoplasm is itself a nervous system; the nerves of higher organisms are but protoplasm. The properties of tissues are the properties of the protoplasm of which they are made. The rhythmic pulsations of contractile tissues in higher organisms are but grosser manifestations of the innate rhythmic contractility of protoplasm wherever found.

ACKNOWLEDGMENT

I wish to express my gratitude to Mr. William Donner and his daughter, Mrs. Curtin Winsor, and to the National Research Council, for their kindness in supplying funds which have made much of this work possible.

²³ Carnegie Inst. Pub. 363. 1926.

²⁴ Ber. Deut. Bot. Ges., 57, 231. 1939.

SUPPLEMENT

Editor's Note:

When planning the Symposium of which this Monograph is a record, it was my wish to have representatives from the three major sciences which, combined, constitute physiology. Physicists, chemists, and biologists were each to make their contribution to the structure of matter. But unfortunately a number of those who were the most interested and willing were too far away to attend. This was particularly true of collaborators among physicists and chemists abroad.

I attempted to reach our colleagues over-seas, but, out of the chaos in present-day Europe, replies from only two of them were received. These two messages are, each in its own way, exceedingly fine. I am very happy to be able to add them here. The one is from Professor Kurt H. Meyer of the École de Chimie, Geneva, Switzerland, and the other from Professor A. T. Astbury of the Textile Physics Laboratory, The University, Leeds, England.

The following is a translation of Professor Meyer's German letter, in which I have made but one change, to convert the personal reference to an impersonal one.



PROTEIN AND PROTOPLASMIC STRUCTURE

KURT H. MEYER

I should like to refer to a theory of protoplasmic structure which Seifriz and I independently advanced at about the same time. On the basis of the highly elastic extensibility of Amoebae, erythrocytes, and other cells, Seifriz, in 1929¹ concluded that the ultimate structural units of the living substance are probably linear molecules or micellae so arranged as to form a framework. We, on the other hand, in 1928² and 1929³ showed that there are two types of proteins, the fibrillar and the globular ones; the spherical form of the latter was proved by Svedberg. We demonstrated the undoubted presence of fibrous molecules, or elongated polypeptide chains, in silk, sinew, and stretched muscle. From this it followed that "the living substance is composed of a true network of primary valence chains which at several points are coated by a hydrated layer, and at other points are tied together by chemical bridges held by molecular cohesion" (today one would say residual valences or hydrogen bonds). Proof that a macroscopic change in form, such as muscular contraction, is accompanied by a change in form of protein chains, led us to the assumption³ that visible contraction and elongation in muscle or protoplasm is to be ascribed to the contraction and elongation of fibrous protein molecules, which in turn are controlled by chemical activities.

These were the older concepts. The question now arises, what contributions have since been made in support of this theory. Understanding of the change in molecular form, especially reversible form changes, is still very meager. Most noteworthy are the changes in molecular configuration observed by Gorter, van Ormondt, and Dam⁴ in egg-albumen films spread on water. At pH 5 the films are quite flat but below this pH value they are shrunken to one-tenth of their former area.

¹ Amer. Naturalist, 63, 410. 1929.

² Ber. dtsch. chem. Ges., 61. 1932, 1928.

³ Bioch. Z. 214, 253. 1929.

⁴ Proc. Acad. Wetensch. Amsterdam, 35. 838. 1932.

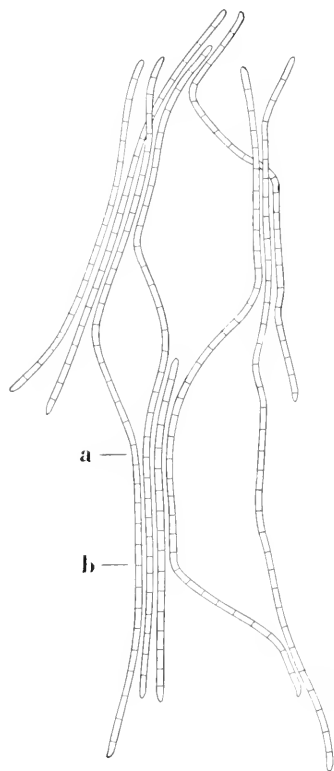

FIG. 1. This figure is by Dr. H. Mark and illustrates Dr. Kurt Meyer's concept of the molecular and micellar structure of elastic organic substances. The chains are molecules, the segments in which represent glucose units, or rather a block of glucose units, say fifteen in each segment. The micel, *a-b*, would contain some 500 glucose units. Many of the molecular chains extend through two or more micel. The loose ends of the chains are "fringes," always present, so Meyer and Mark believe. A somewhat similar scheme of micels with overlapping ends is given in Fig. 5, page 6.

The conditions which establish molecular form became evident from a comparison of acetylcellulose and acetylamylose which are distinguished only by the configuration of the glucosidal bond, β in cellulose and α in amylose. Molecules of acetylcellulose when in solution are stretched and oriented by streaming, as R. Singer has found in as yet unpublished experiments; whereas, the molecules of acetylamylose are not. From this it follows that the molecules of acetylcellulose are fibrous, and those of acetylamylose are spherical.⁸

Far better known is the relationship between chain structure and rubber-like elasticity. According to the theory which was developed by us⁵, and at about the same time by W. Busse⁶ and E. Karrer⁷, the tendency of rubber-like matter to take its original form after deformation can be ascribed to the fact that the chain molecules themselves are capable of deformation, and that parts of adjacent chains can slide one over the other just as do molecules in a viscous fluid. Stretching and orientation force molecules, which when relaxed may assume any possible shape, to take on less possible forms and arrangements. Due to kinetic energy, the thermodynamic probability that the molecules shall assume a disordered state becomes greater as soon as the external force causing deformation disappears. It follows from this that only systems containing chain molecules, the inner mobility of which is not prevented by crystallization or micel formation, can possess rubber-like elasticity. In

proteins such systems are always found as hydrated chains or chain fragments. Chain parts when coagulated or arranged in micellar fashion do not take part in elastic phenomena.

If a passively deformed object, for example, a stretched cell, loses its tension, one can conclude, that whole chains slide over each other; therefore, they must be free. If, on the contrary, no relaxation is recognizable, then the protein chains are connected to each other to form a network.

With this, I come to the matter of contact regions or the region of bonds between molecules in organic jellies. Gelatinized aqueous gelatin and gelatinized starch paste are built in the following manner: They consist of a loose network, the regions of contact being formed by micellarly arranged parts of numerous chains held together into a firm bundle. These parts or sections of numerous chains are securely bound by "lattice forces" to form a bundle. Segments of molecules protrude from the micellae ("Fransenmicelle", after Gerngross) which are hydrated and which establish ties between adjoining micelles. As a result, the micelles are united into a network of elastic and solvated molecular threads⁵. In solutions of high polymeres fewer and smaller regions of contact are sufficient to make an elastic jelly out of a viscous solution. Whether or not gelatinization takes place depends upon the medium, especially its pH, and the presence of electrolytes. Very slight changes in these properties are sufficient to bring about the formation of a jelly.

I think it not unlikely that such sol-gel changes in protoplasm are to be ascribed to the same factors, acidity and electrolytes, just as in all metabolic changes, such as the synthesis and decomposition of organic acids and acetylcholin, the binding and dissolving of phosphoric acid, etc.

Editor's Note: The concept which Professor Meyer gives us is so important that I should like to repeat part of his conclusion, and then add a figure. As I did not care to assume the responsibility of

⁵ Kolloid Zeitschrift, 59, 208. 1932.

⁶ J. Physic. Chem., 34, 2870. 1932.

⁷ Physic. Rev., 39, 857. 1932.

⁸ Further details in K. H. Meyer "Die hochpolymeren Verbindungen." Leipzig, 1940.

⁹ Helv. chim. acta 20, 1331. 1937.

the latter, I asked Dr. Mark, long collaborator with Professor Meyer, to give me a sketch such as Professor Meyer would have made.

Professor Meyer tells us that the "points" of contact between fibers are not points but regions, that there are no free chains, and that the chains are hydrated over much of their surface. In short, a chain, or part of it, is either linked to other chains or to water. Free chains do not occur owing to the high van der Waals' forces of the — OH or — CONH groups.

Editor's Second Note:

It is an especial pleasure to close this Monograph with a word from Professor Astbury. His letter gives a promise of something outstanding in the very near future, for which we shall all wait with interest. Even greater than the information he promises, is the courage he displays in carrying on with good humor under the present trying circumstances. The second from last sentence in Professor Astbury's letter expresses the spirit in which every contributor to this Monograph took part in the original Symposium. The sympathetic cooperation which Professor Astbury exemplifies is the basis of all that is worth-while in science. I am sure, too, that I express the sentiments of our Society when I say in reply to the last sentence in Professor Astbury's letter, that we, his colleagues in America, in particular those in biology who have kept so closely in touch with his work, send our gratitude for that which a good physical chemist has done for biology, and our hope that he and his fellow scientists will soon be able to carry on in a peaceful England.

The following is Professor Astbury's communication:

Dear Seifriz:

I was delighted to hear from you again, for it is an even greater pleasure than usual these days to receive letters from our American friends. Quite apart from the fact that your continuous flow of sympathy and help is tremendously heartening, you Americans have the distinction of being just about the only correspondents we have left now, outside our own Commonwealth!

Your letter by Clipper Air Mail was five weeks under way. Does this mean that the molecular structure of protoplasm is so terribly important that weeks of censorship are necessary to make absolutely certain that the enemy learns nothing about it? . . . The reprint

you mention, telling about the Symposium held at Christmas, and your scheme of turning it into a Monograph, did not reach me. I am sorry, for I should have liked very much to write something for you. Had your request arrived in good time probably I should have made a special effort, but there's so very little spare time these days, believe me! You are right in inferring that we still carry on as much as possible with work on the good proteins but, our hands and thoughts are pretty full with other things too. . . .

I have become an officer in the Air Force and am functioning as Navigation Instructor to the University Air Squadron. It is voluntary work, of course, and does not mean that I have abandoned research, just that I have to try to fit in more things during my waking hours (we don't get nearly so much sleep as we used to!) and have rather less time to think about proteins, music, and all the other things that make life worth living. I suppose that as the war goes on there will be still less and less time or opportunity for these nice things, but for the moment we are not doing too badly. Our laboratory hasn't been knocked down yet and we are still alive.

Quite recently we have had a lot of excitement because of a new advance we have made in the structure of α -keratin and β -myosin, the heroic problem of the nature of the intra-molecular folds in proteins. I really think that we have got something this time, as you Americans say; when I posted the manuscript I had almost a 'nunc dimittis' feeling about it.

You are certainly right in ascribing to me the belief that the folded protein chain is of more importance than any other structural feature in biology, or rather, the capacity of the protein chain to fold. Pauling thinks so too, I should say, to judge by his more recent publications; in any case, the problem of the fold is the same thing as that of the linkages that promote or maintain the fold, so it may well be that resonance and the hydrogen bond are of more importance to physiology than any other two facts in chemistry—provided, of course, the hydrogen bond does turn out to be pre-eminent among protein linkages, a thing we are not too sure about yet, I'm afraid. It's a pity, in one sense, that there are still so many things that we are not so sure about, though in another it is very gratifying, otherwise we should all lose our jobs! I only hope that God is not laughing too much behind His cloud at our efforts!

Speaking seriously, though, molecular biology has progressed an amazing lot these last few years, and I am happy that I have been privileged to take part in it.

We all in this laboratory send our kindest regards and good wishes to you and your associates.

Yours very sincerely,

(Signed) W. T. Astbury.

INDEX

- Abitz, W., 38
Abramson, H. A., 31, 38, 40, 97
Accumulation
 of particles by ultrasonics, 96
Acetaldehyde, 66
Acetic acid, 66
Acetylamylose, 268
Acetylcellulose, 268
Adenosine pyrophosphate, 61
Adsorption
 and dilatancy, 92
Aggregates, 68
 complex, 69, 70
 functional, 42, 71
 simple, 68
Aggregating mechanisms, 64
Aggregation, 62, 68
 complex, 69, 70, 71
 loose, 70
Albu, H. W., 97
Albumin, 60
Alcohol, 61
Aldehydes, 61
Alveoli, 2
Ambronn, H., 38, 40
Ameba; *see* Amoeba
Amino acids, 27, 28, 74
 analyses, 57
 differences, 55
 similarities, 55
Amino acid residues, 50
 distribution, 55, 57, 58
 length, 50
 number, 50, 55
Amino groups, 47
Amoeba, 23, 25, 32, 99, 100, 101, 130,
 131, 132, 133, 134, 155, 163, 165, 166,
 169, 170, 171, 172, 194, 195, 246, 257,
 267
 division of, 194
 locomotion of, 163 ff., 170-171
Amoeba dubia, 131, 133
Amoeba proteus, 133, 170, 194
Amoebocytes, 104, 133
Amoeboid locomotion, 163 ff., 171, 172
Amoeboid movement, 127, 130 ff.
Anderson, D. B., 12, 19
da C. Andrade, E. N., 98
Anesthesia, 247 ff.
 theory of, 248
Anesthetic agents, 246, 248
Anisotropy; *see also* birefringence,
 double refraction
 of dehydrated surface film, 104-105
 of myelin forms, 104
Anomalous flow, 209, 252; *see also* non-
 Newtonian
Anomalous viscosity, 32, 86, 87, 94;
 see also structural viscosity
Arbacia, 32, 34, 60, 127, 132, 133, 139,
 140, 141, 142, 143, 153, 191, 192
Arginine, 56, 67, 68
Arrangement in space, 63
Artifact, 3
Ascorbic acid, 61
 model, 67
Aspartic acid, 56
Astbury, W. T., 8, 19, 20, 27, 35, 36,
 37, 38, 254, 261, 262, 270
Atomic radii, 75
Atoms
 radii, 48
 size, 46
 structure, 46
 valence angles, 46, 47, 48
Autocomplex coacervates, 93
Balance-pressure, 166, 207 ff., 239, 240,
 241
Bailey, I. W., 11, 20
Balbach, H., 200
Banga, I., 37, 38
Barium malonate, 88
Bauer, H., 120
Beams, A. W., 38, 40
Beats, 229, 239
B ě l ě r, K., 120
Bemsley, R. R., 40
Bentonite
 thixotropy of, 88, 94
Benzopurpurin sols, 93
Berger, C. A., 116
Bergmann hypothesis, 57
Berkley, E. E., 19
Berrill, N. J., 124
Biancani, E. H., 98

- Birefringence, 24 ff., 104; *see also* anisotropy, double refraction
of cotton fibers, 17
of cytoplasm, 24-26, 31
of young fibers, 12
- Bjerknes, V., 98
- Bleb formation, 195
- deBoer, J. H., 98
- Bondy, C., 98
- Bonner, J., 107
- Boothroyd, 114
- Brachet, J., 111
- Brandt, O., 98
- Brohult, S., 98
- Brown, D. A., 32
- Brown, D. E. S., 127, 129, 130, 133, 138, 139, 140, 143, 149, 151, 153, 154, 155, 156, 157, 168, 169, 192
- Brownian movement, 89, 183, 189
and viscosity changes, 167, 181, 191
- Brush heap, 4, 34, 252
- Bull, H. B., 38
- Bungenburg de Jong, H. G., 91, 92, 98, 106, 107
- Burger, F. J., 98
- Busse, W., 268
- Cadmium gel, 249
- Calvin, M., 118
- Camp, W. G., 175, 177, 179, 182, 183, 184, 200, 201
- Carbohydrate, 61
- Carbon dioxide, 72, 73, 165, 246, 247, 248, 249
- Casein, 55
- Casperson, T., 110, 111, 112, 113
- Cattell, McK., 149, 151, 157
- Cavitation
caused by ultrasonics, 95
- Cawood, W., 98
- Cell
centrifugation of, 23, 27, 40, 127, 133, 136, 137, 138, 139, 140, 141, 143, 144
cooling and birefringence of, 26
locomotion of, 171 ff.
plasmolysis and birefringence of, 26
- Cell cleavage, 34, 139 ff., 166, 187, 190, 191
- Cell division, 138 ff., 184 ff., 193
- Cell wall, 11, 13
growth, 74
microscopic structure, 11-21
- Cell wall—*continued*
primary, 12, 13, 14
secondary, 12, 13, 14, 16, 20
- Cellulose, 4, 12
tensile strength, 5
- Cephalin, 58, 59, 65
- Certes, A., 151
- Chalkley, H. W., 194
- Chambers, R., 31, 38, 100, 102, 107, 139, 158, 183, 191, 192
- Channeling of reaction, 70
- Channels in protoplasm, 69, 70
- Charged groups, 64
- Chemical bonds, 64
- Chloroform, 246, 247
- Chlorophyll, 61, 73
model, 63
- Chromosomes
birefringence of, 24, 121
differential regions in, 114
euchromatic regions of, 113, 114
heterochromatic regions of, 113, 114
matrix of, 119
migration of, 185 ff., 189, 190
pepsin, digestion of, 111
spiral structure of, 119 ff.
trypsin, digestion of, 111
- Cilia, 128, 151
- Clays, 88, 94
- Cleavage, 34, 139 ff., 166, 187, 190, 191
- Cleveland, L. R., 119, 121
- Coacervates, 92
as colloidal state of surface films, 105, 106
autocomplex, 93
- Coacervation, 91, 106
- Coagulation
caused by ultrasonics, 96
orthokinetic, 96
proteins, 35
thixotropic and, 89, 94
- Cohesion, 49, 63, 64, 75
forces, 71
- Coils, 119 ff.
changes in direction of, 121
major, 120
minor, 120
molecular, 120
relational, 120
relic, 120
somatic, 122
standard, 120
torsion, hypothesis of, 123
- Colloidal particles
rod-shaped, 32, 87

- Colloidal solutions
 dilatancy of, 88
 elasticity of, 85 ff.
 mechanical properties of, 85 ff.
 viscosity of, 85 ff.
- Coman, D. R., 174
- Complementary faces, 65
- Conduction of nerve impulses, 149
- Configuration, 62
- Continuity
 structural, 6, 7, 8, 252
- Contractile properties, 155
- Contractile tension, 163, 166, 168, 169, 173, 174, 175, 182, 187, 189, 190, 194
- Contractility, 254 ff.
 centers of, 258
 molecular basis of, 262
 rhythmic, 243, 254, 255, 256, 259, 260, 261, 263, 264
- Coördination points, 47, 53, 55
- Coper, K., 98
- Copper, 61
- Cortical gel, 100, 127, 139, 140, 144, 153
- Costello, D. P., 139, 153
- Coulomb's law, 57
- Coult, D. F., 38, 40
- Cross-linkages, 64
- Cyclopropane, 246, 247
- Cyclosis, 135 ff.; *see also* protoplasmic streaming
- Cytochrome, 67, 69
 model, 63
- Cytoplasm, 55, 58, 59, 60, 68, 71, 75, etc.:
see also protoplasm
 diagram, 105
 gel structure in, 127-161
 particulate nature, 42, 49
 structural differentiation, 99-107
- Cystine bridges, 53, 62, 65
- Dam, 267
- Dan, K., 139
- Daniel, F. K., 97, 98
- Darlington, C. D., 113, 114, 119, 120, 123
- Dehydration
 and thixotropy, 91
 of proteins, 37
- Deuticke, H. J., 154
- Dibenzoylcystine, 88
- Dilatancy, 88, 89, 91, 92, 94, 95
 and adsorption, 92
 and dispersion medium 91
 and peptization, 91
- Dilatancy—*continued*
 and ultrasonics, 97
 vs. rheopexy
- Dinucleotides, 61
- Diphosphopyridine nucleotide, 61
- Dipole, 47
- Diptera, 110
- Disintegration
 respiration, 73
- Dispersion medium
 and thixotropy, 91
- Dognon, A., 98
- Double bond angle, 48
- Double refraction, 4; *see also* anisotropy, birefringence
 protoplasm, 24-26, 31, etc.
 streaming, 25, 29, 35, 36, 37
 tactoids, 93
- Draper, J. W., 157
- Drosophila melanogaster*, 114
- Dube, S. P., 98
- Dynamoplasmogram, 209 ff.
- Ebbecke, U., 154, 157
- Echinoderm eggs, 99, 100, 245
- Ectoplasm, 167, 257
- Ectoplast or surface film, 101-102
 molecular structure of, 105-106
- Edsall, J. T., 38, 97
- Edwards, D. J., 149, 151, 157
- Edwards, J. S., 166, 167
- Egg-albumen, 28, 267
- Egg albumin configuration, 52
- Elasticity
 colloidal solutions, 85 ff.
 cortical cytoplasm, 99-100
 inner gel layer, 102
 muscle, 33, 253
 protoplasm, 32, 249-254, etc.
 rubber, 25-26, 32-33, 252, 253, 268
 salts, effect of, 251
 soaps, 33, 250
 sols and gels, 87
 structural continuity as the basis of, 252
 thin solutions, 250
 theory, 251
- Electric potential, 235
- Electrical conductivity
 of sols and gels, 86
- Electrical field, 56, 57
- Electron-donating system, 65
- Electrostatic forces, 62, 63, 64

- Elementary particles
 ionization, 56
 of protein, 53
- Elodea, 32, 128, 132, 135, 137
- Elodea canadensis*, 137
- Emulsion, 2, 3, 106
 and ultrasonic waves, 96
- Endomitosis, 116 ff.
 in *Allium*, 117
 in *Gerris*, 116
 in hymenoptera, 117
 in mosquitoes, 116
 in spinach, 117
- Endoplasm, 100, 104, 105, 163, 164, 166-168, 171-179, 181-183, 187, 189, 190, 195, 196, 243, 257
- Engelmann, Th. W., 25, 38
- Enslin, O., 98
- Enzymes, 67, 73
 respiration, 45, 60, 61
- Ephelota, 128, 133
- Ephelota coronata*, 133
- Ergosterol, 60
- Erythrocytes, 128, 267
- Ether, 247, 248
- Ethyl alcohol, 66
- Ethylene, 247, 248
- Euglena, 243
- Euglena deses*, 243
- Euglenoid movement, 243
- Ewart, E. J., 209, 259
- Extensibility, 250, 251, 267; *see also*
 spinning capacity
 of ectoplast, 101
- Fats, 63
- Fatty acids, 58
- Fatty material, 58, 60
- Fatty substances, 46
- Fauré-Fremiet, 104, 246
- Fawcett, E. W., 154
- Feulgen reaction, 110, 111
- Fibers
 cotton, 11, 12, 14, 17
- Fibrils, 13, 17, 18, 19, 20
- Fischer, I., 115
- Flagella, 128, 151
- Flavine-adenine dinucleotide, 61
- Fluidity, 6, 8
- Fogs
 coagulation by ultrasonics, 96
- Fontaine, M., 136, 154
- Forces between particles, 93
- Formic acid, 66
- Freund, H., 98
- Freundlich H. M., 31, 32, 38, 82, 83, 84, 85, 97, 98, 152, 153, 245, 246
- Frey, A., 38, 34
- Frey-Wyssling, A., 20, 30, 38, 107, 112, 121
- Fry, H. J., 159
- Fujii, K., 120, 121
- Fundulus, 145
- Geitler, L., 114
- Gels
 collagen, 30
 double refraction of, 25
 elasticity of, 25-26, 32
 mechanical properties of, 85 ff.
 polystyrene, 29-30
 stretched, 26, 30
 structure, 29, 127 ff.
 superficial layer, 163
 thixotropic, 31, 85 ff., 153
 viscosity of, 31
- Gel formation, 29 ff.
 and solvation, 94
- Gel layers, 195, 196
 in cytoplasm, 99-100
 inner, 102
 superficial, 163, 190
- Gel-sol transformation; *see* sol-gel transformation
- Gel values, 132
- Gelatin configuration, 52, 55
- Gelatin gels
 birefringence, 25
 electrical conductivity, 86
 structural viscosity, 31
 thixotropy, 88
 X-ray pattern, 30
- Gelation, 132, 168
 relation to cleavage, 132
 relation to physiological response, 154
 relation to pressure, 132
 relation to streaming, 132
- Gelation percentages, 133, 138
- Geloids, 90, 92
- Gentcheff, G., 117
- Germanium gel, 249
- Germination of seeds
 influence of shaking on, 40
- Gerngross, O., 38
- Gibson, R. O., 154
- Gillings, D. W., 98
- Globulins, 60
- Glucose, 72, 73, 74

- Glutamic acid, 56
Glutathione, 61
 model, 63
Glycerol, 86
Glycine, 55
Goldschmidt, R., 118
Goodeve, C. F., 98
Gorin, M. H., 38
Gorter, 267
Granules
 submicroscopic, 71
Green, H., 92, 97
Grundfest, H., 149
Guanidine group, 55, 56

Hammerstein, 111
Harvey, E. B., 23, 38
Hatschek, E., 3, 251
Hauser, E. A., 94, 97, 98
Heart muscle, 60
Heilbrunn, L. V., 134, 164, 209
Heitz, E., 113, 119
Helix pomatia, 96
Heller, W., 89, 97, 98
Heme, 67
Hemitrichia vesparium, 260
Hemocyanin
 splitting by ultrasonics, 96
Herrmann, K., 38
Hexose, 69
Hexose diphosphate model, 67
Heyman, E., 98, 152, 155, 159
Hiedemann, E., 98
Hillary, B. B., 110
Hilton, A. E., 200
Hirsch, G. C., 38
Histidine, 56, 68
Hock, W., 11, 21
Hoerr, N. L., 40
Höfler, K., 102, 107
Hooker, D., 145
Höppner, 116
Howard, F. L., 173
Huskins, C. L., 109, 120, 121, 122, 123
Hyaline cap, 167, 168, 179, 180, 181, 195
Hyaline zone, 133
Hydrated protein particles, 53, 54
Hydration, 6
 and dehydration, 104, 255
 of proteins, 9, 37
Hydrocarbon, 252

Hydrogen bond, 6, 7, 8, 9, 28, 35, 49, 50,
 267, 271
Hydrogen bridge, 53, 54, 62, 64, 65, 71,
 75, 76
Hydrogen-donating residue, 66
Hydrogen ion, 65
Hydrogen ion concentration, 56
Hydrophilic groups, 54
Hydroxyl, 47, 55

Ice, 47
Imidazole ring, 55, 56
Insulin configuration, 52
Interference, 228
 intraplasmic, 229, 233, 241
Ion, 46, 68
 adsorbed, 68
 concentration, 68
 inorganic, 68, 70
Ionic bonds, 53, 71, 75, 76
Ionic linkages, 65
Ionization, 63
 acidic groups, 56
 amino and residues, 55, 56
 basic groups, 56
 protein, 55, 57
Ionized groups
 distribution, 56
Iron, 61
Iron oxide, colloidal, 86, 88, 89, 90,
 91, 95
Isoelectric point, 35, 68

Jacobj, W., 115
Jacobs, M. H., 165
Jaegar, L., 111
Jeannerat, J., 33, 39
Jelly fish, 249
Jones, A. D., 97
Juliusburger, F., 97, 98

Kamiya, N., 156, 158, 166, 199, 205, 207,
 243, 248, 257, 263, 264
Kandelaky, B. C., 98
Kaolin, 96
Karrer, 268
Keratin, 35, 254
Kerr, T., 12, 16, 19, 21, 38
King, R. L., 38, 40
Kinoplasm, 103
Kinoshita, S., 235
Kitching, J. A., 133, 151, 157
Kodani, M., 118
Kokati, M., 235

- Koller, P. C., 119
 Koltzoff, N. K., 111
 König, W., 98
 Kruyt, 91
 Kuwada, Y., 118, 121

 Lactic acid, 61
 Laing, M. E., 97
 Lamellae, 15, 16
 Lauffer, A. M., 97
 LeChatelier, 153
 Lecithin, 58, 59, 65, 91
 Leucocyte, 32, 163, 172
 Leucoplast, 73, 74
 Levans, A., 117
 Levels
 dimensional, 42, 43, 44
 molecular, 41, 45
 Levine, S., 98
 Levitt, J., 100, 107
 Lewis, W. H., 127, 155, 156, 159, 163,
 165, 166, 167, 250, 264
 Lindau, G., 97
 Linkages, 6
 Lipoidal properties of surface films,
 104-105
 Liquefaction of gels
 by ultrasonics, 95
 Liver tissue, 60
 Locomotion
 amoeboid, 163 ff.
 of amoeba, 170-171
 of cells, 171-173
 of slime mold, 173-184
 Lymphocyte, 166, 171, 172
 Lysine, 56, 68

 McClintock, B., 119
 Mack, 252, 253, 262
 Magnesium, 61
 Malic acid, 61
 Mark, H., 39, 252, 262, 270
 Marsland, D. A., 32, 39, 127, 130, 133,
 135, 138, 140, 145, 151-153, 155-158,
 168, 169, 193, 194
 Mast, S. O., 101, 127, 133, 156, 158, 159,
 163, 165, 166, 167, 169, 170, 177, 179,
 181, 182, 183, 194, 195
 Matsuura, H., 121
 Matthews, S. A., 148
 Mazia, D., 111
 Mechanical pressure
 effect on protoplasmic streaming,
 199, 200

 Mechanical properties
 of sols and gels, 85-98
 of paints, 92
 Mechanism, 72, 73, 74, 75
 cellular, 60
 micellar, 43, 44
 molecular, 43, 44, 45, 49
 Mehl, J. W., 39, 97
 Meiosis
 precocity theory of, 113
 Melanophores, 145 ff.
 Membranes
 and films, cytoplasmic, 100-103
 coacervate resemblance, 106
 lipoidal properties, 104, 105
 molecular structure, 104, 105
 plasmogel, 181
 relation to kinoplasm, 103
 undulating, 172
 Metabolie, 243
 Methylcellulose, 93, 94, 96, 153
 Metz, C. W., 116, 117
 Meyer, K. H., 33, 39, 252, 253, 262, 267,
 270
 Micellae, 3, 267
 fringed, 269
 Microdissection, 19, 32, 191; *see also*
 micromanipulation needles (*see*
 microneedles)
 Micromanipulation, 33, 100-102; *see*
 also microdissection
 oil drop technique, 101
 Microneedles, 23, 32, 33, 102, 140, 200,
 249
 Microscopic structure
 of cell wall, 11-21
 of slime mold, 182-184
 Microscopic visibility, 41
 Miller, D. C., 232
 Miller, W. A., 34, 39
 Milovidov, P., 110
 Minerals
 thixotropy, 88
 Mirsky, A. E., 34-37, 39, 40, 97, 153
 Mitosis, 165, 184 ff., 245
 Mitotic spindle, 25, 185, 187
 birefringence of, 25
 Mohl, H. von, 23, 39
 Molecular structure, 75, 76; *see also*
 structure
 of cytoplasm, 104-106, etc.
 of hydrocarbons, 252
 of protoplasm, 41-79, etc.
 Molecules: *see also* proteins
 chain, 268
 dimensions, 46

- Molecules—*continued*
fibrillar, 267
folded, 28, 252
globular, 254, 267
helix, 252, 261
linear, 267
number in protoplasm, 45, 46
organization of, 43
rod-shaped, 33
rubber, 252, 253
shapes, 46, 48
sizes, 42
sphere, 253, 254
- Monolayers of protein, 52, 53
- Moore, A. R., 26-27, 34, 39
- Mosaics, 62, 64
- Motive force, 155, 199 ff.
graphical representation of, 209 ff.
measurement of, 207-208
- Motomura, I., 139, 192
- Moyer, L. S., 23, 38, 39, 85, 254
- Mudd, E. B. H., 32, 39
- Mudd, S., 29, 32
- Muscle, 60, 128, 149
elasticity of, 33
- Muscular contraction, 33, 35, 36, 37,
149, 267
- Myelin forms, 26, 103, 104, 105, 106
- Myosin, 29, 33, 34 ff., 153, 154, 254, 262
denaturation of, 36-37
physical properties of, 25, 29, 33, 35-
37
thixotropy of, 88
- Myosin gels, 88, 132
- Mytilus edulis*, 151
- Myxomycete plasmodium, 27, 173-184,
199 ff., 246-249, 254-260; *see also*
slime mold
anesthesia, 246 ff.
as an aggregate, 258, 260
centers of activity, 258, 259
locomotion, 173 ff.
microscopic structure, 182 ff.
nucleus, 183-184
polarity, 225, 226
protoplasmic streaming, 199 ff., 255 ff.
rhythmic pulsation, 254 ff.
sclerotium, 260
viscosity, 184
- Naegeli, K. von, 3
- Nakamura, T., 121
- Nauss, R. N., 260
- Nebel, O. R., 118, 119, 120
- Nerve, 128
- Nerve impulse, 149
- Neurath, H., 39
- Newtonian liquids, 85, 86, 87
- Nitrogen, 65, 75
coördination points, 47, 53, 54, 55
groups, 55, 58, 61
- Non-Newtonian, 210
behavior, 252
flow, 209
- Non-spherical particles
and rheopexy, 95
and thixotropy, 93
spontaneous orientation, 92
- Norris, C. H., 156, 249
- Northern, H. T., 32, 39, 249
- Northern, R. T., 32, 39
- Nucleic acid, 61
desoxyribose, 110
during cell division, 112
metabolism, 118
model, 68
relation to nucleolus, 118
ribose, 110, 115, 118
role in gene reproduction, 112, 113
- Nucleic acid
starvation, 114
thymonucleic acid, 110
- Nucleolus, 118, 119, 123
- Nucleotides, 61, 66
- Nucleus
change in volume, 115, 116
energetic, 114, 124
in slime mold, 183, 184
nucleo-plasmic ratio, 115
structural differentiation, 109-126
- Oksala, T., 117
- Oleic acid, 92, 94
- Olze, A., 97
- Oncley, J. L., 39
- Organization, 63, 70, 76, 85, 164
of cell, 164
of molecules, 43
on visible level, 43
- Orientation of particles
by ultrasonics, 97
- Ormond, van, 267
- Orthokinetic coagulation, 96
- Oxide gels, 87
- Oxygen, 65, 75
- Oxygen groups, 54, 55, 58
- Painter, Th. S., 118
- Paints, 92
- Paralysis, 249
- Paramecium, 128

- Paris, 114
- Particles
 cytoplasmic, 62
 forces between, 93
 in vitro, 71
 orientation, by ultrasonics, 97
 properties, 42, 56
 protein nature, 42, 56, 58
 size, 42, 51
 size classes 41, 42, 51
- Patterns, 65, 72
 molecular, 64
 structural, 43
- Patterson, H. S., 98
- Pauling, L., 6, 7, 8, 9, 39
- Pease, D. C., 133, 138, 151, 157, 158, 223
- Peptide chains, 50, 52
- Peptizing agents, 91
- Peterfi, 246
- Pfeffer, W., 259
- Pfeiffer, H., 31, 39, 210
- Phospholipids, 58, 65, 69
- Phosphoric acid, 61, 66
- Photosynthesis, 73
- Physarum polycephalum*, 128, 156, 173, 199, 201, 246, 255
- Phytosterols, 60
- Picken, L. E. R., 39
- Pigmentary effectors, 145
- Plasmagel, 32, 131, 133-135, 138, 156, etc.
 of amoeba, 132, 155, 165, 166, 169, 170, 171, 195
 of egg cells, 139, 140, 193, 194
 of plant cells, 100, 138
 of slime mold, 174
 vs. plasmasol, 99-100, 104
- Plasmalemma, 101, 165, 166, 167, 169, 170, 195
- Plasmasol, 135, 138, 139, 165, 166, 167, 169, 170, 171, 174, 193, 194, 195, etc.
- Plasmodium; *see* Myxomycete plasmodium
- Plasmogel; *see* plasmagel
- Plasmolemma; *see* plasmalemma
- Plasmosol; *see* plasmasol
- Plowe, J. A., 33, 39, 40, 102, 107
- Poiseuille's law, 86, 208
- Polar groups, 55
 distribution, 70
 number, 66
- Polarity, 225, 235
 reversal of, 233
 spontaneous change in, 235
- Polarized light, 24, 112, 121; *see also* anisotropy, birefringence, double refraction
- Polypeptide chains, 249, 253, 254, 261, 267; *see also* peptide chains, protein chains
- Polyrhythm, 234, 236, 240, 242, 257
- Porphyrin, 67
- Pressure, 129
 balance, 166, 207 ff., 239, 240, 241
 counter, 201, 206, 207
 hydrostatic, 32, 127, 129
 mechanical, 199, 200
- Pressure bombs, 129-130
 for centrifuging, 129-130
 for microscopic examination, 130
- Preston, 5, 19
- Primary valence, 62, 63
- Prosthetic group, 61, 62, 65, 67, 69, 73, 76
- Proteins, 8, 46, 49, 53, 55, 60, 72, 253
 aggregates, 58
 and protoplasmic structure, 23-40
 backbone, 50, 54
 basic, 68
 chains, 53, 55, 61, 73, 74
 coagulation, 35
 complex, 70
 component, 67
 configuration, 51, 52, 54, 56
 corpuscular, 27, 28, 33, 35
 cube, 53, 69
 cytoplasmic, 33-38, 40
 denaturation, 33, 35, 36
 dimensions, 50, 53
 discs, 53, 56
 elasticity, 32-33, 34, 35
 elementary particles, 69
 fibrous, 27, 28, 35-37
 folded, 28, 252
 globular, 37, 254, 267
 molecular weight, 51, 58
 molecules proportional number, 69
 monolayers of, 52, 53
 packets, 52, 53, 54, 55
 particle, 62, 63, 64, 65
 particles and separation, 70
 shape, 28
 side chains, 50, 54
 specific, 62
 spinning capacity, 33
 streaming double refraction, 25, 29, 35, 36, 37
 structure, 27-29, 35-36, 50, 62
 surface, 62, 64
 synthesis, 72
 thixotropy, 31-32
 viscosity, 31, 35
- Proton, 49

- Protoplasm
 anesthesia, 247 ff.
 atomic constituents, 47
 centrifugation, 23, 27: *see also* cen-
 trifugation of cells
 cold, effect of, 26
 components, 71
 composition, 1, 69
 contractility, 254-265
 double refraction, 24-26, 31: *see also*
 anisotropy
 elasticity, 32-33, 249-254
 emulsion droplets in, 23
 gelatinization of, 248
 "a going concern", 72
 liquefaction of, 245
 local regions in, 30-31
 mechanical properties, 85 ff.
 microscopic appearance, 23
 miscibility with water, 26
 molecular constituents, 45, 46
 physical properties, 245 ff., 263, etc
 polyrhythm, 234, 236, 240, 242, 257
 proteins of, 33-38, 40, etc.
 rod-shaped bodies in, 26-27
 statistical isotropy of, 25
 structural viscosity of, 31, 32: *see*
also anomalous, non-Newtonian
 thixotropic setting of, 246, 248, 249
 thixotropy of, 31-32
 water in, 26
- Protoplasmic streaming (flow)
 cause of, 169
 effect of hydrostatic pressure on, 32,
 135-138
 effect of mechanical pressure on, 199,
 200
 effect of pressure difference on, 205-
 206
 fountain streaming, 169
 in relation to gel structure, 127-161
 mechanism of, 255 ff.
 motive force, 155, 199, 207 ff., 209 ff.
 physical aspects of, 199-244
 theories of, 155, 255 ff.
 velocity, 136, 206
 volume change in relation to, 155
- Protoplasmic structure, 1 ff. (introduc-
 tion)
 molecular aspects of, 41-79
 physical properties in relation to,
 245-265
 proteins and, 23-40, 267-269
- Protoplasmic surface film, 100-101
- Protoplasmic volume, 129
- Protoplast structure (a poem), 107
- Pseudopod: *see* pseudopodium
- Pseudopodium, 23, 130-135, 148, 165,
 168, 170, 171, 172, 174, 175, 180, 181,
 187, 193, 195, 256
- Pseudopodium—*continued*
 birefringence of, 25
 form of, 134-135
 ruffle, 172
 stability of, 135
 withdrawal of, 187
- Pyridine nucleotid, 67, 69
- Pyruvic acid, 61
- Quimfe, G., 97
- Rana, 152
- Raw materials, 72, 73
- Reaction chambers, 70
- Recklinghausen, H., 97
- Reed, C. E., 97, 98
- Regnard, P., 151
- Residual charges, 49
- Residue, length, 66
- Resonance, 9, 271
- Respiration, 60, 72, 73
- Reynolds, O., 88, 97
- Rheopexy, 94, 95
 and ultrasonics, 96
 vs. dilatancy, 95
- Rhythm, 210 ff., 242 ff., 255 ff.
 graphical representation of (plasma-
 modium), 210 ff.
 in *Euglena*, 243, 264
 in *Myxomycete plasmodium*, 210 ff.,
 246, 255 ff.
 interference, 228, 229, 233, 241
 occurrence, 263, 264
 polyrhythm, 234, 236, 240, 242, 257
- Riboflavin phosphate, 61, 69
- Rinne, F., 26, 39
- Röder, H. L., 97, 98
- Rogowski, F., 98
- Rubber
 structure, 252
 birefringence, 25, 26
- Rugh, R., 152
- Sameshima, I., 97
- Scarth, G. W., 32, 33, 39, 99, 107
- Schalek, E., 97, 245
- Schechtman, A. M., 139, 191, 193, 194
- Schmidt, O., 97
- Schmidt, W. J., 39, 40, 104, 107
- Schmitt, F. O., 39, 40, 112
- Schultz, J., 113, 114
- Schulze-Hardy rule, 89
- Sciara, 116

- Sclerotium
 fragmentation of, 260
- Sea urchin egg
 centrifugation, 23
 double refraction, 34
 fertilization, 34, 37
 proteins, 34-37
- Seifriz, W., 1, 21, 30, 32, 33, 38, 39, 40,
 97, 156, 243, 245, 267
- Sensitization, 91
- Separation distances, 65
- Serine, 56, 65, 67
- Shmargon, E. N., 114
- Side chains, 6, 8, 50, 54
- Silicic acid, dilatancy, 88
- Silk, 254
 configuration, 52
 elastic properties, 33
- Simha, R., 39
- Siminovitch, D., 100, 107
- Singer, R., 268
- Single bond angle, 47, 48
- Slime mold, 163, 167, 168, 195, 246-249,
 254-260; *see also* Myxomycete
 plasmodium
 locomotion of, 173-182
 pseudopods of, 180, 195
- Smith, S. G., 117, 119
- Smokes
 coagulation by ultrasonics, 96
- Soaps
 anomalous flow, 252
 elasticity, 32, 250
 electrical conductivity, 86
 jelly, 249
- Sodium stearate, 250
- Sols
 mechanical properties, 85 ff.
- Sol-gel equilibria, 128, 144
 in relation to pressure, 132
 in relation to temperature, 139, 153
 types of, 152, 153
- Sol-gel transformation, 85, 93, 94, 99,
 127, 193, 257, 260
- Solution of protoplasmic gels, 127, 175,
 176
 quantitative measurements, 128
 relation to cell function, 128, 129
 relation to protoplasmic streaming,
 128, 129, 136
 reversibility, 128, 140, 141
 specific examples, 127, 128
- Söllner, K., 85, 97, 98
- Solvation
 and gel formation, 94
- Southorn, W. A., 98
- Sparrow, A. H., 120, 122
- Specific area, 67
- Specific protein, 62
- Specificity
 degrees of, 66
 of molecules, 68
- Spindle; *see* mitotic spindle
- Spinning capacity, 33
- Sponsler, O. L., 41
- Stability, 65
- Stanley, W. M., 97
- Starch
 dilatancy of, 88, 92
 grain, 73, 74
 thixotropy, 92
- Staudinger, H., 29-30, 40
- Stern, C., 124
- Stern, E., 100
- Sterols, 58, 59, 60, 65
- Strasburger, E., 103
- Streaming
 double refraction, 25, 29, 35, 36, 37
 of protoplasm; *see* protoplasmic
 streaming
- Strongylocentrotus, 34, 192
- Structure
 cellulose, 4
 elasticity in relation to, 8, 257
 emulsion, 2, 3
 energy vs., 1
 fibrillar, 17
 gel, 4, 252
 granular, 2
 micellar, 3, 269
 proteins, 27-29, 35-36, 41 ff., etc.
 protoplasm, 1 ff., 23 ff., 41 ff., 85 ff.,
 99 ff., 245 ff., 267 ff., etc.
 synthesis, 72
- Structural continuity, 6, 7, 8, 252
- Structural differentiation
 cytoplasm, 99-107
 nucleus, 109-126
- Structural viscosity, 31, 32, 35, 96; *see*
also anomalous viscosity, anoma-
 lous flow, non-Newtonian liquids
- Substrate, 67, 69, 70
- Succinic, 66
- Succinic acid, 61
- Sulphur, 61
- Surface films, 100-103
 molecular structure, 104-106
- Surface tension, 251, 255, 261
- Suspensions
 dilatancy, 89

- Suspensions—*continued*
 thixotropy, 88, 89
 ultrasonics, effect on, 96
- Svedberg, T., 40, 253, 267
- Szegvary, A., 97, 245
- Szent-Györgyi, A., 37-38
- Tactoids, 92, 93
 in mixed sols, 93
- Taxis, 242
- Temperature, 65
- Tensile strength, 5, 6
- Tension
 at a surface, 259
 contractile, 163, 165, 166, 168, 169,
 173, 174, 175, 182, 187, 189, 190,
 194
- Tetrahedral angle, 47
- Tetranucleotides, 61
- Thiamine model, 63
- Thiamine pyrophosphate, 61, 69
- Thixotropic gels, 31, 85 ff., 153
- Thixotropic setting, 246, 249
 anesthesia due to, 248
 bentonite sols, 94
- Thixotropic sols, 86
- Thixotropy, 85-96, 245-249
 and coagulation, 89, 94
 and light absorption, 90
 and nonspherical particles, 93
 and peptization, 91
 definition, 246
 of gels, 31
 of protoplasm, 31-32, 245 ff.
 of oxide gels, 87, 89
- Thymonucleic acid, 110
- Tobacco mosaic virus, 29, 88
- Tonoplast, 101-102
- Tradescantia, 120
- Trillium, 100, 114, 120, 122
- Triose, 69
- Triturus torosus*, 191, 192
- Tyrosine, 56, 65
- Ullrich, H., 26, 40
- Ultrasonic waves, 95
 coagulating action, 96
 dispersing action, 95
 liquefaction of gels, 95
- Vacuoles
 submicroscopic, 69, 70
- Valence angles, 75
- Van der Waals' forces, 62, 64, 65, 71,
 75, 76, 92, 253, 270
- Vanadium pentoxide, 90, 93, 94
- Vassy, E., 97
- Verwey, E. J., 98
- Verworn, M., 97
- Viscosity
 anomalous, 33, 86, 87, 94; *see also*
 anomalous flow, non-Newtonian
 liquids, structural viscosity
 calcium ion in relation to, 164
 change due to CO₂, 165
 colloidal solutions, 85 ff.
 gels, 31
 local changes, 167
 measurement, 208
 motive force vs., 209
 protoplasm, 31-32, 164 ff., 208, 209,
 210
 rapid change, 8
 regulation and polarization, 168
 slime mold, 176, 177, 184, 208, 209,
 210
- Volume change in relation to stream-
 ing, 155
- Vouk, V., 211
- Vries, H. de, 101
- Wall: *see* cell wall
- Watanabe, A., 235
- Water
 aggregation of, 47, 48
 electrical fields, 47
 molecule, 7
 radius, 47
 shells, 64
 structure, 47, 48
- Wedmore, E. B., 232
- Wermel, E. M., 115
- White, M. J. D., 114, 119
- Wilson, E. B., 97
- Wilson, G. B., 114, 120, 122
- Wipf, L., 117
- X-rays
 breakage effects, 121
 diffraction, 112
- Yield value, 86, 207
- Zein configuration, 52
- Zocher, H., 97
- Zocher, H. Z., 98
- Zwitter ion, 65

