



**US Army Corps
of Engineers**
Waterways Experiment
Station

Technologies for Assessing the Geologic and Geomorphic History of Coasts

by *Andrew Morang*
Coastal Engineering Research Center

Joann Mossa
University of Florida

Robert J. Larson
Geotechnical Laboratory



Approved For Public Release; Distribution Is Unlimited



EB
450
.T45
no. CERC-
93-5

The contents of this report are not to be used for advertising, publication, or promotional purposes. Citation of trade names does not constitute an official endorsement or approval of the use of such commercial products.



PRINTED ON RECYCLED PAPER

DEMCO

CERC 93-5
Technical Report

Technical Report CERC-93-5
March 1993

Technologies for Assessing the Geologic and Geomorphic History of Coasts

by Andrew Morang
Coastal Engineering Research Center

U.S. Army Corps of Engineers
Waterways Experiment Station
3909 Halls Ferry Road
Vicksburg, MS 39180-6199

Joann Mossa

Department of Geography
University of Florida
Gainesville, FL 32611

Robert J. Larson
Geotechnical Laboratory

U.S. Army Corps of Engineers
Waterways Experiment Station
3909 Halls Ferry Road
Vicksburg, MS 39180-6199



Final report

Approved for public release; distribution is unlimited

Prepared for U.S. Army Corps of Engineers
Washington, DC 20314-1000

Under Work Unit 32538



**US Army Corps
of Engineers**
Waterways Experiment
Station

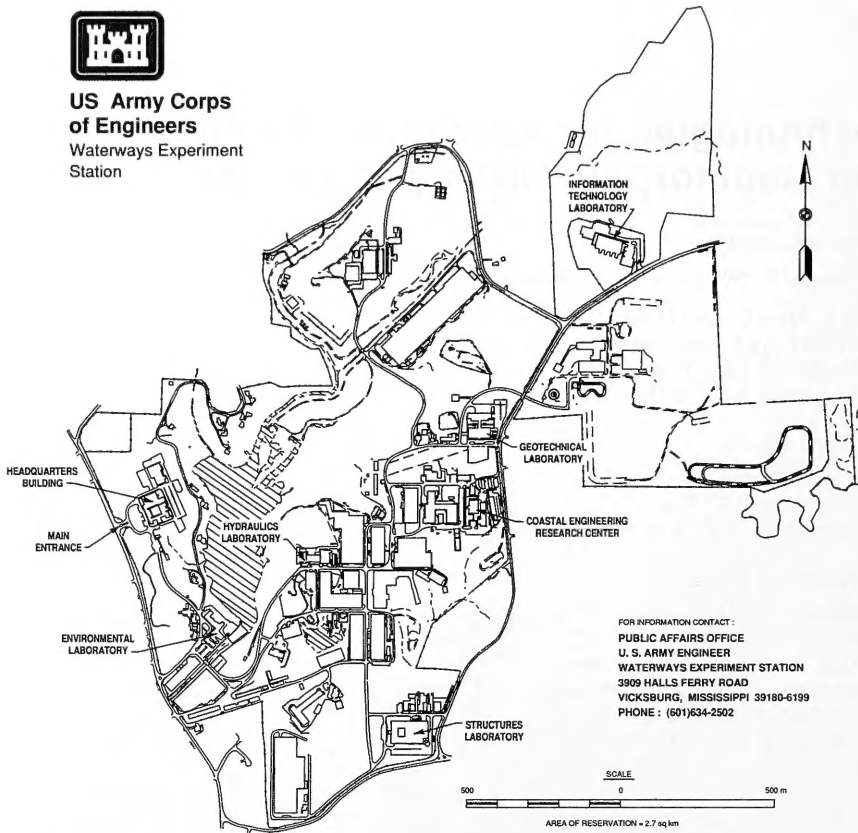

FOR INFORMATION CONTACT:
PUBLIC AFFAIRS OFFICE
U. S. ARMY ENGINEER
WATERWAYS EXPERIMENT STATION
3909 HALLS FERRY ROAD
VICKSBURG, MISSISSIPPI 39180-6199
PHONE: (601)634-2502

Waterways Experiment Station Cataloging-in-Publication Data

Morang, Andrew.

Technologies for assessing the geologic and geomorphic history of coasts / by Andrew Morang, Coastal Engineering Research Center, Joann Mossa, Robert J. Larson ; prepared for U.S. Army Corps of Engineers.

173 p. : ill. ; 28 cm. — (Technical report ; CERC-93-5)

Includes bibliographical references.

1. Geomorphology — Methodology. 2. Coast changes. I. Mossa, Joann. II. Larson, Robert J. III. United States. Army. Corps of Engineers. IV. Coastal Engineering Research Center (U.S.) V. U.S. Army Engineer Waterways Experiment Station. VI. Title. VII. Series: Technical report (U.S. Army Engineer Waterways Experiment Station) ; CERC-93-5.

TA7 W34 no.CERC-93-5

Contents

Preface	ix
Conversion Factors, Non-SI to SI Units of Measurement	x
1—Introduction	1
Background	1
Environmental and Geologic Factors Affecting Coasts	4
Scope	7
2—Sources of Existing Coastal Information	9
Literature Sources	9
Meteorological and Climatic Data	11
Wave Data	11
Water Level Data	12
Geologic and Sediment Data	19
Sources of Aerial Photography	22
Satellite Remotely Sensed Data	23
Topographic and Bathymetric Data	27
Shoreline Change Maps	27
3—Field Data Collection and Observation	29
Site Inspection and Local Resources	30
Photographs and Time Sequences	31
Wave Measurements and Observations	31
Water Level Measurements and Observations	35
Current Measurements and Observations	36
Grab Sampling and Samplers	41
Stratigraphic Sampling	42
Sediment Movement and Surface Forms	46
Navigation and Positioning Equipment	55
Geophysical Techniques	56
Morphologic and Bathymetric Profiles	62
Prototype Monitoring	65

4—Laboratory Techniques and Approaches	66
Laboratory Observation and Experiment	66
Physical Models	76
5—Analysis and Interpretation of Coastal Data	80
Wave Records	81
Water Level Records	92
Current Records	95
Maps and Photographs	105
Topographic and Bathymetric Data	109
Coastal Data Interpretation with Numerical Models	120
6—Summary and Conclusions	124
References	127
Appendix A: Glossary	A1
Appendix B: List of Wave Information Studies (WIS) Reports	B1
Appendix C: List of Selected Sources for Aerial Photography and Other Remote Sensing Data	C1
Appendix D: Addresses of Government Agencies Producing Maps	D1
Appendix E: List of Journals That Contain Articles Pertaining to the Geologic and Geomorphic History of Coasts	E1
Appendix F: Field Reconnaissance for Coastal Erosion Study, Site Visit Checklist	F1

List of Figures

Figure 1. Some techniques for studying geomorphic changes of coasts over various time scales	3
Figure 2. A three-dimensional view of some features commonly associated with a barrier island system, including the back barrier, overwash fans, and lagoons	4
Figure 3. Surface and subsurface environments and variations of barrier islands, strand plain coasts, and tidal flats	5

Figure 4. Morphology of microtidal, mesotidal, and macrotidal coastlines (modified from Hayes (1976))	6
Figure 5. Littoral Environmental Observation forms used by the volunteer observers participating in the LEO program	13
Figure 6. Late Quaternary sea level curves inferred from radiocarbon dated samples along the U.S. coastlines.	14
Figure 7. Monthly water level changes at Juneau, AK	16
Figure 8. Monthly water level changes at Galveston, TX	16
Figure 9. Yearly mean sea level changes at Juneau, AK, from 1936-1986	17
Figure 10. Yearly mean sea level changes at Galveston, TX, from 1908-1986	17
Figure 11. Typical tide curve for Oregon coast	19
Figure 12. The reference zero point for IGLD 1985 at Rimouski, Quebec is shown in its vertical and horizontal relationship to the Great Lakes-St. Lawrence River System	21
Figure 13. SPOT satellite image, Atchafalaya Bay, LA	24
Figure 14. Northeast Gulf of Mexico, February 1990. NOAA 10 satellite, AVHRR Channel 4	25
Figure 15. Spectral resolution and approximate spatial resolution of sensors on LANDSAT, SPOT, and NOAA satellites	26
Figure 16. Bottom-mounted Sea Data TM 635-12 directional wave gage mounted in tripod using railroad wheels as corner weights	34
Figure 17. Tidal elevations from seven stations in Choctawhatchee Bay and vicinity, Florida	37
Figure 18. Trench excavated in the edge of a sand dune, eastern Alabama near Alabama/Florida state line	44
Figure 19. Front view of lightweight vibracorer mounted on a barge	46
Figure 20. Rotary drilling operations under way in the estuary of the Guayacan River, Ecuador	48

Figure 21. Side view of steel frame and polyester mesh sediment trap used at Duck, NC, by Kraus (1987) during CERC's DUCK-85 field experiments	49
Figure 22. Plan view of basic ripple types (modified from Allen 1968) . .	52
Figure 23. Two- and three-dimensional bed forms	53
Figure 24. Velocity-grain size relationships for subaqueous bed forms . .	54
Figure 25. Principles of obtaining subbottom seismic data	60
Figure 26. Side-scan sonar in operation	61
Figure 27. Sample form for core description of sedimentary environments	71
Figure 28. Photograph of a portion of the Los Angeles/Long Beach Harbor physical model	78
Figure 29. Comparison of wave gage pressure measurements recorded at Long Beach sta 1 and 2	79
Figure 30. Example of continuous wave pressure record and wave burst sampling of pressure data	82
Figure 31. Pressure data collected by two gages mounted on a tripod off Mobile Bay, Alabama	84
Figure 32. Example of a single wave burst of 1,024 pressure points from the same gages that produced the records in Figure 31	84
Figure 33. Analyzed wave data from Burns Harbor, Indiana	85
Figure 34. Pressure data from Burns Harbor, Indiana, April 6, 1988	86
Figure 35. Example of tabular summary of wave data from offshore Fort Walton Beach, Florida	90
Figure 36. Plots of wave height, peak period, and peak direction from offshore Fort Walton Beach, Florida	91
Figure 37. Coastal currents measured off Fort Walton Beach, Florida Panhandle	97
Figure 38. Current measurement stations in East Pass Inlet, Destin, Florida, during October, 1983	99

Figure 39. Example of hand-written field notes listing times and data values of East Pass current measurements	100
Figure 40. Time series plots of current speed (bottom) and direction (top)	101
Figure 41. Morphologic indicators of littoral drift along natural and modified shorelines	106
Figure 42. Changes in shoreline position near St. Marys entrance, Florida-Georgia (from Kraus and Gorman 1993)	107
Figure 43. Example of a hand-annotated hydrographic map from a Florida project site	110
Figure 44. Digitally collected hydrographic data from a Florida project site	112
Figure 45. Surface grid computed by CPS-3 based on the data shown in Figure 44	113
Figure 46. Contoured bathymetry of the same area shown in Figures 44 and 45	115
Figure 47. Overall growth of an ebb-tidal shoal over 24 years is shown by the advance of the 15-ft isobath	116
Figure 48. Isopach map showing overall changes in bottom configuration between 1967 and 1990 at East Pass, Florida	117
Figure 49. Growth of the ebb-tidal shoal at East Pass, FL	118
Figure 50. Classification of beach change models (Kraus 1989)	121
Figure 51. Flowchart for studies of coastal geology	125

List of Tables

Table 1. Tidal Datums and Definitions, Yaquina Bay, Oregon	20
Table 2. Low Water (chart) Datum for IGLD 1955 and IGLD 1985	21
Table 3. Self-Contained and Cable-Telemetry Wave Gages; Advantages and Disadvantages	33
Table 4. Wave Gage Placement for Coastal Project Monitoring	35

Table 5.	Subaqueous Soil Sampling Without Drill Rigs and Casing	45
Table 6.	Maximum Allowable Errors for Hydrographic Surveys	56
Table 7.	Allowable Horizontal Positioning System Criteria	57
Table 8.	Example of Beach Fill Area Profile Survey Scheme	63
Table 9.	Sediment Particle Sizes	67
Table 10.	Minimum Weight of Sample Required Given Maximum Particle Size in Population	68
Table 11.	Wave Data Sampling Intervals, Typical CERC Projects	83
Table 12.	Sea State Parameters	87
Table 13.	Reporting Conventions for Directional Environmental Measurements	88
Table 14.	Short-Term Sea-Level Changes Along Open Coastlines	92
Table 15.	Long-Term Causes of Changes in Relative Sea Level	93

Preface

This report is based on research carried out at the Coastal Engineering Research Center (CERC) and the Geotechnical Laboratory (GL) of the U.S. Army Engineer Waterways Experiment Station (WES) under the "Survey of Technologies in Coastal Geology" Work Unit 32538, Coastal Geology and Geotechnical Program, authorized by the U.S. Army Corps of Engineers (USACE). Messrs. John H. Lockhart, Jr., John G. Housley, Barry W. Holliday, and David A. Roellig were USACE Technical Monitors. Ms. Carolyn Holmes is CERC Program Manager.

This report was prepared by Mr. Andrew Morang, CERC, Dr. Joann Mossa, Department of Geography, University of Florida, while under contract at CERC through the U.S. Army Summer Faculty Research and Engineering Program, and Mr. Robert J. Larson, GL, Earthquake Engineering and Geosciences Division (EEGD), Geologic Environments Analysis Section. Dr. Mossa and Mr. Morang worked in the Coastal Geology Unit, Coastal Structures and Evaluation Branch (CSEB), Engineering Development Division (EDD), under the general direction of Mr. Thomas W. Richardson, Chief, EDD, and Ms. Joan Pope, Chief, CSEB. Mr. Larson was under the general direction of Dr. Lawson M. Smith, Chief, Engineering Geology Branch, and Dr. Arley G. Franklin, Chief, EEGD. The report was reviewed by Mr. Steve Chesser, U.S. Army Engineer District, Portland, Mr. Danny W. Harrelson, GL, and Dr. Paul F. Hadala, GL.

Director of CERC during the investigation was Dr. James R. Houston, and Assistant Director was Mr. Charles C. Calhoun, Jr. Director of the Geotechnical Laboratory during the investigation was Dr. William F. Marcuson III, and Assistant Director was Dr. Paul F. Hadala. Director of WES during publication of this report was Dr. Robert W. Whalin. Commander was COL Leonard G. Hassell, EN.

Conversion Factors, Non-SI to SI Units of Measurement

Non-SI units of measurement used in this report can be converted to SI units as follows¹:

Multiply	By	To Obtain
cubic feet	0.02832	cubic metres
cubic yards	0.7646	cubic metres
feet	0.3048	metres
feet per second	0.3048	metres per second
inches	2.540	centimetres
miles (U.S. statute)	1.609	kilometres
miles (U.S. nautical)	1.852	kilometres
pounds per square inch	703.1	kilograms per square metre
square miles	2.590	square kilometres
knots	1.852	kilometres per hour

¹ Some data examples are presented in English units, in accordance with the units used during the original data collection.

1 Introduction

Background

Coastal environments display great geologic and geomorphic¹ diversity over space and time. Spatial diversity occurs because coastal landforms develop in a variety of terrestrial and marine environments from a variety of rocks and sediments. Environmental factors, such as coastal winds, waves, tides, currents, storms, sea level, tectonics, sediment supply, and human influences, cause vast geographic variation. Temporal diversity in landforms and materials occurs largely because environmental factors fluctuate over time. These environmental variations may be cyclic, noncyclic, or unidirectional over the time period examined. As a result, the geologic and geomorphic history of a coastal area is a response to a multiplicity of environmental factors over a variety of time scales.

The assimilation of evidence and the interpretation of geologic and geomorphic history of a coastal area require an understanding of the system's dynamics and its response to temporal and spatial environmental changes. Each facet of the coastal system is constantly changing and each altered facet influences subsequent changes to the system. Data which indicate the rates, magnitude, and frequency of phenomena such as the effects of storms, sea level rise, coastal erosion, or the subsidence of continental margins, are important for understanding the history and current status of geologic systems. The understanding is significant to a variety of issues, including predicting and planning for coastal hazards and engineering design of coastal structures.

Three principal time scales are important in assessing the geologic and geomorphic changes of coasts. These include: (1) modern studies, which are based largely on field data or laboratory and office experiments of environmental processes; (2) historic studies, which are based largely on information from maps, photography, archives, and other sources; and (3) studies of paleoenvironments, which are based largely on stratigraphy and

¹Geomorphic refers to the description and evolution of the earth's topographic features - surficial landforms shaped by winds, waves, ice, flowing water, and chemical processes.

associated geological principles (Figure 1). These general categories overlap. Furthermore, within each of the categories, certain time scales may be of particular importance for influencing coastal changes. For example, tidal and seasonal changes are significant in modern studies, and Holocene sea level history is important in paleoenvironmental studies. Tidal fluctuations are difficult to detect in studies of paleoenvironmental changes, and sea level typically changes too slowly to be an important factor in modern process studies.

Several lines of inquiry are available to assess the geologic and geomorphic history of coasts. One means of acquiring coastal data is through field data collection and observation. These data may be numerical or non-numerical, and may be analyzed in the field, laboratory, or office. Laboratory studies are used to collect data through physical model experiments, such as in wave tanks, or to analyze geological properties of field data, such as grain size or mineralogy. Office studies include interpretation of historic maps, photographs, and references, as well as analyses and numerical simulation of field, laboratory, and office data. Typically, the best overall understanding of environmental processes and the geologic history of coasts is acquired through a broad-based combination of techniques and lines of inquiry.

The quality of the results depends on several factors. Among these is the use of existing data. If secondary data sources (i.e. existing maps, photography, and literature sources) are limited or unavailable, assessing the geologic history will be more difficult, more costly, and typically more inaccurate. Consequently, before initiating detailed field, laboratory, or office studies, thorough literature review and search for secondary data sources should be conducted. This report lists sources and agencies that can be consulted in searches for secondary data of various types.

The quality of the research equipment, techniques, and facilities also influences the quality of the evaluation of geologic and geomorphic history. For example, echo-sounding and navigation instruments used to conduct bathymetric surveys have recently been improved. If such equipment is available, the mapping of geologic and geomorphic features can be extended further seaward to a higher degree of accuracy than was previously possible. It is important that the coastal geologist and engineer stay abreast of new techniques and methods, such as remote sensing and geophysical surveys, computer software and hardware developments, and new laboratory methods. For example, recent developments in Geographic Information Systems (GIS) enable the coastal scientist to analyze and interpret highly complex spatial data sets. This report describes some recent developments and techniques that are used in the analysis of coastal data sets.

Scientists must recognize certain problems and assumptions involved in data collection and analyses and make adjustments for them before making an interpretation. It is critical to account for various sources of error in preparing estimates of coastal changes and acknowledge the limitations of

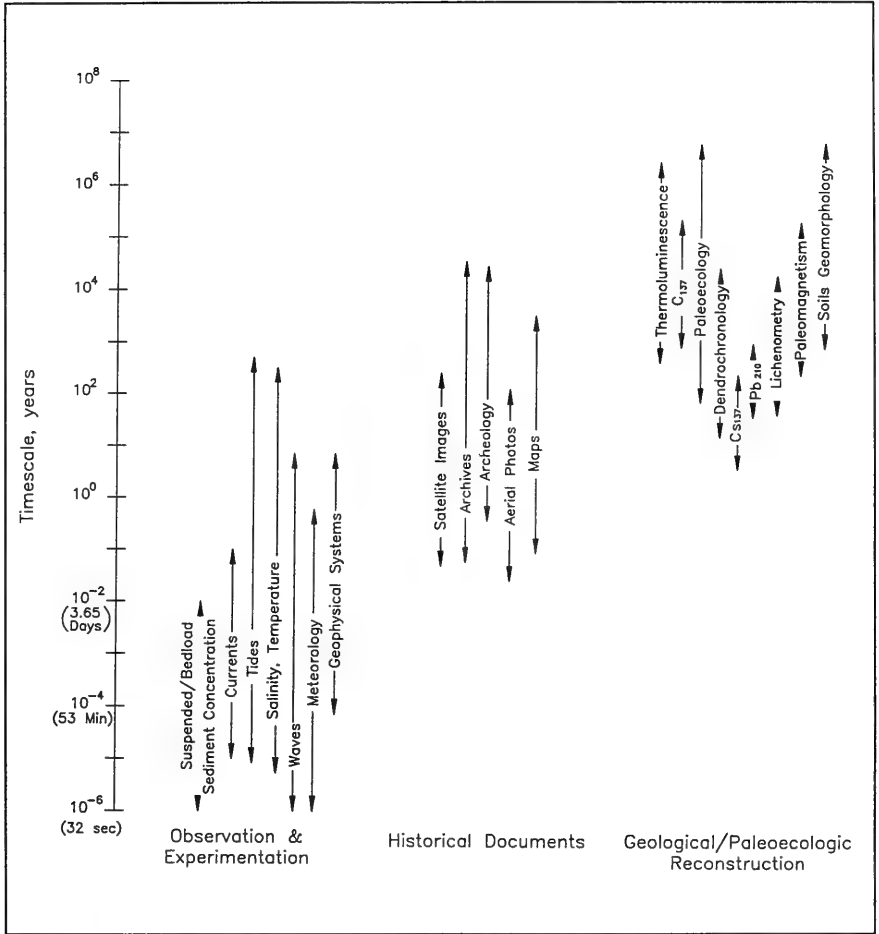

Figure 1. Some techniques for studying geomorphic changes of coasts over various time scales. Arrows indicate the approximate time span during which a particular study technique can be used

interpretations and conclusions when these are based on data covering a short time period or a small area.

Environmental and Geologic Factors Affecting Coasts

Broad classifications of morphologic type can be identified at coastlines around the world. A partial listing includes barrier, strand plain, deltaic, mud flat, volcanic, rocky, reef-fringed, and estuarine¹ coasts (Carter 1988; Mossa, Meisburger, and Morang 1992). Within each of these major groups, however, a number of distinctive environments can be distinguished when examining the coast in cross section and in plan view. Some of these environments are common to many types of coasts. Figures 2, 3, and 4 show examples of the types of environments found at coasts within some of the morphologic groups.

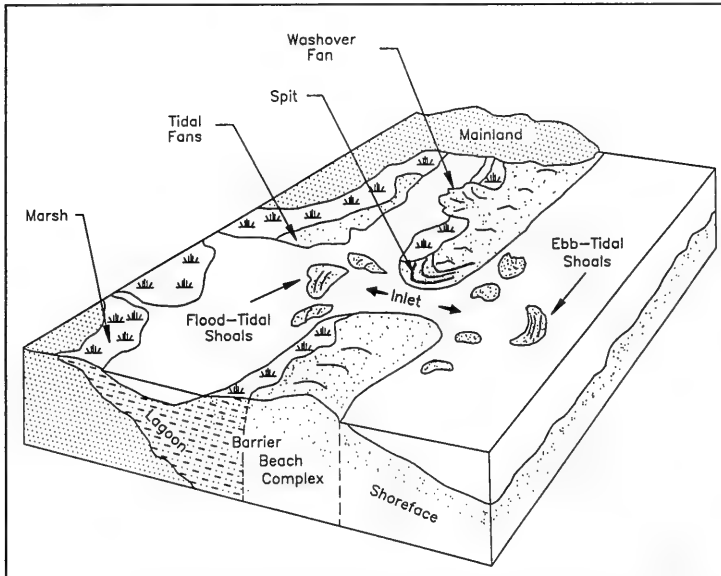

Figure 2. A three-dimensional view of some features commonly associated with a barrier island system, including the back barrier, overwash fans, and lagoons

The geomorphic variability and geologic evolution of the coast are influenced by an array of environmental factors. A partial listing of the factors that influence coasts over varying time scales includes climate, wind, and cyclonic disturbances, waves, tides, storm surges, currents, relative sea level, lithology and weathering, erosion and transportation, sediment supply, coastal

¹ Geologic terms are defined in Appendix A, "Glossary," at the end of this report.

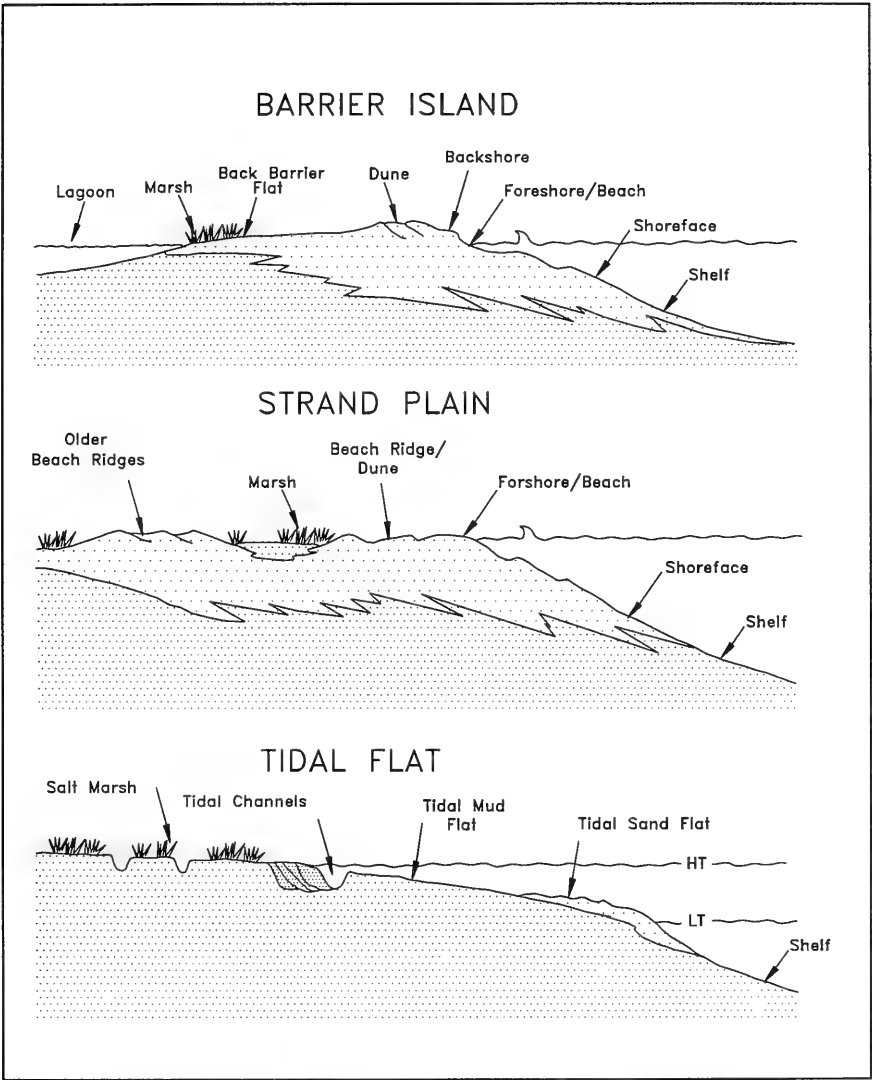

Figure 3. Surface and subsurface environments and variations of barrier islands, strand plain coasts, and tidal flats

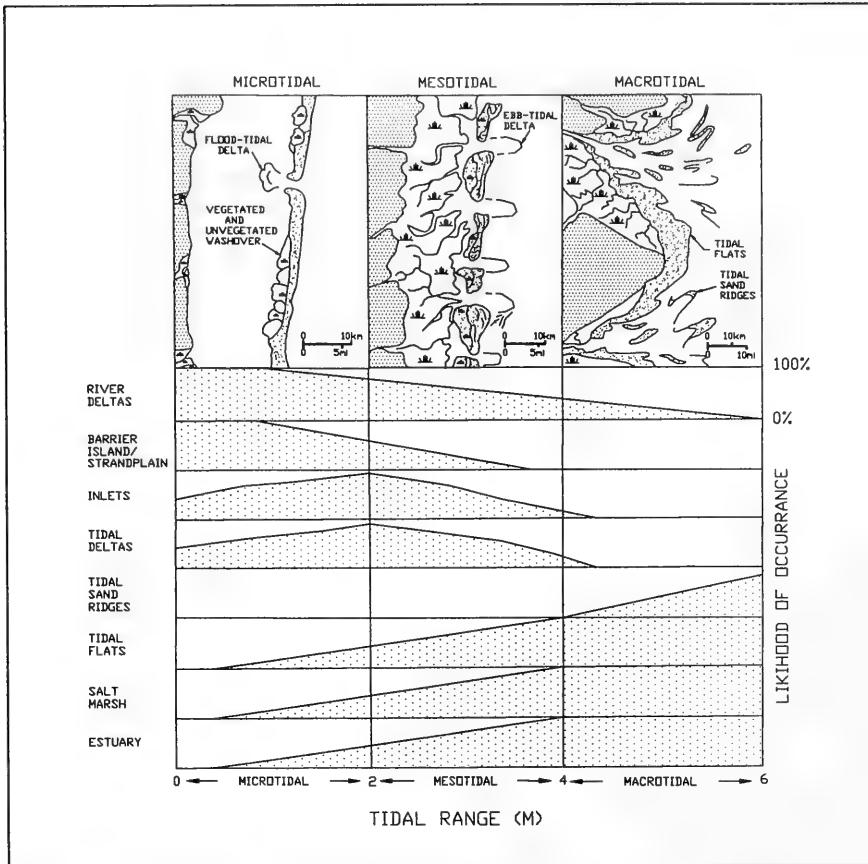

Figure 4. Morphology of microtidal, mesotidal, and macrotidal coastlines (modified from Hayes (1976)). Stipple pattern represents the likelihood that a particular land form is found along a stretch of the shoreline subject to the tide range indicated on the x-axis

materials, and human activities. The factors vary in magnitude or energy and in frequency and duration. Coastal materials may differ in structure, lithology, size, and consolidation, causing differences in their resistance to erosive forces.

Assessment of the geologic and geomorphic history of coasts is complex because a multiplicity of environmental factors affect the coast simultaneously, and coastal features can change immediately or slowly in response to these factors. Throughout the Pleistocene and Holocene periods, there have been significant fluctuations of sea level, continental tectonic uplift and subsidence,

and climatic changes, causing the zone of constant wave action to transgress or regress. Investigations of the geologic history of coasts thus may extend beyond the narrow zone of present shorelines to cover much wider areas over which coastal processes have acted during the geologic past.

Scope

This report describes technology and procedures for obtaining and analyzing evidence that can be used to interpret the geologic history of coasts. Three principal investigation time scales are discussed; namely, modern, historic, and paleoenvironmental. Some techniques used to collect and analyze data from the field, laboratory, and office can in some cases be applied to different time scale groups. For example, aerial photographs can provide information regarding both modern processes and historical changes of coasts. For this reason, this report is divided according to the differing locations where data are collected and analyzed, rather than according to the time scale of the investigation.

Chapter 1 provides an introduction and review of this report. Chapter 2 describes the coastal zone morphologies and environmental factors responsible for temporal and spatial variations of coasts, and discusses potential secondary sources of information for coastal studies. In Chapter 3, field data collection and observation are discussed. Chapter 4 summarizes recent laboratory techniques and approaches, both for analysis of field data and for controlled studies using physical models. Chapter 5 reviews a variety of approaches used for office analysis and interpretation of data from both primary and secondary sources. Chapter 6 summarizes and gives an overview of the application and availability of technology for assessing the geologic history of the coastal zone. Appendix A is a glossary of geologic terms, Appendix B is a listing of Wave Information Studies (WIS) reports, and Appendix C is a list of sources for aerial photography and other remote sensing data. Appendix D contains addresses of government agencies that produce maps, and Appendix E is a list of journals that contain articles pertaining to the geologic and geomorphic history of coasts. Appendix F is a site visit checklist for a coastal erosion study.

In reviewing technologies for assessing the geologic and geomorphic history of coasts, this report covers a breadth of information. Many of the techniques used to monitor processes and structures in the coastal zone are exceedingly complex. This report outlines some of the many errors that can occur when the inexperienced user deploys instruments or accepts without critical appraisal data from secondary sources. The text is not intended to be so pessimistic that it dissuades coastal researchers from continuing their investigations, but rather is intended to guide them to other references or to specialists where expert advice can be obtained. The reader should also consult basic references regarding coastal geology, geomorphology,

sedimentology (i.e., Boggs 1987; Komar 1976; Schwartz 1982; Pethick 1984; Davis 1985; Carter 1988), as well as references which discuss secondary sources (i.e., Chu, Lund, and Camfield 1987) and available techniques and technologies (Goudie 1981; *Shore Protection Manual* 1984; Horikawa 1988).

2 Sources of Existing Coastal Information

Literature Sources

Information pertinent to the geologic and geomorphic history of coasts can be obtained and/or interpreted from libraries, universities, and Federal, state, and local government agencies (Fulton 1981). The following provides details on some of these sources:

- a. *University and college departments and libraries.* In many instances, the collections of books, periodicals, dissertations, theses, and university faculty research project reports contain data. This especially occurs when the institutions are in coastal areas, where research is funded by Federal or state government agencies (i.e. Sea Grant), where the university has graduate programs and faculty active in research in appropriate fields, and at universities where one or more members of the faculty are coastal specialists. Major universities also have government documents repositories where Federal and state government publications are housed.
- b. *Local sources.* These are often overlooked, but can provide detailed and sometimes unique data pertinent to the locale. Such sources include the local newspaper, courthouse records, historical diaries, lighthouse records, local journals, engineering contract records, land transactions, and museums.
- c. *Government agencies.* Geologic coastal data may be available from government agencies at the Federal, state, and local level (Appendices C and D). Federal agencies with data archives include the U.S. Geological Survey (USGS), the U.S. Coast and Geodetic Survey (USCGS), the National Oceanographic and Atmospheric Agency (NOAA), the U.S. Army Corps of Engineers (USACE), (including the U.S. Army Engineer Waterways Experiment Station (WES), the Coastal Engineering Research Center (CERC), and USACE District and Division offices), the U.S. Department of

Transportation (DOT), the U.S. Environmental Protection Agency, the U.S. Fish and Wildlife Service, and the Naval Research Laboratory (NRL). At the state level, agencies with relevant coastal information include the state geological surveys (or bureaus of geology), departments of transportation, departments of environmental resources and/or water resources, and state planning departments.

- d. *Industry.* Energy (oil and gas) companies often keep records, which may be accessible to scientists, of coastal processes in conjunction with their offshore drilling operations. Construction companies have records in files on their construction projects. Environmental and engineering firms may also have data from projects that were performed for government. Some of these data are in the public domain. Environmental impact reports from nuclear power plants built in coastal areas contain extensive coastal process and geologic data.
- e. *Journals.* Most large university libraries have holdings of national and international scientific journals. Most of the scientific literature associated with the geologic history of coasts will be in the realm of geology, oceanography, marine science, physical geography, atmospheric science, earth science, and polar studies. Most research studies will be in the specific fields of coastal sedimentology, coastal geomorphology, and marine geology. A listing of pertinent journals is given in Appendix E.
- f. *Conference Proceedings.* Most large national and international conferences produce proceedings of papers presented at symposia. The conference proceedings can be obtained from university libraries. Proceedings, abstracts, etc. are also published by scientific organizations. These publications may also include announcements of symposia, grants awarded, and other announcements that may lead to environmental and geologic information.
- g. *Computerized Literature Searches.* Most major university and government agency libraries have access to computerized literature databases. The databases contain information that may be acquired by key terms, subjects, titles, and author names. Computer-operator assistance may be needed because access to the system and an understanding of its nuances are critical to a successful search. A clear and complete list of key words is important to the computer operator. It is also necessary to link terms to avoid getting extraneous/erroneous listings of information sources.

Meteorological and Climatic Data

Meteorological and climatic data are often useful for characterizing significant environmental processes and for revealing the characteristics of severe storms. Significant climatic and storm events are important in analyzing and interpreting the geologic and geomorphic history of coasts. Major storms or long-term variations in storminess strongly affect coastal morphology. This is manifested, for example, by the changes on barrier beaches associated with winds, waves, and high water levels which may cause overtopping and overwashing during storms.

Meteorological and climatic data can be compiled from secondary sources or through an original data collection program in the field using instruments and observations. As with most of the important environmental factors, most secondary information pertains to studies over historic and modern time scales. Published data are plentiful and include data from many sources throughout the world. The National Climatic Data Center and the National Hurricane Center within NOAA are important sources of meteorological and climatic data. For selected coastal sites, data collected through CERC's Littoral Environmental Observation (LEO) program may also provide helpful information. The titles of several important publications and addresses for agencies that collect meteorological and climatic data in the United States are listed in Chu, Lund, and Camfield (1987).

Wave Data

Wave data are required to characterize the process-response framework of the coastal zone. Important wave parameters include wave height, period, steepness and direction, and breaker type. Of special interest is the character of waves inside the breaker zone, where it is estimated that 50 percent of sediment movement takes place, mostly as bed load (Ingle 1966). Wave data can be: (a) collected from secondary sources; (b) estimated in the office using hindcast techniques from weather maps, shipboard observations, and littoral environment observations; or (c) measured in the field using instrumented wave gages.

Wave gage data are collected by Federal and state agencies and by private companies. For research projects that require wave data, analyzed wave statistics may be available if instrumented buoys, offshore structures, and piers are located near the study site. Published data, which are geographically spotty, include statistics from wave gages, wave hindcasting, and visual observations from shipboard or the littoral zone. The titles of several important publications and addresses for agencies that collect wave data are listed in Chu, Lund, and Camfield (1987).

Wave hindcasting is a technique widely used for estimating wave statistics by analysis of weather maps using techniques developed from theoretical considerations and empirical data (*Shore Protection Manual* 1984). The coastal scientist can use published hindcast data or may, at times, choose to compute original estimates in a study of the geologic history of coasts. Over the last several decades since wave hindcasting came into common use, many improvements have been made in the technique, and reliable information on wave climate in given areas can be obtained. Appendix B is a list of the USACE Wave Information Studies reports, which cover the Atlantic, Pacific, Gulf of Mexico, and Great Lakes coasts. Advantages of hindcasting include the long-term database associated with weather maps and the comparatively economic means of obtaining useful information. Disadvantages involve the transformation of waves into shallow water, especially in areas of complex bathymetry or near rivers.

Visual wave observations from ships at sea and from shore stations along the coasts of the United States are also published in several references. Although observations are less accurate than measured data, experienced persons can achieve reasonably accurate results and the great amount of observations available makes visual wave observation a valuable resource. Offshore, shipboard wave observations have been compiled by the U.S. Navy Oceanographic Research and Development Activity, now the Naval Research Laboratory (NRL), in the form of sea and swell charts and data summaries such as the Summary of Shipboard Meteorological Observations (SSMO). While geographic coverage by these sources is extensive, the greatest amount of observations come from shipping lanes and other areas frequented by ship traffic.

At the shore, a program sponsored by HQUSACE for data collection is the LEO program (Schneider 1981; Sherlock and Szuwalski 1987). The program, initiated in 1966, makes use of volunteer observers who make daily reports on conditions at specific sites along the coasts of the United States. Data from over 200 observation sites are available from CERC (Figure 5). As shown, LEO data not only include wave parameters, but also information on winds, currents, and some morphologic features. LEO is best applied to a specific site, and does not provide direct information on deepwater statistics. The biggest disadvantage is the subjective nature of the wave height estimates. LEO data should only be used as an indicator of long-term trends, not as a database of absolute values.

Water Level Data

Water level information is important for analysis of geologic history over modern process, historic, and geologic time scales (Figure 6). Over modern process time scales, water level changes at the coast include tides, which occur diurnally or semidiurnally, setup and setdown associated with storm

LITTORAL ENVIRONMENT OBSERVATIONS													
RECORD ALL DATA CAREFULLY AND LEGIBLY													
SITE NUMBERS 1 2 3 4 5 <input type="text"/> <input type="text"/> <input type="text"/> <input type="text"/> <input type="text"/>				YEAR 6 7 <input type="text"/> <input type="text"/>		MONTH 8 9 <input type="text"/> <input type="text"/>		DAY 10 -11 <input type="text"/> <input type="text"/>		Record time using the 24 hour system		TIME 12 13 14 15 <input type="text"/> <input type="text"/> <input type="text"/> <input type="text"/>	
WAVE PERIOD Record the time in seconds for eleven (11) wave crests to pass a stationary point. If calm record 0.				16 17 18 <input type="text"/> <input type="text"/> <input type="text"/>		BREAKER HEIGHT Record the best estimate of the average wave height to the nearest tenth of a foot.				19 20 21 <input type="text"/> <input type="text"/> <input type="text"/>			
WAVE ANGLE AT BREAKER Record to the nearest degree the direction the waves are coming from using the protractor on the reverse side. 0 if calm.				22 23 24 <input type="text"/> <input type="text"/> <input type="text"/>		WAVE TYPE 0 - Calm 3 - Surging 1 - Spilling 4 - Spill / Plunge 2 - Plunging				25 <input type="text"/>			
WIND SPEED Record wind speed to the nearest mph. If calm record 0.				26 27 <input type="text"/> <input type="text"/>		WIND DIRECTION - Direction the wind is coming from.				28 <input type="text"/>			
FORESHORE SLOPE Record foreshore slope to the nearest degree.				29 30 <input type="text"/> <input type="text"/>		WIDTH OF SURF ZONE Estimate in feet the distance from shore to breakers, if calm record 0.				31 32 33 34 <input type="text"/> <input type="text"/> <input type="text"/> <input type="text"/>			
LONGSHORE CURRENT				DYE Estimate distance in feet from shoreline to point of dye injection.				36 37 38 <input type="text"/> <input type="text"/> <input type="text"/>					
CURRENT SPEED Measure in feet the distance the dye patch is observed to move during a one (1) minute period; if no longshore movement record 0.				43 44 45 <input type="text"/> <input type="text"/> <input type="text"/>		CURRENT DIRECTION 0 No longshore movement +1 Dye moves toward right -1 Dye moves toward left				46 47 <input type="text"/> <input type="text"/>			
RIP CURRENTS If rip currents are present, indicate spacing (feet). If spacing is irregular estimate average spacing. If no rips record 0.								49 50 51 52 <input type="text"/> <input type="text"/> <input type="text"/> <input type="text"/>					
BEACH CUSPS If cusps are present, indicate spacing (feet). If spacing is irregular estimate average spacing. If no cusps record 0.								54 55 56 <input type="text"/> <input type="text"/> <input type="text"/>					
PLEASE PRINT:													
_____ SITE NAME						_____ OBSERVER							
Please Check The Form For Completeness													
REMARKS: _____ _____ _____													
CERC 113-72 8 Mar 72													
Make any additional remarks, computations or sketches on the reverse side of this form.													

Figure 5. Littoral Environmental Observation (LEO) forms used by the volunteer observers participating in the LEO program (from Schneider 1981)

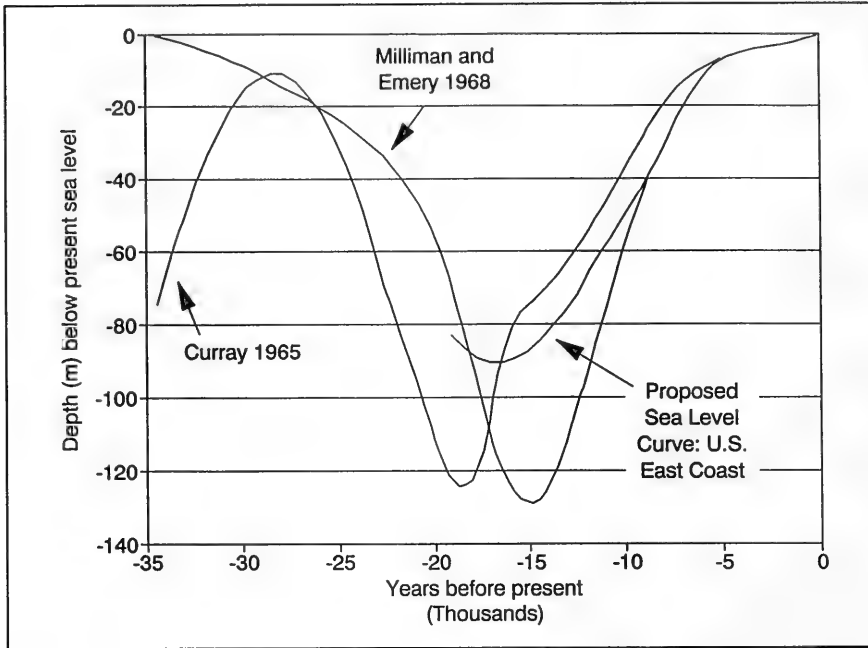

Figure 6. Late Quaternary sea level curves inferred from radiocarbon dated samples along the U.S. coastlines. Modified from Dillon and Oldale (1978)

surges, and seasonal changes in sea level, all on the order of centimeters to meters. Short-term variations, particularly those associated with storms, are important in increasing the effective wave base, allowing erosion to take place further inland.

Over historic time scales, significant water level changes may occur. Because of the complexity of this topic, it is necessary to introduce the concepts of relative and absolute sea level.

A **relative** change in water level is, by definition, a change in the elevation of the sea surface relative to some local land surface. The land, the sea, or both may have moved in **absolute** terms with respect to the earth's gravitational center. It is exceptionally difficult to determine absolute sea level changes because tide stations are located on land masses that have themselves moved vertically. For example, if both land and sea are rising at the same rate, a gage will indicate that relative sea level has been stable. Other clues, such as beach ridges or exposed beach terraces, also merely reflect relative sea level changes.

Eustatic sea level change is caused by change in the relative volumes of the world's ocean basins and the total amount of ocean water. It can be measured by recording the movement in sea-surface elevation relative to some universally adopted reference frame. This is an exceptionally difficult problem because it is essential that eustatic measurements be obtained from the use of a reference frame that is sensitive only to ocean water and ocean basin volumes. Sahagian and Holland (1991) have recently used the extensive, undeformed Russian platform to generate a Mesozoic-Cenozoic eustatic sea level curve.

Changes in water level include:

- a. Slow absolute secular sea and land level changes (time spans of thousands or millions of years). These have been caused by glacioeustatic, tectonic, climatologic, and oceanographic factors (to be discussed in more detail in Chapter 5). Sea level was about 100 to 130 m lower during the last glacial epoch (Figure 6), about 15,000 years before present. Ancient shorelines and deltas can be found at such depths along the edge of the continental shelf. Other changes of this magnitude have been recorded during other geological epochs (Payton 1977).
- b. Short-term sea level changes caused by seasonal oceanographic factors. These may be due to movements of ocean currents, runoff, melting ice, and regional atmospheric variations. Figures 7 and 8 plot monthly mean water levels from Juneau and Galveston, showing how sea level, averaged over decades, is higher during certain months. The 1985 Juneau curve (Figure 7), however, shows that during any one year, the average trend may not be followed.
- c. Land level changes. These may be slow, occurring over centuries, (for example, the compaction and dewatering of sediments in deltas) or may be abrupt, the result of volcanic activity or earthquakes. A notable example of rapid change was caused by the Great Alaskan Earthquake of 1964, when shoreline elevations ranged from 10 m uplift to 2 m downdrop (Hicks 1972; Hicks, Debaugh, and Hickman 1983). Vertical crustal displacements may be reflected in sea level curves from localized areas. Figure 9 shows how the mean sea level at Juneau is falling because of isostatic rebound of the land. In Galveston (Figure 10), a rapid rise is recorded because the land is subsiding (causing the tide gage to subside, too).

Variations in sea level, both long-term (geologic scale) and historic, do not have a direct effect on most shorelines in the same manner that waves or storm surges do. But storms have more devastating effects on a shore over time if relative sea level in the area is rising. Data on water levels can be important in predicting erosion or accretion and changes in shoreline response (Wells and Coleman 1981; Hands 1980).

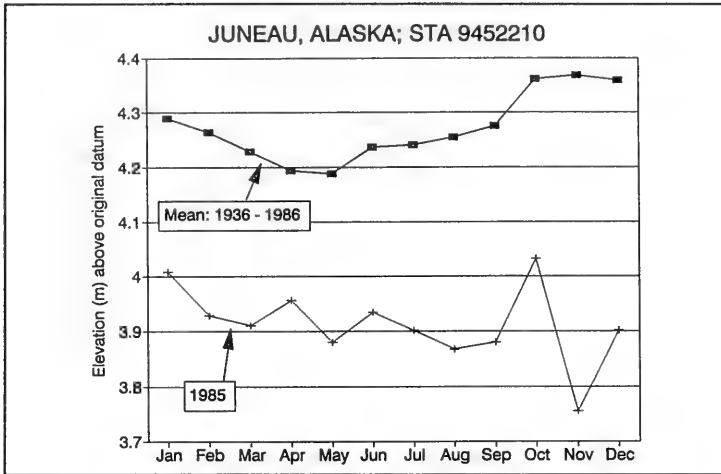

Figure 7. Monthly water level changes at Juneau, AK. High water typically occurs during October-December. Data from Lyles, Hickman, and Debaugh (1988)

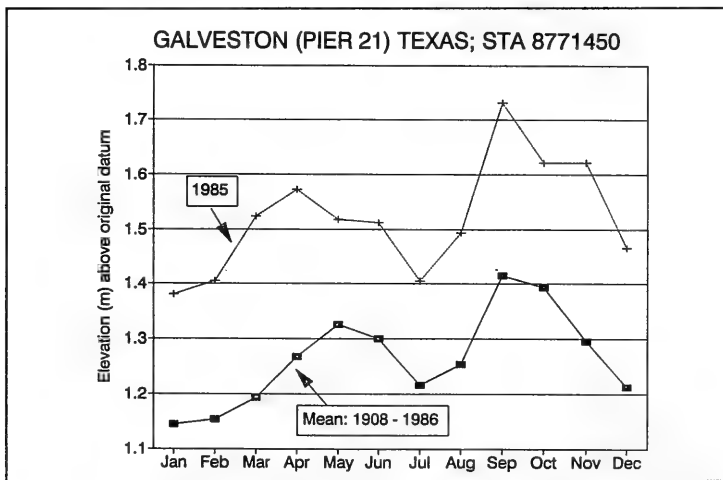

Figure 8. Monthly water level changes at Galveston, TX. High water occurs twice per year: April and September - November. Data from Lyles, Hickman, and Debaugh (1988)

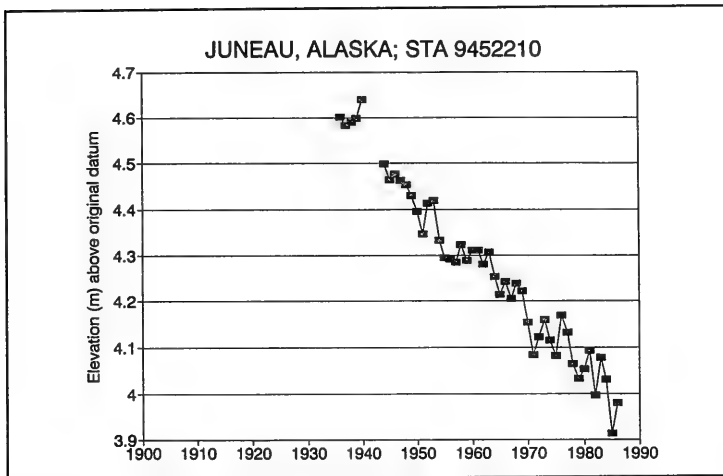

Figure 9. Yearly mean sea level changes at Juneau, AK, from 1936-1986. The overall fall in sea level shows the effects of isostatic rebound. Data from Lyles, Hickman, and Debaugh (1988)

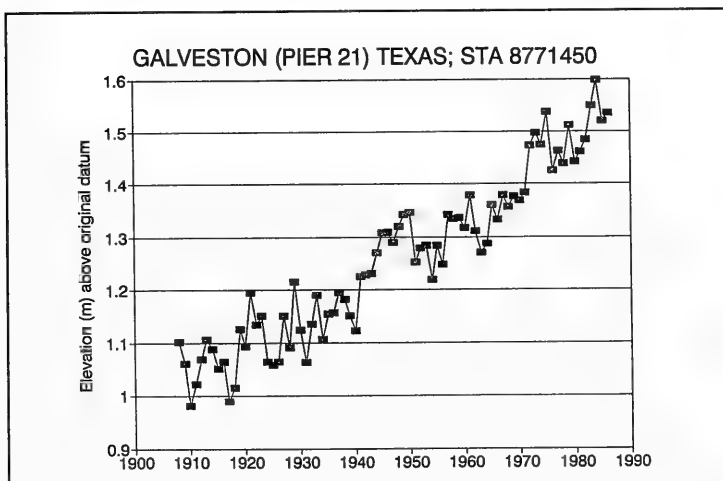

Figure 10. Yearly mean sea level changes at Galveston, TX, from 1908-1986. Subsidence of the land around Galveston may be caused by groundwater withdrawal and compaction. Data from Lyles, Hickman, and Debaugh (1988)

Many sources of water level and current data are available. The National Ocean Survey of the National Oceanic and Atmospheric Administration is responsible for monitoring sea level variations at 115 station locations nationwide (Hicks 1972). Coastal Corps of Engineers District offices collect tidal elevation data at additional locations. Daily readings are published in reports that are titled "Stages and Discharges of the (location of District office) District." Predicted water levels and tidal current information for each day can be obtained from the annual "Tide Tables: High and Low Water Predictions" and "Tidal Current Tables" published by the National Ocean Service (NOS). A convenient way to obtain daily tides is a personal computer (PC) program called TIDEMASTER.¹ Background information concerning tidal datums and tide stations can be found in NOS publications titled "Index of Tide Stations: United States of America and Miscellaneous Other Stations," and "National Ocean Service Products and Services Handbook."

An important consideration for evaluating water-level information or for constructing and examining shoreline change maps is the level and type of datum used. Because water levels are not constant over space and over time, datums must be established from which depth and elevation changes can be referenced. Common water level datums include mean lower low water (mllw), mean low water (mlw), mean sea level (msl), mean tide level (mtl), mean high water (mhw), and mean higher high water (mhhw) (Figure 11 and Table 1). Of these, msl is most often used and is computed as the arithmetic means of hourly water elevations observed over a specific 19-year cycle. Some areas of the United States have established regional datums, based on combinations of other datums, or based on local measurements of water level over different periods. Often these water level datums are cited in reference to fixed surfaces for land surveys; namely, the National Geodetic Vertical Datum (NGVD) developed in 1929, and the North American Datum of 1983 (NAD 83). Specific definitions of the various datums and the relationship between major water-level datums and geodetic datums are listed in references from the NOS and HQUSACE (1989). Note that the land benchmarks, which represent the various datums, can move because of the factors described earlier. Therefore, datums must be corrected and updated periodically.

Low water reference datums used on the Great Lakes and their connecting waterways are currently based on the International Great Lakes Datum (IGLD) 1985. This datum, which was established and revised under the auspices of the Coordinating Committee on Great Lakes Basic Hydraulic and Hydrologic Data, was implemented in January 1992, and replaces IGLD 1955. The main difference between IGLD 1955 and IGLD 1985 is corrections in the elevations assigned to water levels (Table 2). This is a result of benchmark elevation changes due to adjustments for crustal movements, more accurate measurement of elevation differences, a new reference zero point location, and an

¹ Commercially available from Zephyr Services, 1900 Murray Ave., Pittsburgh, PA 15217. Other similar programs exist, some of which are updated quarterly or yearly.

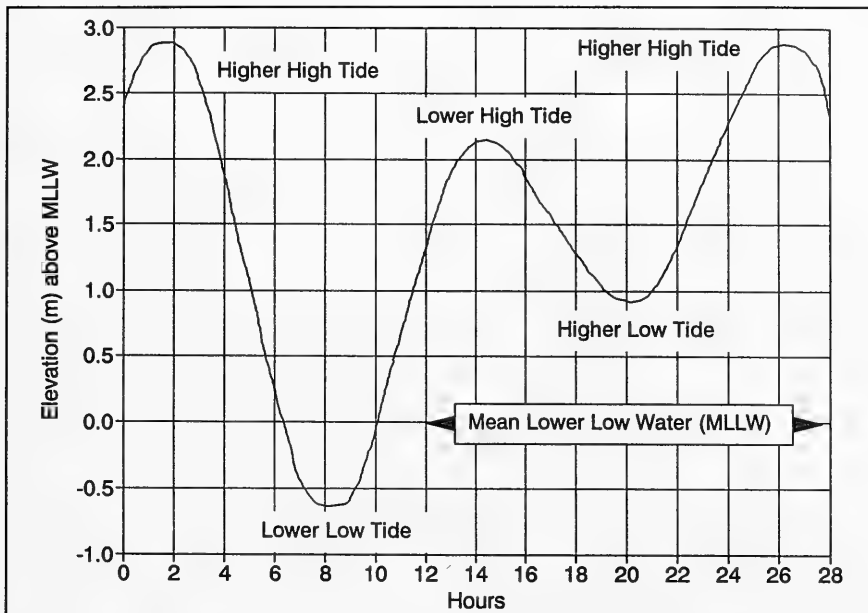

Figure 11. Typical tide curve for Oregon coast. Based on 6 years of observations in Yaquina Bay. By definition, mllw is zero

expanded geodetic network. The reference zero point of IGLD 1985 is located at Rimouski, Quebec (Figure 12). The new 1985 datum establishes a set of elevations consistent with one another for surveys taken within the time span 1982 - 1988. IGLD 1985 is referred to the North American Vertical Datum (NAVD) 1988. Note that the IGLD's are not parallel to NGVD 29 or NAVD 1988 because the Great Lakes datums are dynamic or geopotential heights and are designed to best represent the hydraulic structure of the lakes and connecting waterways (Great Lakes Commission 1986, HQUSACE 1991).

Geologic and Sediment Data

It is often important in studies of the geologic and geomorphic history of coasts to evaluate existing geologic and sediment data. This type of information is dispersed among numerous agencies and sources and includes a variety of materials such as geologic maps, soil surveys, highway borings, and process data such as the concentrations and fluxes of suspended sediment from nearby rivers. Differences in geology and soil type may provide clues toward understanding erosion and accretion patterns. Geologic and sedimentologic

Table 1
Tidal Datums and Definitions, Yaquina Bay, Oregon

Tide Staff (m)	Datum and Definition
4.42	Extreme high tide. The highest projected tide that can occur. It is the sum of the highest predicted tide and the highest recorded storm surge. Such an event would be expected to have a very long recurrence interval. In some locations, the effect of a rain-induced freshet must also be taken into consideration. The extreme high tide level is used for the design of harbor structures.
3.85	Highest measured tide. The highest tide actually observed on the tide staff.
3.14	Highest predicted tide. Highest tide predicted by the Tide Tables.
2.55	Mean higher high water. The average height of the higher high tides observed over a specific time interval. The intervals are related to the moon's many cycles, which range from 28 days to 18.6 years. The time length chosen depends upon the refinement required. The datum plane of mhhw is used on NOS charts to reference rocks awash and navigational clearances.
2.32	Mean high water. The average of all observed high tides. The average is of both the higher high and of the lower high tide recorded each day over a specific time period. The datum of mhw is the boundary between upland and the tideland. It is used on navigational charts to reference topographic features.
1.40	Mean tide level. Also called half-tide level. A level midway between mhw and mlw. The difference between mean tide level and local mean and sea level reflects the asymmetry between local high and low tides.
1.37	Local mean sea level. The average height of the water surface for all stages of the tide at a particular observation point. The level is usually determined from hourly height readings.
1.25	Mean sea level. A datum based upon observations taken over a number of years at various tide stations along the west coast of the United States and Canada. It is officially known as the <i>Sea Level Datum of 1929, 1947 adj.</i> The msl is the reference for elevations on USGS quadrangles. The difference between msl and local msl reflects numerous factors ranging from the location of the tide staff within an estuary to global weather patterns.
0.47	Mean low water. The average of all observed low tides. The average is of both the lower low and of the higher low tides recorded each day over a specific time period. The datum of mlw is the boundary line between tideland and submerged land.
0.00	Mean lower low water. The average height of the lower low tides observed over a specific time interval. The datum plane is used on Pacific coast nautical charts to reference soundings.
-.88	Lowest predicted tide. The lowest tide predicted by the Tide Tables.
-.96	Lowest measured tide. The lowest tide actually observed on the tide staff.
1.07	Extreme low tide. The lowest estimated tide that can occur. Used by navigational and harbor interests.

Table 2
Low Water (chart) Datum for IGLD 1955 and IGLD 1985

Low Water Datum in Meters		
Location	IGLD 55	IGLD 85
Lake Superior	182.9	183.2
Lake Michigan	175.8	176.0
Lake Huron	175.8	176.0
Lake St. Clair	174.2	174.4
Lake Erie	173.3	173.5
Lake Ontario	74.0	74.2
Lake St. Lawrence at Long Sault Dam, Ontario	72.4	72.5
Lake St. Francis at Summerstown, Ontario	46.1	46.2
Lake St. Louis at Pointe Claire, Quebec	20.3	20.4
Montreal Harbour at Jetty Number 1	5.5	5.6

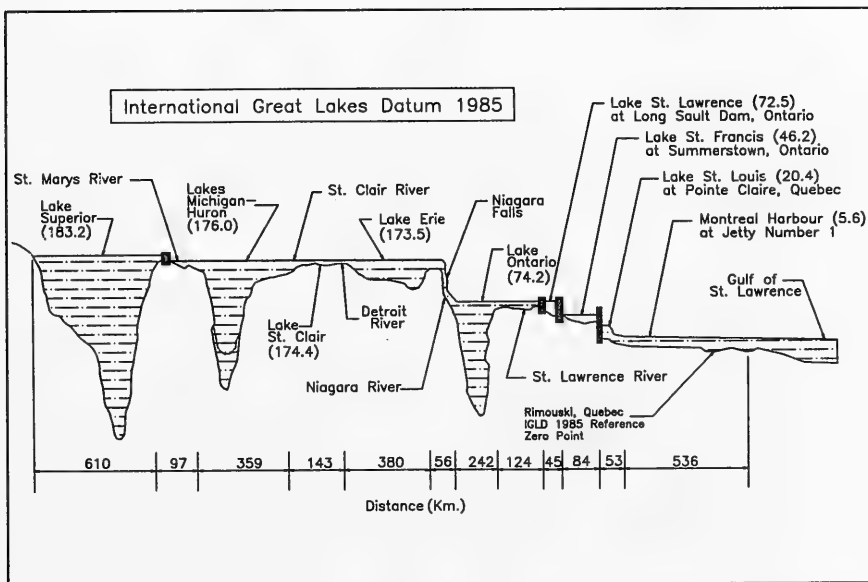

Figure 12. The reference zero point for IGLD 1985 at Rimouski, Quebec is shown in its vertical and horizontal relationship to the Great Lakes-St. Lawrence River System. Low-water datums for the lakes are shown in meters

data are often useful for characterizing significant environmental processes and responses, such as the effects of severe storms on coastlines.

Information from secondary sources may be pertinent to studies from modern to paleoenvironmental time scales. Although some geologic data can be compiled from secondary sources, generally it is necessary to conduct original data collection programs using field instruments and observations. This must be followed up by laboratory and office analyses and interpretation. Published data are available from agencies such as the USGS, the U.S. Soil Conservation Service, the American Geological Institute, and CERC. Additional sources of geologic and sedimentologic data in the United States are listed in Chu, Lund, and Camfield (1987).

Sources of Aerial Photography

Historic and recent aerial photographs provide invaluable data for the interpretation of geologic and geomorphic history. The photographs can be obtained from Federal and state government agencies such as the USGS, the U.S. Department of Agriculture, the EROS Data Center, and others listed in Appendices C and D. Stereographic pairs with overlap of 60 percent are often available, allowing very detailed information to be obtained using photogrammetric techniques. Temporal coverage for the United States is available from the 1930's to present for most locations. The types of analysis and interpretation that can be performed depend in part on the scale of the photographs, the resolution, and the percentage of cloud cover. The effects of major events can be documented by aerial photography because the photographic equipment and airplane can be rapidly mobilized. By such means, the capability exists for extensive coverage in a short time and for surveillance of areas that are not readily accessible from the ground.

For modern process studies, a series of aerial photographs provides significant data for examining a variety of problems. Information pertinent to environmental mapping and classification such as the nature of coastal landforms and materials, the presence of engineering structures, the effects of recent storms, the locations of rip currents, the character of wave shoaling, and the growth of spits and other coastal features can be examined on aerial photographs. For the assessment of some morphologic features, photogrammetric techniques may be helpful. If possible, it is generally considered preferable to arrange flights or obtain photography acquired during low tide, so that nearshore features will be exposed or partly visible through the water.

For studies over historical time scales, multiple time series of aerial photographs are required. Historical photography and maps are an integral component of shoreline change assessments. Water level and, therefore, shoreline locations show great variation according to when aerial photographic missions were flown. Therefore, the coastal scientist should account for such

variations as potential sources of error in making or interpreting shoreline change maps. Chapter 5 contains a more detailed discussion of aerial photograph analysis.

Satellite Remotely Sensed Data

Satellite data are available from U.S. agencies, the French Systeme Pour l'Observation de la Terre (SPOT) satellite data network, and from Soviet coverage¹. In most instances, the data can be purchased either as photographic copy or as digital data tapes for use in computer applications. Imagery and digital data may assist in understanding large-scale phenomena, especially processes that are indicators of geologic conditions and surface dynamics. Agencies that collect and distribute satellite data are listed in Appendix C.

Satellite data are especially useful for assessing large-scale changes in the coastal zone. In the vicinity of deltas, estuaries, and other sediment-laden locations, the determination of spatial patterns of suspended sediment concentration can be facilitated with remote sensing (Figure 13). In shallow-water depths of non-turbid water bodies, some features of the offshore bottom, including the crests of submarine bars and shoals, can be imaged. On a relatively crude level, satellites may assist in monitoring tidal changes, particularly where the land-sea boundary changes several hundreds of meters. The spatial extent of tidal flows may also be determined using thermal infrared data, which can be helpful in distinguishing temperature differences of ebb and flood flows and freshwater discharges in estuaries (Figure 14). In deeper waters, satellites can also provide data on ocean currents and circulation (Barrick, Evans, and Weber 1977). Aircraft-mounted radar data also show considerable promise in the analysis of sea state.

The Landsat satellite program was developed by the National Aeronautics and Space Administration with the cooperation of the U.S. Department of the Interior. When it began in 1972, it was primarily designed as an experimental system to test the feasibility of collecting earth resources data from unmanned satellites. Landsat satellites have used a variety of sensors with different wavelength sensitivity characteristics, ranging from the visible (green) to the thermal infrared with a maximum wavelength of 12 micrometers (μm). Figure 15 shows bandwidths and spatial resolution of various satellite sensors. Of the five Landsat satellites, only Landsat-4 and Landsat-5 are currently in orbit. Both are equipped with the MSS (multispectral scanner), which has a resolution of 82 m in four visible and near-infrared bands, and the thematic mapper, which has a resolution of 30 m in six visible and near- and

¹ Russian Sojuzkarta satellite photography data are available from Spot Image Corporation (Appendix C). Almaz synthetic aperture radar data are available from Hughes STX Corporation.



Figure 13. SPOT satellite image, Atchafalaya Bay, LA. Suspended sediment from runoff is clearly visible. Data processed by the Earthscan Laboratory, School of Geosciences, Louisiana State University, Baton Rouge, LA

mid-infrared bands and a resolution of 120 m in one thermal infrared band (10.4-12.5 μ).

SPOT is a commercial satellite program. The first satellite, which was sponsored primarily by the French government, was launched in 1986. The SPOT-1 satellite has two identical sensors known as HRV (high-resolution-visible) imaging systems. Each HRV can function in a 10-m resolution panchromatic mode with one wide visible band, or a 20-m-resolution multi-spectral (visible and near infrared) mode with three bands (Figure 13).

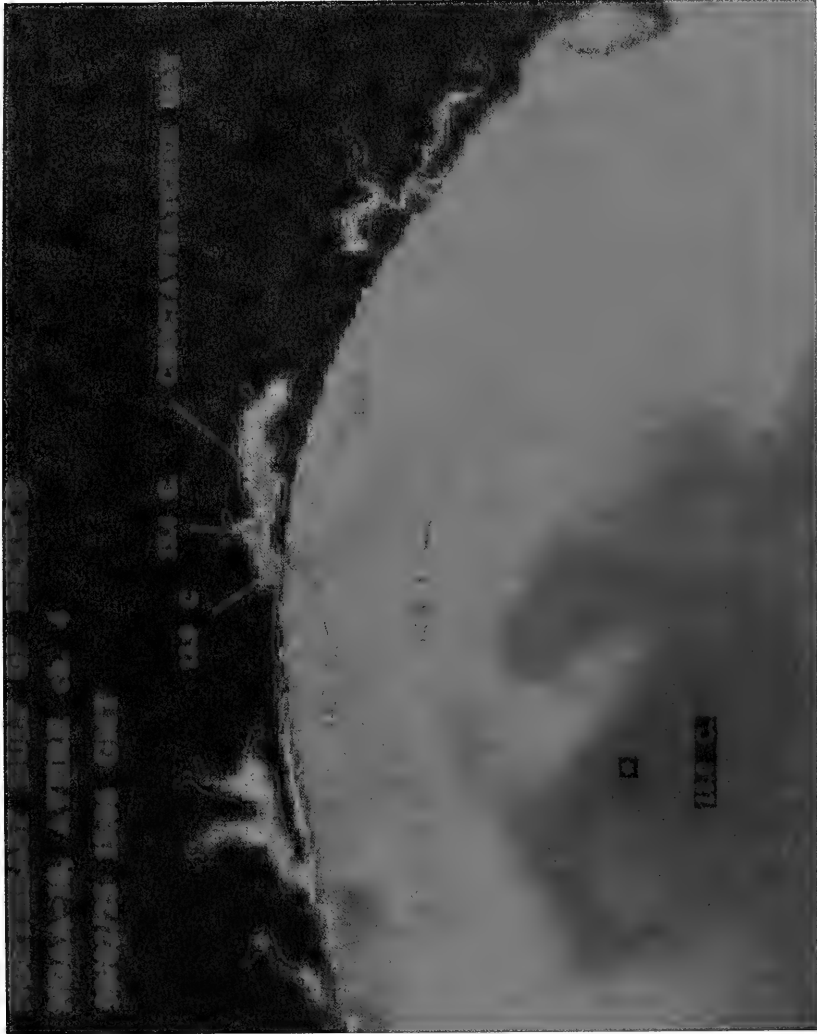

Figure 14. Northeast Gulf of Mexico, February 1990. NOAA 10 satellite, AVHRR Channel 4. This false color image depicts dramatic variations in water temperature. The Loop Current waters in the lower part of the image are over 18° C. Plumes of much colder water are emerging from Choctawhatchee and Pensacola Bays in response to the passage of a winter cold front, which caused nearshore water level to drop about 2 ft. Satellite data captured by the Earthscan Laboratory, School of Geosciences, Louisiana State University, Baton Rouge, LA. Image processed by the author (Morang) at LSU

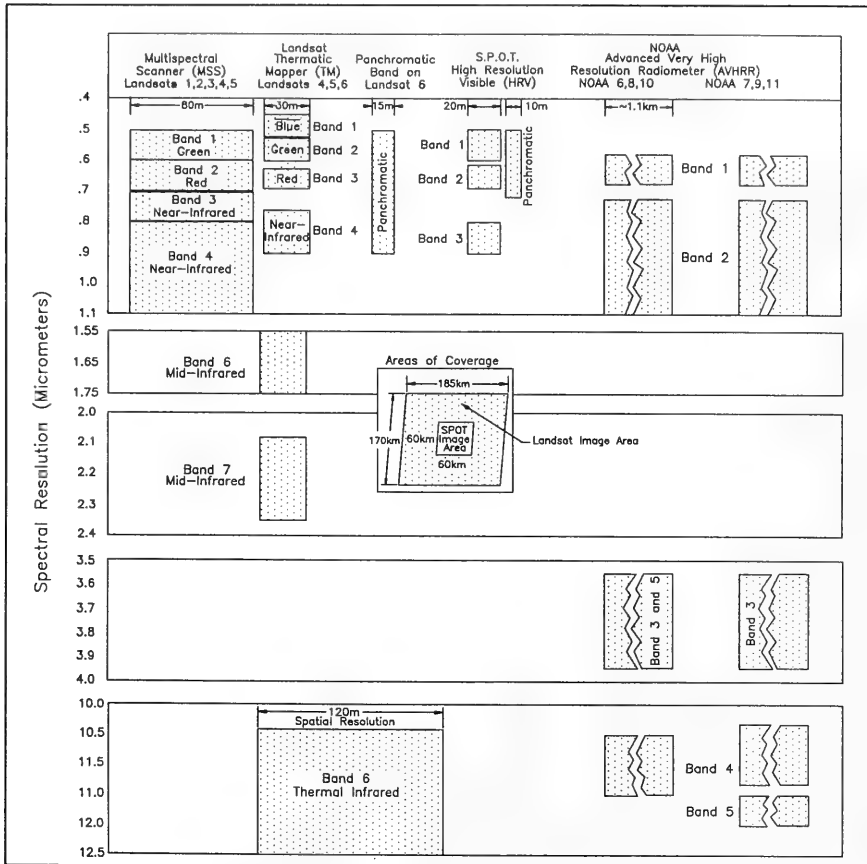

Figure 15. Spectral resolution and approximate spatial resolution of sensors on LANDSAT, SPOT, and NOAA satellites (from Earth Observation Satellite Company literature and Huh and Leibowitz (1986))

Several generations of satellites have flown in the NOAA series. The most recent ones contain the Advanced Very High Resolution Radiometer (AVHRR). This provides increased aerial coverage but at much coarser resolution than the Landsat or SPOT satellites. Figure 14 is an example of an AVHRR Channel 4 image of the northeast Gulf of Mexico. More information on the wide variety of satellites can be found in textbooks on remote sensing (i.e. Colwell 1983; Lillesand and Kiefer 1987; Richards 1986; Sabins 1987; Siegal and Gillespie 1980; Stewart 1985).

Aircraft-mounted scanners, including thermal sensors and radar and microwave systems may also have applications in coastal studies. LIDAR (light

detection and ranging), SLAR (side-looking airborne radar), SAR (synthetic aperture radar), SIR (shuttle imaging radar), and passive microwave systems have applications including mapping of bottom contours of coastal waters. Some of these systems, such as LIDAR, are capable of accurate profiling of water depths by using transmission and reflection from a pulsed coherent laser light beneath an aircraft. In operation, a strongly reflected return is recorded from the water surface, followed closely by a weaker return from the bottom of the water body.

Topographic and Bathymetric Data

Topographic and bathymetric maps are available from the USGS, many Corps of Engineer District Offices, and the USCGS. USGS topographic maps are generally revised every 20 to 30 years; sometimes more often in areas determined to be of high priority. Nevertheless, the maps may be outdated for some studies because of the ephemeral nature of many coastlines. The USGS quadrangles are the 7.5 minute series (scale 1:24,000) and the 15 minute series (scale 1:62,500). The resolution of these maps is typically inadequate to provide details of surface features, but may be sufficient for examining large landforms and pronounced changes, particularly over long periods.

Hydrographic survey data are available from the NOS and its predecessor, the USCGS. Archives of all past surveys of these agencies are available from NOS, a division within NOAA. Much of this data can be obtained in the form of preliminary plots that are of larger scale and contain more soundings and bottom notations than the published charts made from them.

Bathymetric survey maps are sometimes out of date because geomorphic changes in many submarine areas occur rapidly. On some navigation charts, the bathymetry may be more than 50 years old and the marked depths may be quite different from actual depths. The greatest changes can be areas of strong current activity, of strong storm activity, of submarine mass movement, and of dredging near ship channels. The user must also be aware of changes in the datum used in different maps.

Shoreline Change Maps

Shoreline changes may be interpreted from navigation maps, topographic maps, aerial photographs, and property records. In some areas, maps showing shoreline changes and land loss may have been produced by state and Federal agencies, universities, or engineering firms. However, the user should be aware of potential sources of error that may not have been adequately corrected when these maps were prepared.

Shoreline and coastal change maps that are constructed from historic maps and photographs are subject to numerous sources of error. For example, maps may not have common datums, may have different scales, may have variable accuracy due to age or loss of accuracy in publication procedures, and may be based on different projections, which in turn cause geometric distortions. Ideally, shoreline change maps constructed from aerial photographs should be corrected for distortions caused by pitch, tilt, and yaw of the aircraft. Difficulties in identifying common points over time, problems in rectifying scale, and distortions near margins and corners are common. Additional problems include the unavailability of photographs of the desired vintage, scale, clarity, or resolution. Haze, fog, and cloud cover may obscure ground features. Finally, the water level at the time that the photographs were taken can greatly influence the position of the shorelines.

3 Field Data Collection and Observation

In order to apply appropriate technologies to a field study, the coastal scientist should know something about the nature of the problem and the expected outcome. For example, if a community is being threatened by erosion, measurements of processes, topography, and bathymetry may be in order to determine storm-induced and long-term erosion trends. Also, studies of historical data may be required to determine the rates and spatial variability of shoreline change over time. Studies involving stratigraphy may be required, especially if finding local sources of borrow material for beach nourishment is necessary. Design of a research study must include thorough planning of objectives and sampling strategies, given temporal, logistical, and budgetary constraints. Much time and effort can be wasted during a field study if the research objectives are not well-defined and the sampling plan is inappropriate.

Secondary sources of coastal data often cannot satisfy all of the specific purposes or objectives of a study whose purpose is to assess the geologic and geomorphic history of coasts. However, it is likely that secondary sources can provide useful supplemental information. In addition, these sources can be helpful in designing a field data collection program.

If a field collection program is to be undertaken, the type of data to be acquired depends upon study objectives, parameters required, area to be studied, funding available, refinement of data (resolution) and site conditions. Thorough background work should be conducted and secondary sources consulted before the field visit. While in the field, either for reconnaissance or detailed sampling, relevant data and information should be meticulously recorded in water-resistant field books. Details can also be recorded on a tape recorder. Photographs serve as valuable records of field conditions, sampling equipment, and procedures. Increasingly, video recorders are being used during field reconnaissance.

The type of work conducted in the field may fall into several categories. It may range from a simple visual site inspection to a detailed collection of process measurements, sediment samples, stratigraphic samples, topographic and bathymetric data, and geophysical data. Studies may include exploring

the acting forces, rates of activity, interactions of forces and sediments, and variations in activity over time. If the field work will involve extensive data collection, a preliminary site visit is highly recommended in order to help determine sampling considerations and to develop a sampling plan.

Spatial and temporal aspects of site inspection are important considerations. The spatial dimensions of the sampling plan should have adequate longshore and cross-shore extent, and an adequate grid or sample spacing with which to meet study objectives. Temporal considerations include the frequency of sampling and the duration over which samples will be collected. Sampling frequency and duration are most important in modern process studies, such as monitoring the topographic and bathymetric changes associated with storms. Studies of paleoenvironmental or geologic time scales usually do not require repetitive visits, but thorough spatial sampling is critical.

Information collected from the field observation and measurements can be used in analysis and numerical models. A conceptual model is often formulated while the initial observations are being conducted. The conceptual model is in essence a perception or understanding of the situation. The perception may be validated by the application of empirical relationships. Further verification of the observed field relationships is obtained by the application of physical or mathematical laws. The quantifying of parameters and the use of these parameters in testing the physical or mathematical relationships may support or negate the interpretation. Additional observations may be required to test a wider variety of conditions, and conceptual models may need to be revised depending on the results of the study.

Site Inspection and Local Resources

A general site inspection can provide insights toward identifying significant research problems at a study area, in verifying and enhancing data from aerial photographs and remote sensing sources, and in developing sampling strategies for more rigorous types of field work. Even for a brief site visit, thorough preparation is strongly recommended. Preparation should include reviewing the pertinent geologic, oceanographic, and engineering literature, compiling maps and photographs, and understanding the scope of the problem or situation. If one individual cannot achieve all these objectives, it is necessary that a team conduct the preliminary project planning. The field inspection should include observations by all members if at all possible.

The duration of the field examination must be sufficient to assess the major objectives of the study. Local residents, existing data records, and field monitoring equipment may need to be used. A site inspection should include observation of marine forces and processes, assessment of geomorphic indicators, visits to neighboring sites, and interviews with residents and other

local or knowledgeable individuals. Questions to be asked might include what, why, when, where, and how come? Why does this section of the shore look as it does? How do humans influence the local environment? Is the problem geologic (natural) or man-made? Do catastrophic events, such as hurricanes, appear to have much impact on the region? A checklist of data to be collected at a site visit for a coastal erosion study is presented in Appendix F.

Photographs and Time Sequences

Photography is often an important tool for initial reconnaissance work as well as for more detailed assessments of the study area. One special application of cameras involves the use of time-lapse or time-interval photography. Time-lapse and time-interval photography may be helpful in studies of geomorphic variability to observe shoreline conditions, sand transport (Cook and Gorsline 1972), and wave characteristics. If the camera is set to record short-term processes, relatively frequent photographs are typically obtained. If historic ground photographs are available, additional pictures can be acquired from the same perspective. Changes in an area over time, applicable to both short- and long-term studies, can also be recorded with video photography. It is important that the following pertinent photographic information be recorded in a field log:

- Date.
- Time.
- Camera location.
- Direction of each photograph.
- Prominent landmarks, if any.

Wave Measurements and Observations

It is often relevant in studies of historic and process time scales to obtain data regarding wave conditions at the site. Instrumented wave gages typically provide the most accurate wave data. Unfortunately, wave gages are expensive to purchase, deploy, maintain, and analyze. Often, they are operated for a short term to validate data collected by visual observation or hindcasting methods. Multiple gages, set across the shore zone in shallow and deep water, can be used to determine the accuracy of wave transformation calculations for a specific locale.

Types of wave gages

Wave gages can be separated into two general groups: directional and non-directional. In general, directional gages and gage arrays are more expensive to build, deploy, and maintain than non-directional gages. Nevertheless, for some applications, directional instruments are vital because the directional distribution of wave energy is an important parameter in many applications, such as sediment transport analysis and calculation of wave transformation. Wave gages can be installed in buoys, placed directly on the sea or lake bottom, or mounted on existing structures, such as piers, jetties, or offshore platforms.

Of the non-directional wave gages, buoy-mounted systems such as the Datawell Waverider are the most expensive to purchase initially but are accurate and relatively easy to deploy and maintain. Data are usually transmitted by radio between the buoy and an onshore receiver and recorder. Bottom-mounted pressure gages measure water level changes by sensing pressure variations with the passage of each wave. The gages are either self-recording or are connected to onshore recording devices with cables. Bottom-mounted gages must be maintained by divers, unless the mount can be retrieved by hoisting from a workboat. Internal-recording gages usually need more frequent maintenance because the data tapes must be changed or the internal memory downloaded. Advantages and disadvantages of self-contained and cable-telemetered gages are listed in Table 3. Structure-mounted wave gages are the most economical and most accessible of the non-directional gages, although their placement is confined to locations where structures exist. The recording devices and transmitters can be safely mounted above water level on the structure.

Directional wave gages are also mounted in buoys or on the sea floor (Figure 16). Arrays of non-directional gages can be used for directional wave analyses. Directional buoy-type wave gages are often designed to collect other parameters such as meteorology. The buoys are relatively easy to deploy, but they cost more initially and continuing maintenance is required.

Placement of wave gages

The siting of wave gages along the coast depends on the goals of the monitoring project, funds and time available, environmental hazards, and availability of previously collected data. The user must usually compromise between collecting large amounts of data for a short, intensive experiment, and maintaining the gages at sea for a longer period in order to try to observe seasonal changes. There are no firm guidelines for placing gages at a site, and each project is unique. A priori knowledge of the site or practical considerations may dictate gage placement. Table 4 summarizes some suggested practices based on budget and study goals. Suggestions on data sampling intervals are discussed in Chapter 5.

Table 3
Self-Contained and Cable-Telemetry Wave Gages; Advantages and Disadvantages

I. Self-contained gages

A. Advantages

1. Deployment is often simple because compact instrument can be handled by a small dive team.
2. Gage can be easily attached to piles, structural members, or tripods.
3. Field equipment can be carried by airplane to remote sites.
4. Gage will continue to function in severe storms as long as the mount survives.

B. Disadvantages

1. Gage must be periodically recovered to retrieve data or replace data tapes.
2. Data collection time is limited by the capacity of the internal memory or data tapes. Researcher must compromise between sampling density and length of time the gage can be gathering data between scheduled maintenance visits.
3. Battery capacity may limit the deployment time.
4. If bad weather forces delay of scheduled maintenance, gage may reach the limit of its storage capacity. This will result in unsampled intervals.
5. While under water, gage's performance cannot be monitored. If it fails electronically or leaks, data are usually lost forever.
6. Gage may be struck by anchors or fishing vessels. The resulting damage or total loss may not be detected until the next maintenance visit.

C. Notes

1. Data compression techniques and advances in low-energy memory have dramatically increased the storage capacity of underwater instruments. Some can remain onsite as long as 12 months.
2. If a gage floods, data from electronic memory systems are usually irretrievably lost. On the other hand, a wet data tape can sometimes be saved by flushing with fresh water and carefully drying.
3. Onboard data processing can extend deployment times by reducing the need to store raw data.

II. Data transmission by cable.

A. Advantages

1. Data can be continuously monitored. If a failure is detected (by human analysts or error-checking computer programs), a repair team can be sent to the site immediately.
2. Because of the ability to monitor the gage's performance, infrequent inspection visits may be adequate to maintain systems.
3. Frequency and density of sampling are only limited by the storage capacity of the shore-based computers.
4. Gage can be reprogrammed in situ to change sampling program.
5. Electrical energy is supplied from shore.

B. Disadvantages

1. Cable to shore is vulnerable to damage from anchors or fishing vessels.
2. Shore station may be damaged in severe storms, resulting in loss of valuable storm data.
3. Shore station and data cable are vulnerable to vandalism.
4. Backup power supply necessary in case of blackouts.
5. Installation of cable can be difficult, especially in harbors and across rough surf zones.
6. Installation often requires a major field effort, with vehicles on beach and one or two boats. Heavy cable must be carried to the site.
7. Cable eventually deteriorates in the field and must be replaced.
8. Cable may have to be removed after experiment has ended.

C. Notes

1. Some cable-based gages have internal memory and batteries so that they can continue to collect data even if cable is severed.
2. Ability to constantly monitor gage's performance is a major advantage in conducting field experiments.

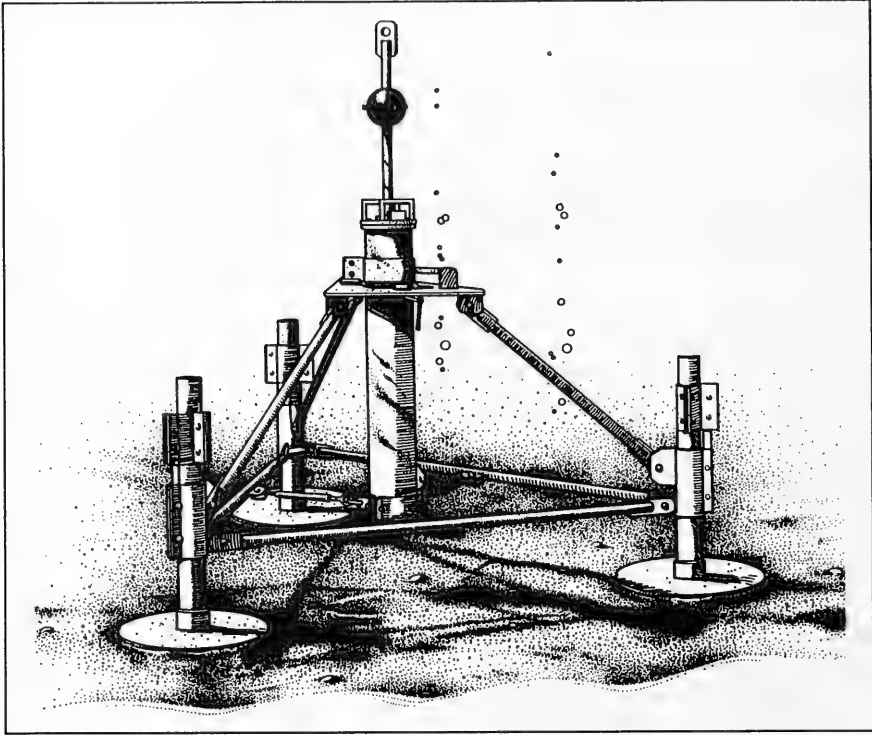

Figure 16. Bottom-mounted Sea Data™ 635-12 directional wave gage mounted in tripod using railroad wheels as corner weights

Seismic wave gage

Wave estimates based on microseismic measurements are an alternative means to obtain wave data in high-energy environments. Microseisms are very small ground motions that can be detected by seismographs within a few kilometres of the coast. It is generally accepted that microseisms are caused by ocean waves and that the amplitudes and periods of the motions correspond to the regional wave climate. Comparisons of seismic wave gages in Oregon with in situ gages have been favorable (Howell and Rhee 1990; Thompson, Howell, and Smith 1985). The seismic system has inherent limitations, but deficiencies in wave period estimates can probably be solved with more sophisticated processing. Use of a seismometer for wave purposes is a long-term commitment, requiring time to calibrate and compare the data. The advantage of a seismograph is that it can be placed on land in a protected building.

Table 4
Wave Gage Placement for Coastal Project Monitoring

<p>I. High-budget project (major harbor; highly populated area)</p> <p>A. Recommended placement:</p> <ol style="list-style-type: none"> One (or more) wave gage(s) close to shore near the most critical features being monitored (example, near an inlet). Although nearshore, gages should be in intermediate or deep water based on expected most common wave period. Depth can be calculated from formulas in the <i>Shore Protection Manual</i> (1984). In addition, one wave gage in deep water. <p>B. Schedule:</p> <ol style="list-style-type: none"> Minimum: 1 year. Monitor winter/summer wave patterns. Optimum: 5 years or at least long enough to determine if there are noticeable changes in climatology over time. Try to include one El Niño season during coverage. <p>C. Notes:</p> <ol style="list-style-type: none"> Concurrent physical or numerical modeling: Placement of gages must be coordinated with modellers if field data will be used as input or calibration for models. Pre-existing wave data: may indicate that gages should be placed in particular locations. Alternative, may want to place gages in the identical locations as the previous deployment in order to make the new data as compatible as possible with the older data. Long, continuous datasets are extremely valuable! Complicated topography: If there is a complicated local topography near the critical project site (example: ebb tidal shoal at an inlet), it may be better to place the nearshore gage a few kilometres away where the isobaths are more parallel to the shoreline. Hazardous conditions: If there is a danger of gages being damaged by anchors or fishing boats, the gages must be protected, mounted on structures (if available), or deployed in a location that appears to be the least hazardous. 	
<p>II. Medium-budget project</p> <p>A. Recommended placement:</p> <ol style="list-style-type: none"> One wave gage close to shore near project site. Obtain data from nearest NOAA National Data Buoy Center (NDBC) buoy for deepwater climatology. <p>B. Schedule: minimum 1-year deployment; longer if possible</p> <p>C. Notes: same as IC above. Compatibility with existing data sets is very valuable.</p>	
<p>III. Low-budget, short-term project</p> <p>A. Recommended placement: gage close to project site.</p> <p>B. Schedule: if 1-year deployment is not possible, try to monitor the season when the highest waves are expected (usually winter, although this may not be true in areas where ice pack occurs).</p> <p>C. Notes: same as IC above. It is critical to use any and all data from the vicinity, anything to provide additional information on the wave climatology of the region.</p>	

Water Level Measurements and Observations

To collect continuous water level data for site-specific, modern process studies, tide gages must be deployed near the project site. Three types of instruments are commonly used to measure water level:

- *Pressure transducer gages.* These instruments are usually mounted on the seafloor or attached to structures. They record hydrostatic pressure, which is converted to water level during data processing. A major advantage of these gages is that they are underwater and somewhat inaccessible to vandals. In addition, those like the Sea Data Temperature Depth Recorder are compact and easy to deploy.
- *Stilling-well, float gages.* These instruments, which have been in use since the 1930's, consist of a float that is attached to a stylus assembly. A clockwork or electric motor advances chart paper past the stylus, producing a continuous water level record. The float is within a stilling well, which dampens waves and boat wakes. The main disadvantage of these gages is that they must be protected from vandals. They are usually used in estuaries and inland waterways where piles or bridges are available for mounting the well and recording box. Figure 17 is an example of tide data from Choctawhatchee Bay, Florida.
- *Staff gages.* Water levels are either recorded manually by an observer or calculated from electric resistance measurements. The resistance staff gages require frequent maintenance because of corrosion and biological fouling. The manual ones are difficult to use at night and during storms, when it is hazardous for the observer to be at the site.

Typically, water level measurements recorded by gages are related to an established datum, such as mean sea level. This requires that the gage elevations be accurately measured using surveying methods. The maximum water level elevations during extreme events can also be determined by examining water marks on structures or other elevated features.

Water level information over paleoenvironmental time scales has been investigated by researchers using stratigraphic coring, seismic techniques, and radiometric dating. The reconstruction of ancient sea levels is one of the powerful tools used in seismic stratigraphy (Payton 1977; Sheriff 1980).

Current Measurements and Observations

Need for coastal current data

Currents, both shore-normal and shore-parallel, play a significant role in shaping the geology of coasts. Knowledge of the magnitude and direction of currents at the coast allows the prediction of sediment movements and thus is basic to an understanding of landform development. Information concerning cross-shore (shore-normal) currents and sediment transport can assist in predicting beach profile change, while knowledge of longshore (shore-parallel) currents and associated transport can be used in predicting beach planview

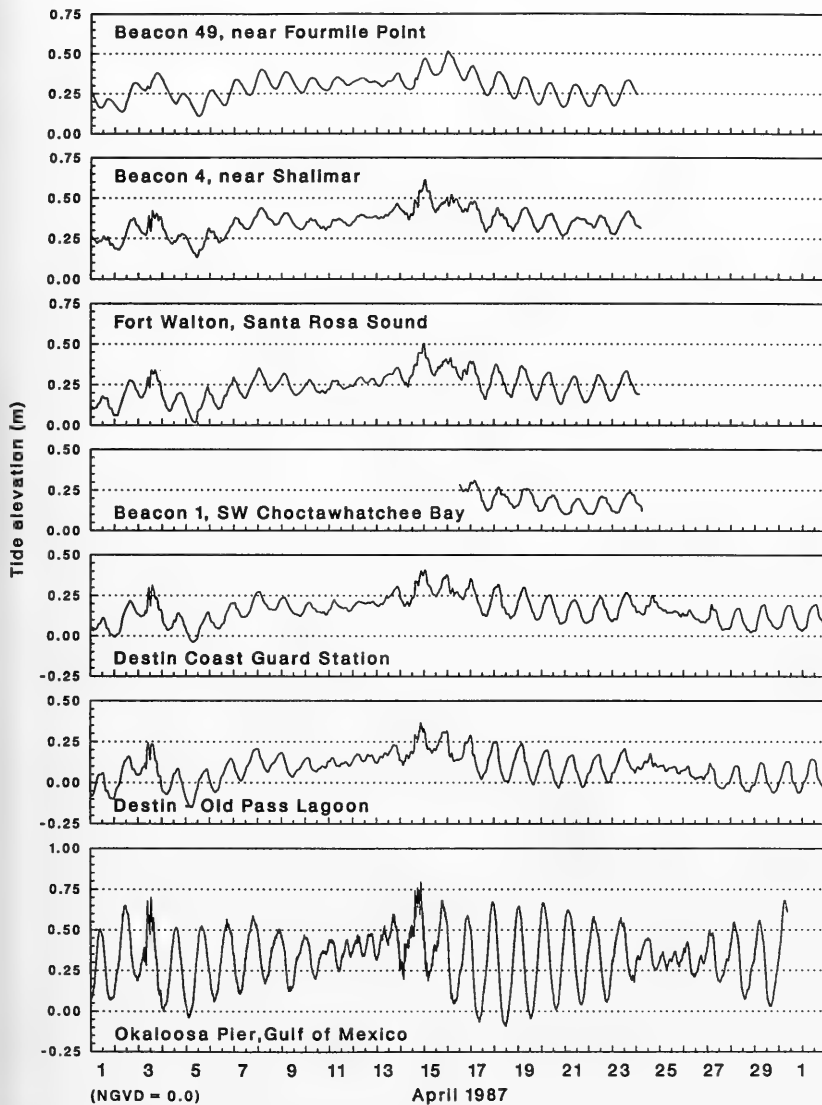

Figure 17. Tidal elevations from seven stations in Choctawhatchee Bay and vicinity, Florida. The overall envelope of the curves is similar, but individual peaks are shifted in phase from station to station. Original tide records courtesy of U.S. Army Engineer (USAE) District, Mobile

changes. Cell circulation, the combined effect of both types of currents, may explain or assist in identifying regularly spaced features along many coasts. The longshore migration of such cells may also cause accompanying landform migration.

An example of the interaction of topography and hydrodynamic forces is provided by rip currents. Rip currents extend perpendicular from the shoreline through the surf zone and serve as a conduit for water to escape from a zone of elevated water. The spacing of rip currents may be controlled by edge waves or other wave height variations along the surf zone (Bowen 1969; Bowen and Inman 1969; Tang and Dalrymple 1989). However, such wave height variations may not necessarily be the only cause of rip currents. Irregular nearshore topography, manifested by shoreline protuberances, may produce nearshore circulation cells (Sonu 1972). Rip currents are important geologically because they have been shown to carry significant amounts of sand offshore (Davidson-Arnott and Greenwood 1976; Sonu 1972). Rip currents can be located by observers at the shore and from aerial photographs. Their positions can also be identified indirectly by side-scan sonar when their characteristic rip-scoured channels are imaged on the seafloor (Morang and McMaster 1980).

The configuration of the shoreline can provide information regarding littoral currents. Shoreline protuberances, especially in the vicinity of structures, headlands and barriers, and tidal inlets are useful indicators of the prevailing longshore littoral drift (Komar 1976). Such indicators cannot generally be used for quantitative estimates of the sediment transport rate. Usually, transport rate must be calculated from: (a) direct evidence, such as sand impoundment in front of structures; (b) physical measurements of currents and sediment size and type; and (c) the use of longshore transport formulas, provided that local waves can be measured or hindcast.

General techniques of current measurement

The observation of hydraulic phenomena can be accomplished by two general approaches. One of these, Lagrangian, follows the motion of an element of matter in its spatial and temporal evolution. The other, Eulerian, defines the motion of the water at a fixed point and determines its temporal evolution. Lagrangian current-measuring devices are often used in sediment transport studies, in pollution monitoring, and for tracking ice drift. Eulerian, or fixed, current measurements are important for determining the variations in flow over time at a fixed location. Recently developed instruments combine aspects of both approaches.

Four general classes of current-measuring technology are presently in use (Appell and Curtin 1990):

- Radar and Lagrangian methods.
- Spatially integrating methods.

- Point source and related technology.
- Acoustic Doppler Current Profilers (ADCP) and related technology.

The large number of instruments and methods used to measure currents underscores that detection and analysis of fluid motion in the oceans is an exceedingly complex process. The difficulty arises from the large continuous scales of motion in the water. As stated by McCullough (1980), "There is no single velocity in the water, but many, which are characterized by their temporal and spatial spectra. Implicit then in the concept of a fluid 'velocity' is knowledge of the temporal and spatial averaging processes used in measuring it. Imprecise, or worse, inappropriate modes of averaging in time and/or space now represent the most prominent source of error in near-surface flow measurements." McCullough's comments were addressed to the measurement of currents in the ocean. In shallow water, particularly in the surf zone, additional difficulties are created by turbulence and air entrainment caused by breaking waves, by suspension of large concentrations of sediment, and by the physical violence of the environment. Trustworthy current measurement under these conditions becomes a daunting task.

Lagrangian

Dye, drogues, ship drift, bottles, temperature structures, oil slicks, radioactive materials, paper, wood chips, ice, trees, flora, and fauna have all been used to study the surface motion of the oceans (McCullough 1980). Some of these techniques, along with the use of mid-depth drogues and seabed drifters, have been widely used in coastal studies. A disadvantage of all drifters is that they are only quasi-Lagrangian sensors because, regardless of their design or mass, they cannot exactly follow the movement of the water (Vachon 1980). Nevertheless, they are particularly effective at revealing surface flow patterns if they are photographed or video recorded on a time-lapse basis. Simple drifter experiments can also be helpful in developing a sampling strategy for more sophisticated subsequent field investigations. Floats, bottom drifters, drogues, and dye are used especially in the littoral zone where fixed current meters are adversely affected by turbulence.

High-frequency (HF) radar surface-current mapping systems have been tested since the 1970's. The advantage of using the upper high radar frequencies is that these frequencies accurately assess horizontal currents in a mean water depth of only 1 m (total layer thickness about 2 m). Hence, HF radar accurately senses horizontal currents in the uppermost layers of the oceans, where other instruments such as moored current meters and ADCP's become inoperable (Barrick, Lipa, and Lilleboe 1990). Nevertheless, HF radar has had limited success in the oceanography community because of the difficulty in proving measurement accuracy and because of relatively high system costs (Appell and Curtin 1990).

Large-scale coastal circulation can be observed in satellite images, as seen in Figures 13 and 14.

Spatially integrating methods

To date, experiments in spatially averaging velocity by observing induced electrical fields have been conducted by towing electrodes from ships or by sending voltages in abandoned underwater telephone cables. Some of these experiments have been for the purpose of measuring barotropic flow in the North Pacific (Chave, Luther, and Filloux 1990; Spain 1990 - these two papers provide a substantial summary of the mathematics and methods). This author (Morang) is unaware of whether these techniques have been tested in shallow water or in restricted waterways such as channels. At this time, therefore, spatially integrating methods appear to have no immediate application to coastal engineering studies.

Point source (Eulerian) and related technology

In channels, bays, and offshore, direct measurements of the velocity and direction of current flow can be made by instruments deployed on the bottom or at various levels in the water column. Two general classes of current meters are available: mechanical (impeller-type) and electronic. Several types of electronic current meters are in common use, including electromagnetic, inclinometer, and acoustic travel-time (Fredette et al. 1990, McCullough 1980, Pinkel 1980).

Impeller current meters measure currents by means of a propeller device that is rotated by the current flow. They serve as approximate velocity component sensors because they are primarily sensitive to the flow component in a direction parallel to their axle. Various types of propeller designs have been used to measure currents, but experience and theoretical studies have shown that ducted propellers are more satisfactory in measuring upper ocean currents than rotor/vane meters (Davis and Weller 1980). Impeller/propeller meters are considered to be the most reliable in the surf zone (Teleki, Musialowski, and Prins 1976), as well as the least expensive. One model, the Endeco 174, has been widely used by CERC for many years throughout the country. Impeller gages are subject to snarling, biofouling, and bearing failures, but are more easily repaired in the field and are more easily calibrated than other types (Fredette et al. 1990).

Electronic current meters have many features in common, although they operate on different principles. Their greatest common advantages are rapid response and self-contained design with no external moving parts. They can be used in real-time systems and can be used to measure at least two velocity components. The degree of experience of the persons working with the instruments probably has more influence on the quality of data acquired than does the type of meter used (Fredette et al. 1990). The InterOcean Systems S4 electromagnetic meter has been successfully used recently by CERC at field experiments.

Acoustic Doppler Current Profilers (ADCP)

These profilers operate on the principle of Doppler shift in the backscattered acoustic energy caused by moving particles suspended in the water. Assuming that the particles have the same velocity as the ambient water, the Doppler shift is proportional to the velocity components of the water within the path of the instrument's acoustic pulse (Bos 1990). The backscattered acoustic signal is divided into parts corresponding to specific depth cells, often termed "bins." The bins can be various sizes, depending upon the depth of water in which the instrument has been deployed, the frequency of the signal pulse, the time that each bin is sampled, and the acceptable accuracy of the estimated current velocity. Much excitement has been generated by ADCP's, both among scientists working in shallow water and in the deep ocean (a comprehensive bibliography is listed in Gordon et al. 1990). A great advantage of using ADCP's in shallow water is that they provide profiles of the velocities in the entire water column, providing more comprehensive views of water motions than that from strings of multiple point source meters. ADCP data are inherently noisy, and signal processing and averaging are critical to the successful performance of the gages (Trump 1990).

Indirect estimates of currents

Indirect estimates of current speed and direction can be made from the orientation, size, and shape of bed forms, particularly in shallow water. Sedimentary structures on the seafloor are caused by the hydrodynamic drag of moving water acting on sediment particles. The form and shape of bottom structures reflect the effects of and interaction among tidal currents, waves, riverine flow, and longshore currents. These complex interactions especially affect bed forms in tidal channels and other restricted waterways. Bed forms reflect flow velocity, but are generally independent of depth (Clifton and Dingler 1984; Boothroyd 1985). Their shape varies in response to increasing flow strength (Hayes and Kana 1976). Bed form orientation and associated slipfaces also provide clues to flow direction (Morang and McMaster 1980; Wright, Sonu, and Kielhorn 1972). Widespread use of side-scan sonar has made this type of research possible in bays, inlets, and offshore.

Grab Sampling and Samplers

Seafloor sediments in coastal areas can show great spatial and temporal variation. The surface sediments may provide information about the energy of the environment as well as the long-term processes and movement of materials, such as sediment transport pathways, sources, and sinks. Bed surface sediments are typically collected with grab samplers and then analyzed using standard laboratory procedures. These tests are described briefly in this

report and in greater detail in other sources (Fredette et al. 1990; Buller and McManus 1979).

There are a variety of grab type samplers of different sizes and design that are used for collecting surface sediment samples. Most consist of a set of opposing, articulated scoop-shaped jaws that are lowered to the bottom in an open position and are then closed by various trip mechanisms to retrieve a sample. Many grab samplers are small enough to be deployed and retrieved by hand; others require some type of lifting gear.

A simple and inexpensive dredge sampler can be made of a section of pipe that is closed at one end. It is dragged a short distance across the bottom to collect a sample. Unlike grab samples, the dredged samples are not representative of a single point and may have lost finer material during recovery. However, dredge samplers are useful in areas where shells or gravel that prevent complete closure of the jaws are present.

Although obtaining surficial samples is helpful for assessing recent processes, it is typically of limited value in stratigraphic study. Generally, the expense of running track lines in coastal waters for the sole purpose of sampling surficial sediments is not economically justified unless particularly inexpensive boats can be used. Occasionally, grab and dredge samples can be taken during geophysical surveys, but the sampling operations require the vessel to stop at each station, thus losing survey time and creating interrupted data coverage. Precise offshore positioning now allows grab samples to be collected at specific locations along the boat's track after the survey has been run and the data examined.

Stratigraphic Sampling

Sediments and sedimentary rock sequences are a record of the history of the earth and its changing environments, including sea-level changes, paleoclimates, ocean circulation, atmospheric and ocean geochemical changes, and the history of the earth's magnetic field. On a global scale, the greatest influences on the coastal zone are sea level fluctuations and plate tectonics. By analyzing stratigraphic data, the age relations of the rock strata, rock form and distribution, lithologies, fossil record, biopaleogeography, and episodes of erosion and deposition at a coastal site can be determined. Erosion removes part of the physical record, resulting in unconformities. Often, evidence of erosion can be interpreted using physical evidence or dating techniques.

Sediment deposits located across a zone that ranges from the maximum water level elevation to the depth of the wave base are largely indicative of recent processes. Within this zone in unconsolidated sediments, simple reconnaissance field techniques are available for collecting data. The techniques often use ordinary construction equipment or hand tools. Smaller efforts

require shovels, hand augers, posthole diggers, or similar hand-operated devices. Larger scale efforts may involve trenches, pits, or other large openings created for visual inspection, sample collection, and photography (Figure 18). Often, undisturbed chunk or block samples and disturbed jar or bag samples are hand carved from these excavations and taken back to the laboratory.

Rates and patterns of sedimentation can be determined using marker horizons. Marker horizons may occur in relation to natural events and unintentional human activities or they may be directly emplaced for the express purpose of determining rates and patterns of sedimentation. Recently, several studies have estimated rates of sedimentation in marshes by spreading feldspar markers and later measuring the thicknesses of materials deposited on the feldspar with cryogenic coring devices.

The petrology and mineralogy of rock samples can be used to identify the source of the sediment. This can indicate if river flow has changed or if coastal currents have changed directions.

Direct sampling of subbottom materials is often essential for stratigraphic studies that extend beyond historic time scales. Table 5 lists details on a number of subaqueous sediment sampling systems that do not require drill rigs. One system listed in Table 5, the vibracorer, is commonly used by geologists to obtain samples in the marine and coastal environments. Vibratory corers consist of three main components: a frame, coring tube or barrel, and a drive head with a vibrator (Figure 19). The frame consists of a quadrapod or tripod arrangement, with legs connected to a vertical beam. The beam supports and guides the core barrel and vibrator and allows the corer to be free-standing on the land surface or seafloor. The core may be up to 3 or 4 m long, which is adequate for borrow site investigations and many other coastal studies. Heavy duty, longer corers are available.

While common vibratory corers are capable of penetrating 5 m or more of unconsolidated sediment, actual performance depends on the nature of the subbottom material. Under unfavorable conditions very little sediment may be recovered. Limited recovery occurs for several reasons, chief among these being lack of penetration of the core barrel. In general, stiff clays, gravel, and hard-packed fine to very fine sands are usually most difficult to penetrate. Compaction and loss of material during recovery can also cause a discrepancy between penetration and recovery. In comparison with rotary soil-boring operations, vibratory coring setup, deployment, operations, and recovery are quite rapid. Usually a 3-m core can be obtained in a matter of minutes. Longer cores require a crane or some other means of hoisting the equipment, a procedure that consumes more time but is still comparatively rapid. Success with vibracoring depends on some knowledge of soil type beforehand.

Cores can be invaluable because they allow a direct, detailed examination of the layering and sequences of the subsurface sediment in the study area. The sequences provide information regarding the history of the depositional



Figure 18. Trench excavated in the edge of a sand dune, eastern Alabama near Alabama/Florida state line

environment and the physical processes during the time of sedimentation. Depending upon the information required, the types of analysis that can be performed on the core include grain size, sedimentary structures, identification of shells and minerals, organic content, microfaunal identification (pollen counts), X-ray radiographs, radiometric dating, and engineering tests. If only information regarding recent processes is necessary, then a box corer, which samples up to 0.6-m depths, can provide sufficient sediment. Because of its greater width, a box corer can recover undisturbed sediment from immediately below the seafloor, allowing the examination of microstructure and lamination. These structures are usually destroyed by traditional vibratory or rotary coring.

Table 5
Subaqueous Soil Sampling Without Drill Rigs and Casing

Device	Application	Description	Penetration depth	Comments
Petersen dredge	Large, relatively intact "grab" samples of seafloor.	Clam-shell type grab weighing about 1000 lb with capacity about 0.4 ft ³	To about 4 in.	Effective in water depths to 200 ft. More with additional weight.
Harpoon-type gravity corer	Cores 1.5- to 6-in. dia. in soft to firm soils.	Vaned weight connected to coring tube dropped directly from boat. Tube contains liners and core retainer.	To about 30 ft.	Maximum water depth depends only on weight. Undisturbed (UD) sampling possible with short, large-diameter barrels.
Free-fall gravity corer	Cores 1.5- to 6-in. dia. in soft to firm soils.	Device suspended on wire rope over vessel side at height above seafloor about 15 ft and then released.	Soft soils to about 17 ft. Firm soils to about 10 ft.	As above for harpoon type.
Piston gravity corer (Ewing gravity corer)	2.5-in. sample in soft to firm soils.	Similar to free-fall corer except that coring tube contains a piston that remains stationary on the seafloor during sampling.	Standard core barrel 10 ft; additional 10-ft sections can be added.	Can obtain high-quality UD samples.
Piggott explosive coring tube	Cores of soft to hard bottom sediments.	Similar to gravity corer. Drive weight serves as gun barrel and coring tube as projectile. When tube meets resistance of sea floor, weighted gun barrel slides over trigger mechanism to fire a cartridge. The exploding gas drives tube into bottom sediments.	Cores to 1-7/8 in. and to 10-ft lengths have been recovered in stiff to hard materials.	Has been used successfully in 20,000 ft of water.
Norwegian Geotechnical Institute gas-operated piston	Good-quality samples in soft clays.	Similar to the Osterberg piston sampler, except that the piston on the sampling tube is activated by gas pressure.	About 35 ft.	
Vibracorer	High-quality samples in soft to firm sediments. Dia. 3-1/2 in.	Apparatus is set on sea floor. Air pressure from the vessel activates an air-powered mechanical vibrator to cause penetration of the tube, which contains a plastic liner to retain the core.	Lengths of 20 to 40 ft. Rate of penetration varies with material strength. Samples a 20-ft core in soft soils in 2 min.	Maximum water depth about 200 ft.
Box corer	Large, intact slice of seafloor.	Weighted box with closure of bottom for benthic biological sampling.	To about 1 ft.	Central part of sample is undisturbed.

(Adapted from Hunt (1984))

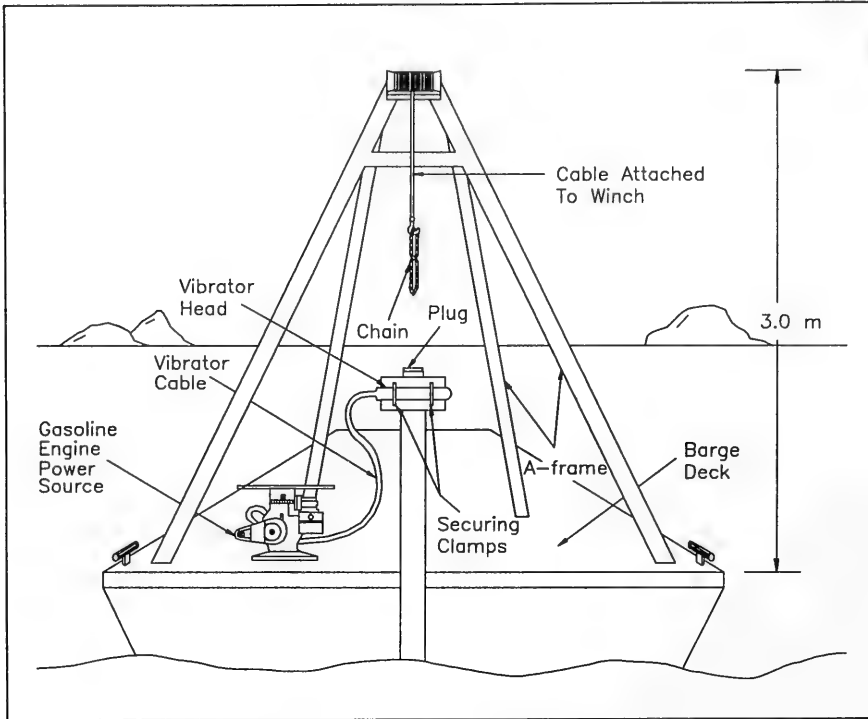

Figure 19. Front view of lightweight vibracorer mounted on a barge

If it is necessary to obtain deep cores, or if there are cemented or very hard sediments in the subsurface, rotary coring is necessary. Truck- or skid-mounted drilling rigs can be conveniently used on beaches or on barges in lagoons and shallow water. Offshore, rotary drilling becomes more complex and expensive, usually requiring jack-up drilling barges or four-point anchored drill ships (Figure 20). An experienced drilling crew can sample 100 m of the subsurface in about 24 hr. Information on drilling and sampling practice is presented in HQUSACE (1972) and Hunt (1984).

Sediment Movement and Surface Forms

Of great importance in investigations of geologic history is tracing sediment movement. This includes identifying the locations of sediment sources and sinks, quantifying sediment transport rates, and discovering the pathways. Sediment transportation is influenced by grain properties such as size, shape, and density, with grain size being most important. Differential transport of

coarse and fine, angular and rounded, and light and heavy grains leads to grading. Field visits to a locality are often repeated to assess temporal variability of these phenomena. Simultaneous measurement of energy processes such as current and waves is often required for understanding the rates and mechanisms of movement.

Measurement of sediment movement

The measurement of suspended and bed-load sediment movement in the surf zone is an exceedingly difficult process. There are a variety of sampling devices available for measuring suspended and bed-load transport in the field (Dugdale 1981; Seymour 1989), but these devices have not performed properly under some conditions or have been expensive and difficult to use. For these reasons, new sampling procedures are being developed and tested at CERC and other laboratories. Point measurements of sediment movement can be performed by two general procedures:

- Direct sampling and weighing of a quantity of material.
- Detection of the fluid flow by electro-optical or acoustic instruments deployed in the water.

Two general methods are available to directly sample the sediment in suspension and in bed load. First, water can be collected in hand-held bottles or can be remotely sucked into containers with siphons or pump apparatus. The samples are then dried and weighed. The second method is to trap a representative quantity of the sediment with a mesh or screen trap through which the water is allowed to flow for a fixed time. A fundamental problem shared by both methods is the question of whether the samples are truly representative of the sediment in transport. For example, how close to the seabed must the orifice be to sample bed load? If it is high enough to avoid moving bed forms, will it miss some of the bed load? Streamer traps made from mesh are inexpensive to build but difficult to use. The mesh must be small enough to trap most of the sediment but must allow water to flow freely. Kraus (1987) deployed streamers at Duck, NC, from stainless steel wire frames (Figure 21). Kraus and Dean (1987) obtained the distribution of longshore sand transport using sediment traps. A fundamental limitation of traps is that they can usually only be used in mild conditions. In winter and during storms it is too hazardous for the field technicians to maintain the equipment. Perversely, it is under these harsher conditions when the greatest sediment movement occurs. Another fundamental problem is relating the instantaneous measured suspended and bed-load transport to long-term sediment movement. Because of the extreme difficulty of conducting research in the surf zone, answers to these questions remain elusive.

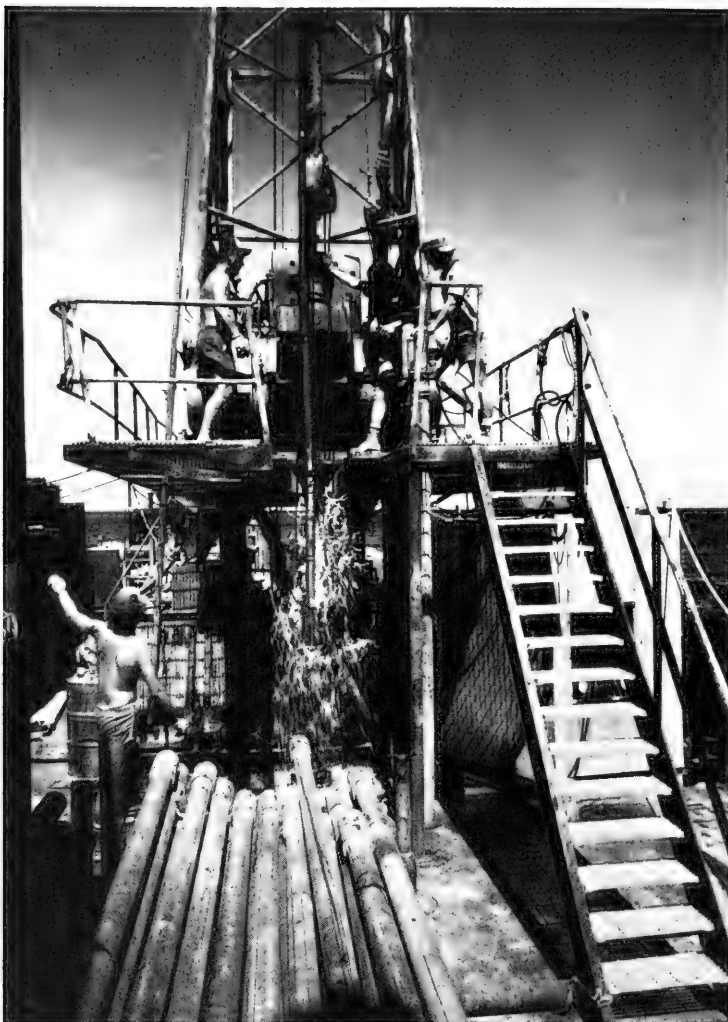

Figure 20. Rotary drilling operations under way in the estuary of the Guayacan River, Ecuador. In this area, layers of cemented coquina were very difficult to penetrate

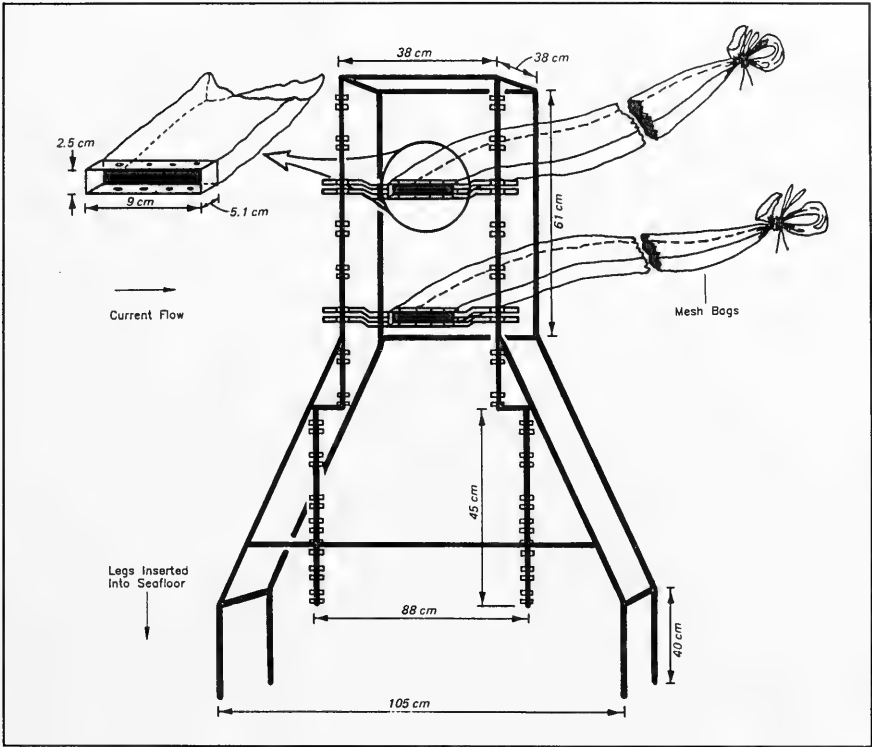

Figure 21. Side view of steel frame and polyester mesh sediment trap used at Duck, NC, by Kraus (1987) during CERC's DUCK-85 field experiments

Electronic instruments are being developed to detect or estimate sediment transport. They have some advantages over direct sampling procedures. These include the ability to measure the temporal variations of suspended or bed-load sediment and the ability to be used in cold water or in harsh conditions. (Note, however, that in severe storms, essentially no man-made devices have survived in the surf zone.) Their disadvantages include the difficulty of calibrating the sensors and testing their use with different types of sand and under different temperatures. In addition, many of these instruments are expensive and not yet commonly available. Sternberg (1989) and Seymour (1989) discuss ongoing research to develop and test new instruments for use in sediment transport studies in estuarine and coastal areas. Acoustic doppler current profilers are being tested and calibrated at CERC to determine

if they can be used to measure suspended sediment concentrations in the water column.

Sediment movement, both bed load or total load, can also be measured with the use of natural and artificial tracers (Dugdale 1981). Heavy minerals are an example of a natural tracer which has been used in studies of sediment movement (Komar et al. 1989; McMaster 1960). Natural sand can also be labelled using radioactive isotopes and fluorescent coatings (Teleki 1966). Radioactive tracers are not used any more because of health and safety concerns. When fluorescent dyes are used, different colors can be used simultaneously on different size fractions to differentiate between successive experiments at one locality (Ingle 1966). Artificial grains, which have the same density and hydraulic response of natural grains, can also be used in tracer studies. Aluminum cobble has been used by Nicholls and Webber (1987) on rocky beaches in England. The aluminum rocks were located on the beaches using metal detectors.

As with other phenomena, the experimental design for tracer studies may be Eulerian or Lagrangian. For the time integration or Eulerian method, the tracer grains are injected at a constant rate over a given interval of time. For space integration or the Lagrangian method, the tracers are released over an area at the same time. The choice of the method depends upon the nature of the problem. Field experiments must be designed carefully to isolate the parameter of interest that is to be measured or traced. For example, if the purpose of the study is to assess bed load transport, then care must be taken not to introduce tracers into the suspended load in the water column.

Bed forms

Introduction. When sediment is moved by flowing water, the individual grains are usually organized into morphological elements called bed forms. These occur in a baffling variety of shapes and scales. Some bed forms are stable only between certain values of flow strength. Often, small bed forms (ripples) are found superimposed on larger forms (dunes), suggesting that the flow field may vary dramatically over time. Bed forms may move in the same direction as the current flow, may move against the current (antidunes), or may not move at all except under specific circumstances. The study of bed form shape and size is of great value because it can assist in making quantitative estimates of the strength of currents in modern and ancient sediments (Harms 1969; Jopling 1966). This introduction to a complex subject is by necessity greatly condensed. For details on interpretation of surface structures and sediment laminae, readers are referred to textbooks on sedimentology such as Allen (1968; 1985), Komar (1976), Leeder (1982), Lewis (1984), and Reineck and Singh (1980).

In nature, bed forms are found in three environments of greatly differing characteristics:

- Rivers - unidirectional and channelized; large variety of grain sizes.
- Sandy coastal bays - semi-channelized, unsteady, reversing (tidal) flows.
- Continental shelves - deep, unchannelized; dominated by geostrophic flows, storms, tidal currents, wave-generated currents.

Because of the diverse natural settings and the differing disciplines of researchers who have studied sedimentology, the classification and nomenclature of bed forms has been confusing and contradictory. The following classification scheme, proposed by the Society for Sedimentary Geology (SEPM) Bedforms and Bedding Structures Research Group in 1987 (Ashley 1990) is suitable for all subaqueous bed forms:

- Ripples.* These are small bed forms with crest-to-crest spacing less than about 0.6 m and height less than about 0.03 m. It is generally agreed that ripples occur as assemblages of individuals similar in shape and scale. On the basis of crestline trace, Allen (1968) distinguished five basic patterns of ripples: straight, sinuous, catenary, linguoid, and lunate (Figure 22). The straight and sinuous forms may be symmetrical in cross section if subject to primarily oscillatory motion (waves) or may be asymmetrical if influenced by unidirectional flow (rivers or tidal currents). Ripples form a population distinct from larger-scale dunes, although the two forms share a similar geometry. The division between the two populations is caused by the interaction of ripple morphology and bed shear stress. At low shear stresses, ripples are formed. As shear stress increases above a certain threshold (which varies with grain size, fluid density, and other properties) a "jump" in behavior occurs, resulting in the appearance of the larger dunes (Allen 1968).
- Dunes.* Dunes are flow-transverse bed forms with spacings from under 1 m to over 1,000 m that develop on a sediment bed under unidirectional currents. These large bed forms are ubiquitous in sandy environments where water depths are greater than about 1 m, sand size coarser than 0.15 mm (very fine sand), and current velocities greater than about 0.4 m/sec. In nature, these flow-transverse forms exist as a continuum of sizes without natural breaks or groupings (Ashley 1990). For this reason, "dune" replaces terms such as megaripple or sand wave, which were defined on the basis of arbitrary or perceived size distributions. For descriptive purposes, dunes can be subdivided as small (0.6 - 5 m), medium (5 - 10 m), large (10 - 100 m), and very large (> 100 m). In addition, the variation in pattern across the flow must be specified. If the flow pattern is relatively unchanged perpendicular to its overall direction and there are no eddies or vortices, the resulting bed form will

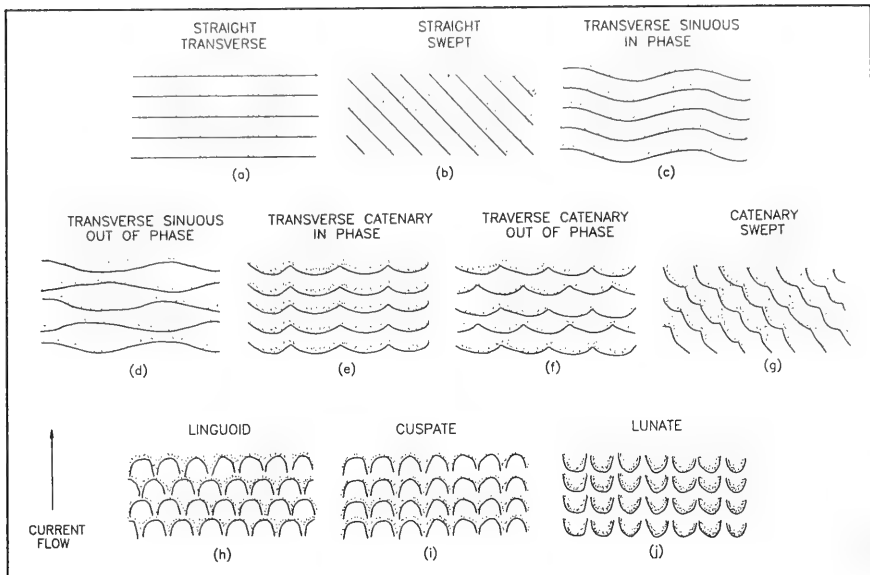

Figure 22. Plan view of basic ripple types (modified from Allen 1968)

be straight crested and can be termed two-dimensional (Figure 23a). If the flow structure varies significantly across the predominant direction and vortices capable of scouring the bed are present, a three-dimensional bed form is produced (Figure 23b).

- c. *Plane beds*. A plane bed is a horizontal bed without elevations or depressions larger than the maximum size of the exposed sediment. The resistance to flow is small, resulting from grain roughness, which is a function of grain size. Plane beds occur under two hydraulic conditions:

- The transition zone between the region of no movement and the initiation of dunes (Figure 24).
- The transition zone between ripples and antidunes, at mean flow velocities between about 1 and 2 m/sec (Figure 24).

- d. *Antidunes*. Antidunes are bed forms that are in phase with water surface gravity waves. They resemble regular dunes, but their height and wavelength depend on the scale of the flow system and characteristics of the fluid and bed material (Reineck and Singh 1980). Trains of antidunes gradually build up from a plane bed as water velocity increases. As the antidunes increase in size, the water surface changes

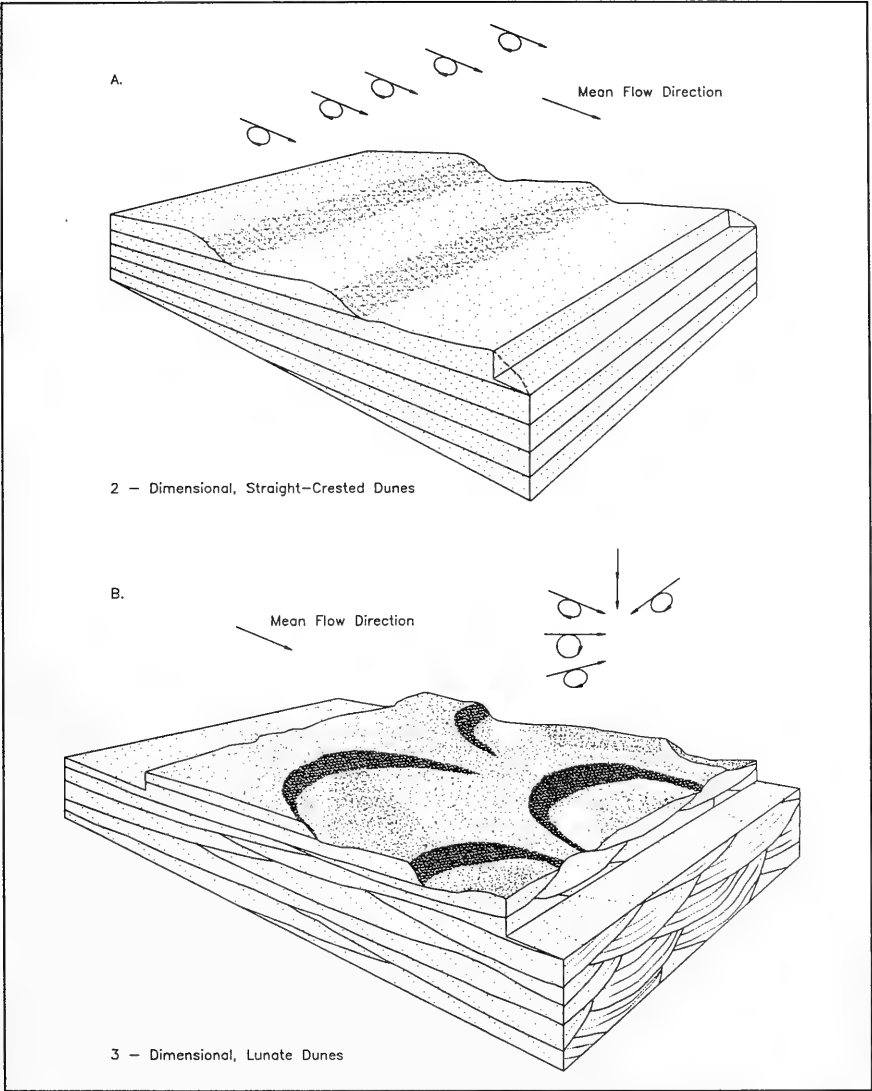

Figure 23. Two- and three-dimensional bed forms (adapted from Reineck and Singh (1980))

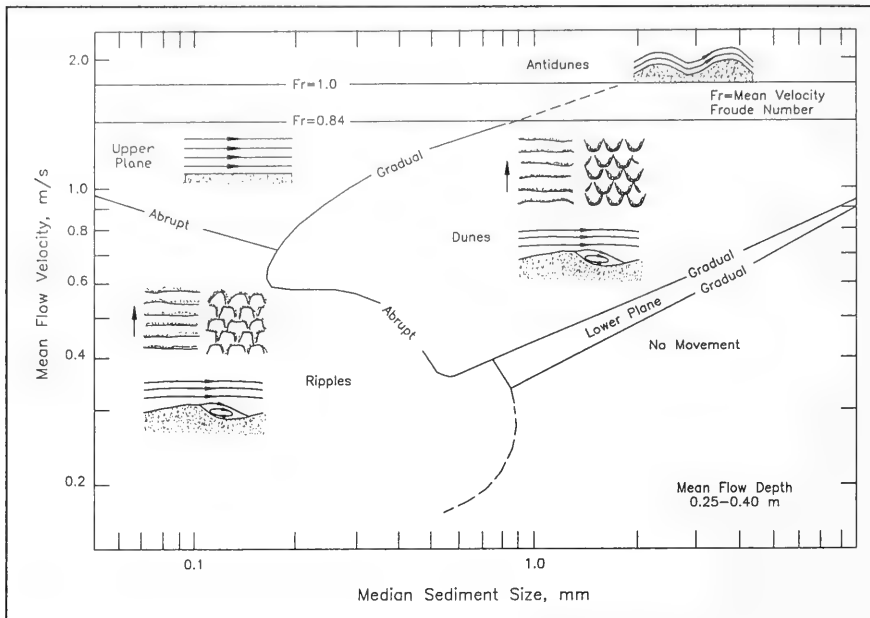

Figure 24. Velocity-grain size relationships for subaqueous bed forms (from Ashley (1990))

from planar to wave-like. The water waves may grow until they are unstable and break. As the sediment antidunes grow, they may migrate upstream or downstream, or may remain stationary (the name "antidune" is based on early observations of upstream migration).

- e. *Velocity - grain size relationships.* Figure 24, from Ashley (1990) illustrates the zones where ripples, dunes, planar beds, and antidunes are found. This figure is very similar to Figure 11.4 in Graf's (1984) hydraulics text, although Graf uses different axis units.

Use of subsurface structure to estimate flow regime. Several useful indices of foreset laminae, which may assist in making qualitative estimates of the strength of currents in modern and ancient sediments, are given by Jopling (1966). These include: (1) maximum angle of dip of foreset laminae (at low velocities the angle may exceed the static angle of repose, whereas at high velocities the angle is less than the static angle); (2) character of contact between foreset and bottomset (the contact changes from angular to tangential to sigmoidal with increasing velocity); (3) laminae frequency measured at right angles to bedding (there are more laminae per unit area with increasing velocity); (4) sharpness or textural contrast between adjacent laminae (at

higher velocities laminae become less distinct); and (5) occurrence of regressive ripples (regressive ripples indicate relatively higher velocities).

Measurements of bed forms can be accomplished on exposed sand banks at low water using surveying techniques or large-scale aerial photographs. Dimensionless parameters of ripples and other bed forms can indicate depositional environment (Tanner 1967). The flow directions can be assessed in terms of the trace of the crestline (Allen 1968). Wave-formed structures reflect the velocity and direction of the oscillatory currents as well as the length of the horizontal component of orbital motion and the presence of velocity asymmetry within the flow (Clifton and Dingler 1984). The flow strength for inter-tidal estuarine bed forms can also be estimated for a given flow depth by the velocity-depth sequence of bed forms (Boothroyd 1985).

Navigation and Positioning Equipment

Accurate positioning is essential for most geological monitoring studies. Several types of positioning and navigation systems are available for coastal studies, with the most common being Loran-C and Global Positioning Systems (GPS). Other technologies, such as short-range microwave and optical systems, are also in common use (Fredette et al. 1990).

Loran-C computes microsecond time differences using pulsed low-frequency radio waves between networks and receivers. The differences are then computed as lines of position. The receivers can be used up to about 2,000 km from the networks with reasonable accuracy. The absolute accuracy of Loran-C varies from 180 to 450 m, while the repeatable accuracy varies from 15 to 90 m.

GPS is a satellite navigation system developed by the U.S. Department of Defense. An array of satellites collectively provides precise, continuous, worldwide, all-weather, three-dimensional navigation and position for land, sea, and air applications. Use of GPS for hydrographic surveying is expanding, and procedures and equipment are improving rapidly.

Navigation (positioning) error standards have been established for USACE hydrographic surveys. Three general classes of surveys have been defined (HQUSACE 1991):

- Class 1 - Contract payment surveys
- Class 2 - Project condition surveys
- Class 3 - Reconnaissance surveys

Although the requirements of geologic site surveys may not be the same as those of USACE hydrographic surveys, the accuracy standards are useful criteria when specifying quality control requirements in contractual

documents. The frequency of calibration is the major distinguishing factor between the classes of survey, and directly affects the accuracy and adequacy of the final results. With the increasing use of GIS for analysis and manipulation of data, high standards of accuracy are imperative. Calibrations are time-consuming and reduce actual data collection time. Nevertheless, this must be countered with the economic impact that low quality data may be useless or may even lead to erroneous conclusions (leading, in turn, to incorrectly designed projects and possible litigation).

The maximum allowable tolerances for each class of survey are shown in Table 6.

Table 6			
Maximum Allowable Errors for Hydrographic Surveys			
Type of Error	Survey Classification		
	1 Contract Payment	2 Project Condition	3 Reconnaissance
Resultant Two-Dimensional One-Sigma RMS Positional Error Not to Exceed	3 m	6 m	100 m
Resultant Vertical Depth Measurement One-Sigma Standard Error Not to Exceed	± .152 m (± 0.5 ft)	± .305 m (± 1.0 ft)	± .457 m (± 1.5 ft)

(From HQUSACE (1991))

Table 7 depicts positioning systems that are considered suitable for each class of survey. The table presumes that the typical project is located within 40 km (25 miles) of a coastline or shoreline reference point. Surveys further offshore should conform to the standards in the NOAA Hydrographic Manual (National Oceanic and Atmospheric Administration 1976). Planning and successful implementation of offshore surveys are sophisticated activities and should be carried out by personnel or contractors with considerable experience and a successful record in achieving the accuracies specified for the particular surveys.

Geophysical Techniques

Geophysical survey techniques, involving the use of sound waves and high quality positioning systems on ocean vessels, are widely used for gathering subsurface geological and geotechnical data in terrestrial and subaqueous coastal environments. Geophysical procedures provide indirect subsurface data as opposed to the direct methods such as coring and trenching. The use of geophysical methods can assist in locating and correlating geologic materials and features by determining acoustic transparency, diffraction patterns, configuration and continuity of reflectors, and apparent bedding patterns.

Table 7
Allowable Horizontal Positioning System Criteria

Positioning System	Estimated Positional Accuracy (Meters RMS)	Allowable for Survey Class		
		1	2	3
Visual Range Intersection	3 to 20	No	No	Yes
Sextant Angle Resection	2 to 10	No	Yes	Yes
Transit/Theodolite Angle Intersection	1 to 5	Yes	Yes	Yes
Range Azimuth Intersection	0.5 to 3	Yes	Yes	Yes
Tag Line (Static Measurements from Bank)				
< 457 m (1500 ft) from baseline	0.3 to 1	Yes	Yes	Yes
> 457 m (1500 ft) but < 914 m (3000 ft)	1 to 5	No	Yes	Yes
> 914 m (3000 ft) from baseline	5 to 50 +	No	No	Yes
Tag Line (Dynamic)				
< 305 m (1000 ft) from baseline	1 to 3	Yes	Yes	Yes
> 305 m (1000 ft) but < 610 m (2000 ft)	3 to 6	No	Yes	Yes
> 610 m (2000 ft) from baseline	6 to 50 +	No	No	Yes
Tag Line (Baseline Boat)	5 to 50 +	No	No	Yes
High-Frequency EPS* (Microwave or UHF)	1 to 4	Yes	Yes	Yes
Medium-Frequency EPS	3 to 10	No	Yes	Yes
Low-Frequency EPS (Loran)	50 to 2000	No	No	Yes
Satellite Positioning:				
Doppler	100 to 300	No	No	No
STARFIX	5	No	Yes	Yes
NAVSTAR GPS:**				
Absolute Point Positioning (No SA)	15	No	No	Yes
Absolute Point Positioning (w/SA)	50 to 100	No	No	Yes
Differential Pseudo Ranging	2 to 5	Yes	Yes	Yes
Differential Kinematic (future)	0.1 to 1.0	Yes	Yes	Yes

* Electronic Positioning System
** Global Positioning System

(From HQUSACE (1991))

Inferences can often be made using these measures of stratigraphic and lithologic characteristics and important discontinuities.

Fathometers or depth sounders, side-scan sonar, and subbottom profilers are three major types of equipment used to collect geophysical data in marine exploration programs. All three systems use electrically powered acoustic devices that function by propagating acoustic pulses in the water and measuring the lapsed time between pulse initiation and the arrival of return signals reflected from various features on or beneath the bottom. These systems are used to obtain information on seafloor geomorphology, bottom features such as ripple marks and rock outcrops, and the underlying rock and sediment units. Acoustic depth sounders are used for conducting bathymetric surveys. Side-scan sonar provides an image of the aerial distribution of sediment and surface bed forms and larger features such as shoals and channels. It can thus be helpful in mapping directions of sediment motion. Subbottom profilers are used to examine the near-surface stratigraphy of features below the seafloor.

A single geophysical method rarely provides enough information about subsurface conditions to be used without actual sediment samples or additional data from other geophysical methods. Each geophysical technique typically responds to several different physical characteristics of earth materials, and correlation of data from several methods has been found to provide the most meaningful results. All geophysical methods rely heavily on experienced operators and analysts.

Bathymetric surveys are required for many studies of geology and geomorphology in coastal waters. Echo sounders are most often used to measure water depths offshore. Errors in acoustic depth determination are caused by several factors:

- Velocity of sound in water. The velocity in near-surface water is about 1500 m/sec but varies with water density, which is a function of temperature, depth, and salinity. For high-precision surveys, the acoustic velocity should be measured onsite.
- Boat-specific corrections. As the survey progresses, the vessel's draft changes as fuel and water are used. Depth checks should be performed several times per day to calibrate the echo sounders.
- Survey vessel location with respect to known datums. An echo sounder on a boat simply measures the depth of the water as the boat moves over the seafloor. However, the boat is a platform that moves vertically, depending on oceanographic conditions such as tides and surges. To obtain water depths that are referenced to a known datum, echo sounder data must be adjusted in one of two ways. First, tides can be measured at a nearby station and the echo sounder data adjusted accordingly. Second, the vertical position of the boat can be constantly surveyed with respect to a known land datum and these results added to

the water depths. For a class 1 survey, either method of data correction requires meticulous attention to quality control.

- **Waves.** As the survey boat pitches up and down, the seafloor is recorded as a wave surface. To obtain the true seafloor for the highest quality surveys, transducers and receivers are now installed on heave-compensating mounts. These allow the boat to move vertically while the instruments remain fixed. The most common means of removing the wave signal is by processing the data after the survey. Both methods are effective, although some contractors claim one method is superior to the other.

Even with the best efforts at equipment calibration and data processing, the maximum practicable achievable accuracy for nearshore depth surveys is about ± 0.15 m (HQUSACE 1991). The evaluation of these errors in volumetric calculations is discussed in Chapter 5. Survey lines are typically run parallel to one another, with spacing depending on the survey's purpose and the scale of the features to be examined.

In geophysical surveys, the distance between the sound source and reflector is computed as velocity of sound in that medium (rock, sediment, or water) divided by one half of the two-way travel time. This measurement is converted to an equivalent depth and recorded digitally or on a strip chart. A recent development that is valuable in bottom sediment interpretation is a signal processing unit that can be interfaced with an echo sounder and used to indicate the seafloor sediments in terms of Wentworth or other general classification schemes. This is accomplished by measuring two independent variables, roughness and hardness, from the acoustic signal and interpreting these data in terms of sediment type.

The principles of subbottom seismic profiling are fundamentally the same as those of acoustic depth sounding. Subbottom seismic devices employ a lower frequency, higher power signal to penetrate the seafloor (Figure 25). The transmission of the waves through earth materials depends upon the earth material properties, such as density and composition. The signal is reflected from interfaces between sediment layers of different acoustical impedance (Sheriff 1980). Coarse sand and gravel, glacial till, and highly organic sediments are often difficult to penetrate with conventional subbottom profilers, resulting in poor records with data gaps. Digital signal processing of multi-channel data can sometimes provide useful data despite poor signal penetration. Spacing and grid dimensions again depend upon the nature of the investigation and the desired resolution.

Acoustic characteristics are usually related to lithology so that seismic reflection profiles can be considered roughly analogous to a geological cross section of the subbottom material. However, because of subtle changes in acoustic impedance, reflections can appear on the record where there are minor differences in the lithology of underlying and overlying material. Also, significant lithologic differences may go unrecorded due to similarity of

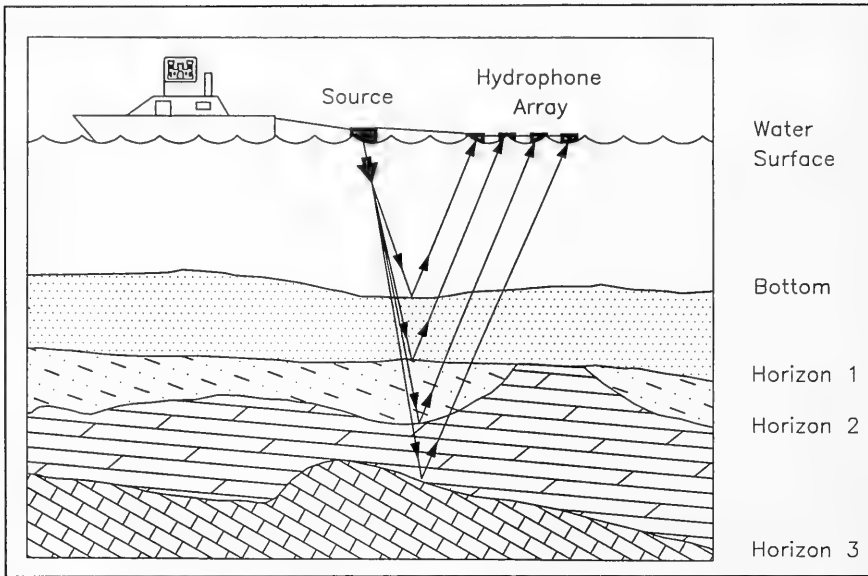

Figure 25. Principles of obtaining subbottom seismic data

acoustic impedance between bounding units, minimal thickness of the units, or masking by gas (Sheriff 1980). Because of this, seismic stratigraphy should always be considered tentative until supported by direct lithologic evidence from core samples.

The two most important parameters of a subbottom seismic reflection system are its vertical resolution, or the ability to differentiate closely spaced reflectors, and penetration. As the dominant frequency of the output signal increases, the resolution becomes finer. Unfortunately raising the frequency of the acoustic pulses increases attenuation of the signal and consequently decreases the effective penetration. Thus, it is a common practice to use two seismic reflection systems simultaneously during a survey; one having high resolution capabilities and the other capable of greater penetration.

Side-scan sonar is used to distinguish topography of the seafloor. Acoustic signals from a source towed below the water surface are directed at a low angle to either or both sides of a track line, in contrast with the downward-directed Fathometer and seismic reflection signals (Figure 26). The resulting image of the bottom is similar to a continuous aerial photograph. Detailed information such as spacing and orientation of bed forms and broad differences of seafloor sediments, as well as features such as rock outcrops, boulders, bed forms, and man-made objects, can be distinguished on side-scan. It is generally recommended that bathymetry be run in conjunction with side-scan to aid in identifying objects with subtle vertical relief. The side-scan

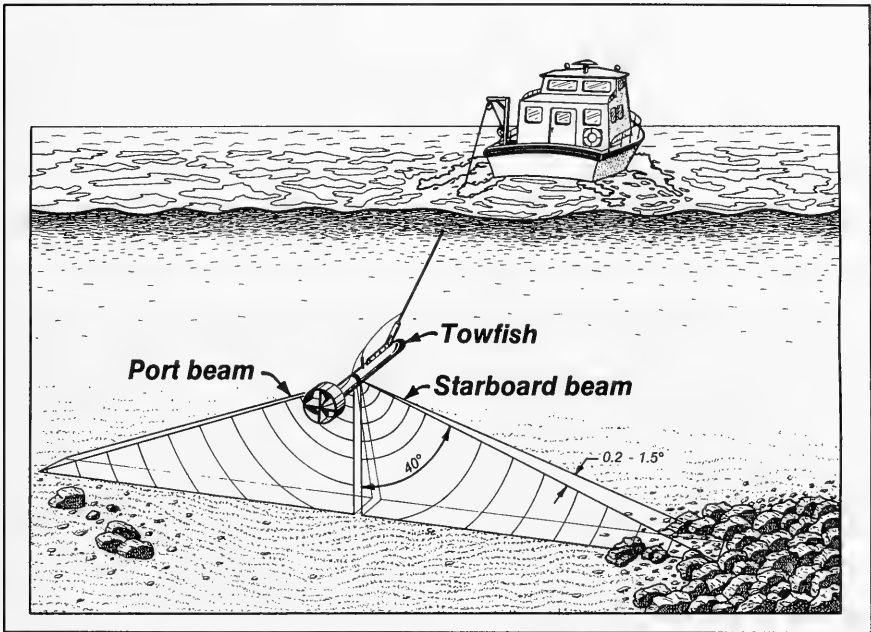

Figure 26. Side-scan sonar in operation

system is sensitive to vessel motion and is most suitable for use during calm conditions.

Commonly available side-scan sonar equipment, at a frequency of 100 kHz, is capable of surveying the seafloor to over 500 m to either side of the vessel track line; thus, a total swath of 1 km or more can be covered at each pass. To provide higher resolution output at close range, some systems are capable of dual operation using both 500-kHz and 100-kHz frequency signals. The data are simultaneously recorded on separate channels of a four-channel recorder. Digital side-scan sonar systems are available that perform signal processing to correct for both slant range to seafloor targets and survey vessel speed. The resulting records show true x-y location of seafloor objects, analogous to maps or aerial photographs. The digital data can be recorded on magnetic media, allowing additional signal processing or reproduction at a later date.

Ground-penetrating radar (GPR) is a relatively new technique for subsurface exploration. In contrast to the acoustic systems described above, GPR is used subaerially. The radio portion of the electromagnetic spectrum is emitted from the source and reflected back to the sensors. The transparency of geologic materials varies. Sands and limestones are typically reasonably

transparent. The use of GPR in marine environments is limited because salt water is non-transparent to electromagnetic radiation in the radio frequencies.

Morphologic and Bathymetric Profiles

Periodic topographic and nearshore bathymetric surveys constitute the most direct and accurate means of assessing geologic and geomorphic changes over modern time scales. Time series data, such as repeated beach profiles, allow the assessment of erosion and accretion in the littoral zone. The preferred surveying technique involves collecting a series of shore-normal profile lines. These must extend landward of the zone that can be inundated by storms, usually behind the frontal dunes.

Permanent or semi-permanent benchmarks are required for reoccupying profile sites over successive months or years. On rapidly transgressing coasts, these benchmarks should be located at the landward end of the profile line in order to minimize their likelihood of being damaged in storms. The locations of survey monuments must be carefully documented and referenced to other survey markers or control points. The ability to accurately reestablish a survey monument is very important because it ensures that profile data collected over many years will be comparable (Hemsley 1981). Locations that might experience dune burial should be avoided, and care should also be taken to reduce the visibility of benchmarks to minimize damage by vandals.

Both the frequency of the sampling and the overall duration of the study must be considered when planning a beach profiling study. Morphologic changes of beaches can occur over varying time scales, and if long-term studies are to be conducted, the dynamic nature of the beach should be taken into account. Often, it is financially or logistically impractical to conduct frequent, repeated surveys for a sufficient length of time to obtain reliable and comprehensive information on long-term processes at the study area. Nonetheless, resurveying of profile lines over a period of more than one year can be of substantial help in understanding the prevailing seasonal changes. Resurveying of control profile lines at selected time intervals can reveal seasonal patterns. In addition, special surveys can be made after significant storms and events to determine their effects and measure the rate of recovery of the local beach system. At a minimum, summer and winter profiles are recommended. Unfortunately, there are no definitive guidelines for the timing and spacing of profile lines. Table 8 outlines a suggested survey schedule for monitoring beach fill projects. In summary, observation over a period of time is recommended in order to document the range of variability of morphology and bathymetry.

Some issues concerning the spatial aspects of study include the spacing of profiles, longshore dimensions, and cross-shore dimensions. Profile lines should be spaced at close enough intervals to show any significant changes in

Table 8
Example of Beach Fill Area Profile Survey Scheme

Year	Times/Year	Number of Profiles
Pre-fill	2	Collect within fill area and at control locations in summer and winter months to characterize seasonal profile envelope (beach & offshore).
Post-fill	1	Collect all profiles immediately after fill placement at each site (beach & offshore) to document fill volume. Collect control profiles immediately after project is completed.
1	4	Four quarterly survey trips collecting all beach and offshore profiles out to depth of closure. Begin series during the quarter following the post-fill survey.
Continue year 1 schedule to time of renourishment (usually 4-6 years). If project is a single nourishment, taper surveys in subsequent years:		
2	2	6- and 12-month survey of all beach and offshore profiles
3	2	6- and 12-month survey of all beach and offshore profiles.
4	1	12-month survey of beach and offshore profiles.
<p>Note:</p> <ul style="list-style-type: none"> • If project is renourished, repeat survey schedule from post-fill immediately after each renourishment to document new fill quantity and behavior. • Project-specific morphology and process requirements may modify this scheme. • Monitoring fill after major storms is highly desirable to assess fill behavior and storm protection ability. Include both profile and sediment sampling. Conduct less than one week after storm conditions abate to document the beach and offshore response. 		

(From CERC (1991))

lateral continuity. In a cross-shore direction, the uppermost and lowermost limits of the profiles should be located where change is unlikely to occur, and should adequately cover the most active zones such as the shore and upper shoreface. The preferred closure depth is at the toe of the shoreface, although a selected depth contour where variability becomes minimal is acceptable. Historical shorelines are an important component of where these uppermost and lowermost limits are located, particularly along rapidly changing coastlines. For example, shore and dune deposits formed during earlier stages of development that are now distant from the modern shoreline are likely to be affected by marine or lacustrine processes only during large storms. Large-scale aerial photographs or maps of these interior areas are usually adequate for examining these more stable features. Appropriate longshore dimensions of the survey grid depend upon the nature of the problem. Profile lines should be connected with a shore-parallel survey to determine positions and elevations of each profile relative to one another.

Onshore portions of profiles are surveyed using standard land survey techniques and equipment. Equipment commonly used in surveys includes transits, levels, or theodolites, which are used for siting survey rods. Detailed information concerning the techniques and equipment available for surveying can be found in several surveying textbooks (i.e. Brinker and Wolf 1984).

Surveys are preferably conducted during low tide, when the profile line can be extended as far seaward as possible. Extending profile lines offshore beyond wading depths requires boats or amphibious vehicles. Amphibious vehicles are better suited to this task because they can traverse the sea-land boundary and maintain the continuity of profile lines. Although acoustic echo sounders can be used for continuous profiling seaward of the breaker zone, the signals are usually disrupted by breaking waves, and boats suitable for offshore use cannot approach the shore close enough to connect directly with a land profile. High-precision electronic navigation is recommended if the surveys extend offshore more than a few hundred meters.

During calm weather conditions, sea sleds have been successfully used to obtain shoreface profiles close to shore. A sea sled consists of a long, upright stadia rod mounted vertically on a base frame with sled-like runners (Clausner, Birkemeier, and Clark 1986) or a sled-mounted mast with a prism for use by a total station survey system (Fredette et al. 1990). The sled is towed, winched, or otherwise propelled along the profile lines (self-propelled, remote-controlled sea sleds are currently being developed) while frequent depth and position data are determined using onshore instruments. Because the sea sled does not float, elevations are not subject to wave or tide variations, thus providing a more accurate comparison between repeated surveys. At present, it is not possible to obtain bottom samples with a sea sled; these must be obtained from a boat or amphibious vehicle working in conjunction with the sled. Sleds are currently limited to use within 4 km of the coast and water depths of 12 m, less than the height of the sled masts.

A helicopter bathymetric surveying system has been in use at the USAE District, Portland, since the 1960's. The big advantage of this procedure is that land-accuracy surveys can be conducted offshore in high waves and near-structure conditions under which a boat could not perform. A helicopter is fitted with a weighted, calibrated cable and prisms. A total-station survey system is set up onshore to measure the location of the cable. Soundings are commonly taken at 8-m intervals along profile lines up to 2,500 m offshore. Operations are limited by poor visibility or winds over 15-20 m/sec (30-40 knots).

The Coastal Research Amphibious Buggy (CRAB), a unique self-propelled vehicle, was developed by the U.S. Army Corps of Engineers for making continuous onshore-offshore profiles and obtaining concurrent bottom samples. The CRAB consists of a structural tower mounted on wheels and is self-propelled by hydraulic motors. It can traverse under its own power across both the beach and shoreface to a depth of about 9 m. It has been widely used at the CERC Field Research Facility at Duck, NC. Both the CRAB and

sea sled are important tools for characterizing submarine bars and the overall morphology of offshore profiles.

Prototype Monitoring

Prototype testing and monitoring bring together multiple means of investigating and measuring the processes and responses of a coastal site. Prototype studies often involve physical experiments, conducted under ideal or well-monitored conditions in the field. The purpose of many prototype studies is to test and evaluate theoretical formulae or conceptual assumptions. Prototype studies, in other instances, are conducted to assess the status and variations of environmental conditions at a site and to develop information for guidance in the construction of structures.

4 Laboratory Techniques and Approaches

Laboratory Observation and Experiment

The characteristics of samples obtained in the field can be further analyzed in the laboratory. Some properties that are commonly examined include: (a) sediment properties, such as grain size, shape, and density, mineralogy, and heavy mineral type and content; (b) stratigraphic properties, which can be characterized using core description, preservation, and analysis techniques; and (c) geochronological history, obtained from radiometric dating and a variety of relative dating approaches. In order to achieve maximum benefits from laboratory analyses, the coastal scientist should be cognizant of the limitations and variance of the precision and accuracy of each test and procedure.

Laboratory Analysis of Sediment

Sediments are solid fragmental materials that originate from the weathering of rocks and are transported and deposited by water, air, or ice. Coasts that are comprised of sediment, in contrast to rock, are highly dynamic and are likely to have a complex geologic history. Analyses of the sediment characteristics, such as particle size, mineralogy, and heavy mineral content can reveal information about sources of materials, depositional environment, littoral processes, and the nature of coastal landforms. This knowledge of sediment characteristics, in turn, may be useful for predicting sediment movement during storms, the nature of seafloor features, and the geologic history of the area of investigation.

Sediments can be classified into size range classes. Ranked from largest to smallest, these include boulders, cobbles, gravel, sand, silt, and clay (Table 9). The particle size is often expressed as D , or the diameter in millimeters, and sometimes includes a subscript, such as D_{84} , to indicate the diameter corresponding to the listed percentile. As an alternative, grain size is often expressed in phi (ϕ) units, where $\phi = -\log_2 D$ (Hobson 1979). This

**Table 9
Sediment Particle Sizes**

Unified Soils Classification	ASTM Mesh No.	Size in mm	PHI Size	Wentworth Classification			
Cobble		4096.00	-12.0	Boulder	G		
		1024.00	-10.0				
		256.00	-8.0	Cobble		R	
		128.00	-7.0				
		107.64	-6.75	A			
		90.51	-6.5				
		76.00	-6.25				
		64.00	-6.0				
		58.82	-5.75			Pebble	V
		45.26	-5.5				
38.00	-5.25	E					
32.00	-5.0						
26.91	-4.75						
22.63	-4.5						
19.00	-4.25		Granule	L			
16.00	-4.0						
13.45	-3.75		S				
11.31	-3.5						
9.51	-3.25						
8.00	-3.0						
6.73	-2.75	Very Coarse		A			
5.66	-2.5						
4.76	-2.25	N					
4.00	-2.0						
3.36	-1.75						
2.85	-1.5						
2.35	-1.25		Coarse	D			
2.00	-1.0						
1.68	-0.75		Medium	S			
1.41	-0.5						
1.19	-0.25						
1.00	0.0						
0.84	0.25	Coarse		A			
0.71	0.5						
0.59	0.75	Medium		N			
0.50	1.0						
0.42	1.25						
0.35	1.5						
0.30	1.75		Fine	D			
0.25	2.0						
0.210	2.25		Very Fine	M			
0.177	2.5						
0.149	2.75						
0.125	3.0						
0.105	3.25						
0.088	3.5						
0.074	3.75						
0.0625	4.0	Silt		U			
0.053	4.25						
0.044	4.5	Clay		D			
0.037	4.75						
0.031	5.0						
0.0156	6.0						
0.0078	7.0						
0.0039	8.0						
0.0020	9.0		Clay	D			
0.00098	10.0						
0.00049	11.0		Colloid				
0.00024	12.0						
0.00012	13.0						
0.00006	14.0						

procedure assists in normalizing the grain size distribution and allows computation of other size statistics based on the normal distribution.

Grain-size analysis involves a series of procedures to determine what proportion of material in a given sample is in each grain size class. An important aspect of the laboratory analysis program, which must be designed into the field sampling scheme, is to obtain sufficient sediment to adequately determine the sediment population characteristics (Table 10). The requirement for obtaining adequate amounts of each sample underscores the importance of some prior knowledge of the field conditions or of conducting a preliminary field reconnaissance before undertaking a rigorous field sampling program. Large samples should be divided using a sample splitter to prevent clogging of sieves. Particle aggregates, especially those in the silt-clay range which show cohesive properties, should be separated and dispersed by gentle grinding and use of a chemical dispersant (sodium hexametaphosphate) before analysis.

Maximum Particle Size	Minimum Weight of Sample, g
3.0 in.	64,000
2.0 in.	19,000
1.5 in.	8,000
1.0 in.	2,400
0.75 in.	1,000
0.50 in.	300
0.38 in.	150
No. 4 sieve	50

Laboratory techniques used to estimate sediment diameter depend in part on the grain size. Pebbles and coarser sediments can be directly measured with calipers or by coarse sieves. The grain-size distribution of sand is determined directly by sieve analysis, sedimentation tubes, or Coulter counter. For silt and clay-sized material, grain-size distribution is determined indirectly by hydrometer or pipette analysis, or the use of a Coulter counter. The size distribution of mixed sediments is determined by using a combination of sieve and hydrometer or pipette analyses. Practical procedures for conducting laboratory tests on sediment samples are covered by Folk (1980) and Lewis (1984). Laboratory manuals more oriented towards engineering applications include American Society for Testing and Materials (1964), Bowles (1986), and HQUSACE (1970). Although they describe some tests specific to geotechnical engineering practice, many procedures, such as grain size analyses, are universal.

Coastal sediments reflect the relative importance of various source areas, and thus differences in the relative importance of the process mechanisms in

sediment supply. Some sources of coastal sediments include river basins that empty into the coastal zone, nearshore cliffs and uplands that are denuded by waves, wind, transported material mass wasting, and slope wash, and sediments transported by longshore currents.

Because gravel and larger particles require more energy to be transported, they are typically found close to their source. In contrast, silt and clay, once entrained, may be transported long distances. The size fraction distribution is determined by the composition of the source rocks and weathering conditions. The mineralogy of sediments, especially clays, shows varying mineralogy controlled by source rocks and weathering conditions. Resistant minerals, such as quartz and feldspars, comprise most coastal deposits. However, as tracers, the least common minerals are generally the best indicators of source.

Heavy minerals can provide information regarding source and process and other aspects of geomorphic variability in the coastal zone (Brenninkmeyer 1978; Judge 1970; McMaster 1960; Neiheisel 1962). Pronounced seasonal variations in heavy minerals may occur in the beach and nearshore samples, with foreshore samples showing higher concentrations in winter than summer, and samples outside the surf zone showing lower concentrations in winter than summer. An explanation for this phenomenon is that light minerals are transported from the beach foreshore to deeper water during the winter and back again during the summer (Inman 1953; Nordstrom and Inman 1975).

Analysis of size and texture can also be used to distinguish among sediments that may have come from the same original source area. As an example, Mason and Folk (1958) used size analysis to differentiate dune, beach, and eolian sediments on Mustang Island, Texas.

A variety of techniques are used to identify the mineralogy of coastal sediments. Mineralogy of coarse sediments and rocks is typically assessed using laboratory microscopes. Clay mineralogy is usually assessed with X-ray diffraction methods or electron microscopy. Heavy minerals are separated from light minerals using bromoform (specific gravity of 2.87) after crushing, washing, and sieving. In unconsolidated sediments, heavy mineral samples are examined under a microscope to determine approximations or percentages of mineral types.

Core Description and Analysis

Core description is widely used to characterize the features and depositional environments of sediments. After being collected in the field, core barrels are sealed to retain moisture. In the laboratory, they are cut in half lengthwise. One side of the core is used for description and the other for radiography, peels, and subsampling for grain size analysis, palynology, and organic materials. Cores may also be cut into smaller working sections depending upon the length of the working surface, such as a table, where the examination or tests will be conducted. They may also be cut further into

lengths of about 1 or 2 m so that a long core can be laid into a rack that will allow photography of the entire sequence.

A sample core description sheet is shown in Figure 27. Important characteristics of the sedimentary sequence that need to be described include grain size variations, sedimentary structures and directions, and occurrences of cyclic bedding such as varves. Evidence of plant roots and features such as color changes, mottling, discontinuities, and other variations in physical characteristics may be indicators of key changes. Roots and rooting, for example, often correspond to marshes in coastal sequences. Fossils and pollen in stratigraphic sequences are indicative of paleoenvironmental characteristics and changes. Techniques for analysis and interpretation of such evidence can be found in Faegri and Iverson (1975), and Kapp (1969).

Variations in grain size in cores can yield much information about the sedimentary environments and thus the geologic history of the region. Coarser fractions settle first, followed by silts and clays. This separation is a function of particle settling velocities, which vary depending upon particle size, density, shape, and the nature of the transport media. Changes in the environment of deposition can result in the clay fraction being separated from granular material both spatially and temporally. For example, clay deposits are usually deposited further from shore than granular material and usually appear on top of granular material.

X-ray radiography is an imaging method that amplifies contrasts in grain size, mineralogical composition, packing density, water content, diagenetic products, sedimentary structures, and geochemical inclusions in cores that otherwise appear homogeneous (Roberts 1981). Being able to distinguish these features may assist in understanding the sequence of geomorphic changes that occurred at that site. For example, the scale and direction of bed forms can be used to estimate paleocurrents. Marker horizons are related to a date or a significant event. Peat indicates stability and growth at or near sea level. Radiography is based on the differential transmission of X-ray radiation through a sample onto sensitized X-ray photographic film. Variations in texture as well as chemical composition throughout the sediment result in differential attenuation of the incident X-ray radiation before it reaches the underlying film. Samples of uniform thickness of about 1 cm that are cut longitudinally with a wire knife provide the best results in radiography (Roberts 1981).

The occurrence of paleosols in cores may also provide important information toward assessing the geologic history of coasts. In terrestrial coastal environments, there may be prolonged periods of minimal sedimentation during which soil development may occur, followed by periods of relatively rapid sedimentation without soil development¹. This scenario is characteristic of

¹ The term "soil" in this context refers to unconsolidated surficial sediment which supports plant life. This is a more restrictive definition than the one typically used in engineering texts, which refer to soil as any unconsolidated material, even if barren of plant life.

LITHOLOGIC LOG

Vibracore 44

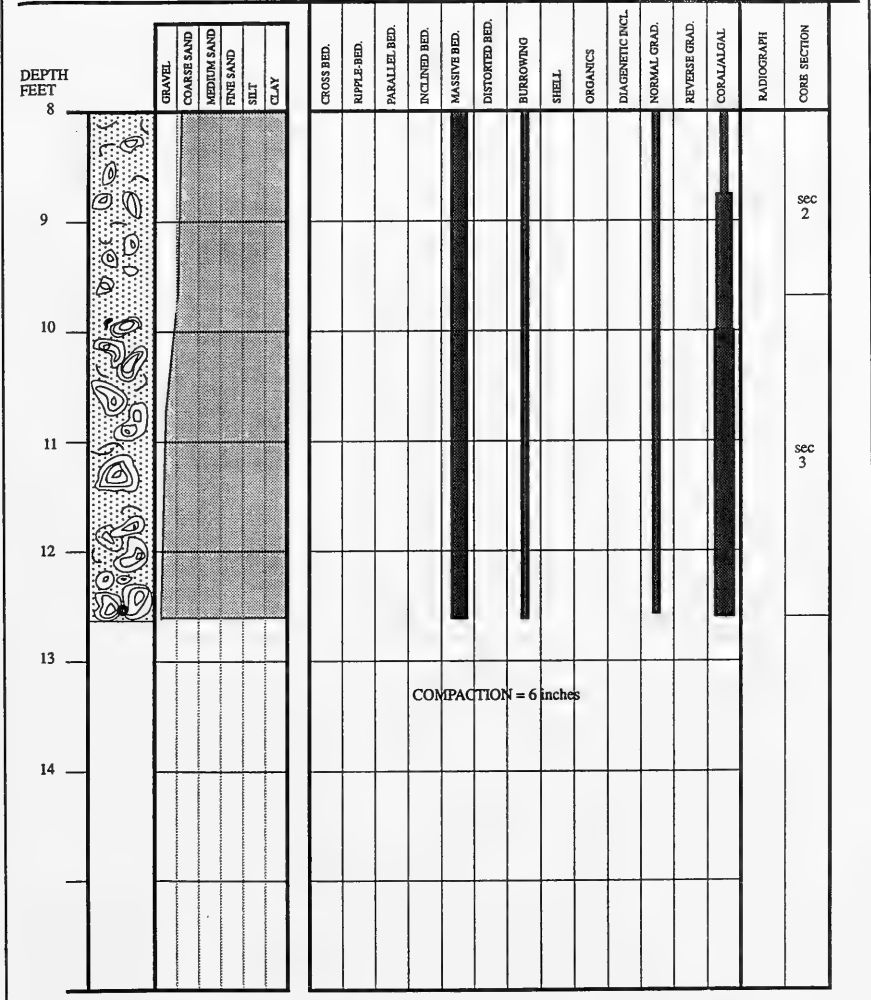

Figure 27. Sample form for core description of sedimentary environments (courtesy of Dr. Harry Roberts, Louisiana State University). Description of sediment size, sedimentary structures, and other geologic characteristics of the cores, as well as laboratory tests, assist in interpreting the depositional environment

recent sea level changes during the Quaternary. As alternative scenarios, such cycles could occur in a semi-protected salt marsh subject to sedimentation during a severe storm or in a soil that subsided as a result of rapid burial by other sediments. As with modern soils, horizon color and horizon assemblages based on color permit an initial identification. Important paleosols, which may reflect only limited pedogenesis, are represented only by thin, dark, organic horizons. Less apparent chemical and physical changes in sediments that were exposed to atmospheric and meteorological processes may also occur. Soils that are uniform over a wide area can sometimes be used as approximate marker horizons and thus are valuable for relative dating purposes. In some circumstances, soils may also contain enough organic material to be suitable for radiocarbon dating.

Differing degrees of soil development and weathering characteristics may also be helpful in correlating and determining relative ages of a series of marine terraces. Characteristics such as soil color, the thickness and color of clay skins, iron content, and the content of other basic elements and residual chemical elements in soils are some potential indicators of relative age. A variety of chemical analyses can be performed on field samples in the laboratory to determine soil chemistry, and the micromorphological characteristics of the soils can be assessed to determine soil development.

Geochronology

Geochronology is the study of time in relationship to the history of the earth. Geochronology encompasses a variety of radiometric and non-radiometric techniques, which collectively can date materials whose ages extend from near-present through the Pleistocene and earlier. Radiometric techniques vary in precision, in time range, in the types of materials that can be analyzed, and the type of information that results are capable of providing. Non-radiometric techniques that may be useful in coastal areas include archives, archeology, dendrochronology, thermoluminescence dating, magnetostratigraphy or paleomagnetic dating, paleoecology, the use of weathering and coating indices for relative age dating, and varve chronology. A detailed geochronology can provide information on the sequence of events and age of surfaces, and can assist in estimating missing (erosion or non-deposition) events. To be useful, it is important that the sample have a direct bearing upon a geomorphological problem and that the stratigraphic relationship of the sample to the site is well established. Use of multiple techniques typically provides the best results for assessing the geologic history of coasts.

Radiometric Dating and Isotopes

Radiometric dating techniques have been applied mostly since 1950. Many natural elements are a mixture of several isotopes, which have the same chemical properties and atomic numbers, but different numbers of neutrons and, hence, different atomic masses. Radiometric methods of dating are based

on radioactive decay of unstable isotopes. The duration of time leading to the state where half the original concentration remains is known as the half-life. In general, the useful dating range of individual isotopic methods is about 10 times their half-life. The radiometric isotopes Carbon-14, Potassium-Argon-40, Caesium-137, Lead-210, and Thorium-230 are the most commonly used in standard geologic investigations (Faure 1977; Friedlander, Kennedy, and Miller 1955).

Radiocarbon (Carbon-14 or ^{14}C) dating is perhaps the most widely used technique for assessing the age of Holocene and late Pleistocene organic materials. Once an organism or plant dies, its radiocarbon (^{14}C) content is no longer replenished and begins to decrease exponentially, achieving a half-life after some 5,730 years. Substances that are often examined with ^{14}C dating include wood, charcoal, peat, shells, bones, aqueous carbonates, rope, and soil organics. Recent developments using mass spectrometers allow detection of absolute amounts of ^{14}C content in samples as small as 5 mg. To be comparable, radiocarbon dates are adjusted to a zero age at AD 1950. Analytical error factors are given as one or two standard deviations about the mean. Other errors, associated with sample contamination, changes in atmospheric or oceanic ^{14}C content, and fractionation, are more difficult to estimate. Absolute dates of samples less than 150 years old or greater than 50,000 years old are currently considered to be ambiguous.

Potassium-argon dating (Potassium-Argon-40 or K:Ar) can be applied to a wide range of intrusive and extrusive igneous rocks that contain suitable minerals. In addition to constraints on rock type, it is necessary for the sample to be unaltered by weathering or other geological processes that may allow diffusion of radiogenic argon from the sample. The occurrence of such rocks along coasts is generally restricted to regions adjacent to plate boundaries and regions of active tectonics. Potassium-argon dating of Holocene deposits is generally imprecise, with errors of ± 15 to 30 percent. Only certain minerals, particularly those with a high K and low atmospheric Ar content, are suitable for extending the K:Ar dates into the late Pleistocene. For these reasons, potassium-argon dating has limited applications in studies of the geologic history of coasts.

Fission-track dating was developed as a complementary technique to potassium-argon (K:Ar) dating. Most applications to Quaternary deposits have involved dating airfall volcanic ash or glass deposits, a field known as tephrochronology. This material usually has wide distribution and geologically speaking has infinitely narrow depositional time duration. However, it is often absent or quickly removed in many coastal settings. If present, the rapid deposition and large aerial extent of ash makes it an excellent tool for correlation of rock strata and can provide radiometric age dates. A listing of some of the important volcanic ash layers in North America, which include very recent to Pleistocene dates, can be found in Sarna-Wojcicki, Champion, and Davis (1983).

Cesium-137 (^{137}Cs) is an artificial isotope, primarily produced during the atmospheric testing of nuclear weapons. These tests began in the 1940's, peaked in the early 1960s, and have declined since the advent of nuclear test ban treaties (Wise 1980). ^{137}Cs is strongly absorbed onto sediment or soil and has been used in studies of soil erosion and sediment accumulation in wetlands, lakes, and floodplains. The timing of very recent events (post-1954) and human impacts on coastal ecosystems can be improved using such techniques.

Lead-210 (^{210}Pb) is an unstable, naturally occurring isotope with a half-life of just over 22 years and a dating range of 100 to 200 years (Oldfield and Appleby 1984; Wise 1980). It forms as part of a decay chain from Radium-226 which escapes into the atmosphere as the inert gas Radon-222. The excess or unsupported ^{210}Pb returns to the earth as rainfall or dry fallout, and can be separated from that produced by in situ decay. Applications in coastal environments are limited but show good potential. This technique would be of greatest value in low-energy environments and would allow documentation of the timing of recent events and human impacts on coastal ecosystems.

Thorium-230/Uranium-234 ($^{230}\text{Th}/^{234}\text{U}$), a useful dating technique which complements other methods, is applicable for dating coral sediments. The technique involves comparing the relative amounts of the radioactive isotope of thorium, ^{230}Th , with that of uranium, ^{234}U . Thorium-230 increases in coral carbonate from zero at the death of the organism to an equilibrium with Uranium-234 at 0.5 million years, allowing samples as old as middle Pleistocene to be dated.

Non-Radiometric Methods of Dating and Relative Dating

Archival and archeological documentation can assist in understanding the geologic history of coasts. Historical and social documents may contain detailed descriptions of timing of major storms, of ice movements, of shoreline changes, and of other catastrophic events. Historical records are most useful if they correspond to a particular date or specified range of time, as do newspaper reports. Archeological evidence can provide important clues for assessing Holocene environmental changes. Pottery, stone tools, coins, and other artifacts can be assigned ages and thus may be of assistance in dating surface and subsurface deposits. If discovered in a stratigraphic sequence, cultural artifacts provide a minimum age for deposits beneath and maximum age for deposits above. Archeological evidence, such as buried middens, inland ports, or submerged buildings, may also indicate shoreline changes and sometimes can be used to estimate rates of deposition in coastal areas. For example, the Holocene Mississippi River deltaic chronology was revised using artifacts as indicators of the age of the deltaic surfaces (McIntire 1958).

Thermoluminescence (TL), a technique that is commonly practiced in archeology for dating pottery, has been extended for use in geological studies.

It has been used for dating a variety of Pleistocene sediments, including loess. For geological purposes, TL needs further refinement because most results to date are considered in error, generally being too young. It does, however, generally provide a good estimate of stratigraphic order. Thermoluminescence dating has the best potential where clay-fired artifacts are present and has promise for dating a variety of deposits of Quaternary age.

Magnetostratigraphy or paleomagnetic dating is a geochronologic technique that is used in conjunction with correlations of regional radiometric dates and paleomagnetic characteristics. Because the earth's magnetic field changes constantly, the magnetic characteristics of rock and sediments can be used to determine an age for materials. The most dramatic changes are reversals, in which the earth's polarity switches from the north to the south pole. The reversals are relatively infrequent occurrences, with the last one being 700,000 years ago. Less dramatic secular variations of the geomagnetic field, however, can also be important in helping to provide a time scale useful for dating over hundreds or thousands of years by linking magnetic properties with time scales established by radiometric techniques. The combination of declination (the angle between true and magnetic north), inclination (the dip of the earth's magnetic field), and the magnetic intensity produce a characteristic paleomagnetic signature for a particular location and time. The magnetic alignments can be incorporated and preserved in baked materials, in sediment particles that settle out in standing water, and in cooled magma. The technique is most suited to lake sediments containing homogeneous particle sizes and organics. This technique can be used in places where the magnetostratigraphy has been linked with radiometric dates and can be extended to over 200 million years before present.

Dendrochronology or tree ring dating can provide precise data regarding minimum age of a geomorphic surface. It can also provide proxy data concerning environmental stresses, including climatic conditions such as cold temperatures and droughts. In some parts of the world, overlapping sets of rings on trees have been used to construct a comprehensive environmental history of the region.

Lichenometry is the study of the establishment and development of lichen to determine a relative chronology (Worsley 1981). Although used most extensively for studies of glacier fluctuations, this technique also has application in shoreline dating. The method involves the measurement of thallus size, with increasing diameter representing increasing age. It is valid from about 10 years to a few centuries before present. This measurement is often conducted in the field with a ruler or with calipers. Field techniques differ, although normally the largest diameters are measured. Although there has been a lack of critical assessment of the technique, the majority of research shows that the technique gives reasonable dates when applied to a variety of environments.

Paleoecology is the study of fossil organisms in order to reconstruct past environments. Pollen analysis, or palynology, is the single most important

branch of paleoecology for the late Pleistocene and Holocene. Uses of paleoecological tools include: (a) the establishment of relative chronologies and indirect dating by means of correlation with other dated sequences; (b) characterization of depositional environments at or near the sampling site since certain species and combinations of species are adapted to certain conditions; (c) reconstruction of the paleoenvironmental and paleoclimatic conditions; (d) establishment of human-induced transformations of the vegetation and land use regime (Oldfield 1981).

The use of weathering and coating indices for relative age dating in geomorphology is rapidly increasing. Using laboratory microscopes, samples are calibrated with those of known age and similar chemistry for each geographic area. One such method, obsidian hydration dating, is based on the reaction of the surface of obsidian with water from the air or soil, which produces a rind whose thickness increases with time (Pierce, Obradovich, and Friedman 1976). Rock varnish-cation ratio dating is used primarily in deserts, where rocks develop a coating (Dorn 1983). One study used dated graffiti to determine the rates of erosion and weathering in sandstone cliffs (Emery 1941).

Varve chronology may be useful in quiescent or low energy basins where thin laminae of clay and silt are deposited. In glaciated coastal areas, the thin layers or varves are usually annual deposits. The sequences of successive graded layers can be discerned visually. Color variations occur because usually the winter season deposits have a higher organic material content. The result is alternating light-colored, gray-brown sediment layers and dark-colored organic layers.¹ Varve chronology rarely extends beyond about 7,000 years.

A major limitation of varve chronology is the fact that in the marine environment, annual varves are usually only preserved in anoxic basins, where a lack of oxygen causes a dearth of bottom-dwelling animals. Otherwise, mollusks, worms, fish, and crustaceans thoroughly rework the seafloor. This reworking, known as bioturbation, thoroughly destroys near-surface microstructure in most of the shallow-water portions of the world's oceans. Examples of anoxic basins include portions of the Black Sea and Saanich inlet in British Columbia. The latter receives an annual input of clays from the Fraser River. Yearly variations in the discharge of the Fraser River's spring freshet cause changes in the varve thicknesses.

Physical Models

The use of physical models can be invaluable in understanding how geomorphic variability occurs in coastal areas. Physical modelling provides

¹ In freshwater lakes, varves are caused by clay-silt deposition cycles. The silt settles out in spring and summer, and the clay in fall and winter.

an opportunity for reducing the complexity of natural systems, for scaling down dimensions, and for accelerating change over time so that detailed interactions can be identified. Physical models can be applied in studies of hydrodynamics, sediments, and structures. In studies of coastal processes and responses, the wave tank is both the simplest and the most utilized physical model.

Physical models are typically either two- or three-dimensional. A wave tank is considered to be a two-dimensional model because changes over length and over depth can be examined. Where variations over width are also investigated, the model is considered to be three-dimensional. A three-dimensional model or basin may have a variety of types of bottoms, including beds that are fixed, fixed with tracers, or moveable. Physical models require precise scaling and calibration, and much design and construction expertise must be devoted to their initial construction. Once set up, however, they allow for direct measurement of process elements, repeated experiments over a variety of conditions, and the study and isolation of variables that are difficult to assess in the field.

Some examples of physical model experiments (conducted principally in wave tanks) that helped elucidate geomorphologic variability of coasts include studies of littoral drift blockage by jetties (Seabergh and McCoy 1982), breaker type classification (Galvin 1968), experiments of cliff erosion (Sunamura 1983), relationships of storm surge or short-term water level changes to beach and dune erosion, and studies of suspended sediment concentration under waves (Hughes 1988).

Large-scale physical models of harbors, rivers, and estuaries have been built and tested at WES in order to examine the effects of jetties, weirs, channel relocations, and harbor construction on hydrodynamics and shoreline changes in these complex systems. Measurements made by gages at prototype (i.e. field) sites have sometimes been used to help calibrate the physical models. In turn, the results of tests run in the physical models have identified locations where gages needed to be placed in the field to measure unusual conditions. An example is provided by the Los Angeles/Long Beach Harbor model (Figure 28). In operation since the early 1970's, it has been used to predict the effects of harbor construction on hydrodynamics and water quality. As part of this project, wave gages were deployed in the two harbors at selected sites. Figure 29 is an example of wave data from Long Beach Harbor. Although the two gage stations were only a few hundred meters apart, the instrument at sta 2 occasionally measured unusually high energy compared to sta 1. The cause of these energy events is unknown but is hypothesized to be related to long-period harbor oscillations.



Figure 28. Photograph of a portion of the Los Angeles/Long Beach Harbor physical model, operated by CERC, Vicksburg, MS. The instruments on metal tripods are water level gages

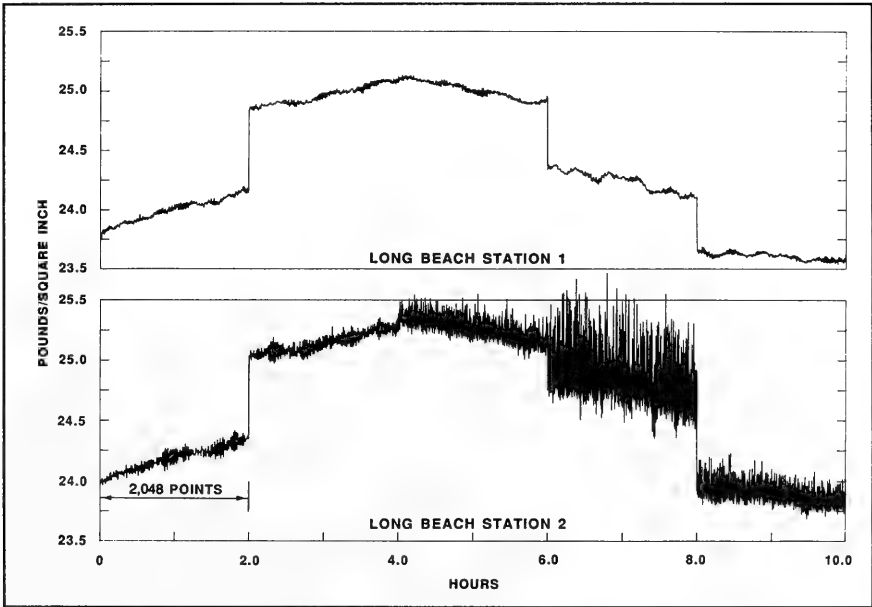

Figure 29. Comparison of wave gage pressure measurements recorded at Long Beach sta 1 and 2. Although the two stations were only a few hundred meters apart, unusual energy events were recorded at sta 2 which did not appear at sta 1. The abrupt shifts in the curve at each 2-hr interval represent changes in tide height. Each 2,048-point record is 34.13 min long and each new wave burst is recorded at a 2-hr interval

5 Analysis and Interpretation of Coastal Data

All geologic and engineering project data, whether obtained from secondary sources, field prototype collection, laboratory analyses, or physical models, must be analyzed and interpreted to ultimately be useful in studies of the geologic and geomorphic history of coasts. The analysis procedures depend upon the type of data collected. Some analyses require subjectivity or interpolation, such as constructing geologic cross sections or making seismic interpretations. Others are highly objective involving computer probabilistic models. A coastal scientist or engineer should be aware of the assumptions and errors involved, and should attempt to provide sufficient information so that his analyses can be replicated and the interpretation supported.

Computers play an important role in analysis and interpretation of data from various sources. Statistical techniques are applied to a variety of data, including: (a) spectral analysis of wave characteristics; (b) wave refraction analysis; (c) time series analysis of water level data; (d) Fourier analysis of current data; (e) moment measures of grain size; (f) eigenvectors of shoreline change; and (g) the use of fractals in shoreline geometry. Computers are also used for numerous types of calculations, such as volumetric changes in beach profiles, as well as two- and three-dimensional plotting of these changes. If numerous types of spatial data exist for a location, they may be entered into a GIS so that important questions can be addressed involving spatial changes. Computer software and hardware are also used for analysis, classification, and interpretation of digital remotely sensed data from satellites and aircraft.

The following sections will briefly outline some concepts and procedures pertinent to analyses of coastal data. The reader is referred to specialized texts for detailed descriptions of the underlying mathematics and data processing methods.

Wave Records

Importance of wave measurements

The measurement and analysis of wave data are of paramount importance to the understanding of coastal processes. The following quote from the *Shore Protection Manual* (1984) underscores reasons for obtaining wave parameters from the coastal zone:

Waves are the major factor in determining the geometry and composition of beaches and significantly influence the planning and design of harbors, waterways, shore protection measures, coastal structures, and other coastal works. Surface waves generally derive their energy from the winds. A significant amount of this wave energy is finally dissipated in the nearshore region and on the beaches.

Waves provide an important energy source for forming beaches; sorting bottom sediments on the shoreface; transporting bottom materials onshore, offshore, and alongshore; and for causing many of the forces to which coastal structures are subjected. An adequate understanding of the fundamental physical processes in surface wave generation and propagation must precede any attempt to understand complex water motion in the nearshore areas of large bodies of water. Consequently, an understanding of the mechanics of wave motion is essential in the planning and design of coastal works.

To an observer on the shore or on a boat, the sea surface usually appears as a chaotic jumble of waves of various heights and periods, moving in many different directions. Wave gages measure and record the changing elevation of the water surface. Unfortunately, these data, when simply plotted against time, reflect the complexities of the sea's surface and provide little initial information about the characteristics of the individual waves that were present at the time the record was being made (Figure 30). Once the water elevation data are acquired, further processing is necessary in order to obtain wave statistics that can be used by coastal scientists or engineers to infer which wave forces have influenced their study area.

Wave data analysis typically consists of a series of steps:

- Data transfer from gage to computer.
- Conversion of data from voltage readings to engineering units.
- Initial quality control inspection.
- Spectral analysis.
- Additional quality control (if necessary).
- Summary statistics in table and plot form.
- Plots of individual wave bursts or special processing.

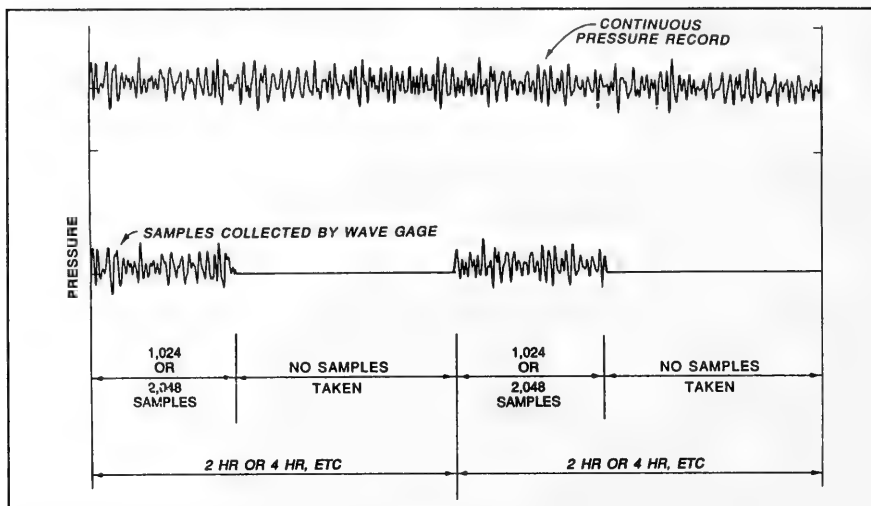

Figure 30. Example of continuous wave pressure record and wave burst sampling of pressure data

It is beyond the scope of this report to discuss details of the above procedures. This section will summarize some aspects of data collection, quality control, analysis, and terminology. Because of the complexity of the subject, the reader is referred to Bendat and Piersol (1986), Horikawa (1988), the *Shore Protection Manual* (1984), and Weaver (1983) for additional references.

Data collection planning

A continuous time series of raw pressure values plotted with time along the x-axis is shown in Figure 30. Because it is impractical and too expensive to collect data continuously throughout the day, discrete time series or "bursts" are collected at predetermined intervals (often every 2, 4, or 6 hr; Figure 30). Wave bursts typically consist of 1,024 or 2,048 consecutive pressure, U-velocity, and V-velocity¹ samples. At a sampling frequency of 1 Hz, these produce time series of 17.07 min and 34.13 min, respectively. Clearly, it would be desirable to acquire wave bursts frequently, but the sheer amount of data would soon overwhelm an analyst's ability to organize, interpret, and store the records. A researcher who plans a data acquisition program must balance the need to collect data frequently versus the need to maintain gages in the field for an extended period. There is a temptation to assume that as long as the gages are at sea, they should be programmed to collect absolutely as much data as possible. However, data management, analysis, and

¹ Orthogonal horizontal water velocity measurements.

archiving can cost at least as much as the deployment and maintenance of the gages. It is essential that these analysis costs be factored into the project budget. Typical sampling schemes used at CERC projects are listed in Table 11.

Instrument	Location	Sample interval, hr
Sea Data self-contained wave gage	Ocean coastlines	4 or 6
Sea Data self-contained wave gage	Great Lakes	2 or 3
CERC Directional Wave Gage (DWG)	Ocean coastlines	1
NOAA wave and meteorology buoys	Oceans and lakes	1

Quality control of wave data

One aspect of wave analysis, which is absolutely critical to the validity of the overall results, is the quality control procedures used to ensure that the raw data collected by the gages are truly representative of the wave climate at the site. Wave gages are subject to mechanical and electrical failures. The pressure sensors may be plugged or may be covered with growths while underwater. Nevertheless, even while malfunctioning, gages may continue to collect data which, on cursory examination, may appear to be reasonable. As an example, Figure 31 shows pressure records from two instruments mounted on the same tripod off the mouth of Mobile Bay, Alabama. The upper record in the figure is from a gage with a plugged pressure orifice. The curve reflects the overall change in water level caused by the tide, but high-frequency fluctuations caused by the passing of waves have been severely damped. The damping is more obvious when a single wave burst of 1,024 points is plotted (Figure 32). Without the record from the second gage, would an analyst have been able to conclude that the first instrument was not performing properly? This type of determination can be especially problematic in a low-energy environment like the Gulf of Mexico, where calm weather can occur for long periods.

Another difficult condition to diagnose occurs when the wave energy fluctuates rapidly. Many computerized analysis procedures contain user-specified thresholds to reject records that contain too many noise spikes. Occasionally, however, violent increases in energy do occur over a short time, and it is important that the analysis procedures do not reject these records. As an example, one of two gages in Long Beach Harbor (the lower curve in Figure 29) may have malfunctioned and written many noise spikes on the tape. In reality, the gage recorded unusual energy events within the harbor. Another example, from Burns Harbor, Indiana, is shown in Figure 33. When wave height was plotted against time, numerous spikes appeared. In this case, the rapid increase in energy was genuine, and the spikey appearance was caused by the plotting of many weeks of data on one plot. An examination of the individual pressure records (Figure 34) reveals how rapidly the energy

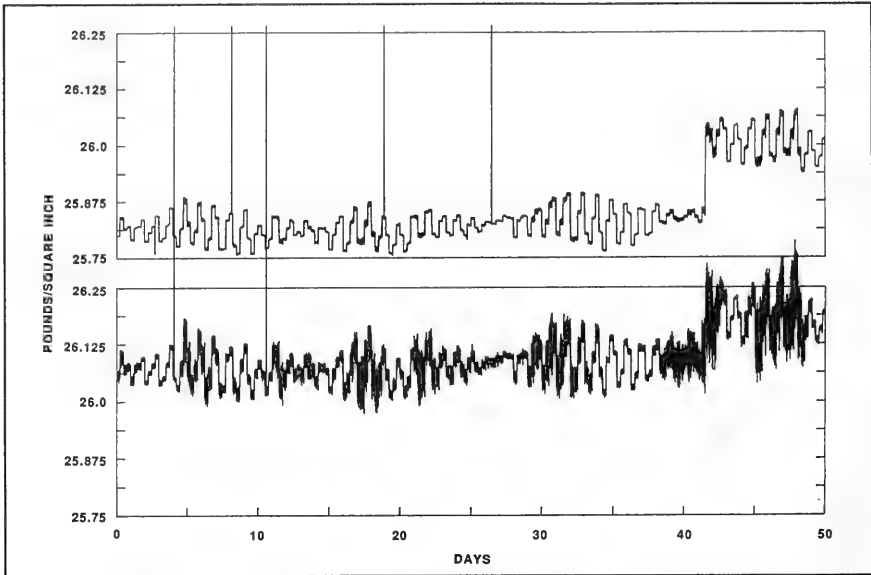

Figure 31. Pressure data collected by two gages mounted on a tripod off Mobile Bay, Alabama. The upper record is from a gage with a plugged pressure orifice. The abrupt increase in pressures near day 43 was caused when a fishing boat struck and overturned the tripod

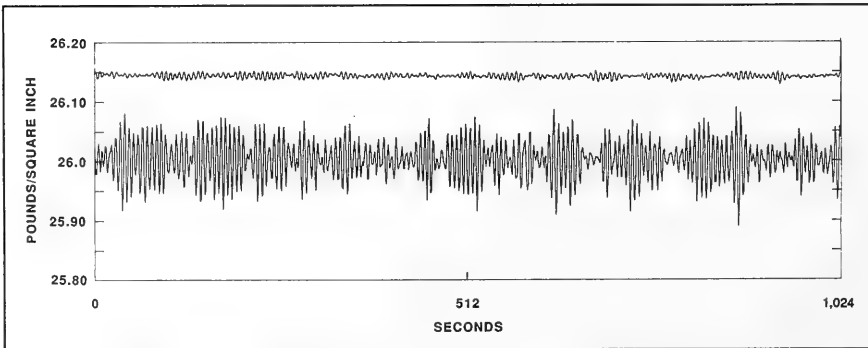

Figure 32. Example of a single wave burst of 1,024 pressure points from the same gages that produced the records in Figure 31. The data from the plugged gage (the upper curve) are not only reduced in amplitude but also shifted in phase. It is essentially impossible to correct the plugged data and recreate even an approximation of the original

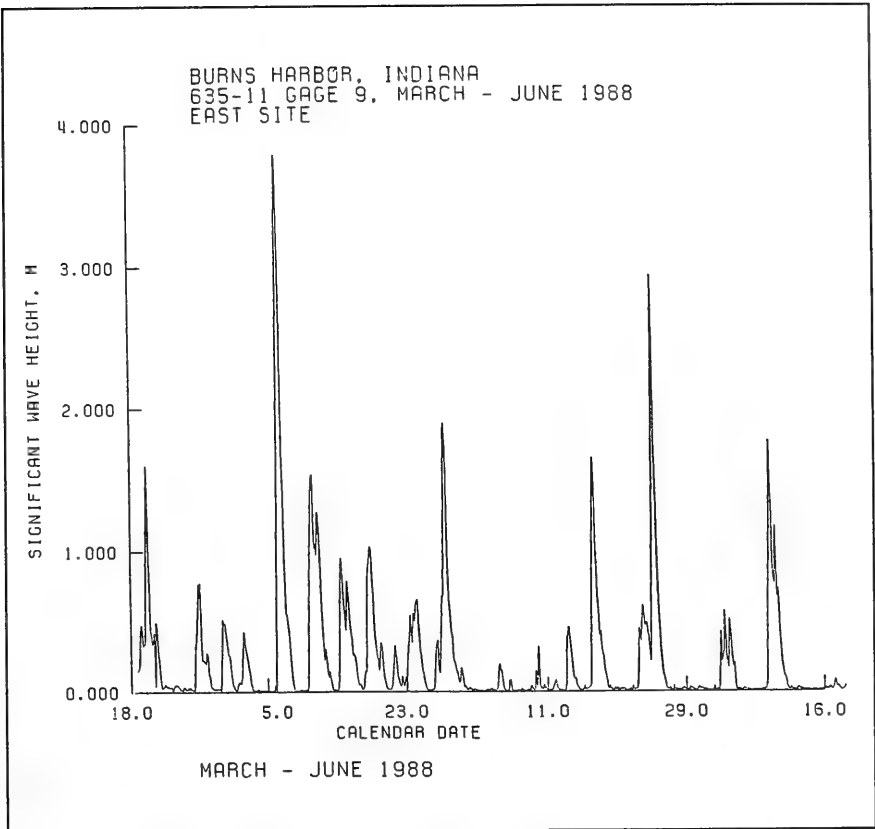

Figure 33. Analyzed wave data from Burns Harbor, Indiana. Spikey appearance is caused by plotting almost 3 months of data on one plot

increased in only a few hours (a characteristic of Great Lakes storms). This example demonstrates that the method of displaying wave statistics can have a major influence on the way the data are perceived by an analyst. Additional examples and quality control procedures for validating wave data are discussed in Morang (1990).

Analysis procedures and terminology

Wave data analysis can be broadly subdivided into non-directional and directional procedures. Although the latter are considerably more complex, the importance of delineating wave direction in coastal areas is usually great enough to justify the extra cost and complexity of trying to obtain directional

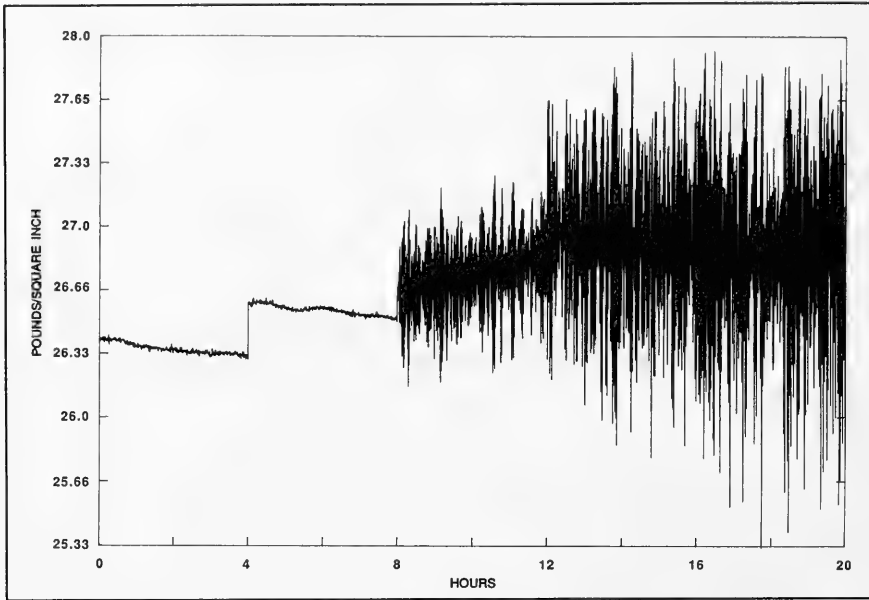

Figure 34. Pressure data from Burns Harbor, Indiana, April 6, 1988. This plot shows how dramatically the energy can increase in only a few hours

wave spectra. The types of wave statistics needed vary depending on the application. For example, a geologist might want to know what the average wave period, height, and peak direction are along a stretch of the shoreline. This information could then be used to estimate wave refraction and longshore drift. An engineer who is building a structure along the shore would be interested in the height, period, and approach direction of storm waves. He would use these values to calculate stone size for his structure. Table 12 lists common statistical wave parameters.

Table 12 is intended to underscore that wave analyses are complex procedures and should be undertaken by coastal researchers with knowledge of wave mechanics and oceanography. In addition, researchers are urged to be cautious of wave statistics from secondary sources and to be aware of how terms have been defined and statistics calculated. For example, the term "significant wave height" is defined as the average height of the highest one-third of the waves in a record (*Shore Protection Manual* 1984). How long should this record be? Are the waves measured in the time domain by counting the wave upcrossings or downcrossings? The two methods may not produce the same value of H_s . Might it not be better to estimate significant wave height by performing spectral analysis of a wave time series in the frequency domain and equating $H_s = H_{m0}$? This is the procedure commonly used in experiments where large amounts of data are processed. The latter

Table 12 Sea State Parameters		
Symbol	Description	Units
Basic Terms		
a	Amplitude	m
c	Phase velocity or celerity	m/s
c_g	Group velocity	m/s
f	Frequency	Hz
H	Wave height	m
L	Wave length measured in the direction of wave propagation	m
T	Wave period $1/f$	s
θ	Direction of wave propagation as used in directional spectra	deg
Δf	Basic frequency increment in discrete Fourier analysis	Hz
σ	Standard deviation	m
General Parameters		
f_p	Spectral peak frequency $1/T_p$	Hz
H_s	Significant wave height defined as the highest one-third of the wave heights calculated as $H_{1/3, \text{downcrossing}}$; or $H_{1/3, \text{upcrossing}}$	m
T_p	Spectral peak period $1/f_p$	s
Time Domain Analysis Functions		
$H_{1/3, d}$	Zero-downcrossing significant wave height. Average of the highest one-third zero-downcrossing wave heights	m
$H_{1/3, u}$	Zero-upcrossing significant wave height	m
Frequency Domain Analysis Parameters		
f_p	Spectral peak frequency. This frequency may be estimated by different methods, such as: (1) Frequency at which $S_{\eta}(ff)$ is a maximum; (2) Fitting a theoretical spectral model to the spectral estimates	Hz
H_{m0}	Estimate of significant wave height, $4\sqrt{m_0}$	m^2/Hz
m_n	n th moment of spectral density	m^2/s^n
$S(ff)$	Spectral density	m^2/Hz
T_p	Spectral peak period $1/f_p$	s
Directional Parameters and Functions		
k	Wave vector	rad/m
$d(f, \theta)$	Directional spreading function	deg
$S(f, \theta)$	Directional spectral density	$(\text{m}^2/\text{Hz})/\text{deg}$
α	Wave direction. This is the commonly used wave-direction parameter, representing the angle between true north and the direction from which the waves are coming. Clockwise is positive in this definition	deg
θ	Direction of wave propagation describing the direction of k . Counter-clockwise is positive	deg
$\Theta_m(ff)$	Mean wave direction as a function of frequency. The mean of all $\theta_m(ff)$ is known as the overall wave direction.	deg

(Adapted from IAHR Working Group on Wave Generation and Analysis (1989))

equivalency is usually considered valid in deep and intermediate water but may not be satisfactory in shallow water (Horikawa 1988).

Directional wave statistics are also subject to misinterpretations depending upon the computation method. At sea, very rarely do the waves come from only one direction. More typically, swell, generated by distant storms, may approach from one or more directions, while the local wind waves may have a totally different orientation. Researchers need to distinguish how the wave energy is distributed with respect to both direction and period (i.e., the directional spectral density, $S(f, \Theta)$). The directional distribution of wave energy is often computed by a method developed by Longuet-Higgins, Cartwright, and Smith (1963) for use with floating buoys in deep water. Other distribution functions have been proposed and used by various researchers since the 1970's (Horikawa 1988). Although the various methods do not produce the same directional wave statistics under some circumstances, it is not possible to state that one method is superior to another.

The user of environmental data must be aware of the convention used to report directions. Table 13 lists the definitions used at CERC; other institutions may not conform to these standards.

Table 13		
Reporting Conventions for Directional Environmental Measurements		
Type	Convention	Example
Wind	FROM WHICH wind is blowing	North wind blows from 0 deg
Waves	FROM WHICH waves come	West waves come from 270 deg
Unidirectional currents	TO WHICH currents are flowing	East current flowing to 90 deg

Some oceanographic instruments are sold with software that performs semi-automatic processing of the data, often in the field on PC computers. In some instruments, the raw data are discarded and only the Fourier coefficients saved and recorded. The user of these instruments is urged to obtain as much information as possible on the mathematical algorithms used by the gage's manufacturer. If these procedures are not the same as those used to analyze other data sets from the area, the summary statistics may not be directly comparable. Even more serious, this author (Morang) has encountered commercial processing software that was seriously flawed with respect to the calculation of directional spectra. In one field experiment, because the original raw data had not been archived in the gage, the data could not be reprocessed or the errors corrected. As a result, the multi-month gage deployment was rendered useless.

In summary, it is vital that the user of wave data be aware of how wave statistics have been calculated and thoroughly understand the limitations and strengths of the computational methods that were employed.

Display of wave data and statistics

In order to manage the tremendous amount of data that are typically acquired in a field experiment, perform quality control, and interpret the results, wave data should be analyzed as soon as possible. In addition, there is often an urgent need to examine the raw data to ascertain whether the gages can be redeployed or must be repaired.

Figures 30 and 32 are examples of pressure plotted against time. The value of this form of display for quality control purposes has been demonstrated, but these plots are of limited value in revealing information about the overall nature of the wave climate in the study area.

In order to review the data from an extended deployment, the summary statistics must be tabulated or plotted. Figure 35 is an example of tabulated directional wave data from a Florida project site. These same data are graphically displayed in Figure 36. The upper plot shows H_{m0} wave height, the center peak period, and the lower peak direction. Although other statistics could have been plotted on the same page, there is a danger of making a display too confusing. The advantage of the tabulation is that values from individual wave bursts can be examined. The disadvantage is that it is difficult to detect overall trends, especially if the records extend over many months. As data collection and processing procedures improve, and as more and more data are acquired at field projects, it will be increasingly difficult to display the results in a useful and flexible format that does not overwhelm the end user but yet also does not oversimplify the situation.

Applications of wave data

One important use of wave climate data in coastal engineering is in the construction of wave refraction diagrams. These demonstrate how nearshore bathymetry influences the direction of waves approaching the shoreline. This information can be used to estimate mass transport and longshore transport of sediment, which, in turn, can be used to predict morphologic changes under both natural and structurally influenced coasts. Wave refraction analyses can also be used for hypothetical scenarios, such as predicting the effects on incident waves of dredging an offshore shoal or dumping dredged materials offshore.

EAST PASS, DESTIN, FLORIDA
 635-9 GAGE 03
 APRIL - JUNE 1989
 (OFF OKALOOSA PIER, FT. WALTON BEACH)

ANALYSIS SUMMARY
 IUV Version 3.5
 20-JAN-90
 CEWEE-CD-P

MM	DY	YR	HRMN	HmO (M)	Tp (SEC)	Dp (DEG)	AVE.CUR (M/SEC)	C.DIR. (DEG)	DEPTH (M)
6	6	89	1230	0.64	5.4	182	0.34	296	9.8
6	6	89	1830	1.02	6.2	209	0.36	273	9.3
6	7	89	30	1.29	6.6	203	0.39	275	9.3
6	7	89	630	0.98	6.6	200	0.36	310	9.5
6	7	89	1230	0.91	6.6	204	0.24	301	9.8
6	7	89	1830	0.75	6.9	201	0.20	273	9.4
6	8	89	30	0.65	5.4	207	0.17	240	9.4
6	8	89	630	1.24	5.2	192	0.28	287	9.7
6	8	89	1230	2.21	7.3	200	0.60	297	10.0
6	8	89	1830	2.56	8.8	193	0.64	209	9.5
6	9	89	30	2.40	9.5	194	0.59	187	9.4
6	9	89	630	1.71	8.8	206	0.48	352	9.5
6	9	89	1230	1.45	7.8	202	0.40	203	9.7
6	9	89	1830	1.49	8.8	200	0.42	292	9.5
6	10	89	30	1.16	7.8	204	0.35	281	9.4
6	10	89	630	0.83	6.6	206	0.26	272	9.5
6	10	89	1230	0.83	7.3	198	0.25	279	9.6
6	10	89	1830	0.73	6.9	203	0.20	250	9.4
6	11	89	30	0.58	7.3	201	0.18	269	9.4
6	11	89	630	0.56	6.9	205	0.15	144	9.5
6	11	89	1230	0.56	6.6	203	0.15	15	9.5
6	11	89	1830	0.54	6.6	211	0.13	138	9.4
6	12	89	30	0.43	6.6	213	0.12	111	9.4
6	12	89	630	0.48	5.4	209	0.12	118	9.5
6	12	89	1230	0.49	4.5	224	0.10	109	9.4
6	12	89	1830	0.50	5.2	216	0.12	246	9.4
6	13	89	30	0.47	4.2	233	0.12	129	9.5
6	13	89	630	0.68	4.7	219	0.12	265	9.6
6	13	89	1230	0.67	5.0	225	0.17	271	9.4
6	13	89	1830	0.56	4.7	213	0.20	274	9.3
6	14	89	30	0.68	4.7	215	0.24	282	9.5
6	14	89	630	0.70	5.0	220	0.14	203	9.6
6	14	89	1230	0.67	5.2	212	0.14	254	9.4
6	14	89	1830	1.12	5.7	213	0.24	209	9.3
6	15	89	30	1.32	6.9	218	0.34	267	9.5
6	15	89	630	1.87	6.9	213	0.46	267	9.8
6	15	89	1230	1.97	8.3	201	0.51	269	9.5
6	15	89	1830	1.56	8.8	201	0.43	337	9.3
6	16	89	30	1.25	7.3	212	0.34	305	9.5
6	16	89	630	1.45	5.2	206	0.31	248	9.8
6	16	89	1230	1.91	7.8	203	0.48	3	9.4
6	16	89	1830	1.06	7.8	214	0.34	280	9.2
6	17	89	30	1.07	6.6	203	0.31	298	9.5
6	17	89	630	0.94	6.2	206	0.33	289	9.8
6	17	89	1230	0.77	6.0	198	0.21	260	9.5
6	17	89	1830	0.60	6.6	199	0.20	278	9.8
6	18	89	30	0.47	6.9	197	0.17	289	9.4
6	18	89	630	0.50	5.2	185	0.19	290	9.8
6	18	89	1230	0.49	6.0	180	0.22	270	9.6

Figure 35. Example of tabular summary of wave data from offshore Fort Walton Beach, Florida

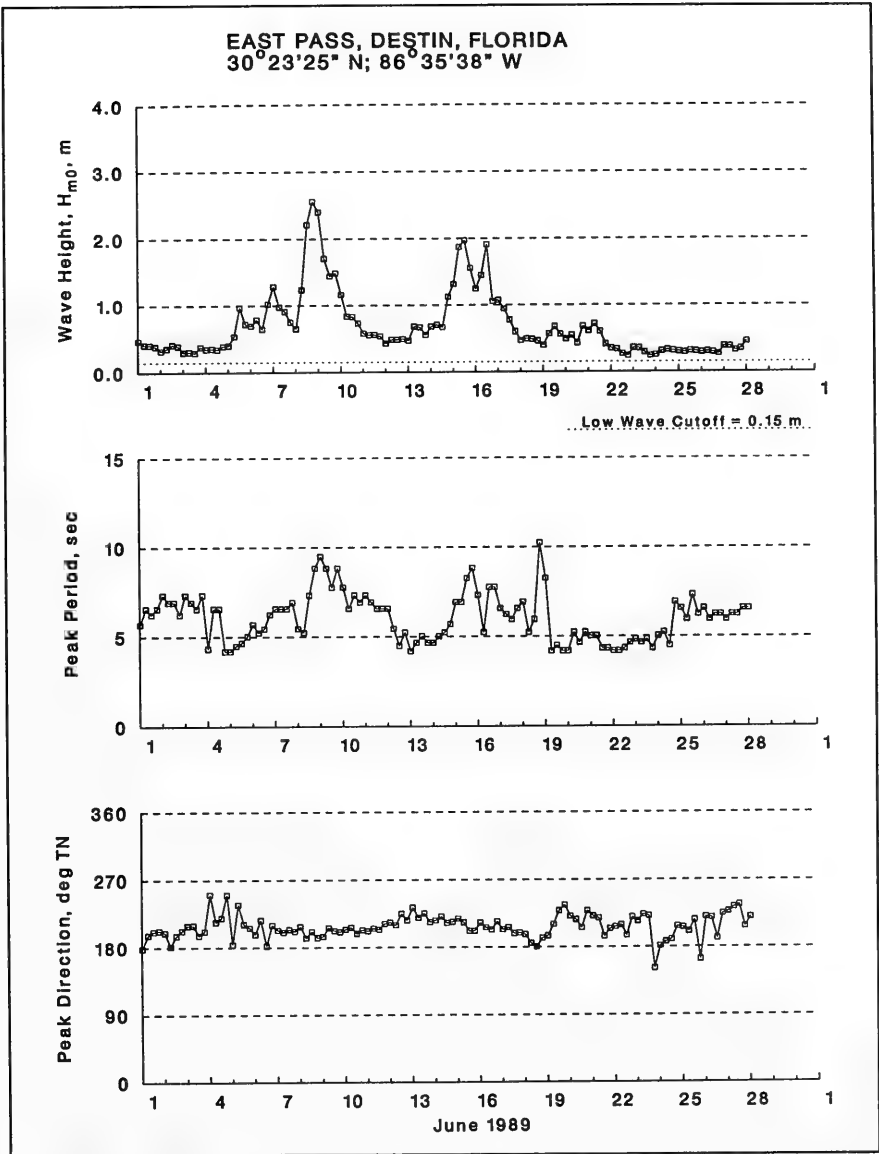

Figure 36. Plots of wave height, peak period, and peak direction from offshore Fort Walton Beach, Florida

Water Level Records

Marine (oceanic) coastlines

Changes in water levels along coastlines have profound influence on the geology, the natural ecology, and human habitation in these regions. Predicting and understanding these changes can guide coastal planners in developing rational plans for coastal development and in the design, construction, and operation of coastal structures and waterways. Sea level along open coasts varies in response to many natural processes on various temporal scales. Short-term factors are outlined in Table 14.

Table 14
Short-Term Sea-Level Changes Along Open Coastlines

* Periodic sea-level changes
Astronomical tides (diurnal and semidiurnal)
Long-period tides
The Chandler effect - changes in the rotation of the earth
* Meteorological and oceanographic contributions
Atmospheric pressure
The effects of winds - storm surges
The contribution of water density (temperature and salinity)
The effects of currents (meanders in western boundary currents)
Evaporation and precipitation
Ocean surface topography - ocean surface topography changes caused by density variations and climatic/current variations
El Niño/ southern oscillation
* Seasonal variations
Seasonal cycles (Atlantic, Pacific, Indian Oceans)
Seasonal variation in slope of the water surface
Seasonal water balance of the world's oceans
River runoff/floods - influential in inland seas
* Seiches
*Tsunamis - Earthquakes and mean sea level
Tsunamis - Short-term, catastrophic water level changes
Earthquakes - Changes in land levels

(Adapted from Emery and Aubrey (1991) and Lisitzin (1974))

Sea level changes over historical and geologic time scales are the subject of active research in the scientific community and the petroleum industry. The study of these changes has been hampered by the poor worldwide distribution of tide gages, as most gages were (and still are) distributed along the coasts of industrial nations in the Northern Hemisphere. Many of the geomorphic features with which we are familiar on contemporary coasts are the byproducts of the eustatic rise in sea level caused by Holocene climatic warming and melting of glaciers and ice sheets. The Holocene rise in sea level is well documented. Using the existing distribution of gages, it is not possible to assess if the rise is continuing because, while many gages record a recent rise in relative sea level (rsl), an equal number record a fall (Emery and Aubrey 1991).

The rsl has fluctuated throughout geologic time as the volume of ocean water has fluctuated, the shape of the ocean basins has changed, and continental masses have broken apart and reformed. Table 15 lists some of the factors contributing to long-term (geologic time scale) factors that have caused changes in rsl. Readers interested in details of this fascinating subject are referred to Emery and Aubrey's (1991) excellent book. This volume and Gorman (1991) contain extensive bibliographies of the subject. Detailed analyses of United States tide curves are documented in Hicks, Debaugh, and Hickman (1983).

Table 15
Long-Term Causes of Changes in Relative Sea Level

<ul style="list-style-type: none"> * Changes in ocean water volume <ul style="list-style-type: none"> Waxing and waning of glaciers and Arctic ice cap Juvenile water from volcanic eruptions Thermal effects - volcanism, hot spots, aesthenospheric bumps
<ul style="list-style-type: none"> * Plate tectonics and seafloor spreading <ul style="list-style-type: none"> Changes in spreading rates (affect the hypsometric curve - average depths of the ocean basins) Changes in areas of ocean and land Changes in direction of plate motions Deep-ocean sedimentation
<ul style="list-style-type: none"> * Isostasy (isostatic adjustment of the earth's crust) <ul style="list-style-type: none"> Glacio-isostasy - waxing and waning of glaciers Hydro-isostasy - changing water load on crust below ocean basins Sediment-isostasy - depositional-erosional cycles cause varying sediment load Glacial surges and melting
<ul style="list-style-type: none"> * Departures from the geoid (level surface of equal gravitational potential) <ul style="list-style-type: none"> Shifts in the hydrosphere, aesthenosphere, core-mantle interface Shifts in the rate of the earth's rotation, tilt of the spin axis, and precession of the equinox External gravitational changes
<ul style="list-style-type: none"> * Geological faulting <ul style="list-style-type: none"> Vertical and horizontal movement of large pieces of the crust in response to fault motions
<ul style="list-style-type: none"> * Sediment compaction and subsidence <ul style="list-style-type: none"> Reduction of volume of poorly packed sediments into more dense matrix - common in river deltas (Mississippi, Nile, Niger) Draining of low-lying areas Compaction under earthquake-induced vibration Compaction as a result of loss of interstitial fluids - oil drilling and withdrawal of groundwater for urban development

(Adapted from Emery and Aubrey (1991))

Tide gage records may be analyzed for spatial interpolation and for assessing temporal variations such as surges, tides, seasonal changes, and long-term trends. Discrepancies between the predicted tide at one site and the actual tide measured only a short distance away may be considerable. A method for adjusting between predicted tides at a station and those at a nearby study area using only limited field measurements is discussed by Glen (1979). Other analysis methods are discussed in HQUSACE (1989) and the *Shore Protection Manual* (1984).

For engineering projects, assessments of short-term water level changes range from simple plotting of the data to more sophisticated mathematical analyses. In some cases, some of the components which drive water level changes can be isolated. To assess longer (multi-year) trends, it is important to dampen or separate the effects of yearly variability so that the nature of the secular trends becomes more pronounced. Least-squares regression methods are typically inadequate because the secular trends often show pronounced nonlinearity (Hicks 1972). It may also be important to examine long-term periodic effects in a long data record such as the 18.6-year nodal period, which Wells and Coleman (1981) concluded was important for mud flat stabilization in Surinam.

West Coast of North America

The west coast of North America experiences extreme and complicated water level variations. Short-term fluctuations are related to oceanographic conditions like the El Niño-Southern Oscillation. This phenomenon occurs periodically when equatorial trade winds in the southern Pacific diminish, causing a seiche effect, which travels eastward as a wave of warm water. This raises water levels all along the U.S. west coast. Normally the effect is only a few centimetres, but during the 1982-83 event, sea level was elevated 35 cm at Newport, OR (Komar 1992). Seasonal winter storms along the Pacific Northwest can combine with elevated water levels to produce tides over 3.6 m. During the 1983 winter storms, water levels were up to 60 cm over the predicted level. Tectonic instability along the U.S. west coast affects long-term water level changes. Parts of the coast are rising and falling at different rates. Studies in Oregon have shown that the state's northern coast is falling while the southern part is rising relative to sea level (Komar 1992). Along Alaska, some areas of the coast are rising nearly 1 cm/year.

Great Lakes of North America

On the Great Lakes of North America (Lakes Superior, Huron, Michigan, Erie, and Ontario), astronomic tides have relatively little influence on water levels. Short-term level fluctuations are primarily caused by local atmospheric pressure changes and by winds. This is demonstrated in Figure 34, where the first three wave bursts are shifted vertically from each other. In addition, even during the recording of each 1,024-point burst (17.07 min long), the mean water level changed.

Long-term changes of water levels in the Great Lakes are caused by regional hydrographic conditions such as precipitation, runoff, temperature and evapotranspiration, snowmelt, and ice cover (Great Lakes Commission 1986). These factors in turn are affected by global climate variations. Crustal movements also influence levels. For example, the eastern end of Lake Superior is rebounding at a rate about 10 in./century faster than the western end, resulting in higher water at the west end at Duluth. Aquatic plant life

and man-made control structures are additional factors that influence the exceedingly complex cycles of water level changes in the Great Lakes. As a result, the concept of mean water level is not applicable to these inland Great Lakes, and attempts to predict lake levels have not been entirely successful (Walton 1990).

Historic water levels have been used by Hands (1979, 1980) to examine the changes in rates of shore retreat in Lake Michigan and to predict beach/nearshore profile adjustments to rising water levels. Additional research is being sponsored by the International Joint Commission to model how changing water levels affect erosion of various bluff stratigraphies and the nearshore profile.

Current Records

Current data are often critical for evaluating longshore and cross-shore sediment transport and for evaluating hydraulic processes in inlets and other restricted waterways. Currents, which are generated by a variety of mechanisms, vary greatly spatially and temporally in both magnitude and direction. Four general classes of unidirectional flow affect coastal environments and produce geologic changes. These include:

- Nearshore wave-induced currents, including longshore and rip currents.
- Flow in tidal channels and inlets, which typically changes direction diurnally or semidiurnally, depending on the type of tide along the adjacent coast.
- River discharge.
- Oceanic currents, which flow along continental land masses.

This section will briefly discuss the first two of these topics and present data examples. The third and fourth are beyond the scope of this report, and the reader is referred to outside references for additional information.

Nearshore wave-induced currents

In theory, one of the main purposes for measuring nearshore, wave-induced currents is to estimate longshore transport of sediments. At the present level of technology and mathematical knowledge of the physics of sediment transport, the direct long-term measurement of longshore currents by gages is impractical. Two main reasons account for this situation. First, as discussed earlier in this report, deployment, use, and maintenance of instruments in the nearshore and the surf zone are difficult and costly. Second, the mechanics of sediment transport are still little understood, and no one mathematical procedure is yet accepted as the definitive method to calculate sediment transport, even when currents, grain size, topography, and other

parameters are known. An additional consideration is how to monitor the variation of current flow across and along the surf zone. Because of the extreme difficulty of obtaining data from the surf zone, neither the cross-shore variations of currents nor the temporal changes in longshore currents are well known.

Longshore (or littoral) drift is defined as: "Material (such as shingle, gravel, sand, or shell fragments) that is moved along the shore by a littoral current" (Bates and Jackson 1984). Net longshore drift refers to the difference between the volume of material moving in one direction along the coast and that moving in the opposite direction (Bascom 1964). Along most coasts, longshore currents change directions throughout the year. In some areas, changes occur in cycles of a few days, while in others the cycles may be seasonal. Therefore, one difficulty in determining net drift is defining a pertinent time frame. Net drift averaged over years or decades may conceal the fact that significant amounts of material may also flow in the opposite direction.

Because net longshore currents may vary greatly from year to year along a stretch of coastline, it would be desirable to deploy current meters at a site for several years in order to obtain the greatest amount of data possible. Unfortunately, the cost of a multi-year deployment could be prohibitive. Even a long deployment might not detect patterns which vary on decade-long scales, such as the climatic changes associated with El Niño. At a minimum, near-shore currents should be monitored at a field site for at least a year in order to assess the changes associated with the passing seasons. Coastal scientists must be aware of the limitations of field current data and recognize that long-term changes in circulation patterns may remain undetected despite the best field monitoring efforts.

Figure 37 is an example of current data from offshore Fort Walton Beach, Florida. The current directions and velocities were calculated from wave orbital velocities measured by a wave gage in the 10-m water depth, 400 m offshore. Because the gage was outside of the surf zone, the currents reflect the combined influence of tides, winds, waves, and possibly offshore influences like the Gulf of Mexico Loop Current (Morang 1992). Nevertheless, the isobaths in this area are parallel to the shore and the directions of the nearshore currents are likely to be the same as those of the longshore currents within the surf zone.

Flow in tidal channels and inlets

An inlet is "a small, narrow opening in a shoreline, through which water penetrates into the land" (Bates and Jackson 1984). Inlets range in size from short, narrow breaches in barrier islands to wide entrances of major estuaries like Chesapeake Bay. Many geologic and engineering studies concern flow through tidal inlets in sand-dominated barriers, particularly when the inlets serve as navigation channels connecting harbors to the open sea.

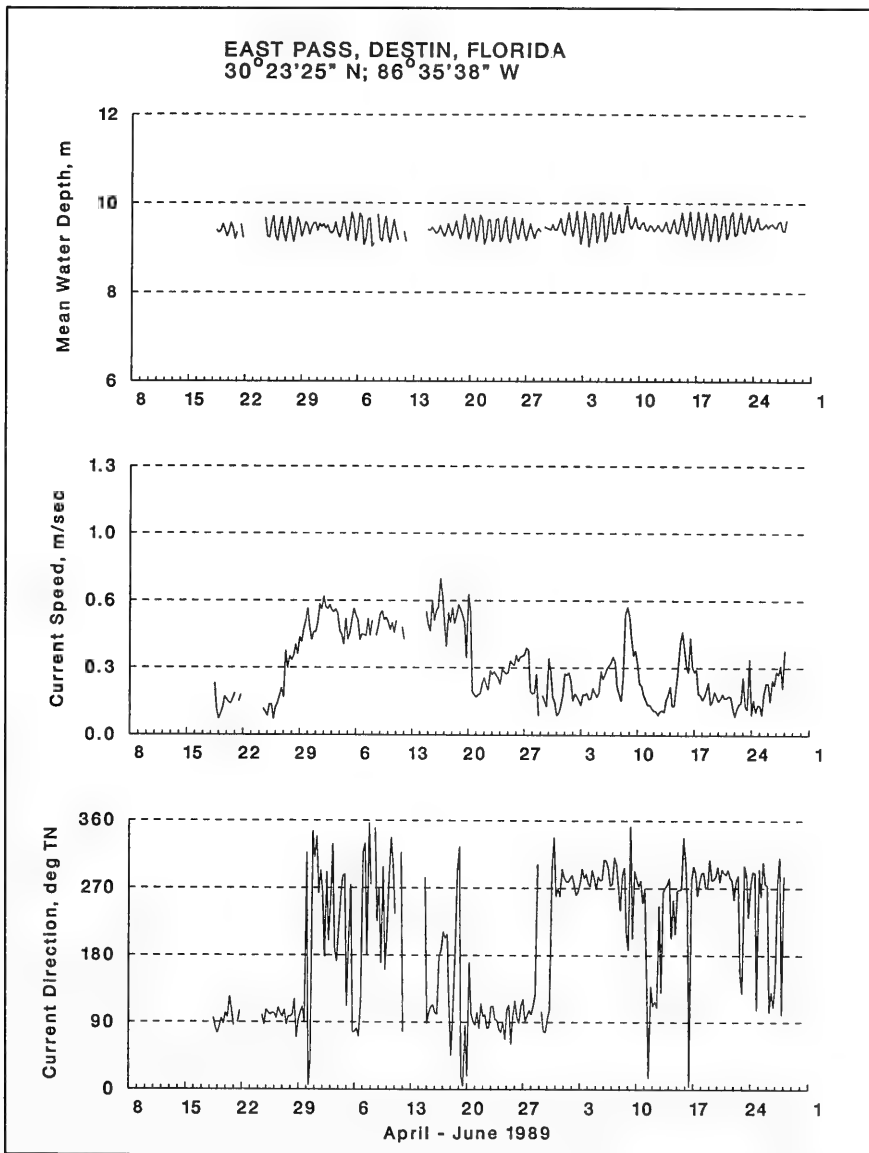

Figure 37. Coastal currents measured off Fort Walton Beach, Florida Panhandle. Note that the currents flow east or west for periods of days at a time

Inlets exchange water between the sea and the bay during each tidal cycle. Therefore, currents in tidal inlets are typically unidirectional, changing direction diurnally or semidiurnally, depending upon the tides along the adjacent open coast. Flow through the inlets can be complicated by the hydrodynamics of the inland bay, especially if there are other openings to the sea.

Various numerical and conceptual models have been developed to describe flow through inlets and allow researchers to predict the effects of changing inlet dimensions, lengths, and orientations (Aubrey and Weishar 1988; Escoffier 1977; Seelig, Harris, and Herchenroder 1977; *Shore Protection Manual* 1984). Most models, however, benefit from or require calibration with physical measurements made within the inlet and the general vicinity. The required field measurements are usually either tidal elevations from the open sea and within the adjacent bay or actual current velocities from within the inlet's throat.

Display of tidal elevation data is relatively straightforward, usually consisting of date or time on the x-axis and elevation on the y-axis. Examples of tidal elevations from a bay and an inlet in the Florida Panhandle are presented in Figure 17. Although the overall envelope of the curves is similar, each one is unique with respect to the heights of the peaks and the time lags. The curves could be superimposed to allow direct comparison, but, at least at this 1-month-long time scale, the result would be too complicated to be useful.

Display of current meter measurements is more difficult because of the large quantity of data usually collected. An added difficulty is posed by the changing currents within an inlet, which require a three-dimensional representation of the flow, which varies with time. Current measurements from East Pass, Florida, collected during three field experiments in the mid-1980's, are presented as examples. Currents were measured with manual Price-type AA meters deployed from boats and with tethered Endeco 174 current meters. The manual measurements were made hourly for 24 hr in order to observe a complete tidal cycle. The measurements were made across the inlet at four stations, each one consisting of a near-surface, a mid-depth, and a near-bottom observation (Figure 38). Therefore, 12 direction and velocity data values were obtained at each hour (Figure 39). One way to graphically display these values is to plot the velocities on a plan view of the physical setting, as shown in Figure 38. This type of image clearly shows the directions and relative magnitudes of the currents. In this example, the data reveal that the currents flow in opposite directions in the opposite halves of the inlet. The disadvantage of the plan view is that it is an instantaneous snapshot of the currents, and the viewer cannot follow the changes in current directions and magnitudes over time unless the figure is redrawn for each time increment. Temporal changes of the currents can be shown on dual plots of magnitude and direction (Figure 40). Unfortunately, to avoid complexity, it is not reasonable to plot the data from all 12 measurement locations on a single page. Therefore, measurements from the same depth are plotted together, as

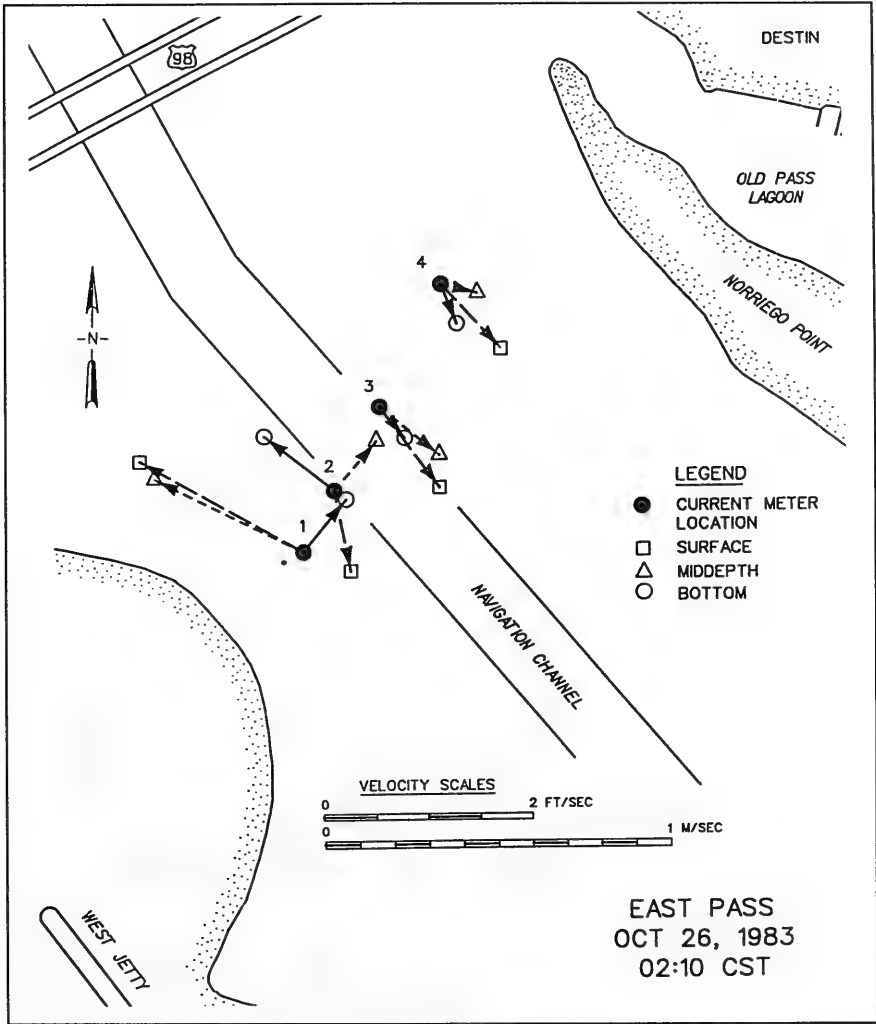

Figure 38. Current measurement stations in East Pass Inlet, Destin, Florida, during October, 1983. Measurements were made hourly from small boats. At 02:10 CST, currents were flowing to the northwest along the west side of the inlet and to the southeast along the center and east sides of the inlet. Station 2 was in the mixing zone

DESTIN (EAST PASS) TIDE STUDY

U.S. ARMY ENGINEER DISTRICT MOBILE

Project DESTIN TIDE STUDY	Date 260083	Page of 12	Pages
Boat SKI BARGE	Meter No. PRICE TYPE STANDARD	Dir. Ind. No. WES 23	
Observers JAB	JHL	JTM	
Range EAST PASS SOUTH OF US 98 BRIDGE STARTED @ STATION # 1 @ BEACON # 9 (WEST TO EAST)			

* DST = DAYLIGHT SAVING TIME / SUBTRACT ONE HOUR FOR STANDARD TIME

Sta No.	* Military Time	Feet Below Surface	Current			Remarks	Sta No.	* Military Time	Feet Below Surface	Current				
			Dir Mag	Rev Time	Velocity Ft/Sec					Dir Mag	Rev Time	Velocity Ft/Sec		
1	0200	2 S	4.16	135	20/49	1.910	ANCHOR WINDY CHOPPY SEAS FLOOD TIDE	1	C302	S	3.80	EBB 122	20/48	1.84
		M	10.4	150	20/50	1.892				M	9.56	EBB 120	20/49	1.80
		B	16.6 20.8	128	20/64	1.701				B	15.4 19.2	EBB 220	20/45	1.989
2	0206	S	4.16	128	30/50	1.33	ANCHOR WINDY CHOPPY SEAS FLOOD TIDE	2	0307	S	3.62	EBB 350	20/51	1.815
		M	10.4	125	20/42	1.06				M	9.20	EBB 230	20/51	1.875
		B	16.6 20.8	150	20/42	1.06				B	14.3 18.4	FLOOD 130	20/42	1.06
3	0211	S	2.44	120	30/42	1.58	ANCHOR WINDY CHOPPY SEAS FLOOD TIDE	3	C321	S	2.40	EBB 325	20/47	1.948
		M	6.10	120	30/42	1.58				M	6.00	EBB 310	20/50	1.892
		B	8.9 12.2	118	30/41	1.62				B	9.2 12.1	EBB 320	20/64	1.701
4	0216	S	2.92	122	30/50	1.33	ANCHOR WINDY CHOPPY SEAS FLOOD TIDE	4	0326	S	2.92	EBB 320	20/49	1.910
		M	7.30	125	30/51	1.30				M	7.30	EBB 245	10/41	1.552
		B	11.1 14.6	122	20/43	1.03				B	11.1 14.6	EBB 340	20/62	1.723
	S							S						
	M							M						
	B							B						
	S							S						
	M							M						
	B							B						

Figure 39. Example of hand-written field notes listing times and data values of East Pass current measurements. The data are presented efficiently but are difficult to visualize

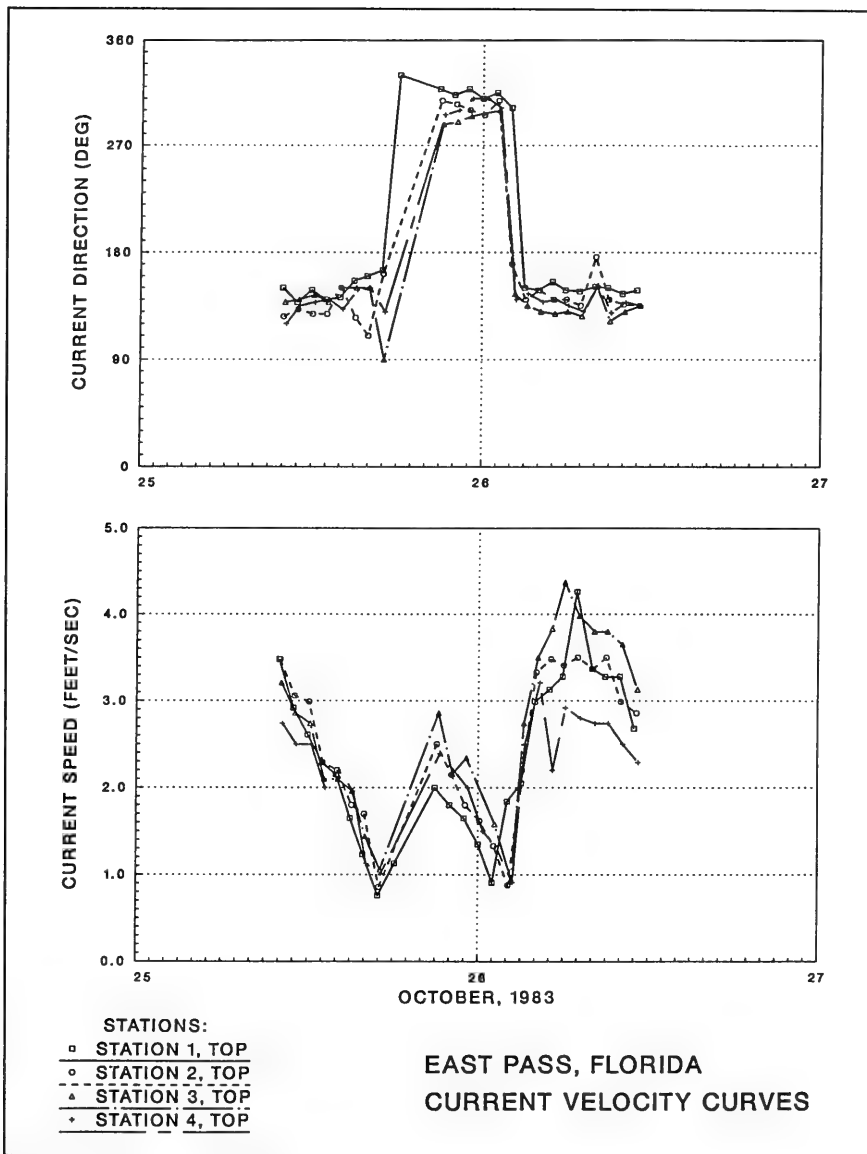

Figure 40. Time series plots of current speed (bottom) and direction (top)

in Figure 40, or all measurements from one site can be plotted together (top, middle, and bottom).

In summary, current data can be displayed in the form of instantaneous snapshots of the current vectors or as time series curves of individual stations. Many plots are usually needed to display the data collected from even short field projects. It may be advantageous to present these plots in a data appendix rather than within the text of a report.

Error analysis of current data

Error analysis of current records can be broadly divided into two categories. The first concerns calibrations of the actual current sensing instruments. A user needs to know how closely the numbers reported by a particular instrument represent the water motions that it is purported to be measuring. This information is important for both evaluation of existing data sets and for planning of new field experiments, where some instruments may be more suitable than others.

The second broad question pertains to whether the measurements that have been gathered adequately represent the flow field in the inlet or channel that is being examined. This second problem is exceedingly difficult to evaluate because it raises the fundamental questions of "How much data do I need"; and, "Can I afford to collect the data that will really answer my questions?" The user is typically tempted to respond that he wants just as much data as possible, but this may prove to be counterproductive. For example, if the currents in an inlet are being measured to determine variations in the tidal prism over time, will a dense gridwork of sampling stations in an inlet provide more useful data? Or might the excess data reveal unnecessary details about turbulence and mixing in the inlet? These are intrinsically interesting questions, but may not be germane to the engineering problems that must be addressed. Although the dense grid pattern of data can be used to evaluate overall flow, the collection, analysis, and management of the excess data can be costly and time-consuming. The money used on management of this data might be better spent extending a simpler sampling program for a longer period at the site.

Possibly a statistical approach could be used to plan the placement of instruments in an inlet. In order to plan the optimum deployment of current meters in the 1973 North Atlantic Mid Ocean Dynamics Experiment (MODE-73), Bretherton, Davis, and Fandry (1976) applied the Gauss-Markov theorem to minimize the expected interpolation error between instruments and map the expected error. These errors depended upon the statistics of the field array and not upon the measurements themselves. Wunsch (1978) and Wunsch and Minster (1982) used inverse theory to determine the circulation of the Atlantic Ocean by modeling the conservation of various properties and then comparing the resulting models to the flow field actually measured by instruments. They concluded that there were serious shortcomings to the

oceanic data set and that, despite the efforts that had gone into North Atlantic hydrography over the last 100 years, the true general circulation was still unknown. Applying inverse theory to model instrument deployment in shallow water and to estimate, before the actual deployment, what types and magnitudes of errors can be expected, promises to be a fruitful line of research. The results may show that fewer instruments will suffice, providing a significant cost savings. On the other hand, the results may reveal that flow in inlets continues to be an under-determined problem and that past instrument practices have been inadequate to define the flow field.

Analysis of error from various types of current sensors has been the subject of extensive study in the last 30 years. Numerous types of error can occur, both during field deployment of the instrument and during data processing. These can result from instrument calibration, clock time errors, and data recording and playback. In addition, the user is cautioned that each of the many types and brands of current meters is capable of recording accurately only a segment of the spectrum of water motions because of the influence of the mooring assembly, type of velocity sensor used, and recording scheme of the instrument (Halpern 1980). Halpern's (1980) paper lists many references that discuss tests of moored current meters.

Manufacturers of current meters publish accuracy standards in their literature. These standards may be optimistic, especially under the adverse conditions encountered in many coastal settings. In addition, the type of mooring used for the instrument affects the quality of the measured data (Halpern 1978). For these reasons, the user of existing data is urged to obtain as much information as possible regarding the specifics of the deployment and the type of mooring in order to try to assess the accuracy of the results. Ultimately, successful use of current gages is critically dependent upon the planning of the experiment and upon the care and skill of the technicians who maintain and deploy the instruments.

River discharge

River outflow has a major effect on some coastlines, particularly where massive deltas have formed (e.g. Mississippi, Nile, Niger, Ganges, Mekong, Indus, Irriwadi Deltas). Even if a study area is not located on a delta, coastal researchers must be aware of the potential impact of rivers on coastal processes, especially if the study region is affected by freshwater runoff at certain seasons or if longshore currents carry river-derived sediment along the shore.

The physics of unidirectional flow in rivers has been extensively studied for more than a century. It is beyond the scope of this report to discuss the mechanics and procedures of current measurement in rivers, and the reader is referred to texts on hydraulic engineering for methods and additional details. An introduction to riverine hydraulics is provided in Linsley and Kohler (1982). Calculation of river discharge is reviewed in HQUSACE (1959,

1987). Graf (1984), Middleton and Southard (1984), and Vanoni (1975) review general concepts of sediment transport and fluid-particle interactions in rivers, and 15 excellent papers on hydraulic processes and primary sedimentary structures are reprinted in Middleton (1977). Deltaic and estuarine sedimentation and structures are reviewed in Boggs (1987), Nichols and Biggs (1985), and Wright (1985).

River discharge data are available for many coastal rivers. A cursory examination of the annual hydrograph will reveal the seasonal extremes. Because of the episodic nature of coastal flooding, annual discharge figures may be misleading. A useful parameter to estimate river influence on the coast is the hydrographic ratio (H_R), which compares tidal prism volume with fluvial discharge volume (Peterson et al. 1984).

Oceanic currents

Major oceanic currents intrude onto some continental shelves with enough bottom velocity to transport sandy sediments. The currents operate most effectively on the outer shelf, where they may transport significant volumes of fine-grained sediments but presumably contribute little if any new sediment (Boggs 1987). Along most coastlines, ocean currents have little direct effect on shoreline sedimentation or erosion. Even off southeast Florida, where the continental shelf is narrow, the western edge of the Gulf Stream flows at least 1/2 km offshore. However, in some locations where currents approach the coastal zone, sediment discharged from rivers is transported and dispersed along the adjacent coastline. This process may arrest the seaward progradation of the delta front while causing extensive accumulations of riverine-derived clastics downdrift of the river mouth (Wright 1985). The most prominent example of this phenomenon is the Amazon River mouth, where the Guiana current carries Amazon sediments hundreds of kilometres to the northwest (Wright 1985). The same current also disperses sediment from the Rio Orinoco.

In shallow carbonate environments, reefs thrive where currents supply clean, fresh ocean water. Reefs stabilize the bottom, provide habitat for marine life, produce carbonate sediments, and sometimes protect the adjoining shore from direct wave attack (i.e., the Great Barrier Reef of Australia). In the United States, live reefs are found in the Gulf of Mexico off Texas and west Florida and in the Atlantic off Florida. Coral islands are found in the Pacific in the United States Trust Territories. For geologic or engineering studies in these environments, there may be occasional need to monitor currents. Procedures of deepwater current measurement are presented in Appell and Curtin (1990) and McCullough (1980).

In summary, the effect of tide or wave-induced currents is likely to be much more important to most coastal processes than ocean currents. Measurement of ocean currents may occasionally be necessary for geologic studies in deltaic or carbonate environments.

Maps and Photographs

Introduction

Maps and aerial photographs can provide a wealth of useful information for the interpretation of geologic coastal processes and evolution. Maps and photographs can reveal details on:

- Long-term and short-term advance or retreat of the shore.
- Longshore movement of sediments.
- The impact of storms, including breaches of barrier islands, overwash, and changes in inlets, vegetation, and dunes.
- Problems of siltation of tidal inlets, river mouths, estuaries, and harbors.
- Human impacts caused by construction or dredging.
- Compliance with permits.
- Biological condition of wetlands and estuaries.

For example, the geometry of the coastline in the vicinity of headlands, inlets and streams, and man-made structures is one key to assessing the dispersal of the products of coastal erosion and sediments supplied by rivers (Figure 41).

Large sets of historical aerial photographs and maps have been used to interpret regional geomorphic changes of coastal South Carolina (Anders, Reed, and Meisburger 1990), northern New Jersey (Gorman, Reed, and Stauble 1993), and the Kings Bay area of Georgia and Florida (Kraus and Gorman 1993) (Figure 42). Using detailed historic data, Dolan and Hayden (1983) were able to conclude that shore processes and landforms assume systematic, as opposed to random, patterns both along and across the coast. They found that large storms caused severe erosion in the same locations as previous storms of lower intensity. Long-term erosion rates have been examined even over large areas, although the quality and distribution of historic maps is spotty (Dolan, Hayden, and May 1983). May and Britsch (1987) examined the effects of natural and human-induced wetland losses in the Mississippi Delta.

Historical shoreline change mapping

The use of maps and aerial photographs to determine historical changes in shoreline position is increasing rapidly. Analyzing existing maps does not require extensive field time or expensive equipment, and therefore often provides valuable information at an economical price. This section summarizes the interpretation of water line on photographs and maps and corrections needed to convert historic maps to contemporary projections and coordinate systems.

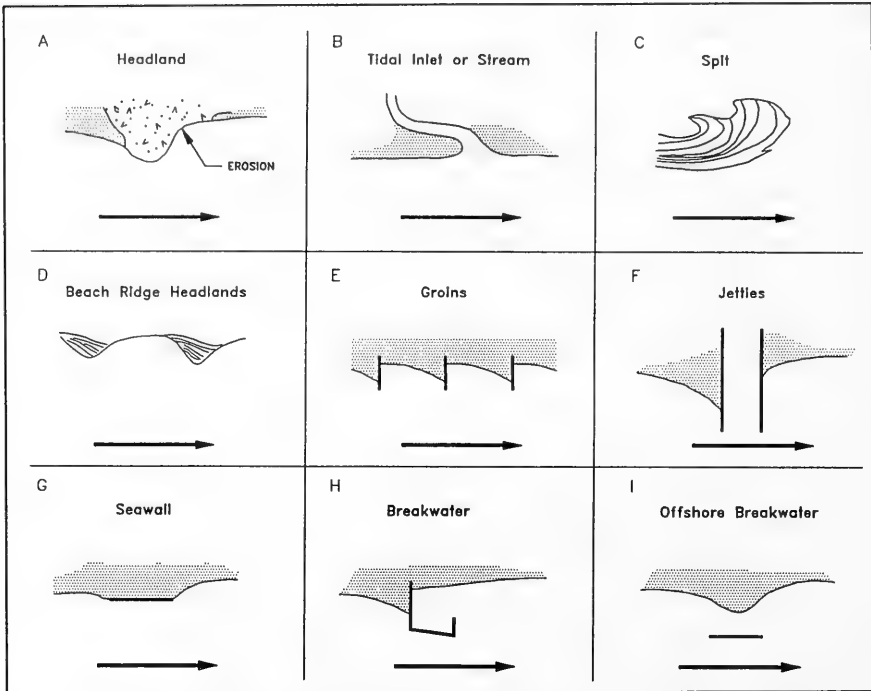

Figure 41. Morphologic indicators of littoral drift along natural and modified shorelines. Natural features such as rock headlands show accretion on the updrift side and erosion on the downdrift side (A), tidal inlets and spits show extension in a downdrift direction (B-C), and beach ridge headlands show successive growth on the updrift end influenced by the development of coastal cells which form shoreline irregularities (D). Coastal engineering structures including groin fields, jetties, seawalls, attached breakwaters, and offshore breakwaters (E-I) generally show accumulation of sediment on the updrift side, and reduced sediment supply on the downdrift side

Many possible datums can be used to monitor historical changes of the shoreline. In many situations, the high water line (HWL) has been found to be the best indicator of the land-water interface (Crowell, Leatherman, and Buckley 1991). The HWL is easily recognizable in the field and can usually be approximated from aerial photographs by a change in color or shade of the beach sand. The datum printed on the NOS T-sheets is listed as "Mean High Water." Fortunately, the early NOS topographers approximated HWL during their survey procedures. Therefore, direct comparisons between historical T-sheets and modern aerial photographs are possible. In order to calculate the genuine long-term shoreline change, seasonal beach width variations and other

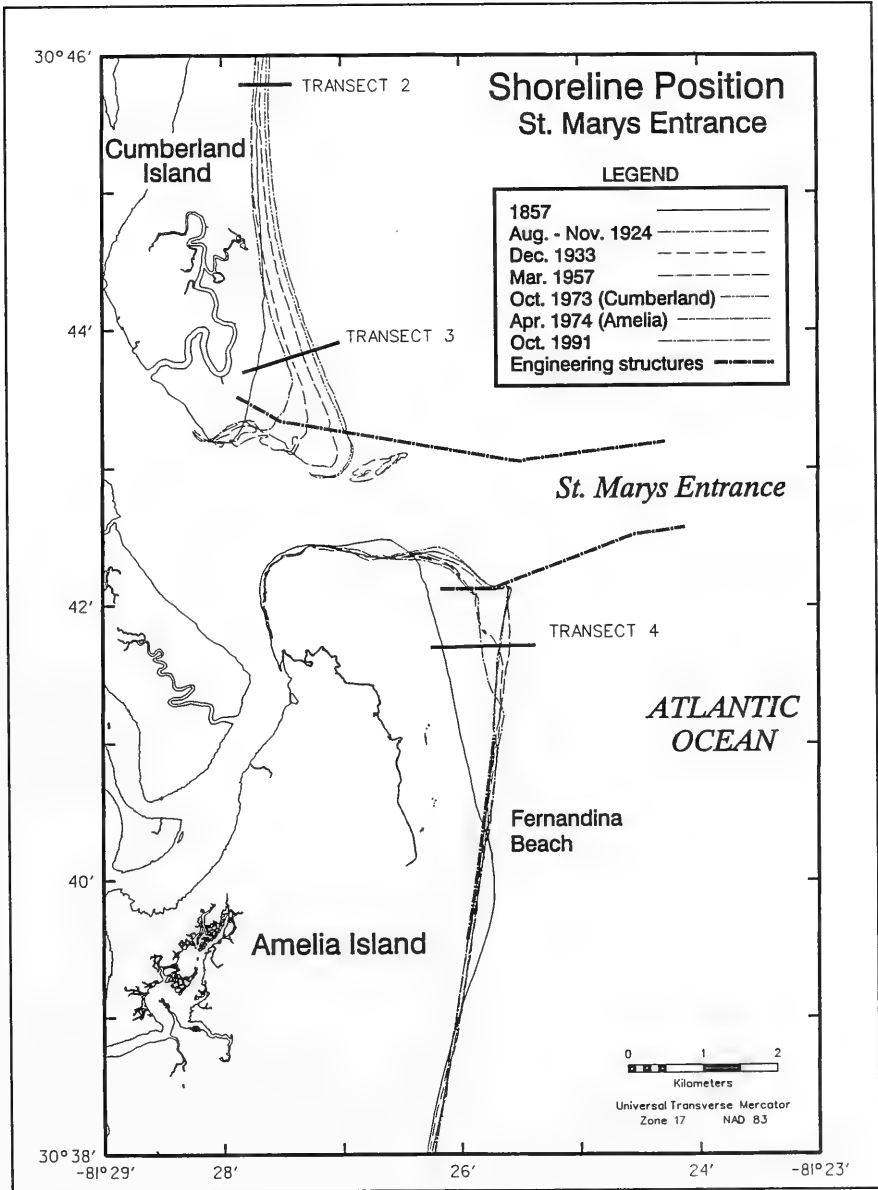

Figure 42. Changes in shoreline position near St. Marys entrance, Florida-Georgia (from Kraus and Gorman 1993)

short-term changes should be filtered out of the record. The best approach is to use only maps and aerial images from the same season, preferably summertime.

A crucial problem underlying the analysis of all historical maps is that they must be corrected to reflect a common datum and brought to a common scale, projection, and coordinate system before data from successive maps can be compared (Anders and Byrnes 1991). Maps made before 1927 have an obsolete latitude-longitude coordinate system (U.S. datum or North American (NA) datum) that must be updated to the current standard of NAD 1927 or the more recent NAD 1983. To align maps to a specific coordinate system, a number of stable and permanent points or features must be identified for which accurate and current geographic coordinates are known. These locations, called primary control points, are used by computer mapping programs to calculate the transformations necessary to change the map's projection and scale. The most suitable control points are triangulation stations whose current coordinates are available from the National Geodetic Survey.

Maps that were originally printed on paper have been subjected to varying amounts of shrinkage. The problem is particularly difficult to correct if the shrinkage along the paper's grain is different than across the grain. Maps with this problem have to be rectified or discarded. In addition, tears, creases, and folds in the paper maps must be corrected.

Aerial photographs, which are not map projections, must be corrected by optical or computerized methods before shore positions compiled from the photos can be directly compared with those plotted on maps. The distortion correction procedures are involved because photos do not contain defined control points like latitude-longitude marks or triangulation stations. On many images, however, secondary control points can be obtained by matching prominent features such as the corners of buildings or road intersections with their mapped counterparts (Crowell, Leatherman, and Buckley 1991). Types of distortion which must be corrected include:

- Tilt. Almost all vertical aerial photographs are tilted with 1 deg being common and 3 deg not unusual (Lillesand and Kiefer 1987). The scale across tilted air photos is non-orthogonal, resulting in gross displacement of features depending upon the degree of tilt.
- Variable scale. Planes are unable to fly at a constant altitude. Therefore, each photograph in a series varies in scale. A zoom transfer scope can be used to remove scale differences between photos.
- Relief displacement. Surfaces which rise above the average land elevation are displaced outward from the photo isocenter. Fortunately, most U.S. coastal areas, especially the Atlantic and Gulf barriers, are relatively flat and distortion caused by relief displacement is minimal.

However, when digitizing cliffed shorelines, control points at about the same elevation as the feature being digitized must be selected.

- Radial lens distortion. With older aerial lenses, distortion varied as a function of distance from the photo isocenter. It is impossible to correct for these distortions without knowing the make and model of the lens used for the exposures (Crowell, Leatherman, and Buckley 1991). If overlapping images are available, digitizing the centers, where distortion is least, can minimize the problems.

Fortunately, most errors and inaccuracies from photographic distortion and planimetric conversion can be quantified. Past shoreline mapping exercises have shown that if care is taken in all stages of filtering original data sources, digitizing data, and performing distortion corrections, the resulting maps meet, and often exceed, National Map Accuracy Standards (Crowell, Leatherman, and Buckley 1991).

Topographic and Bathymetric Data

Introduction

The analysis and examination of topographic and bathymetric data are fundamental in many studies of coastal engineering and geology. When assembling bathymetric surveys from a coastal area, a researcher is often confronted with an immense amount of data that must be sorted, checked for errors, redisplayed at a common scale, and compared year by year or survey by survey in order to detect whether changes in bottom configuration have occurred. This section will discuss three general aspects of geographic data analysis:

- Processing of bathymetric data using mapping software.
- Applications and display of the processed results.
- Error analyses.

Bathymetric data processing - data preparation and input

Most historical bathymetric data sets consist of paper maps with printed or hand-written depth notations (Figure 43). Occasionally, these data are available on magnetic media from agencies like NOAA, but often a researcher must first digitize the maps in order to be able to perform computer-based processing and plotting. If only a very limited region is being examined, it may be more expedient to contour the charts by hand. The disadvantage of hand-contouring is that it is a subjective procedure. Therefore, one person should be responsible for all the contouring in order to minimize variations

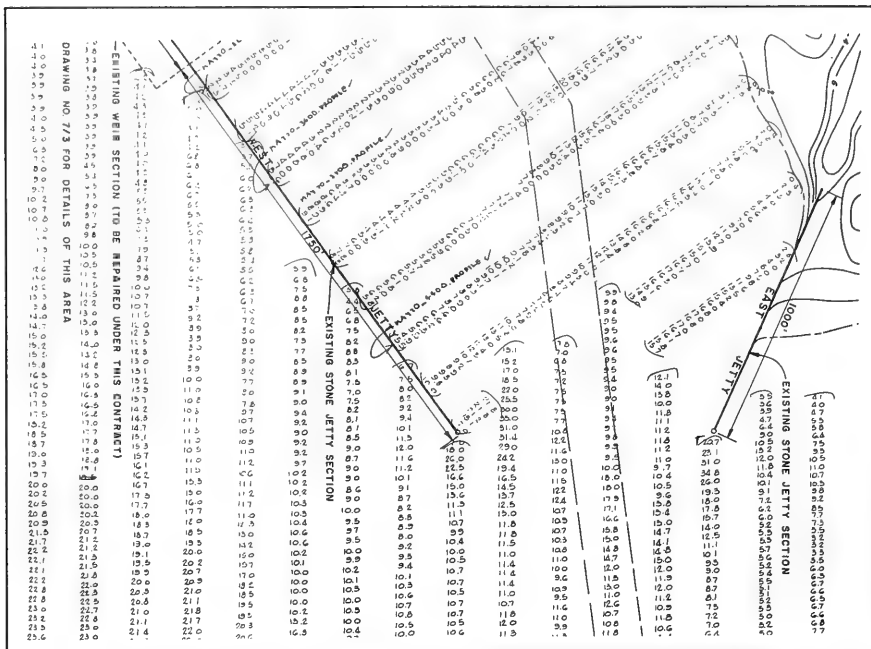

Figure 43. Example of a hand-annotated hydrographic map from a Florida project site. The depths have been corrected for tide and are referenced to mlw. (Map courtesy of USAE District, Mobile)

caused by different drawing styles or methods of smoothing topographic variations.

In order to be able to manipulate three-dimensional (X, Y, and Z) data, display and plot it at different scales, and compare different data sets, it is necessary to use one of the commercial mapping programs such as Radian Corporation's Contour Plotting System 3 (CPS-3) or Golden Software's Surfer. These are comprehensive packages of file manipulation, mapping algorithms, contouring, and two- and three-dimensional display. Their use requires considerable training, but they are powerful analysis tools.

The raw data used by mapping programs consist of data in X-Y-Z form. As described in the previous section, if the data are derived from old maps, they must first be corrected to a common datum, map projection, and coordinate system. For small files, visual examination of the data may be worthwhile in order to inspect for obviously incorrect values. Because it is laborious to review thousands of data points, simple programs can be written to check the raw data. For example, if all the depths in an area are expected to be between +5.0 and -40.0 ft, the program can tag depths that are outside

this range. The analyst can then determine if questionable points are erroneous or represent genuine but unexpected topography. The X and Y points should typically represent Cartesian coordinates, which is the case if the original maps were based on State Plane coordinates. X and Y points that are latitude and longitude must be converted by the program.

Gridding operations

Gridding is a mathematical process in which a continuous surface is computed from a set of randomly distributed X, Y, and Z data¹. The result of the gridding operation is a data structure (usually a surface) called a grid. Note that the grid is an artificial structure. It is based on the original data (and hopefully is an accurate representation of the topography which was surveyed in the field), but the grid points are not identical with the original survey points (Figures 44 and 45). Because the grid represents the surface that is being modeled, the accuracy of the grid directly affects the quality of any output based on it or on comparisons with other grids generated from other data sets. Computing a grid is necessary before operations such as contouring, volume calculation, profile generation, or volume comparison can be performed. The advantage of a grid is that it allows the program to manipulate the surface at any scale or orientation. For example, profiles can be generated across a channel even if the original survey lines were not run in these locations. In addition, profiles from subsequent surveys can be directly compared, even if the survey track lines were very different.

Several steps must be considered as part of the grid generation. These include:

- Selecting a gridding algorithm.
- Identifying the input data.
- Specifying the limits of the grid coverage.
- Specifying gridding parameters.
- Specifying gridding constraints.
- Computing the grid.

The choice of a gridding algorithm can have a major effect on the ultimate appearance of the grid. Software companies have proprietary algorithms which they claim are universally superior. Often, however, the type or distribution of data determines which procedure to use, and some trial and error is necessary at the beginning of a project. Because a computed grid is an artificial structure, often it is a subjective evaluation whether one grid is "better" than another. For subaerial topography, an oblique aerial photograph can be compared with a computer-generated three-dimensional drawing oriented at the same azimuth and angle. But for a subaqueous seafloor, other than

¹ Material in this section has been condensed from course notes provided by Radian Corporation during a CPS-3 training seminar presented at CERC in November 1989.

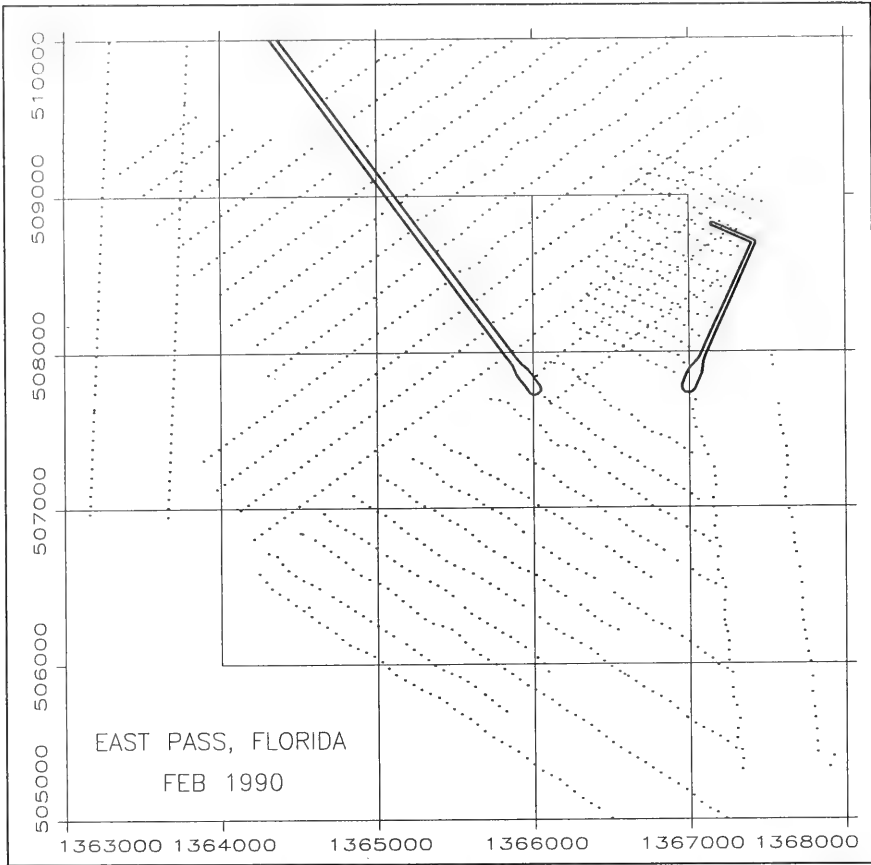

Figure 44. Digitally collected hydrographic data from a Florida project site. The track lines are obvious, as is the fact that the soundings are not uniformly distributed throughout the survey area. (Data courtesy of USAE District, Mobile)

comparing a gridded surface with a hand-contoured chart, how can a researcher really state that one surface does not look right while another does?

The fundamental challenge of a gridding algorithm is to estimate depth values in regions of sparse data. The procedure must attempt to create a surface that follows the trend of the terrain as demonstrated in the areas where data do exist. In effect, this is similar to the trend-estimating that a human performs when he contours bathymetric data by hand. The other challenge occurs in complex, densely sampled terrains. The algorithm must fit the surface over many points, but genuine topographic relief must not be

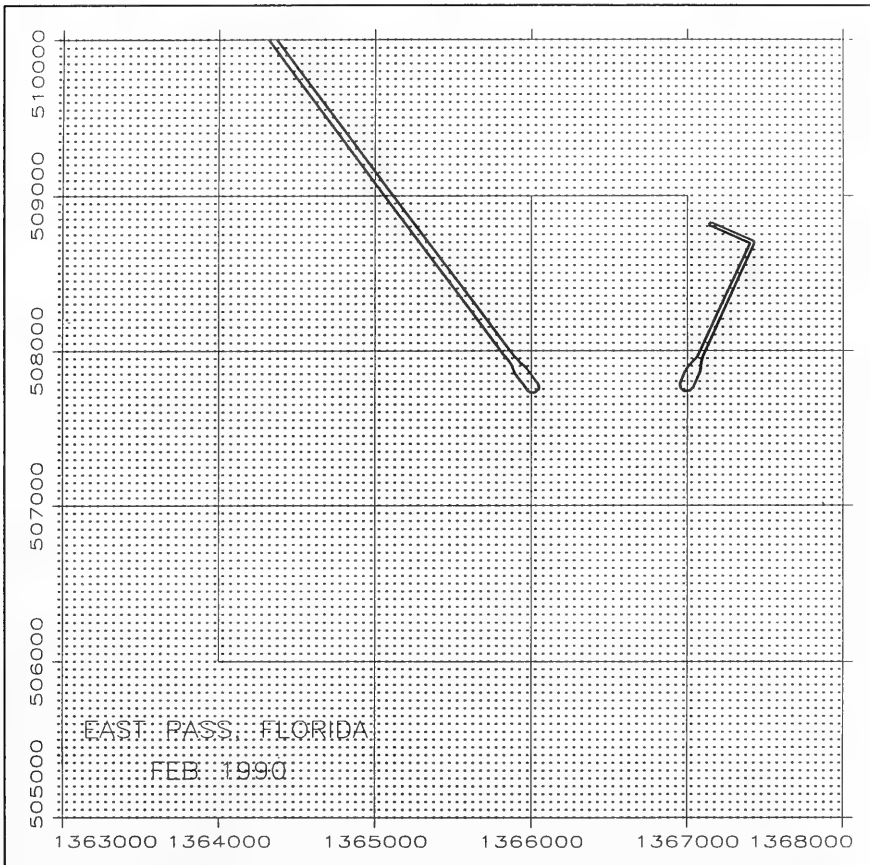

Figure 45. Surface grid computed by CPS-3 based on the data shown in Figure 44. The nodes are uniformly spaced compared with the locations of the original soundings. A grid does not necessarily have to be square, although this is common

smoothed away! Along a rocky coast, for example, high pinnacles may indeed project above the surrounding seafloor.

The gridding algorithms in CPS-3 include:

- Convergent (multi-snap).
- Least squares with smoothing.
- Moving average.
- Trend.
- Polynomial.

The convergent procedure often works well for bathymetric data. It uses multiple data points as controls for calculating the values at nearby nodes. The values are blended with a distance-weighting technique such that close points have more influence over the node than distant points. Several iterations are made, with the first being crude and including many points, and the final being confined to the closest points. The least-squares method produces a plane that fits across several points near the node. Once the plane has been calculated, the Z-value at the node is easily computed. The reader must consult software manuals to learn the intricacies of how these and other algorithms have been implemented.

Another important parameter that must be chosen is the gridding increment. This is partly determined by the algorithm chosen and also by the data spacing. For example, if survey lines are far apart, there is little purpose in specifying closely spaced nodes because of the low confidence that can be assigned to the nodes located far from soundings. In contrast, when the original data are closely spaced, large X- and Y-increments result in an artificially smoothed surface because too many data points influence each node. Some programs, such as CPS-3, can automatically calculate increments that produce good results for a wide variety of survey patterns.

Applications and display of gridded data

Contouring of an area is one of the most common applications of mapping software (Figure 46). Not only is this faster than hand-contouring, but the results are uniform in style across the area and precision (i.e. repeatability) is vastly superior.

The power of mapping programs is best demonstrated when analyzing different surveys. If at all possible, the different data sets should be gridded with the same algorithms and parameters in order that the results be as comparable as possible. Difficulty arises if earlier surveys contain data much sparser than later surveys. Under these circumstances, it is probably best if the optimum grid is chosen for each data set; the grid produced for the densely sampled survey should not be compromised just to maintain uniformity with an earlier survey. A simple application is to plot a suitable contour to demonstrate the growth over time of a feature like a shoal (Figure 47). Computation of volumetric changes over time is another application (Figure 48). This can graphically demonstrate how shoals develop or channels migrate.

Volumetric data can be used to estimate growth rates of features like shoals. As an example, using all 18 of the 1,000-ft squares shown in Figure 47, the overall change in volume of the East Pass ebb-tidal shoal between 1967 and 1990 was only 19 percent (Figure 49). Although the shoal had clearly grown to the southwest, the minor overall increase in volume suggests that considerable sand may have eroded from the inner portions of the shoal. In contrast, when plotting the change in volume of nine selected

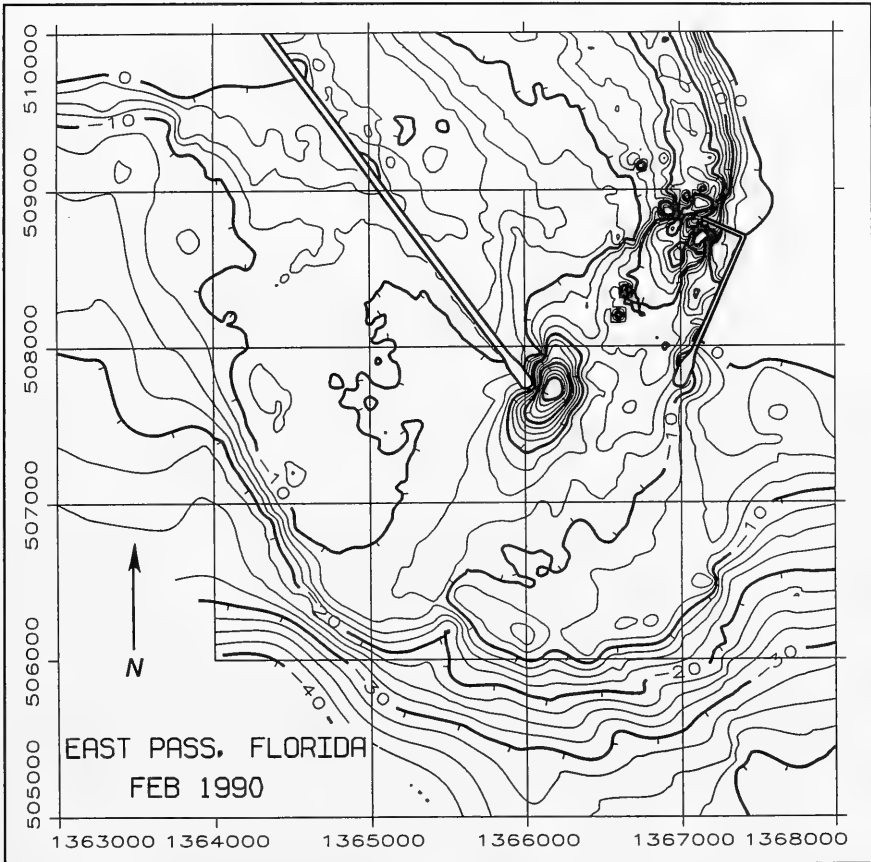

Figure 46. Contoured bathymetry of the same area shown in Figures 44 and 45

squares, the growth over time was 600 percent. This underscores how critically numerical values such as growth rates depend upon the boundaries of the areas used in the calculations. The user of secondary data beware!

Error analysis of gridded bathymetry

A crucial question is how much confidence can a researcher place on growth rates which are based on bathymetric or topographic data? Unfortunately, in the past, many researchers ignored or conveniently overlooked the possibility that error bars may have been greater than calculated trends, particularly if volumetric computations were based on data of questionable quality.

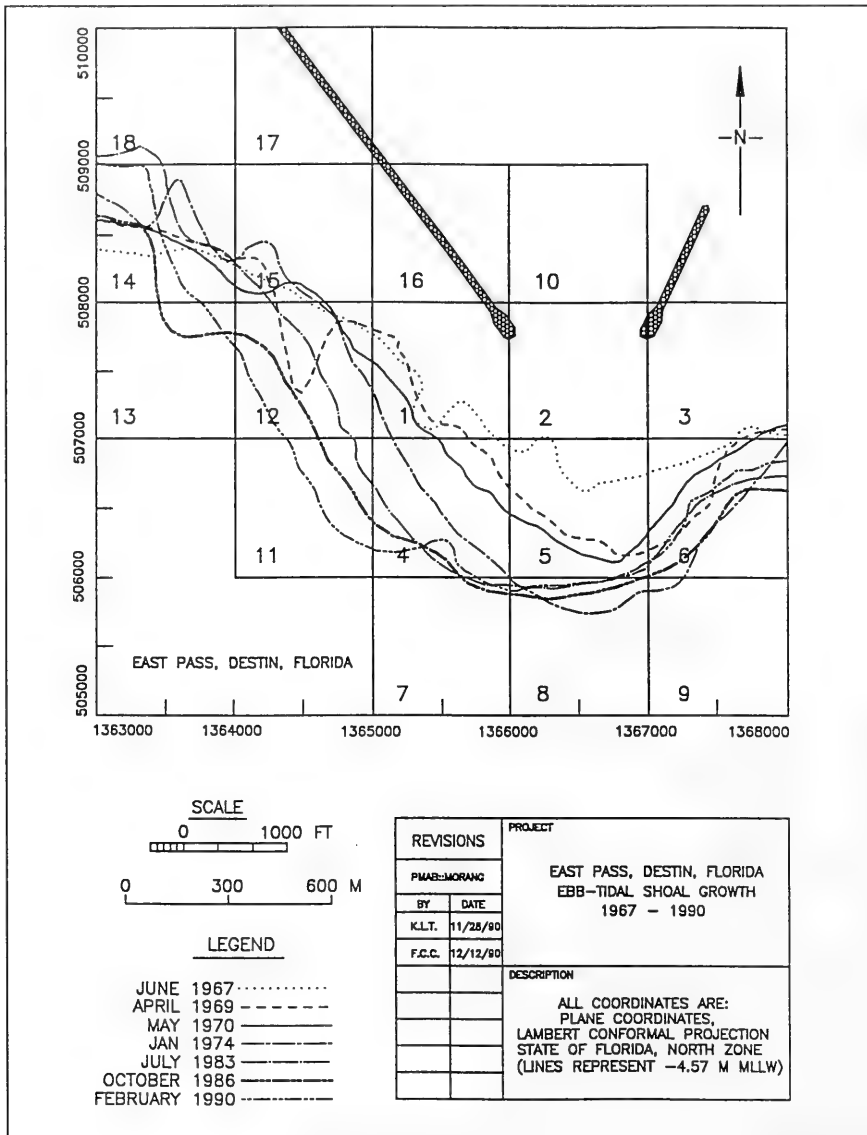

Figure 47. Overall growth of an ebb-tidal shoal over 24 years is shown by the advance of the 15-ft isobath. This isobath was chosen because it represented approximately the mid-depth of the bar front. The 1,000-ft squares are polygons used for volumetric computations

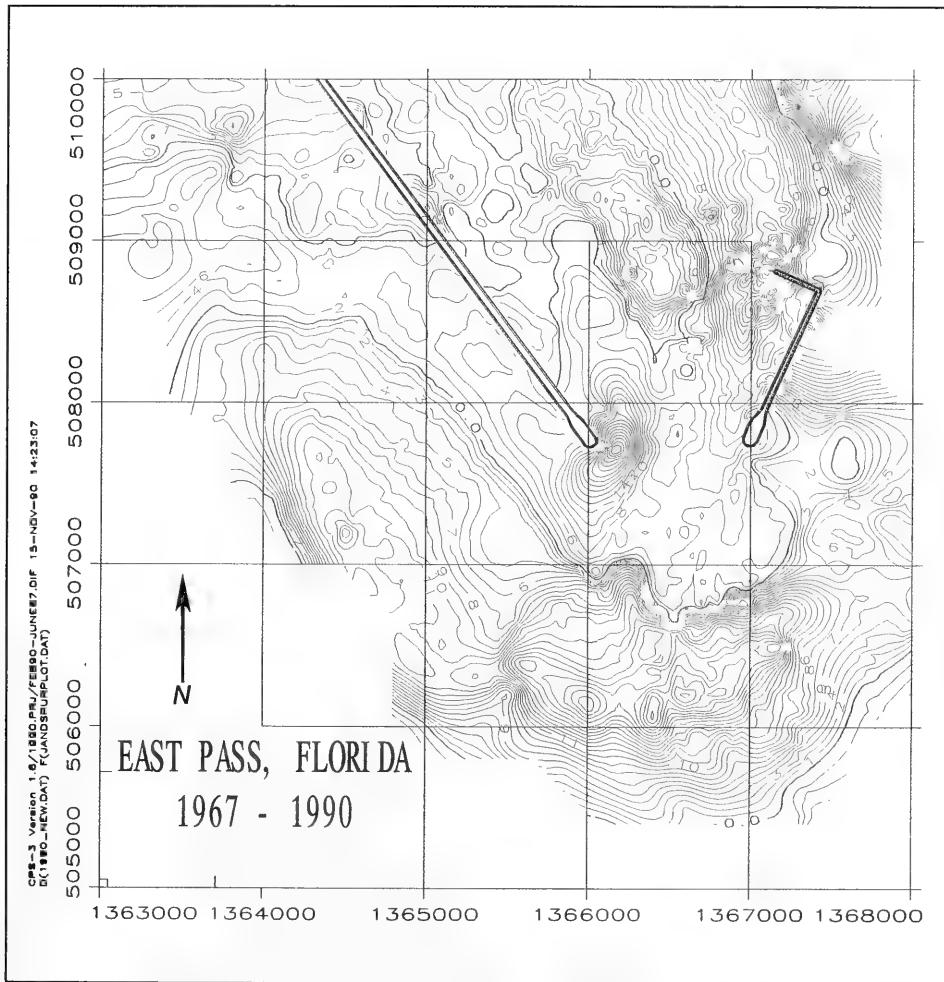

Figure 48. Isopach map showing overall changes in bottom configuration between 1967 and 1990 at East Pass, Florida. Red contours (2-ft interval) represent erosion, while green (1-ft interval) represent deposition. The migration of the channel thalweg to the east is obvious, as is the growth of scour holes at the jetties. Map computed by subtracting June 1967 surface from February 1990 surface. (Original bathymetric data courtesy of Mobile District)

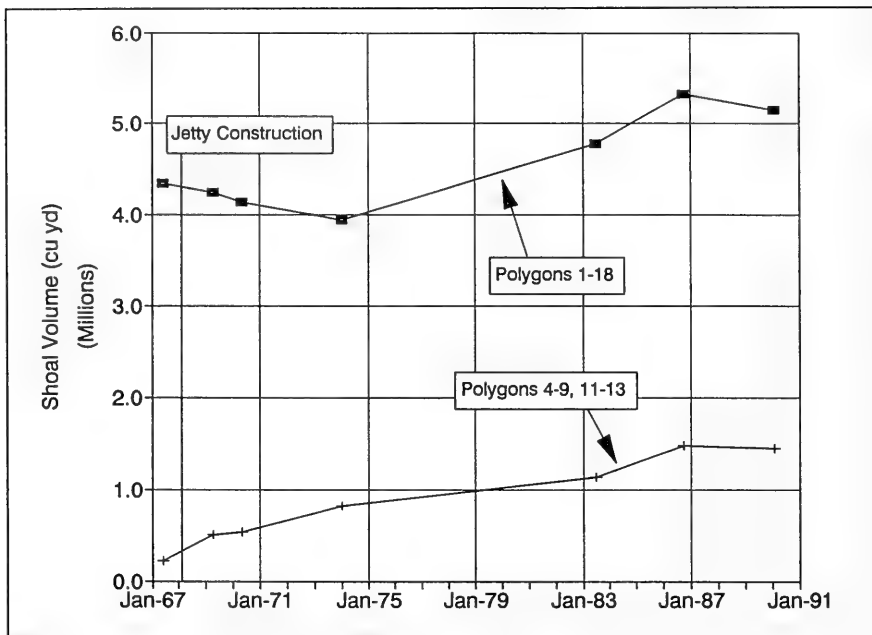

Figure 49. Growth of the ebb-tidal shoal at East Pass, FL. Areas used in the computations are shown in Figure 47. Growth rates are dramatically different depending upon which polygons are included in the volumetric computations

This section outlines a basic procedure that can be used to calculate volumetric errors, provided that estimates of vertical (ΔZ) accuracy are available. If ΔZ values are unavailable for the specific surveys, standard errors of ± 0.5 , ± 1.0 , or ± 1.5 ft, based on the class of the survey, can be used (Table 6). For coastal surveys close to shore, this method assumes that errors in positioning (ΔX and ΔY) are random and have an insignificant effect on the volumes compared with possible systematic errors in water depth measurements, tide correction, and data reduction. For older historic surveys, positioning error may be important, requiring a much more complicated analysis procedure. Positioning accuracy of hydrographic surveys is discussed in HQUSACE (1991) and NOAA (1976).

The error in volumetric difference between surveys can be estimated by determining how much the average depth in each polygon changes from one survey to another and then calculating an average depth change over all polygons. Maximum likely error (MLE) is:

$$\frac{2 \times \Delta Z}{\Delta Z(\text{ave})}$$

For example, if $\Delta Z = 0.15$ m and $\Delta Z(\text{ave}) = 0.94$ m, then MLE is:

$$\frac{0.30 \text{ m}}{0.94 \text{ m}} = 0.32 = 32 \text{ percent}$$

Note that this is for a Class 1 survey; many offshore surveys are not conducted under such tight specifications. If $\Delta Z = 0.46$ m, then MLE for the above example = 97 percent. Under these circumstances, it becomes meaningless to say that an area has changed in volume by a certain amount plus or minus 97 percent.

The size of the polygons used in the calculation of $\Delta Z(\text{ave})$ can influence the MLE. A particular polygon that covers a large area may average ΔZ of only 0.3 or 0.6 m, but water depths from spot to spot within the polygon may vary considerably more. Therefore, by using smaller polygons, ΔZ will typically be greater and MLE correspondingly less. However, the use of smaller polygons must be balanced against the fact that positioning errors (ΔX and ΔY) become correspondingly more significant.

More research is needed to quantify errors associated with the various types of offshore surveys and to identify how these errors are passed through computed quantities. They must not be neglected when analyzing geologic data, particularly if management or policy decisions will be based on perceived trends.

Sources of error in beach and nearshore surveys

Repetitive surveys of beach and nearshore profiles are commonly used to compute volume changes along the shoreline. Several sources of random error must be considered:

- Survey scheduling. If there is a time lag between the onshore and offshore surveys, the profiles may not join vertically because of genuine sediment changes (assuming that the mismatch is not due to incorrect tide, wave, datum, or other survey corrections).
- Seasonal changes. The profile may change seasonally because of storm or fair weather patterns. These temporary changes may mask long-term trends.
- Yearly variations. From year to year, the profile may change because of varying global climate or oceanographic conditions. Again, the long-term trend may be masked.
- Variations in regional sediment input. Unusual sediment inputs, such as a flood on a nearby river, may mask the overall trend.

A more fundamental limitation in using widely spaced profiles is that major morphological features between the survey lines are not included in the

volumetric computations. On land, the lines can usually be adjusted to accommodate unusual features. However, a major limitation of hydrographic surveys is that the operators cannot see significant morphological changes beforehand. For example, sand waves parallel to the survey track line or rock pinnacles may not be recorded, yet these features may represent a significant volume of material. In effect, these features are smoothed out of the data set. Saville and Caldwell (1953) estimated that spacing errors were much more important than measurement errors. They provided some figures and formulas for estimating these errors, although their work may need to be updated.

Coastal Data Interpretation with Numerical Models

Introduction

The use of numerical models in assessing changes in coastal geomorphology is rapidly increasing in sophistication. Models are designed to numerically simulate hydrodynamic processes or simulate sediment response on beaches, offshore, and in inlets. Specific types include models of wave refraction and longshore transport, beach profile response, coastal flooding, and shoreline change and storm-induced beach erosion (Birkemeier et al. 1987; Komar 1983; Kraus 1990). The judicious use of prototype data and models can greatly assist the understanding of coastal processes and landforms at a study site. Because models should be tested and calibrated, field data collection or mathematical simulations of waves, tides, and winds at a project site are usually required.

The advantage of tools like numerical models is that they can simulate phenomena only rarely observed, can generate complex and long-duration changes, and can incorporate judgements and measurements from many sources. The use of numerical models is a highly specialized skill, requiring training, an understanding of the underlying mathematics, and empirical ("real world") experience of coastal processes. This section summarizes types of models and introduces some of their strengths and limitations.

Types of models¹

Coastal experience / empirical models. This represents the process by which an understanding or intuitive feeling of coastal processes and geomorphology is adapted and extrapolated from a researcher's experience to a specific project. Prediction through coastal experience without the support of objective quantitative tools has many limitations, including severe subjectivity and a lack of criteria to use for optimizing projects. Complete reliance on coastal experience places the full responsibility for project decisions on the

¹ Material in this section has been summarized from Kraus (1989).

judgment of the researcher without recourse to testing the "model" with alternate tools. An empirical model is often necessary before choosing a numerical model.

Beach change numerical models. Figure 50 summarizes the time ranges and spatial coverage of numerical models used by CERC. Summaries of the capabilities of the models follow:

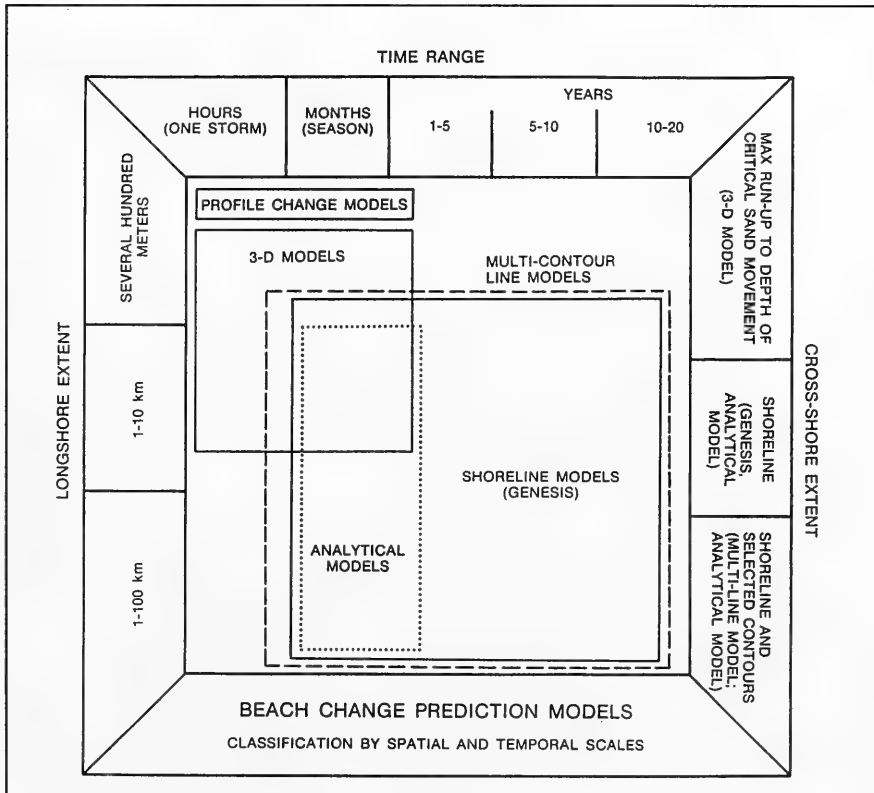

Figure 50. Classification of beach change models (Kraus 1989)

- Analytical models of shoreline change. These are closed-form mathematical solutions of simplified differential equations for shoreline change derived under assumptions of steady wave conditions, idealized initial shoreline and structure positions, and simple boundary conditions. Because of the many simplifications needed to obtain closed-form solutions, these models are too crude to use for design.

- Profile change/beach erosion models. These are used to calculate sand loss on the upper profile caused by storm surge and waves. The models are one-dimensional, assuming that longshore currents are constant. Extra work needs to be done to extend their use to simulate major morphological features such as bars and berms.
- Shoreline change models. These models generalize spatial and temporal changes of shorelines analytically in response to a wide range of beach, wave, coastal structure, initial and boundary conditions. These conditions can vary with time. Because the profile shape is assumed to remain constant, onshore and offshore movement of any contour can be used to represent beach change. These models are sometimes referred to as "one-contour line" or "one-line" models. The representative contour line is usually taken to be the shoreline (which is conveniently measured or available from a variety of sources). The GENESIS model has been extensively used at CERC (Hansen and Kraus 1989).
- Multi-contour line / schematic three-dimensional (3-D) models. These models describe the response of the bottom to waves and currents, which can vary both cross- and alongshore. The fundamental assumption of constant shoreline profile, necessary for the shoreline change models, is relaxed. 3-D beach change models have not yet reached wide application. They have been limited by their complexity and their large requirements for computer resources and user expertise. In addition, they are still limited by the ability to predict sediment transport processes and wave climates.

Calibration and verification. Model calibration is the procedure of reproducing with a model the changes in the shoreline position that were measured over a certain time interval. Verification refers to the application of the model to reproduce beach changes over a time interval different than the one used for the model's calibration. Successful verification means that the model's predictions are independent of the calibration interval. However, if empirical coefficients or boundary conditions change (for example, by the construction of an entrance channel which interrupts sand transport) the verification is no longer valid. Therefore, a modeler must be aware of any changes in the physical conditions at the study site that could affect the validity of his model.

Unfortunately, in practice, data sets are usually insufficient to perform rigorous calibration and verification of a model. Wave gage data are typically missing, and historical shoreline change maps are usually spotty or unsuitable. In situations where data are lacking, coastal experience must be relied upon to provide reasonable input parameters. This underscores that considerable subjectivity is part of the modeling procedure, even if the model itself may be mathematically rigorous.

Sensitivity testing. This refers to the process of examining changes in the output of a model resulting from intentional changes in the input. If large changes are caused by minor changes in the input, the overall results will depend greatly upon the quality of the verification. Unfortunately, for many practical applications, there is some degree of doubt in the verification (Hansen and Kraus 1989). If a model is oversensitive to small changes in input values, the range of predictions will be too broad and will in essence provide no information.

In summary, numerical models are a valuable complement to prototype data collection and physical (scale) models of coastal processes. However, useful numerical models require empirical input during the calibration and may be based on incomplete data sets. Therefore, the reader is urged to be cautious of the output of any model and to be aware of the results of the verification and sensitivity tests.

6 Summary and Conclusions

A wide variety of techniques and technologies are available for data collection, analysis, and interpretation of the geologic and geomorphic history of coasts. One means of acquiring coastal data is through field data collection and observation. This data may be numerical or non-numerical, and may be analyzed further in the laboratory and office depending upon the type of data collected. Laboratory studies are used to analyze geological properties of data collected in the field, such as grain size or mineralogy, or to collect data through physical model experiments, such as in wave tanks. Office studies are part of most investigations, in that they involve the analysis and/or the interpretation of data collected in the field and laboratory, from primary and secondary sources. These include analysis of historic maps and photographs, as well as application of techniques and numerical simulation of field, laboratory, and office data. Typically, the best overall understanding of environmental processes and the geologic history of coasts is acquired through a combination of techniques and lines of inquiry. A suggested flowchart for conducting studies of coastal geology is illustrated in Figure 51.

The techniques and technologies for the study of the geologic and geomorphic history of coasts are applicable over a variety of time scales. Three principal time scales that are important in assessing the geologic and geomorphic changes of coasts include the following: 1) modern studies, which are based largely on field data or laboratory and office experiments of environmental processes; 2) historic studies, which are based largely on information from maps, photography, archives, and other sources; and, 3) paleoenvironmental studies, which are based largely on stratigraphy and associated geological and paleoenvironmental principles. In actuality, however, these general time scale approaches overlap. Further, within each of the categories, certain time scales may be of particular importance for influencing coastal changes.

Before initiating detailed field, laboratory, or office study, it is recommended that a thorough literature review and investigation of secondary data sources be conducted. Existing sources of data are numerous, including information on processes such as waves, water levels, and currents, information on geomorphology such as geologic, topographic, and shoreline change maps, as well as information that has been previously interpreted in the literature or has yet to be interpreted, such as aerial photography and

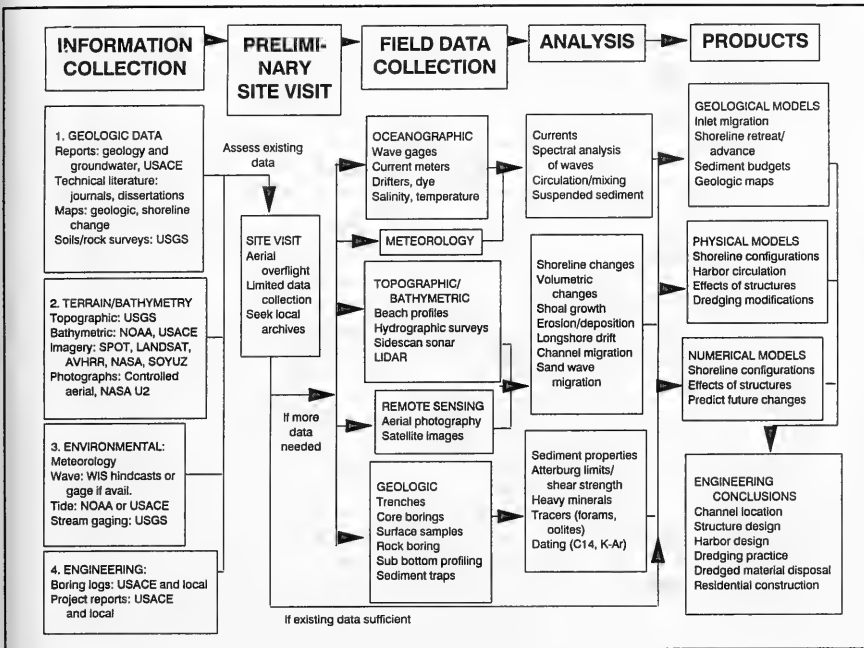

Figure 51. Flowchart for studies of coastal geology

scanner images. If such a search is not conducted, assessment of geologic history is likely to be less reliable and more difficult.

Many recent developments and techniques are used in the analysis of coastal data sets. The evaluation of geologic and geomorphic history is largely dependent upon the availability and quality of research equipment, techniques, and facilities. New techniques are constantly being introduced, and it is important that the coastal geologist and engineer stay abreast of new techniques and methods, such as remote sensing and geophysical methods, computer software and hardware developments, and new laboratory methods.

In addition to keeping up with recent developments, the coastal scientist or engineer has the serious responsibility for making accurate interpretations of the geologic and geomorphic history of coasts. It is vital that the important research problem and objectives be clearly defined, that important variables be incorporated in the study, and that the inherent limits and errors of the research techniques and technologies be recognized, including problems and assumptions involved in data collection and analysis. To some extent, the coastal scientist or engineer can make some adjustments for various sources of error. However, because of the geologic and geomorphic variability of

coasts, extreme caution should be taken in extrapolating the final interpretations and conclusions regarding geologic history, particularly from data covering a short time period or a small area. For these reasons, the assessment of geologic and geomorphic history of coasts is an exceptionally challenging endeavor.

References

- Allen, J. R. L. 1968. *Current Ripples: Their Relation to Patterns of Water and Sediment Movement*. North Holland, Amsterdam, The Netherlands.
- _____. 1985. *Principles of Physical Sedimentology*. George Allen and Unwin, London, UK.
- American Society For Testing and Materials. 1964. *Procedures for Testing Soils*, 4th ed., ASTM Committee D-18, Philadelphia, PA.
- Anders, F. J., and Byrnes, M. R. 1991. "Accuracy of shoreline change rates as determined from maps and aerial photographs." *Shore and Beach*, Vol 9, No. 1, pp 17-26.
- Anders, F. J., Reed, D. W., and Meisburger, E. P. 1990. "Shoreline movements, Report 2: Tybee Island, Georgia to Cape Fear, North Carolina: 1851-1983." Technical Report CERC-83-1, U.S. Army Engineer Waterways Experiment Station, Vicksburg, MS.
- Appell, G. F., and Curtin, T. B., eds. 1990. *Proceedings of the IEEE Fourth Working Conference on Current Measurement*, Current Measurement Technology Committee of the Oceanic Engineering Society, Institute of Electrical and Electronics Engineers, New York.
- Ashley, G. M. 1990. "Classification of large-scale subaqueous bedforms: A new look at an old problem." *Journal of Sedimentary Petrology*, Vol 60, No. 1, pp 160-172.
- Aubrey, D. G., and Weishar, L., eds. 1988. "Hydrodynamics and sediment dynamics of tidal Inlets." Lecture Notes on Coastal and Estuarine Studies 29, Springer-Verlag, New York.

- Barrick, D. E., Lipa, B. J., and Lilleboe, P. M. 1990. "HF radar surface-current mapping: recent U.S./Canadian advances." *Proceedings of the IEEE fourth working conference on current measurement*, G. F. Appell, and T. B. Curtin, eds., Current Measurement Technology Committee of the Oceanic Engineering Society, Institute of Electrical and Electronics Engineers, New York, pp 22-29.
- Barrick, D. E., Evans, M. W., and Weber, B. L. 1977. "Ocean surface currents mapped by radar." *Science*. Vol 198, pp 138-144.
- Bascom, W. 1964. *Waves and Beaches*. Anchor Books, Doubleday & Company, Inc., Garden City, New York.
- Bates, R. L., and Jackson, J. A. 1984. *Dictionary of Geological Terms*. 3rd ed. Anchor Press/Doubleday, Garden City, New York.
- Bendat, J. S., and Piersol, A. G. 1986. *Random Data-Analysis and Measurement Procedures*. 2nd ed. John Wiley & Sons, New York.
- Birkemeier, W. A., Kraus, N. C., Scheffner, N. W., and Knowles, S. C. 1987. "Feasibility study of quantitative erosion models for use by the Federal Emergency Management Agency." Technical Report CERC-87-8, U.S. Army Engineer Waterways Experiment Station, Vicksburg, MS.
- Boggs, S., Jr. 1987. *Principles of Sedimentology and Stratigraphy*. Merrill Publishing Company, Columbus, OH.
- Boothroyd, J. C. 1985. "Tidal inlets and tidal deltas." *Coastal Sedimentary Environments*. R. A. Davis, Jr., ed., 2nd ed., Springer-Verlag, New York, pp 445-532.
- Bos, W. G. 1990. "A comparison of two doppler current profilers." *Proceedings of the IEEE Fourth Working Conference on Current Measurement*. G. F. Appell, and T. B. Curtin, eds. Current Measurement Technology Committee of the Oceanic Engineering Society, Institute of Electrical and Electronics Engineers, New York, pp 207-214.
- Bowen, A. J. 1969. "Rip currents, 1: Theoretical investigations." *Journal of Geophysical Research*, Vol 74, pp. 5467-5478.
- Bowen, A. J., and Inman, D. L. 1969. "Rip currents, 2. Laboratory and field observations." *Journal of Geophysical Research*, Vol 74, pp 5479-5490.
- Bowles, J. E. 1986. *Engineering Property of Soils and Their Measurement*. 3rd ed. McGraw-Hill, New York.

- Brenninkmeyer, B. M. 1978. "Heavy minerals." *The Encyclopedia of Sedimentology*. R.W. Fairbridge and J. Bougeois, eds., Dowden, Hutchinson and Ross, Inc., Stroudsburg, PA, pp 400-402.
- Bretherton, F. P., Davis, R. E., and Fandry, C. B. 1976. "A technique for objective analysis and design of oceanographic experiments applied to MODE-73." *Deep-Sea Research*, Vol 23, pp. 559-582.
- Brinker, R. C., and Wolf, P. R. 1984. *Elementary Surveying*. 7th ed., Harper and Row Publishers, New York.
- Buller, A. T., and McManus, J. 1979. "Sediment Sampling and Analysis." *Estuarine Hydrography and Sedimentation*. K. R. Dyer, ed., Cambridge University Press, Cambridge, UK.
- Carter, R. W. G. 1988. *Coastal Environments: An Introduction to the Physical, Ecological, and Cultural Systems of Coastlines*. Academic Press, London, UK.
- Chave, A. D., Luther, D. S., and Filloux, J. H. 1990. "Spatially-averaged velocity from the seafloor horizontal electrical field." *Proceedings of the IEEE Fourth Working Conference on Current Measurement*. G. F. Appell and T. B. Curtin, eds., Current Measurement Technology Committee of the Oceanic Engineering Society, Institute of Electrical and Electronics Engineers, New York, NY, pp. 46-53.
- Chu, Y., Lund, R. B., and Camfield, F. E. 1987. "Sources of coastal engineering information." Technical Report CERC-87-1, U.S. Army Engineer Waterways Experiment Station, Vicksburg, MS.
- Clausner, J. E., Birkemeier, W. A., and Clark, G. R. 1986. "Field comparison of four nearshore survey systems." Miscellaneous Paper CERC-86-6, U.S. Army Engineer Waterways Experiment Station, Vicksburg, MS.
- Clifton, H. E., and Dingler, J. R. 1984. "Wave-formed structures and paleoenvironmental reconstruction." *Marine Geology*, Vol 60, pp 165-198.
- Coastal Engineering Research Center. 1991. "Recommended physical data collection program for beach renourishment projects." Coastal Engineering Technical Note CETN II-26, U.S. Army Engineer Waterways Experiment Station, Vicksburg, MS.
- Colwell, R. N., editor-in-chief. 1983. *Manual of Remote Sensing*. 2nd ed., in 2 volumes. American Society of Photogrammetry, Falls Church, VA.
- Cook, D. O., and Gorsline, D. S. 1972. "Field observations of sand transport by shoaling waves." *Marine Geology*, Vol 13, pp 31-55.

- Crowell, M., Leatherman, S. P., and Buckley, M. K. 1991. "Historical shoreline change-error analysis and mapping accuracy." *Journal of Coastal Research*, Vol 7, No. 3, pp 839-852.
- Curry, J. R. 1965. "Late quaternary history, continental shelves of the United States." *The Quaternary of the United States*. H. E. Wright, Jr. and D. G. Frey, eds., Princeton University Press, Princeton, NJ, pp 713-735.
- Davidson-Arnott, R. G. D., and Greenwood, B. 1976. "Facies relationships on a barred coast, Kouchibouguac Bay, New Brunswick, Canada." *Beach and Nearshore Sedimentation*. R. A. Davis, Jr., and R. L. Ethington, eds., Society of Economic Paleontologists and Mineralogists Special Publication 24, Tulsa, OK, pp 149-168.
- Davis, R. E., and Weller, R. A. 1980. "Propeller current sensors." *Air-Sea Interaction-Instruments and Methods*. F. Dobson, L. Masse, and R. Davis, eds., Plenum Press, New York, pp. 141-153.
- Davis, R. A., Jr., ed. 1985. *Coastal Sedimentary Environments*. Springer-Verlag, New York.
- Dillon, W. D., and Oldale, R. N. 1978. "Late quaternary sea level curve: reinterpretation based on glacio-eustatic influence." *Geology*. Vol 6, pp 56-60.
- Dolan, R., and Hayden, B. 1983. "Patterns and predictions of shoreline change." *CRC Handbook of Coastal Processes and Erosion*. P. D. Komar, ed., CRC Press, Inc., Boca Raton, FL, pp 123-149.
- Dolan, R., Hayden, B., and May, S. 1983. "Erosion of the U.S. shorelines." *CRC Handbook of Coastal Processes and Erosion*. P. D. Komar, ed., CRC Press, Inc., Boca Raton, FL, pp 285-299.
- Dorn, R. I. 1983. "Cation-ratio dating: A new rock varnish age-determination technique." *Quaternary Research*. Vol 20, pp 49-73.
- Dugdale, R. 1981. "Coastal processes." *Geomorphological Techniques*, pp 247-265.
- Emery, K. O. 1941. "Rate of surface retreat of sea cliffs based on dated inscriptions." *Science*. Vol 93, p 617-8.
- Emery, K. O., and Aubrey, D. G. 1991. *Sea Levels, Land Levels, and Tide Gauges*. Springer-Verlag, New York.
- Escoffier, F. F. 1977. "Hydraulics and stability of tidal inlets." General Investigation of Tidal Inlets Report 13, U.S. Army Engineer Waterways Experiment Station, Vicksburg, MS.

- Faegri, K., and Iverson, J. 1975. *Textbook of Pollen Analysis*. Blackwell, Oxford, UK.
- Faure, G. 1977. *Principles of Isotope Geology*. John Wiley & Sons, New York.
- Folk, R. L. 1980. *Petrology of Sedimentary Rocks*. Hemphill Publishing Company, Austin, TX.
- Fredette, T. J., Nelson, D. A., Miller-Way, T., Adair, J. A., Sotler, V. A., Clausner, J. E., Hands, E. B., and Anders, F. J. 1990. "Selected tools and techniques for physical and biological monitoring of aquatic dredged material disposal sites." Technical Report D-90-11, Dredging Operations Technical Support Program, U.S. Army Engineer Waterways Experiment Station, Vicksburg, MS.
- Friedlander, G., Kennedy, J. W., and Miller, J. M. 1955. *Nuclear and Radiochemistry*. John Wiley & Sons, New York.
- Fulton, K. 1981. "A manual for researching historical coastal erosion." California Sea Grant College Program, Report No. T-CSGCP-003.
- Galvin, C. J. 1968. "Breaker type classification on three laboratory beaches." *Journal of Geophysical Research*. Vol 73, pp 3651-3659.
- Glen, N. C. 1979. "Tidal measurement." *Estuarine Hydrography and Sedimentation*. K. R. Dyer, ed., Cambridge University Press, Cambridge, UK.
- Gordon, R. L., Berezutskii, A. V., Kaneko, A., Stocchino, C., and Weisberg, R. H. 1990. "A review of interesting results obtained with acoustic doppler current profilers." *Proceedings of the IEEE Fourth Working Conference on Current Measurement*. G. F. Appell and T. B. Curtin, eds., Current Measurement Technology Committee of the Oceanic Engineering Society, Institute of Electrical and Electronics Engineers, New York, pp 180-191.
- Gorman, L. T. 1991. "Annotated bibliography of relative sea level change." Technical Report CERC-91-16, U.S. Army Engineer Waterways Experiment Station, Vicksburg, MS.
- Goudie, A., ed. 1981. *Geomorphological Techniques*. George Allen and Unwin, London, UK.
- Graf, W. H. 1984. *Hydraulics of Sediment Transport*. Water Resources Publications, Littleton, CO.
- Great Lakes Commission. 1986. "Water level changes; factors influencing the great lakes." Great Lakes Commission, Ann Arbor, Michigan.

- Halpern, D. 1980. "Moored current measurements in the upper ocean." *Air-Sea Interaction --Instruments and Methods*. F. Dobson, L. Hasse, and R. Davis, eds., Plenum Press, New York, pp 127-140.
- Halpern, D. 1978. "Mooring motion influences on current measurements." *Proceedings of a Working Conference on Current Measurement*, Technical Report DEL-SG-3-78, College of Marine Studies, University of Delaware, Newark, DE, pp 69-76.
- Hands, E. B. 1979. "Changes in rates of shore retreat, Lake Michigan, 1967-76." Technical Paper No. 79-4, U.S. Army Corps of Engineers Coastal Engineering Research Center, Fort Belvoir, VA.
- _____. 1980. "Prediction of shore retreat and nearshore profile adjustments to rising water levels on the Great Lakes." Technical Paper No. 8-0-7, U.S. Army Corps of Engineers Coastal Engineering Research Center, Fort Belvoir, VA.
- Hansen, H., and Kraus, N.C. 1989. "GENESIS: generalized model for simulating shoreline change." Technical Report CERC-89-19, U.S. Army Engineer Waterways Experiment Station, Vicksburg, MS.
- Harms, J. C. 1969. "Hydraulic significance of some sand ripples." *Bulletin of the Geological Society of America*. Vol 80, pp 363-396.
- Hayes, M. O. 1980. "General morphology and sediment patterns in tidal inlets." *Sedimentary Geology*. Vol 26, pp 139-156.
- Hayes, M. O., and Kana, T. W. 1976. "Terrigenous clastic depositional environments: some modern examples." AAPG Field Course Guidebook and Lecture Notes, Technical Report No. 11-CRD, Coastal Research Division, Department of Geology, University of South Carolina.
- Headquarters, U.S. Army Corps of Engineers. 1959. "Flood hydrograph analyses and computations." Engineer Manual 1110-2-1405, Washington, DC.
- _____. 1970. "Laboratory soils testing." Engineer Manual 1110-2-1906, Washington, DC.
- _____. 1972. "Soil sampling." Engineer Manual 1110-2-1907, Washington, DC.
- _____. 1987. "Hydrologic analysis of interior areas." Engineer Manual 1110-2-1413, Washington, DC.
- _____. 1989. "Water levels and wave heights for coastal engineering design." Engineer Manual 1110-2-1414, Washington, DC.

- Headquarters, U.S. Army Corps of Engineers. 1991. "Hydrographic surveying." Engineer Manual 1110-2-1003, Washington, DC.
- Hemsley, J. M. 1981. "Guidelines for establishing coastal survey base lines." Coastal Engineering Technical Aid No. 81-15, U.S. Army Corps of Engineers Coastal Engineering Research Center, Fort Belvoir, VA.
- Hicks, S. D. 1972. "Changes in tidal characteristics and tidal datum planes." *The Great Alaska Earthquake of 1964*. Oceanography and Coastal Engineering, National Academy of Sciences, Washington, DC, pp 310-314.
- Hicks, S. D., Debaugh, H. A., Jr., and Hickman, L. E., Jr. 1983. "Sea-level variations for the United States 1855-1980." National Oceanic and Atmospheric Administration, Rockville, MD.
- Hobson, R. D. 1979. "Definition and use of the phi grade scale." Coastal Engineering Technical Aid No. 79-7, U.S. Army Corps of Engineers Coastal Engineering Research Center, Fort Belvoir, VA.
- Horikawa, K., ed. 1988. *Nearshore Dynamics and Coastal Processes: Theory, Measurement and Predictive Models*, University of Tokyo Press, Tokyo, Japan.
- Howell, G. L., and Rhee, J. P. 1990. "Investigation of seismic wave techniques and comparative evaluation of the seismic wave gage at Chetco River, Oregon." Miscellaneous Paper CERC-90-3, U.S. Army Engineer Waterways Experiment Station, Vicksburg, MS.
- Hughes, S. A. 1988. "Laboratory measurement of spatial and temporal suspended sediment concentration under waves." Miscellaneous Paper CERC-88-1, U.S. Army Engineer Waterways Experiment Station, Vicksburg, MS.
- Huh, O. K., and Leibowitz, S. G. 1986. "User's guide to image processing. Applications of the NOAA satellite HRPT/AVHRR data." Technical Report 301.86, Remote Sensing and Image Processing Laboratory, Louisiana State University, Baton Rouge, LA.
- Hunt, R. E. 1984. *Geotechnical Engineering Investigation Manual*. McGraw-Hill, New York.
- IAHR Working Group on Wave Generation and Analysis 1989. "List of sea-state parameters," *Journal of the Waterway, Port, and Ocean Engineering*, American Society of Civil Engineers, Vol 115, No. 6, pp 793-809.
- Ingle, J. C. 1966. *The Movement of Beach Sand*, Elsevier, NY.

- Inman, D. L. 1953. "Areal and seasonal variations in beach and nearshore sediments at La Jolla, California." U.S. Army Beach Erosion Board, Technical Memo 39, Fort Belvoir, VA.
- Jopling, A. V. 1966. "Some principles and techniques used in reconstructing the hydraulic parameters of a paleo-flow regime." *Journal of Sedimentary Petrology*. Vol 36, pp 5-49.
- Judge, C. W. 1970. "Heavy minerals in beach and stream sediments as indicators of shore processes between Monterey and Los Angeles, California." Technical Memorandum No. 33, U.S. Army Corps of Engineers Coastal Engineering Research Center, Washington, DC.
- Kapp, R. O. 1969. *How to Know Pollen and Spores*. Brown, Dubuque, IA.
- Komar, P. D. 1976. *Beach Processes and Sedimentation*. Prentice-Hall, Inc., Englewood Cliffs, NJ.
- _____. 1983. "Computer models of shoreline changes." *CRC Handbook of Coastal Processes and Erosion*. P. D. Komar, ed., CRC Press, Inc., Boca Raton, FL, pp 205-216.
- _____. 1992. "Ocean processes and hazards along the Oregon coast." *Oregon Geology*. Vol 54, No. 1, pp 3-19.
- Kraus, N. C. 1987. "Application of portable traps for obtaining point measurements of sediment transport rates in the surf zone." *Journal of Coastal Research*. Vol 3, No. 2, pp 139-152.
- _____. 1989. "Beach change modeling and the coastal planning process." *Coastal Zone '89: Proceedings of the Sixth Symposium on Coastal and Ocean Management*. American Society of Civil Engineers, Charleston, SC, pp 553-567.
- Kraus, N. C., and Dean, J. L. 1987. "Longshore sand transport rate distributions measured by trap." *Coastal Sediments '87*. American Society of Civil Engineers, New Orleans, LA, pp 881-896.
- Kraus, N. C., and Gorman, L. T., eds. "Kings Bay Coastal and Estuarine Physical Monitoring and Evaluation Program: Coastal Studies, Vol I: Main Text and Appendix A," in preparation, U.S. Army Engineer Waterways Experiment Station, Vicksburg, MS.
- Kraus, N. C., ed. 1990. "Shoreline change and storm-induced beach erosion modeling: a collection of seven papers." Miscellaneous Paper CERC-90-2, U.S. Army Engineer Waterways Experiment Station, Vicksburg, MS.
- Leeder, M. R. 1982. *Sedimentology: Process and Product*. George Allen and Unwin, London, UK.

- Lewis, D. W. 1984. *Practical Sedimentology*. Hutchinson Ross, Stroudsburg, PA.
- Lillesand, T. M., and Kiefer, R. W. 1987. *Remote Sensing and Image Interpretation*. 2nd ed., John Wiley and Sons, New York.
- Linsley, R. K., Jr., and Kohler, M. A. 1982. *Hydrology for Engineers*. 3rd ed., McGraw Hill Book Company, New York.
- Lisitzin, E. 1974. *Sea-Level Changes*. Elsevier Oceanography Series, 8, Elsevier Scientific Publishing Company, Amsterdam, The Netherlands.
- Longuet-Higgins, M. S., Cartwright, D. E., and Smith, N. D. 1963. "Observations of the directional spectrum of sea waves using the motions of a floating buoy." *Ocean Wave Spectra*. Prentice-Hall, Englewood Cliffs, NJ, pp 111-136.
- Lyles, S. D., Hickman, L. E., Jr., and Debaugh, H. A., Jr. 1988. "Sea level variations for the United States 1855-1986." U.S. Department of Commerce, National Oceanic and Atmospheric Administration, National Ocean Service, Rockville, MD.
- Mason, C. C., and Folk, R. L. 1958. "Differentiation of beach, dune, and aeolian flat environments by size analysis, Mustang Island, Texas." *Journal of Sedimentary Petrology*. Vol 28, pp 211-226.
- May, J. R., and Britsch, L. D. 1987. "Geological investigation of the Mississippi River delta plain: Land loss and land accretion." Technical Report GL-87-13, U.S. Army Engineer Waterways Experiment Station, Vicksburg, MS.
- McCullough, J. R. 1980. "Survey of techniques for measuring currents near the ocean surface." *Air-Sea Interaction-Instruments and Methods*. F. Dobson, L. Hasse, and R. Davis, ed., Plenum Press, New York, pp 105-126.
- McIntire, W. G. 1958. "Correlation of prehistoric settlements and delta development." Louisiana State University Coastal Studies Series No. 1, University Press, Baton Rouge, LA.
- McMaster, R. L. 1960. "Mineralogy as an indicator of beach and sand movement along the Rhode Island shore." *Journal of Sedimentary Petrology*. Vol 30, No. 3, pp 404-413.
- Meisburger, E. P. 1992. "Techniques of sediment budget analysis using geologic data," in preparation, U.S. Army Engineer Waterways Experiment Station, Vicksburg, MS.

- Middleton, G. V., compiler. 1977. *Sedimentary Processes: Hydraulic Interpretation of Primary Sedimentary Structures*. Reprint Series Number 3, Society of Economic Paleontologists and Mineralogists, Tulsa, OK.
- Middleton, G. V., and Southard, J. B. 1984. "Mechanics of sediment transport." Short Course No. 3, Society for Sedimentary Geology (SEPM), Tulsa, OK.
- Milliman, J. D., and Emery, K. O. 1968. "Sea levels during the past 35,000 years." *Science*. Vol 162, pp 1121-1123.
- Morang, A. 1990. "Quality control and management of oceanographic wave gage data." Instruction Report CERC-90-1, U.S. Army Engineer Waterways Experiment Station, Vicksburg, MS.
- _____. 1992. "A study of geologic and hydraulic processes at East Pass, Destin, Florida." (in 2 volumes), Technical Report CERC-92-5, U.S. Army Engineer Waterways Experiment Station, Vicksburg, MS.
- Morang, A., and McMaster, R. L. 1980. "Nearshore bedform patterns along Rhode Island from side-scan sonar surveys." *Journal of Sedimentary Petrology*. Vol 50, No. 3, pp 831-840.
- Mossa, J., Meisburger, E. P., and Morang, A. 1992. "Geomorphic variability in the coastal zone." Technical Report CERC-92-4, U.S. Army Engineer Waterways Experiment Station, Vicksburg, MS.
- National Oceanic and Atmospheric Administration. 1976. *Hydrographic Manual*. 4th ed., U.S. Department of Commerce, Rockville, MD.
- Neiheisel, J. 1962. "Heavy-mineral investigation of recent and Pleistocene sands of lower coastal plain of Georgia." *Geological Society of America Bulletin*. Vol 73, pp 365-374.
- Nicholls, R. J., and Webber, N. B. 1987. "Aluminum pebble tracer studies on Hurst Castle Spit." *Coastal Sediments 87*. American Society of Civil Engineers, New Orleans, LA, pp 1563-1577.
- Nichols, M. M., and Biggs, R. B. 1985. "Estuaries." *Coastal Sedimentary Environments*. R. A. Davis, Jr., ed., 2nd ed., Springer-Verlag, New York, pp 77-186.
- Nordstrom, C. E., and Inman, D. L. 1975. "Sand level changes on Torrey Pines Beach, California." U.S. Army Coastal Engineering Research Center, Fort Belvoir, VA.
- Oldfield, F. 1981. "Peats and lake sediments: Formation, stratigraphy, description, and nomenclature." *Geomorphological Techniques*, A. Goudie, ed., George Allen and Unwin, London, U.K., pp 306-326.

- Oldfield, F., and Appleby, P. G. 1984. "Empirical testing of ^{210}Pb -dating models for lake sediments." *Lake Sediments and Environmental History*. E. Y. Haworth and J. W. G. Lund, eds., Leicester University Press, Leicester, U.K., pp 3-124.
- Payton, C. E., ed. 1977. *Seismic stratigraphy-applications to hydrocarbon exploration*. Memoir 26, American Association of Petroleum Geologists, Tulsa, OK.
- Peterson, C., Scheidegger, K., Komar, P. D., and Niem, W. 1984. "Sediment composition and hydrography in six high-gradient estuaries of the northwestern United States." *Journal of Sedimentary Petrology*. Vol 54, No. 1, pp 86-97.
- Pethick, J. 1984. *An Introduction to Coastal Geomorphology*. Edward Arnold, Inc., New York.
- Pierce, K.L., Obradovich, J. D., and Friedman, I. 1976. "Obsidian hydration dating and correlation of Bull Lake and Pinedale glaciations near West Yellowstone, Montana." *Geological Society of America Bulletin*. Vol 87, pp 703-710.
- Pinkel, R. 1980. "Acoustic Doppler techniques." *Air-Sea Interaction-Instruments and Methods*. F. Dobson, L. Hasse, and R. Davis, eds., Plenum Press, New York, pp. 171-199.
- Reineck, H.-E., and Singh, I. B. 1980. *Depositional Sedimentary Environments: With Reference to Terrigenous Clastics*. 2nd ed., Springer-Verlag, Berlin, Germany.
- Richards, V. A. 1986. *Remote Sensing Digital Image Analysis, An Introduction*. Springer Verlag, Berlin, Germany.
- Roberts, H. H. 1981. "X-ray radiography." *Geomorphological Techniques*. A. Goudie, ed., George Allen and Unwin, London, U.K., pp 101-102.
- Sarna-Wojcicki, A. M., Champion, D. E., and Davis, J. O. 1983. "Holocene volcanism in the coterminous United States and the role of silicic volcanic ash layers in correlation of the latest Pleistocene and Holocene deposits." *Late Quaternary Environments of the United States: The Holocene*, H. E. Wright, ed., Vol 2, University of Minnesota Press, Minneapolis, pp 52-77.
- Sabins, F. F., Jr. 1987. *Remote Sensing, Principles and Interpretation*. 2nd ed, W. H. Freeman and Company, New York.
- Sahagian, D. L., and Holland, S. M. 1991. "Eustatic sea-level curve based on a stable frame of reference preliminary results." *Geology*. Vol 19, pp 1209-1212.

- Savage, R. J., and Birkemeier, W. A. 1987. "Storm erosion data from the United States Atlantic coast." *Coastal Sediments 87*. ASCE, New Orleans, LA, pp 1445-1459.
- Saville, T., Jr., and Caldwell, J. M. 1953. "Accuracy of hydrographic surveying in and near the surf zone." Technical Memorandum No. 32, Beach Erosion Board, Corps of Engineers, Department of the Army, Washington, D.C.
- Schneider, C. 1981. "The Littoral Environment Observation (LEO) Data Collection Program." Coastal Engineering Research Center Technical Aid 81-5, Fort Belvoir, VA.
- Schwartz, M. L., ed. 1982. *Encyclopedia of Beaches and Coastal Environments*. Hutchinson Ross Publishing Co., Stroudsburg, PA.
- Seabergh, W. C., and McCoy, J. W. 1982. "Prevention of shoaling at Little Lake Harbor, Michigan." Technical Report HL-82-16, U.S. Army Engineer Waterways Experiment Station, Vicksburg, MS.
- Seelig, W. N., Harris, D. L., and Herchenroder, B. E. 1977. "A spatially integrated numerical model of inlet hydraulics." General Investigation of Tidal Inlets Report 14, U.S. Army Engineer Waterways Experiment Station, Vicksburg, MS.
- Seymour, R. J., ed. 1989. *Nearshore Sediment Transport*. Plenum Press, New York.
- Sheriff, R. E. 1980. *Seismic Stratigraphy*, International Human Resources Development Corporation, Boston, MA.
- Sherlock, A. R., and Szuwalski, A. 1987. "A users guide to the Littoral Environment Observation Retrieval System." Instruction Report CERC-87-3, U.S. Army Engineer Waterways Experiment Station, Vicksburg, MS, 27 pp.
- Shore Protection Manual*. 1984. 4th ed, 2 vols, U.S. Army Engineer Waterways Experiment Station, Coastal Engineering Research Center, US Government Printing Office, Washington, D.C.
- Siegal, B. S., and Gillespie, A. R., eds. 1980. *Remote Sensing in Geology*. John Wiley & Sons, New York.
- Spain, P. 1990. "Observing depth-averaged and superficial currents across the North Pacific." *Proceedings of the IEEE Fourth Working Conference on Current Measurement*, G. F. Appell and T. B. Curtin, eds., Current Measurement Technology Committee of the Oceanic Engineering Society, Institute of Electrical and Electronics Engineers, New York, pp 54-64.

- Sternberg, R. W. 1989. "Instrumentation for estuarine research." *Journal of Geophysical Research*. Vol 94, No. C10, pp 14,289-14,301.
- Stewart, R. H. 1985. *Methods of Satellite Oceanography*. University of California Press, Berkeley, CA.
- Sunamura, T. 1983. "Processes of sea cliff and platform erosion." *CRC Handbook of Coastal Processes and Erosion*. P. D. Komar, ed., CRC Press, Boca Raton, FL, pp 233-266.
- Tang, E. C.-S., and Dalrymple, R. A. 1989. "Nearshore circulation B. rip currents and wave groups." *Nearshore Sediment Transport*. R. J. Seymour, ed., Plenum Press, New York, pp 205-230.
- Tanner, W. F. 1967. "Ripple mark indices and their uses." *Sedimentology*. Vol 9, pp 89-104.
- Teleki, P. G., Musialowski, F. R., and Prins, D. A. 1976. "Measurement techniques for coastal waves and currents." Information Report 76-11, Coastal Engineering Research Center, Fort Belvoir, VA.
- Teleki, P. G. 1966. "Fluorescent sand tracers." *Journal of Sedimentary Petrology*. Vol 36, pp 376-468.
- Thompson, E. F., Howell, G. L., and Smith, J. M. 1985. "Evaluation of seismometer wave gage and comparative analysis of wave data at Yaquina and Coquille Bays, Oregon," Miscellaneous Paper CERC-85-12, U.S. Army Engineer Waterways Experiment Station, Vicksburg, MS.
- Trimble, S. W., and Cooke, R. U. 1991. "Historical sources for geomorphology research in the United States." *The Professional Geographer*. Vol 43, pp 212-27.
- Trump, C. L. 1990. "Single Ping ADCP Data." *Proceedings of the IEEE Fourth Working Conference on Current Measurement*. G. F. Appell and T. B. Curtin, eds., Current Measurement Technology Committee of the Oceanic Engineering Society, Institute of Electrical and Electronics Engineers, New York, pp 215-224.
- Vachon, W. A. 1980. "Drifters." *Air-Sea Interaction-Instruments and Methods*. F. Dobson, L. Hasse, and R. Davis, eds., Plenum Press, New York, pp 201-218.
- Vanoni, V. A., ed. 1975. "Sedimentation Engineering," Manuals and Reports on Engineering Practice No. 54, American Society of Civil Engineers, New York.

- Walton, T. L., Jr. 1990. "Simulating Great Lakes water levels for erosion prediction." Miscellaneous Paper CERC-90-6, U.S. Army Engineer Waterways Experiment Station, Vicksburg, MS.
- Weaver, H. J. 1983. *Applications of Discrete and Continuous Fourier Analysis*. John Wiley & Sons, New York.
- Wells, J. T., and Coleman, J. M. 1981. "Periodic mudflat progradation, northeastern coast of South America: a hypothesis." *Journal of Sedimentary Petrology*. Vol 51, No. 4, pp 1069-1075.
- Wise, S. M. 1980. "Caesium-137 and Lead-210: A review of the techniques and some applications in geomorphology." *Timescales in Geomorphology*. R. A. Cullingford, D. A. Davidson, and J. Lewin, eds., John Wiley, Chichester, U.K., pp 107-127.
- Worsley, P. 1981. "Lichenometry." *Geomorphological Techniques*. A. Goudie, ed., George Allen and Unwin, London, UK, pp 302-305.
- Wright, L. D., Sonu, C. J., and Kielhorn, W. V. 1972. "Water-mass stratification and bed form characteristics in East Pass, Destin, Florida." *Marine Geology*, Vol 12, pp 43-58.
- Wright, L. D. 1985. River Deltas, *Coastal Sedimentary Environments*, 2nd ed, R. A. Davis, Jr., ed., Springer-Verlag, New York, NY, pp 1-76.
- Wunsch, C. 1978. "The North Atlantic general circulation west of 50 deg W determined by inverse methods." *Reviews of Geophysics and Space Physics*. Vol 16, No. 4, pp 583-620.
- Wunsch, C., and Minister, J. F. 1982. "Methods for box models and ocean circulation tracers: Mathematical programming and nonlinear inverse theory." *Journal of Geophysical Research*. Vol 87, pp 5647-5662.

Appendix A

Glossary

ANOXIC Refers to ocean basins which contain little or no dissolved oxygen and hence little or no benthic marine life. These conditions arise in basins or fjords where physical circulation of seawater is limited.

BACK BARRIER Pertaining to the lagoon-marsh-tidal creek complex in the lee of a coastal barrier island, barrier spit, or bay mouth barrier (Figure 2).

BARRIERS, COASTAL Elongate, shore parallel, usually sandy features that front coasts in many places and are separated from the mainland by bodies of water of various sizes, and/or salt marshes, lagoons, mud or sand flats, and tidal creeks (Figures 2 and 3).

BED FORMS Deviations from a flat bed generated by stream flow on the bed of an alluvial channel.

BIOTURBATION The disturbance of sediment bedding by the activities of burrowing organisms.

BOTTOMSET (bed) One of the horizontal or gently inclined sediment layers deposited in front of the advancing forest beds of a delta.

CLOSURE DEPTH The depth beyond which sediments are not normally affected by waves.

COASTAL PLAIN A relatively low plain of subdued topography underlain by horizontal or gently sloping sedimentary strata extending inland of a coastline.

CONTINENTAL SHELF The submerged zone bordering a coast from the toe of the shoreface to the depth where there is a marked steepening of slope.

DELTAIC Pertaining to river deltas.

- DOWNDRIFT** The direction in which littoral drift is moving.
- DENDROCHRONOLOGY** The examination and correlation of growth rings of trees with the purpose of dating events in the recent past.
- EL NIÑO** Warm equatorial water which flows southward along the coast of Peru during February and March of certain years. It is caused by poleward motions of air, which cause coastal downwelling, leading to the reversal in the normal north-flowing cold coastal currents. El Niño can cause great reduction in the fisheries and severe economic hardships.
- ESTUARY** A widened tidal mouth at a river valley where fresh water comes into contact with sea water, resulting in mixing and a complex biological and chemical environment.
- EUSTATIC SEA LEVEL CHANGE** Change in the relative volume of the world's ocean basins and the total amount of ocean water. It must be measured by recording the movement in sea surface elevation relative to a stable, undeformed, universally adopted reference frame.
- FLUVIAL** Pertaining to streams; e.g. fluvial sediments.
- FORESET (bed)** Inclined layers of a cross-bedded unit, specifically on the frontal slope of a delta or the lee of a dune.
- HALF-LIFE** The time required for half of the atoms of a radioactive element to disintegrate into atoms of another element.
- HEAVY MINERAL** Mineral species with a specific gravity greater than a heavy liquid such as bromoform used to separate heavies from lighter minerals. Usually with a specific gravity of around 2.9 or higher.
- HOLOCENE** An epoch of the Quaternary period from the end of the Pleistocene (approximately 8,000 years ago) to the present. Often used as a synonym for recent.
- INLET** A connecting passage between two bodies of water (Figure 2).
- INTERTIDAL** Between high and low water.
- JETTY** A shore-perpendicular structure built to stabilize an inlet and prevent the inlet channel from filling with sediment.
- LAGOON** Open water between a coastal barrier and the mainland. Also water bodies behind coral reefs and enclosed by atolls (Figure 2).
- LAMINAE (or lamina)** The thinnest recognizable layers in a sediment or sedimentary rock.

- LICHENOMETRY** The study of lichens, complex thallophytic plants consisting of algae and fungus growing in symbiotic association, to determine relative ages of sedimentary structures.
- LITHOLOGY** The general character of a rock or sediment.
- LITTORAL DRIFT** The movement of sediment alongshore. Also the material being moved alongshore.
- MARSH** A permanently or periodically submerged low-lying area that is vegetated.
- MUD FLAT** A level area of fine silt along a shore alternately covered or uncovered by the tide or covered by shallow water.
- NATURAL TRACER** A component of a sediment deposit that is unique to a particular source and can be used to identify the source and transport routes to a place of deposition.
- OVERWASH** A process in which waves penetrate inland of the beach. Particularly common on low barriers.
- PALEOECOLOGY** The study of the relationship between ancient organisms and their environment.
- PALEOSOLS** A buried (possibly ancient) soil.
- PALYNOLOGY** The study of pollen and spores in ancient sediments.
- PEAT** Unconsolidated deposit of semicarbonized plant remains in a water-saturated environment such as a bog. Peat is considered to be an early stage in the development of coal.
- PEDOGENESIS** Soil formation.
- PITCH** Angle between the horizontal and any linear feature.
- PLEISTOCENE** An epoch of the Quaternary period before the Holocene. It began 2 to 3 million years ago and lasted until the start of the Holocene epoch about 8,000 years ago.
- REEF** Ridgelike or moundlike structure built by sedentary calcareous organisms, especially corals.
- RELATIVE SEA LEVEL** Elevation of the sea surface relative to a nearby land surface.

SEDIMENT Solid fragmented material (sand, gravel, silt, etc.) transported by wind, water, or ice or chemically precipitated from solution or secreted by organisms.

SEISMOGRAPH An instrument that records elastic waves in the ground produced by earthquakes, explosions, landslides, or ocean waves.

SELECTIVE SORTING A process occurring during sediment transport that tends to separate particles according to their size, density, and shape.

SHOREFACE A seaward-sloping ramp, seaward of the low water line that leads to the inner continental shelf and is characteristically steeper than the shelf floor (Figure A-1).

SHORELINE The line of demarcation between a shore and the water. May fluctuate periodically due to tide or winds.

SOIL Unconsolidated sediments which contain nutrients, organic matter, etc., and serve as a medium for the growth of land plants.

SPIT An elongated, usually sandy, feature aligned parallel to the coast that terminates in open water (Figure 2).

STRAND PLAIN A prograded shore built seawards by waves and currents (Figure 3).

SUBTIDAL Below the low water datum; thus, permanently submerged.

TEPHRA Clastic materials ejected from a volcano and transported through the air.

TEPHROCHRONOLOGY The collection, description, and dating of tephra.

THERMOLUMINESCENCE The property displayed by many minerals of emitting light when heated.

TIDAL CREEK A creek draining back-barrier areas with a current generated by the rise and fall of the tide.

TIDAL SHOALS Shoals that accumulate near inlets due to the transport of sediments by tidal currents associated with the inlet (Figure 2).

TILT Sideways inclination of an aircraft or spaceship.

UPDRIFT The direction along a coast from which littoral drift material is moving.

VARVE A sedimentary lamina or set of laminae deposited in a body of still water in a year's time.

WASHOVER Sediment deposited inland of a beach by overwash processes (Figure 2).

WEATHERING Destructive process by which atmospheric or biologic agents change rocks, causing physical disintegration and chemical decomposition.

YAW Refers to an aircraft's or spaceship's turning by angular motion about a vertical axis.

Appendix B

List of Wave Information Studies (WIS) Reports

Atlantic, Pacific, and Gulf of Mexico Reports

Corson, W.D., Resio, D. T., and Vincent, C. L. 1980 (July). "Wave Information Study of U.S. Coastlines; Surface Pressure Field Reconstruction for Wave Hindcasting Purposes," TR HL-80-11, WIS Report 1.

Corson, W. D., Resio, D. T., Brooks, R. M., Ebersole, B. A., Jensen, R. E., Ragsdale, D. S., and Tracy, B. A. 1981 (January). "Atlantic Coast Hindcast, Deepwater Significant Wave Information," WIS Report 2.

Corson, W. D., and Resio, D. T. 1981 (May). "Comparisons of Hindcast and Measured Deepwater Significant Wave Heights," WIS Report 3.

Resio, D. T., Vincent, C. L., and Corson, W. D. 1982 (May). "Objective Specification of Atlantic Ocean Windfields from Historical Data," WIS Report 4.

Resio, D. T. 1982 (March). "The Estimation of Wind-Wave Generation in a Discrete Spectral Model," WIS Report 5.

Corson, W. D., Resio, D. T., Brooks, R. M., Ebersole, B. A., Jensen, R. E., Ragsdale, D. S., and Tracy, B. A. 1982 (March). "Atlantic Coast Hindcast Phase II, Significant Wave Information," WIS Report 6.

Ebersole, B. A. 1982 (April). "Atlantic Coast Water-Level Climate," WIS Report 7.

Jensen, R. E. 1983 (September). "Methodology for the Calculation of a Shallow Water Wave Climate," WIS Report 8.

Jensen, R. E. 1983 (January). "Atlantic Coast Hindcast, Shallow-Water Significant Wave Information," WIS Report 9.

- Ragsdale, D. S. 1983 (August). "Sea-State Engineering Analysis System: Users Manual," WIS Report 10.
- Tracy, B. A. 1982 (May). "Theory and Calculation of the Nonlinear Energy Transfer Between Sea Waves in Deep Water," WIS Report 11.
- Resio, D. T., and Tracy, B. A. 1983 (January). "A Numerical Model for Wind-Wave Prediction in Deep Water," WIS Report 12.
- Brooks, R. M., and Corson, W. D. 1984 (September). "Summary of Archived Atlantic Coast Wave Information Study, Pressure, Wind, Wave, and Water Level Data," WIS Report 13.
- Corson, W. D., Abel, C. E., Brooks, R. M., Farrar, P. D., Groves, B. J., Jensen, R. E., Payne, J. B., Ragsdale, D. S., and Tracy, B. A. 1986 (March). "Pacific Coast Hindcast, Deepwater Wave Information," WIS Report 14.
- Corson, W. D., and Tracy, B. A. 1985 (May). "Atlantic Coast Hindcast, Phase II Wave Information: Additional Extremal Estimates," WIS Report 15.
- Corson, W. D., Abel, C. E., Brooks, R. M., Farrar, P. D., Groves, B. J., Payne, J. B., McAneny, D. S., and Tracy, B. A. 1987 (May). "Pacific Coast Hindcast Phase II Wave Information," WIS Report 16.
- Jensen, R. E., Hubertz, J. M., and Payne, J. B. 1989 (March). "Pacific Coast Hindcast, Phase III North Wave Information," WIS Report 17.
- Hubertz, J. M., and Brooks, R. M. 1989 (March). "Gulf of Mexico Hindcast Wave Information," WIS Report 18.
- Able, C. E., Tracy, B. A., Vincent, C. L., and Jensen, R. E. 1989 (April). "Hurricane Hindcast Methodology and Wave Statistics for Atlantic and Gulf Hurricanes from 1956-1975," WIS Report 19.
- Jensen, R. E., Hubertz, J. M., Thompson, E. F., Reinhard, R. D., Groves, B., Brown, W. A., Payne, J. B., Brooks, R. M., and McAneny, D. S. "Southern California Hindcast Wave Information," in preparation, WIS Report 20.
- Tracy, B. A., and Hubertz, J. M. 1990 (November). "Hindcast Hurricane Swell for the Coast of Southern California," WIS Report 21.
- Hubertz, J. M., and Brooks, R. M. "Verification of the Gulf of Mexico Hindcast Wave Information," in preparation, WIS Report 28.

Great Lakes Reports

Resio, D. T., and Vincent, C. L. 1976 (January). "Design Wave Information for the Great Lakes; Report 1: Lake Erie," TR H-76-1.

Resio, D. T., and Vincent, C. L. 1976 (March). "Design Wave Information for the Great Lakes; Report 2: Lake Ontario," TR H-76-1.

Resio, D. T., and Vincent, C. L. 1976 (June). "Estimation of Winds Over the Great Lakes," MP H-76-12.

Resio, D. T., and Vincent, C. L. 1976 (November). "Design Wave Information for the Great Lakes; Report 3: Lake Michigan," TR H-76-1.

Resio, D. T., and Vincent, C. L. 1977 (March). "Seasonal Variations in Great Lakes Design Wave Heights: Lake Erie," MP H-76-21.

Resio, D. T., and Vincent, C. L. 1977 (August). "A Numerical Hindcast Model for Wave Spectra on Water Bodies with Irregular Shoreline Geometry: Report 1, Test of Nondimensional Growth Rates," MP H-77-9.

Resio, D. T., and Vincent, C. L. 1977 (September). "Design Wave Information for the Great Lakes; Report 4: Lake Huron," TR H-76-1.

Resio, D. T., and Vincent, C. L. 1978 (June). "Design Wave Information for the Great Lakes; Report 5: Lake Superior," TR H-76-1.

Resio, D. T., and Vincent, C. L. 1978 (December). "A Numerical Hindcast Model for Wave Spectra on Water Bodies with Irregular Shoreline Geometry," Report 2, MP H-77-9.

Driver, D. B., Reinhard, R. D., and Hubertz, J. M. 1991 (October). "Hindcast Wave Information for the Great Lakes: Lake Erie," WIS Report 22.

Hubertz, J. M., Driver, D. B., and Reinhard, R. D. 1991 (October). "Hindcast Wave Information for the Great Lakes: Lake Michigan," WIS Report 24.

Reinhard, R. D., Driver, D. B., and Hubertz, J. M. 1991 (December). "Hindcast Wave Information for the Great Lakes: Lake Ontario," WIS Report 25.

Reinhard, R. D., Driver, D. B., and Hubertz, J. M. 1991 (December). "Hindcast Wave Information for the Great Lakes: Lake Huron," WIS Report 26.

Driver, D. B., Reinhard, R. D., and Hubertz, J. M. 1992 (January). "Hindcast Wave Information for the Great Lakes: Lake Superior," WIS Report 23.

General User's Information

Hubertz, J. M. 1992 (June). "User's Guide to the Wave Information Studies (WIS) Wave Model, Version 2.0," WIS Report 27.

NOTE:

All reports listed above were published by and are available from the U.S. Army Engineer Waterways Experiment Station, Coastal Engineering Research Center, 3909 Halls Ferry Road, Vicksburg, MS 39180-6199.

Appendix C

List of Selected Sources for Aerial Photography and Other Remote Sensing Data

Agricultural Stabilization and Conservation Service (ASCS)
Aerial Photography Field Office
2222 West 2300 South
P.O. Box 30010
Salt Lake City, UT 84130
(801)524-5856

Soil Conservation Service (SCS)
Cartographic Division
P.O. Box 269
101 Catalpa Drive
Lapalta, MD 20646
(301)870-3555

Bonneville Power Administration (BPA)
Photogrammetry Unit
905 NE 11th Ave
Rt. EFBK
Portland, OR 97208
(503)230-4643

Bureau of Land Management (BLM)
Service Center
Denver Federal Center, Building 50
P.O. Box 25047
Denver, CO 80225-0047
(303)236-6452

Defense Intelligence Agency (DIA)
Clarenton Square Building
3033 Wilson Blvd
Arlington, VA 22201
(703)284-1124

Susquehanna River Basin Commission (SRBC)
1721 N. Front Street
Harrisburg, PA 17102
(717)638-0422

National Ocean Survey (NOS)
Coastal Mapping Division, C-3415
Rockville, MD 20852
(301)713-0610

U.S. Forest Service (USFS)
Division of Engineering
Washington, DC 20250
(202)205-1400

USFS Regional Offices:

Regional Forester
U.S. Forest Service
Federal Building
P.O. Box 7669
Missoula, MT 59807
(406)326-3511

Regional Forester
U.S. Forest Service
11177 W 8th Ave
Box 25127
Lakewood, CO 80225
(303)236-9427

Regional Forester
U.S. Forest Service
324 25th St.
Ogden, UT 84401
(801)625-5605

Regional Forester
U.S. Forest Service
Printing and Reproduction Section, Room 548
630 Sansome Street
San Francisco, CA 94111
(415)705-2870

Regional Forester
U.S. Forest Service
333 SW First
Portland, OR 97204-3304

Regional Forester
U.S. Forest Service
1720 Peachtree Road, NW
Atlanta, GA 30367
(404)347-4177

Regional Forester
U.S. Forest Service
310 W. Wisconsin Avenue
Milwaukee, WI 53203
(414)297-3693

Regional Forester
U.S. Forest Service
P.O. Box 21628
Juneau, AK 99802-1628
(907)586-8863

U.S. Bureau of Reclamation (USBR)
Engineering and Research Center
P.O. Box 25007
Denver, CO 80225
(303)236-8098

USBR Regional Offices:

Pacific Northwest Region
Federal Building
550 W. Fort Street, Box 043
Boise, ID 83724-0043
(208)334-1938

Mid-Pacific Region
Federal Office Building
2800 Cottage Way
Sacramento, CA 95825
(916)978-5135

Lower Colorado Region
P.O. Box 61470
Boulder City, NE 89006-1470
(702)293-8411

Upper Colorado Region
P.O. Box 11568
Salt Lake City, UT 84147
(801)542-5592

Great Plains
P.O. Box 36900
Billings, MT 59107-6900
(406)657-6214

U.S. Geological Survey (USGS)
Mid-Continent Mapping Center
Map and Field Data Section
1400 Independence Rd
Rolla, MO 65401
(314)341-0800

U.S. Geological Survey (USGS)
Rocky Mountain Mapping Center
Map and Field Data Section
Federal Center, Building 25
Denver, CO 80225
(303)236-5825

U.S. Geological Survey (USGS)
Western Mapping Center
Map and Field Data Section
345 Middlefield Road
Menlo Park, CA 94025
(415)329-4254

U.S. Geological Survey (USGS)
Eastern Mapping Center
Mapping and Field Data Section
536 National Center
Reston, VA 22092
(703)648-6002

U.S. Geological Survey (USGS)
Earth Resources Observation Systems
(EROS) Data Center
10th and Dakota Avenue
Sioux Falls, SD 57198
(605)594-7123

U.S. Geological Survey (USGS)
EROS Applications Assistance Facility
Stennis Space Center, Bldg 101
Bay St. Louis, MS 39529
(601)688-3541

EOSAT Corporation (Landsat images and digital products)
4300 Forbes Boulevard
Lanham, MD 20706
(301)552-0537 FAX: (301)552-0507

Hughes STX Satellite Mapping Technologies
(Almaz-1 Synthetic Aperture Radar Satellite Data)
4400 Forbes Boulevard
Lanham, MD 20706-4392
(301)794-5330 FAX: (301)306-0963

SPOT Image Corporation (SPOT images and digital products)
1897 Preston White Drive
Reston, VA 22091-4368
(703)620-2200 FAX: (703)648-1813

NOAA/National Environmental Satellite, Data & Information Service
(NOAA meteorological satellite images and digital products)
World Weather Building, Room 100
Washington, DC 20233
(202) 377-2985

Appendix D

Addresses of Government Agencies Producing Maps

FEDERAL GOVERNMENT

Defense Mapping Topographic Center
4600 Sangamore Rd
Bethesda, MD 20816-5003
(301)227-2050

Federal Communications Commission
Office of Public Information
1919 M Street NW
Washington, DC 20554
(202)632-7106

Federal Railroad Administration
Office of Public Affairs, ROA-30
400 Seventh Street NW
Washington, DC 20590
(202)366-0881

International Boundary Commission
United States and Canada
1250 23rd St. NW, Suite 3405
Washington, DC 20037
(202)736-9100

International Boundary and Water Commission
United States and Mexico, United States Section
Commons Bldg. C, Suite 310
4171 North Mesa
El Paso, TX 79902-1422
(915)534-6700

Interstate Commerce Commission
Office of Public Information
12th St. & Constitution Ave. NW
Washington, DC 20423
(202)927-7119

Library of Congress
Geography and Map Division
James Madison Memorial
101 Independence Ave, SE
Washington, DC 20540
(202)707-8530

Tennessee Valley Authority
Mapping Services Branch
111 Haney Building
Chattanooga, TN 37402-2801
(615)751-6277

U.S. Army Engineer District, Chicago
111 N. Canal Street, Suite 600
Chicago, IL 60606-7206
(312)353-6400

U.S. Army Engineer District, Louisville
Post Office Box 59
Louisville, KY 40201-0059
(502)582-5639

U.S. Army Engineer District, Nashville
Post Office Box 1070
Nashville, TN 37202-1070
(615)736-7161

U.S. Army Engineer District, Omaha
215 North 17th Street
Omaha, NE 68102
(402)221-3917

U.S. Army Engineer District, Vicksburg
2101 N. Frontage Road
Post Office Box 60
Vicksburg, MS 39181-0060
(601)634-5000

U.S. Bureau of the Census
Subscriber Service Section (Pubs)
Administrative Service Division
Washington, DC 20233
(301)763-4051

U.S. Bureau of Indian Affairs
Office of Public Information
1849 Sea Street, NW
Washington, DC 20240-2620
(202)208-3711

U.S. Bureau of Land Management
Office of Public Affairs
1849 Sea Street, NW, RM 5600 MIB
Washington, DC 20240-9998
(202)208-3435

U.S. Geological Survey
Branch of Distribution
Box 25286, Federal Center
Denver, CO 80225
(303)236-7477

U.S. National Archives and Records Service
Cartographic Archives Division (NNSC)
Washington, DC 20408
(703)756-6700

U.S. National Climatic Center
Federal Building
Asheville, NC 28801
(704)259-0682

U.S. National Ocean Survey
Coastal Ocean Program
1100 Wayne Ave
Silverspring, MD 20910
(301)427-2089

U.S. National Park Service
Office of Public Inquiries, Room 3045
P.O. Box 37127
Washington, DC 20013-7127
(202)208-4621

U.S. National Weather Service
1325 EW Highway
Silver Spring, MD 20910
(301)713-0689

U.S. Soil Conservation Service
Information Division
Post Office Box 2890
Washington, DC 20013

State Highway Departments

State Capitals

Appendix E

List of Journals That Contain Articles Pertaining to the Geologic and Geomorphic History of Coasts

American Association of Petroleum Geologists Bulletin
American Journal of Science
Annals of the Association of American Geographers
Arctic and Alpine Research
Australian Journal of Science
Bulletin of the Association of Engineering Geologists
Bulletin of the International Association of Scientific Hydrology
Canadian Journal of Earth Sciences
Catena
Climatic Change
Continental Shelf Research
Earth Science Reviews
Earth Surface Processes and Landforms
Ecology
Environmental Conservation
Environmental Geology and Water Sciences
Environmental Management
EOS
Geografiska Annaler
Geographia Polonia
Geographical Journal
Geographical Review
Geography
Geo Journal
Geological Society of America Bulletin
Geology
Geomorphology
Geophysical Research Letters
The Holocene

Hydrological Sciences
Journal of Applied Meteorology
Journal of Climatology
Journal of Coastal Engineering
Journal of Coastal Research
Journal of Fluid Mechanics
Journal of Geophysical Research
Journal of Geology
Journal of the Hydraulics Division, ASCE
Journal of Hydrology
Journal of Marine Research
Journal of Meteorology
Journal of Ocean and Shoreline Management
Journal of Physical Oceanography
Journal of Quaternary Science
Journal of River Management
Journal of Sedimentary Petrology
Journal of Soil and Water Conservation
Journal of Soil Science
Journal of Waterway, Port, Coastal and Ocean Engineering, ASCE
Marine Geology
Nature
Paleoclimatology, Paleoecology, and Paleography
Photogrammetric Engineering and Remote Sensing
Physical Geography
Proceedings of the Institute of Civil Engineers
Professional Geographer
Progress in Physical Geography
Quaternaria
Quaternary Research
Quaternary Science Reviews
Remote Sensing of the Environment
Science
Scientific American
Sedimentary Geology
Sedimentology
Shore and Beach
Soil Science Society of America Proceedings
Southeastern Geology
Stochastic Hydrology and Hydraulics
Transactions of the American Geophysical Union
Transactions of the Gulf Coast Assoc. of Geological Societies
Transactions of the Institute of British Geographers
Water Resources Bulletin
Water Resources Research
Zeitschrift fur Geomorphologie

Appendix F

Field Reconnaissance for Coastal Erosion Study, Site Visit Checklist

Surveys - Profiles

- a.* Profiles obtained using bank level & tape
- b.* Two typical beach profiles - extending from low tide line to at least 30 m beyond the toe of bluff or extreme high water mark
- c.* Reference location of profiles to local survey monuments or prominent feature
- d.* Date & time of tide line measurement
- e.* Identify location of extreme high water line
- f.* Approximate dimensions of erosion area
- g.* Photographs of beach where profiles are located

Sediments/Geology

- a.* Visual classification of eroding beach and bank sediments
 - (1) Sandy beach - photos within 1 ft
 - (2) Gravel beach - photos within 2 ft
- b.* Occurrence of permafrost, ice lenses, or other frozen ground features in the project area
- d.* Location of bedrock, gravel, sand, etc.

- e.* Structure and lithologies of bedrock
- f.* Mineralogic/lithologic composition of beach material
- g.* Geomorphic features - bedrock and sediment types

Wave Climate - Erosion Description (local records & sources)

- a.* Erosion Rate
- b.* Time of year erosion occurs
- c.* Direction and magnitude of significant storms
- d.* Height, frequency, and period of storm-generated waves
- e.* Photographs of the eroding area
- f.* Possible erosion causes
 - (1) Wave action
 - (2) Tidal action
 - (3) Storm surge
 - (4) Upland drainage
 - (5) Sloughing of bluff material
 - (6) Ice action
 - (7) Thermal degradation in permafrost areas
 - (8) Uses by people, such as boat wakes and upland traffic (foot or vehicle)

Real Estate Concerns

- a.* Brief description and photographs of threatened representative structures
- b.* Estimate value of land, structures, and utilities which are considered threatened
- c.* Identify potential land available for relocation
- d.* Estimate value of land needed for relocation

REPORT DOCUMENTATION PAGE

Form Approved
OMB No. 0704-0188

Public reporting burden for this collection of information is estimated to average 1 hour per response, including the time for reviewing instructions, searching existing data sources, gathering and maintaining the data needed, and completing and reviewing the collection of information. Send comments regarding this burden estimate or any other aspect of this collection of information, including suggestions for reducing this burden, to Washington Headquarters Services, Directorate for Information Operations and Reports, 1215 Jefferson Davis Highway, Suite 1204, Arlington, VA 22202-4302, and to the Office of Management and Budget, Paperwork Reduction Project (0704-0188), Washington, DC 20503.

1. AGENCY USE ONLY (Leave blank)	2. REPORT DATE March 1993	3. REPORT TYPE AND DATES COVERED Final report	
4. TITLE AND SUBTITLE Technologies for Assessing the Geologic and Geomorphic History of Coasts		5. FUNDING NUMBERS WU 32538	
6. AUTHOR(S) See reverse.		8. PERFORMING ORGANIZATION REPORT NUMBER Technical Report CERC-93-5	
7. PERFORMING ORGANIZATION NAME(S) AND ADDRESS(ES) See reverse.		9. SPONSORING / MONITORING AGENCY NAME(S) AND ADDRESS(ES) Department of the Army U.S. Army Corps of Engineers Washington, DC 20314-1000	
11. SUPPLEMENTARY NOTES Available from National Technical Information Service, 5285 Port Royal road, Springfield, VA 22161.		10. SPONSORING / MONITORING AGENCY REPORT NUMBER	
12a. DISTRIBUTION / AVAILABILITY STATEMENT Approved for public release; distribution is unlimited.		12b. DISTRIBUTION CODE	
13. ABSTRACT (Maximum 200 words) The geologic and geomorphic history of coastal areas can be assessed using a four-part process: <ul style="list-style-type: none"> ● Thorough examination of technical literature and existing data from various archives. ● Field data collection and observation. ● Laboratory examination of samples collected in the field. ● Office interpretation of all project data, both newly collected and historic. It is vital that existing sources of data be evaluated before field studies are undertaken to prevent duplicating efforts and to guide the optimum sampling scheme. Field studies must be designed to answer basic questions about the study area: <ul style="list-style-type: none"> ● What physical processes affect the region? ● Does the underlying geology have a major influence? ● How has man modified or damaged the local environment? ● How much data can we afford to collect? 			
14. SUBJECT TERMS Coastal geology Coastal studies Geologic data		Geomorphology Oceanographic instruments	
17. SECURITY CLASSIFICATION OF REPORT UNCLASSIFIED		15. NUMBER OF PAGES 174	
18. SECURITY CLASSIFICATION OF THIS PAGE UNCLASSIFIED		16. PRICE CODE	
19. SECURITY CLASSIFICATION OF ABSTRACT		20. LIMITATION OF ABSTRACT	

(Continued)

6. AUTHORS (Continued).

Andrew Morang
Joann Mossa
Robert Larson

7. PERFORMING ORGANIZATION NAME(S) AND ADDRESS(ES).

USAE Waterways Experiment Station
Coastal Engineering Research Center
3909 Halls Ferry Road
Vicksburg, MS 39180-6199

Department of Geography
University of Florida
Gainesville, FL 32611

USAE Waterways Experiment Station
Geotechnical Laboratory
3909 Halls Ferry Road
Vicksburg, MS 39180-6199

13. ABSTRACT (Continued).

- Do we have the knowledge, ability, managerial skill, or money to properly analyze the data we want to collect at the project site?
- Is it more important to conduct a long-term sampling program or a shorter, more intensive program?

Coastal scientists **must** be aware of how historic data were collected, and what assumptions and procedures were used by the original field technicians and analysts. The quality of historic data may vary from excellent to worse than useless.

The use of instruments in the coastal zone is far from straightforward; incorrect use of instruments may lead to erroneous results because the wrong parameters may be monitored. Coastal engineers are urged to consult specialists in the field to help plan and conduct field studies. The analysis of contemporary coastal data is difficult and also requires the skills of specialists with experience in the particular types of instruments and methods that have been used.

Destroy this report when no longer needed. Do not return it to the originator.

DEPARTMENT OF THE ARMY

WATERWAYS EXPERIMENT STATION, CORPS OF ENGINEERS

3909 HALLS FERRY ROAD

VICKSBURG, MISSISSIPPI 39180-6199

Official Business

SPECIAL

FOURTH CLASS

U.S. POSTAGE PAID

VICKSBURG, MS

PERMIT NO. 85

287/L12/ 1

WOODS HOLE OCEANOGRAPHIC INSTITUTION

DOCUMENTS LIBRARY/CLARK 141

WOODS HOLE MA 02543-1098