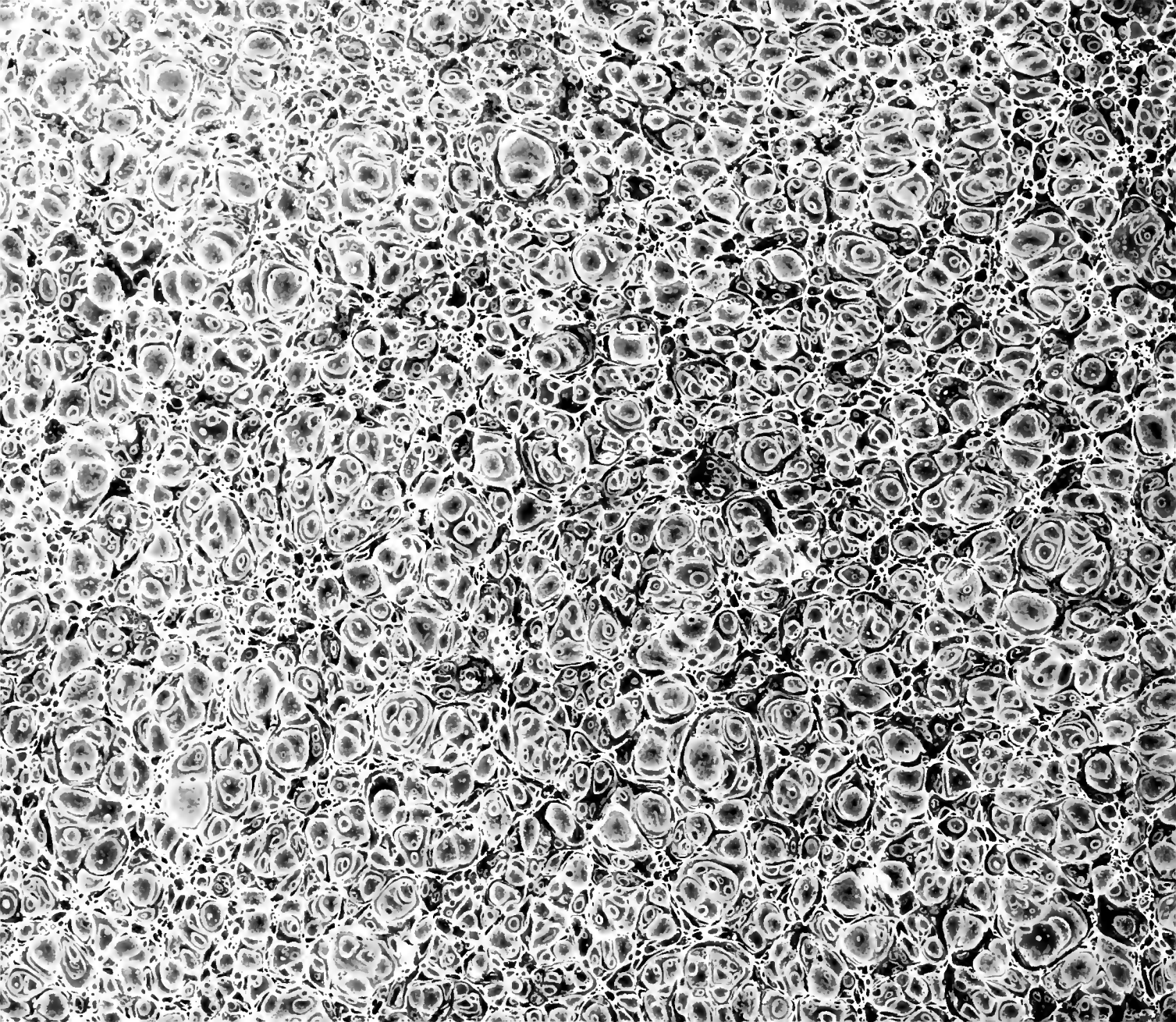
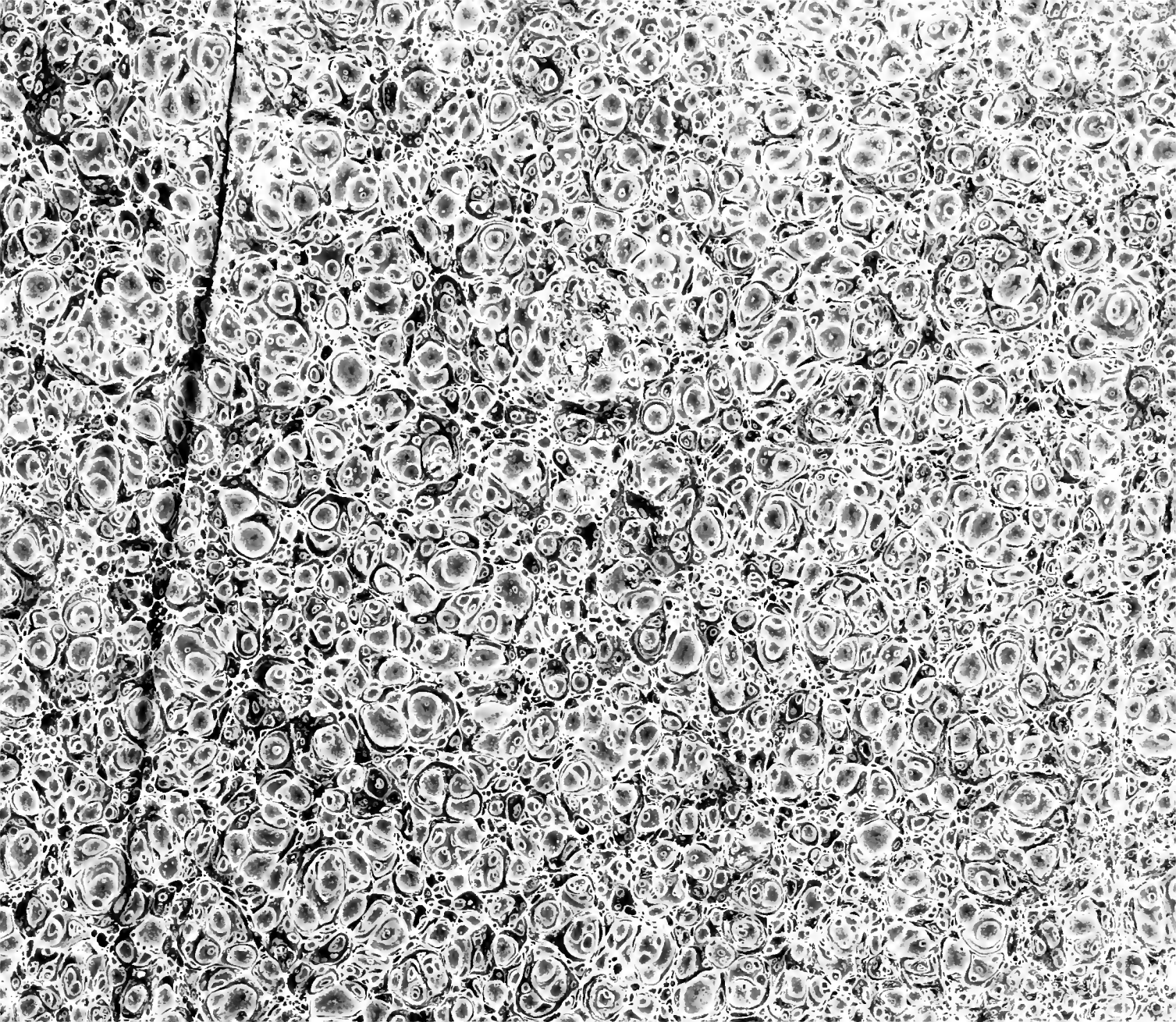
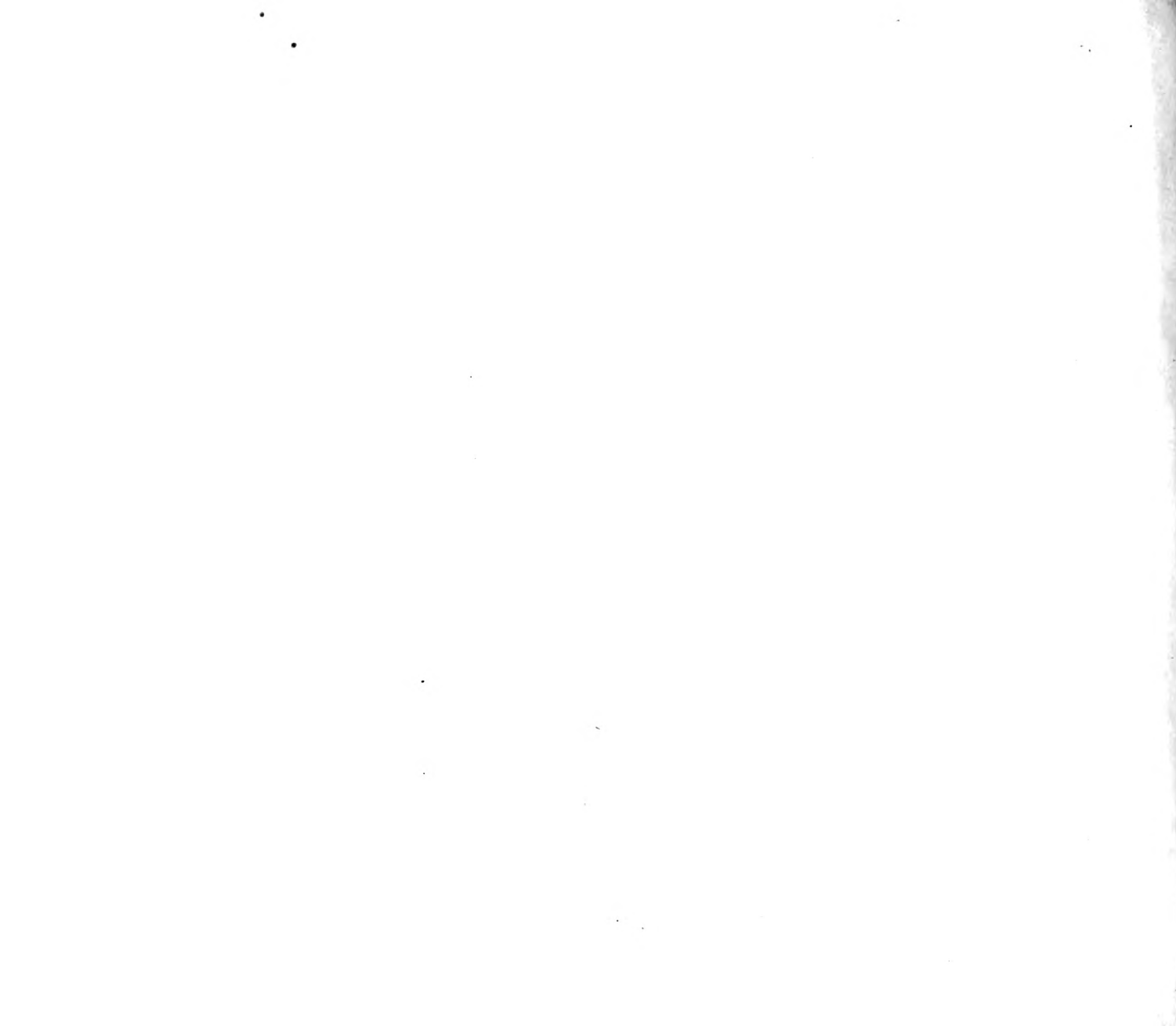


E. MOREAU







NO. 100000, par. 1. 1870
BOURNAI - MERTEN
Vander

TRAITÉ
DE LA COMPOSITION ET DE L'ORNEMENT
DES JARDINS.



PLANCHES.



A. PICHAN DE LA FOREST, Imp. de la Cour de Cassation,
Rue des Noyers, 37.

TRAITÉ
DE LA COMPOSITION ET DE L'ORNEMENT
DES JARDINS,

AVEC CENT SOIXANTE ET UNE PLANCHES

REPRÉSENTANT, EN PLUS DE SIX CENTS FIGURES,

DES PLANS DE JARDINS, DES FABRIQUES PROPRES A LEUR DÉCORATION, ET DES MACHINES
POUR ÉLEVER LES EAUX.

OUVRAGE FAISANT SUITE A L'ALMANACH DU BON JARDINIER.

CINQUIÈME ÉDITION,

entièrement refondue, augmentée de plus du double dans le texte, de 94 planches gravées,
et où tous les plans de jardins ont été changés.

Je dirai comment l'art, dans de frais paysages,
Dirige l'eau, les fleurs, les gazons, les ombrages.
(DELITE)

Paris,

AUDOT, ÉDITEUR DU BON JARDINIER,
RUE DU PAON, 8, ÉCOLE DE MÉDECINE.

MDCCCXXXIX.

Digitized by the Internet Archive
in 2010 with funding from
Research Library, The Getty Research Institute

<http://www.archive.org/details/traitedelacompo02audio>

TABLE DES FIGURES

AVEC RENVOIS AUX PAGES DU TEXTE EXPLICATIF.

Planches.	Figures.	Pages.	Planches.	Figures	Pages	Planches.	Figures	Pages.
1	1,2	25	8	7,8	56,65	22 bis		79
	5	26		9 à 15	67	25	1,2,6	215
	4,5	27	9	1	67		3,4	56,112
	6,7	28		2,5	68		5	112
	8,9	29	10	1,2	68	24	1,2,4	216
	10	50		5,4	69		5	102
	11	51	11,12		69		5,6	57
	12	115	15		70	25	1 à 4	97
2	1	54	14		71,216		5	217,218
	2	48	15		75	26	1,2	112
5	1	46	16		76		5	100
	2	47	17	1	75		4	112,215
4		47		2	75,128		5	216
5	1	52		5 à 5	76	27	1	102
	2	55	18	1	76		2,4,5	112
6		55		2	77		5	158
7	<i>a, e, f, g</i>	55	19	1	49		6,7	57
	1 à 4	97		2	85		8	157
8	1	56,65	20		84	28	1 à 15	105
	2 à 6	56	21,22		85		14	102

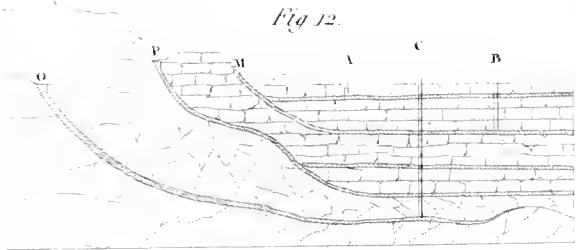
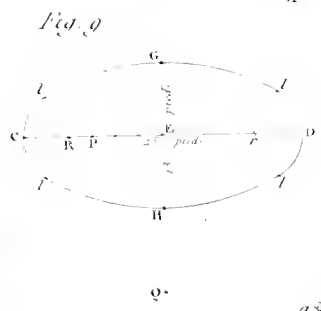
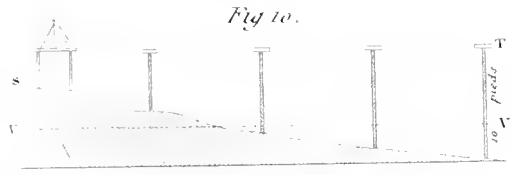
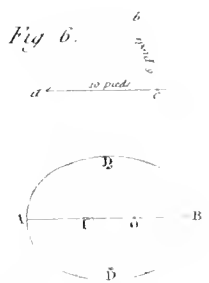
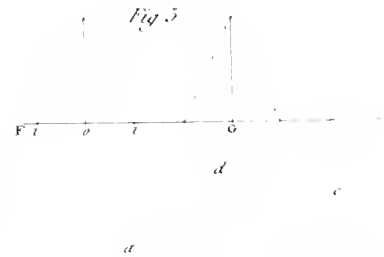
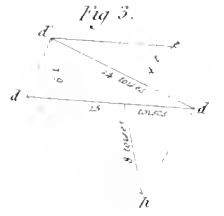
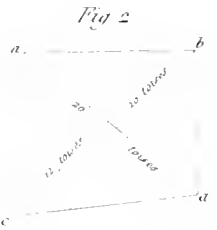
Planch.	Figures.	Pages.	Planches.	Figures	Pages	Planches	Figures	Pages
29		97	46	1	102, 166	57	5	175, 177
30	1 à 10	147		2	166		6, 7	175
	11 à 11	148	47	1, 2	102, 166		8, 9	177
31	1 à 5	118		3, 4	166	58	1, 2, 5	171
	1 à 10	215	18		102, 166		5, 4	171, 177
32		148	49	1, 5	102, 166		6	172, 177
33	1	154		2, 4, 5, 6	166		7, 8	172, 176
	2, 5	155	50	1, 2	102, 166		9	177
34	1	154		3 à 5	166	59	1	175
	2 à 4	155	51	1 à 4	166		2	172
35	1	156		5 à 7	166, 177		5	172, 177
	2	157	52		166		4	175, 176
	5 à 7	158	55		168		5	175
36		155	54	7 à 16	168	60	1, 4	175, 177
37		156		17	215		2, 5, 5, 6	175
38		159		18	Cette figure est un détail représentant la décoration d'un pignon saillant de cottage, comme on en voit dans les pl 56, 57, 60.		7	171
39		160				61		174
40	1, 2, 5	35, 162	55	1	174	62		174, 175
	4 à 10	162		2, 5	172, 177	65	1 à 19	177
41		162	56		172		20 à 26	178
42		165	57	1	174	64		178
43		161		2	171	65		178
44		165		5	175	66	1	178
45		166		4	172, 176		2	179

— VII —

Planches.	Figures.	Pages.	Planches.	Figures.	Pages.	Planches.	Figures.	Pages.
67		177	90	4	205	103	1 à 5	210, 220
68		179	91	1 à 8	205		6	220
69	1	195		9	206	109		209
	2	196		10, 10 bis, 11	220	110		210
70		196	92		82, 206	111	4	69, 209
71	1, 2, 4	196	95		206		2, 5	176, 209
	5	197	94		206, 212		4, 5, 6	209
72		196	95	4	206, 212	112	1, 4, 5, 6	210
75		197		2 à 5	206		2	195
74	1, 2	198	96	1, 5, 4	207		5	151, 195
	5, 4	199		2	208	115	1, 5	151, 211
	5	200	97	4, 5	151, 208		2, 4, 5, 6	211
75		199		2, 4 à 8	208	114	1, 2, 4	211
76 à 78		200	98		208		5	209, 211
79		196	99	4	208	115	4	211
80		197		2	102, 207		2	151, 210
81	1, 2	205		5	207	116	1, 5, 4	211
	5, 4	197		4	151, 208		2	151, 210
82		202	100	1, 2	207	117	1, 2, 4	211
85	1 à 4	205		5	99, 207		5	210
	5, 6	204	101	4	207, 212	118, 119		211
84 à 87		205		2	207	120		211, 212
88, 89		204	102		207	121, 122		211
90	1, 2, 5	204	105 à 107		209	125, 124		212

Planches.	Figures.	Pages.	Planches.	Figures.	Pages.	Planches.	Figures.	Pages.
125	1 à 6	215	158	7	188	150	5 à 12	219
	7	215		8	189, 190		15 à 15	155
126, 127		215		9	190	151, 152		155
128, 129		214		11	191	155	1	155
150	1 à 5	211	159, 140		217		2	154
	4 à 6	149	141	1 à 5	179		5	154, 140
151		185		4	211	154	1	156
152		184		5	118		2, 5	157
155	1 à 5	184		6	214		4, 5	141
	4	185		7	209		6, 7	142
154		184		8 à 11	217	155		155
155		185		12	215	156	1	155
156	1, 2	185	142	Gondoles.	217		2	156
	5	185		2	115	157	1, 2	154, 140
	4	184	145		217, 218		5	154
157	1	184	144		217, 218		4	158
	2, 5	185	145		217, 218		5	140
	4, 6	191	146		219		6	141
	5	195	147	1 Porte élégante pour l'entrée d'un casin.		158, 159		159
158	1	195		2 à 4	219	160	1	140
	2	186	148		219		2	141
	5 à 5, 10	192	149		219			
	6	189	150	1 à 4	219			

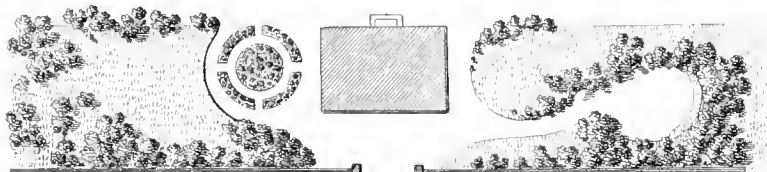
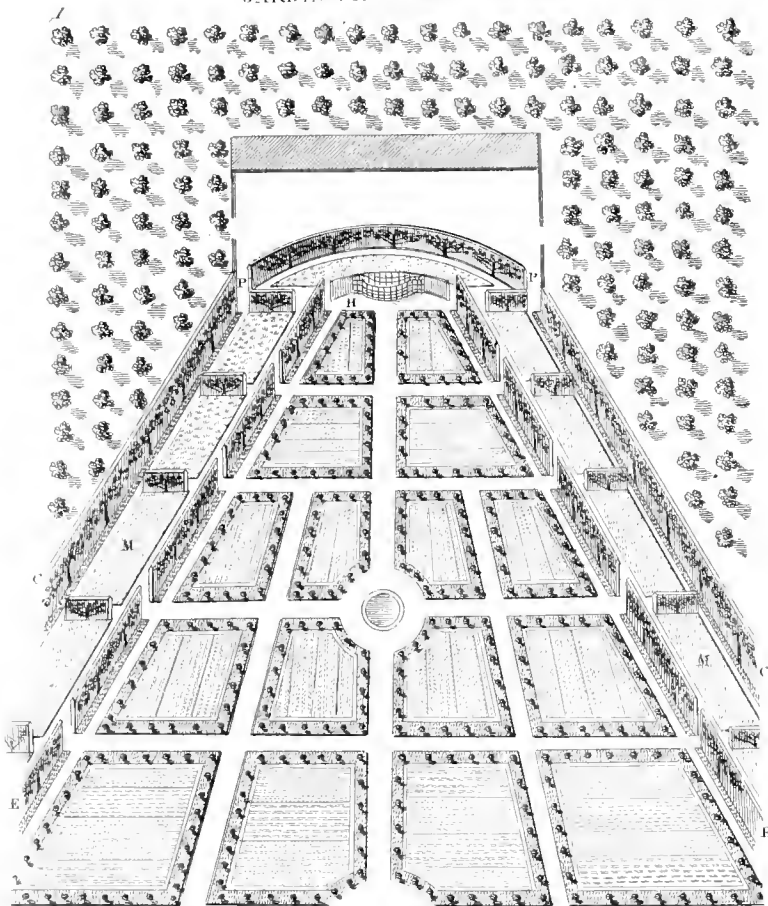
Cet ouvrage contenant une planche 22 bis,
il présente un ensemble de 161 planches.



10 toises en pades



JARDIN FRUITIER POTAGER



Architect. 1792

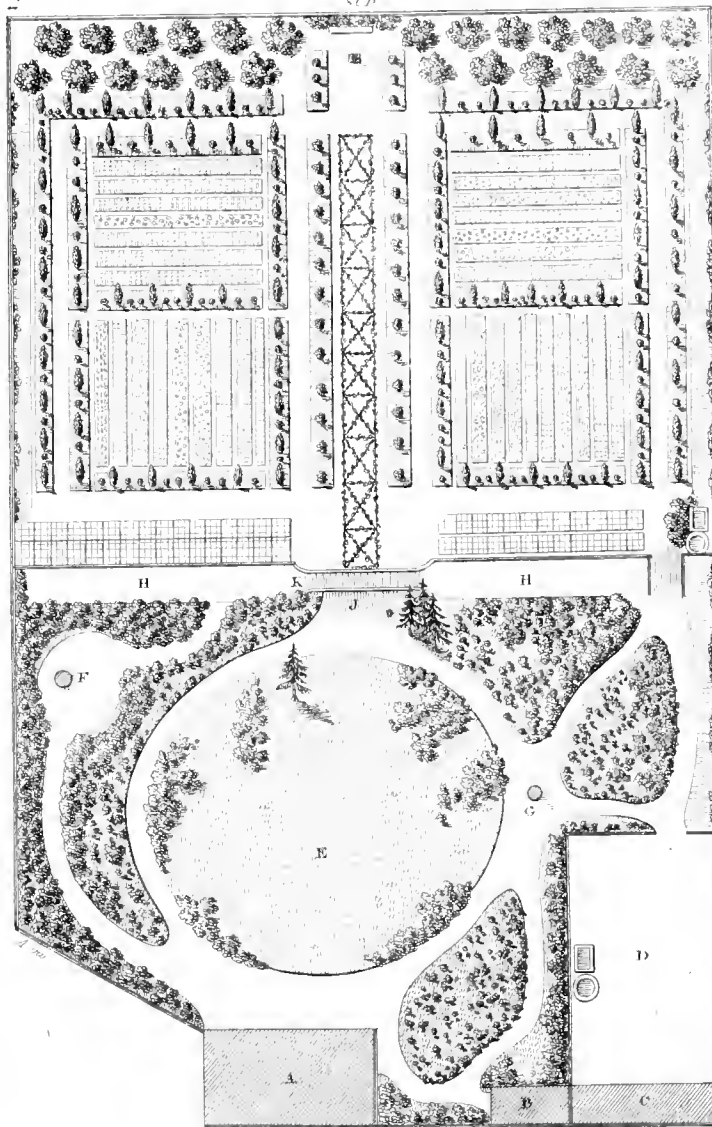
SUP

100 pieds

JARDIN MIXTE

SUP

172



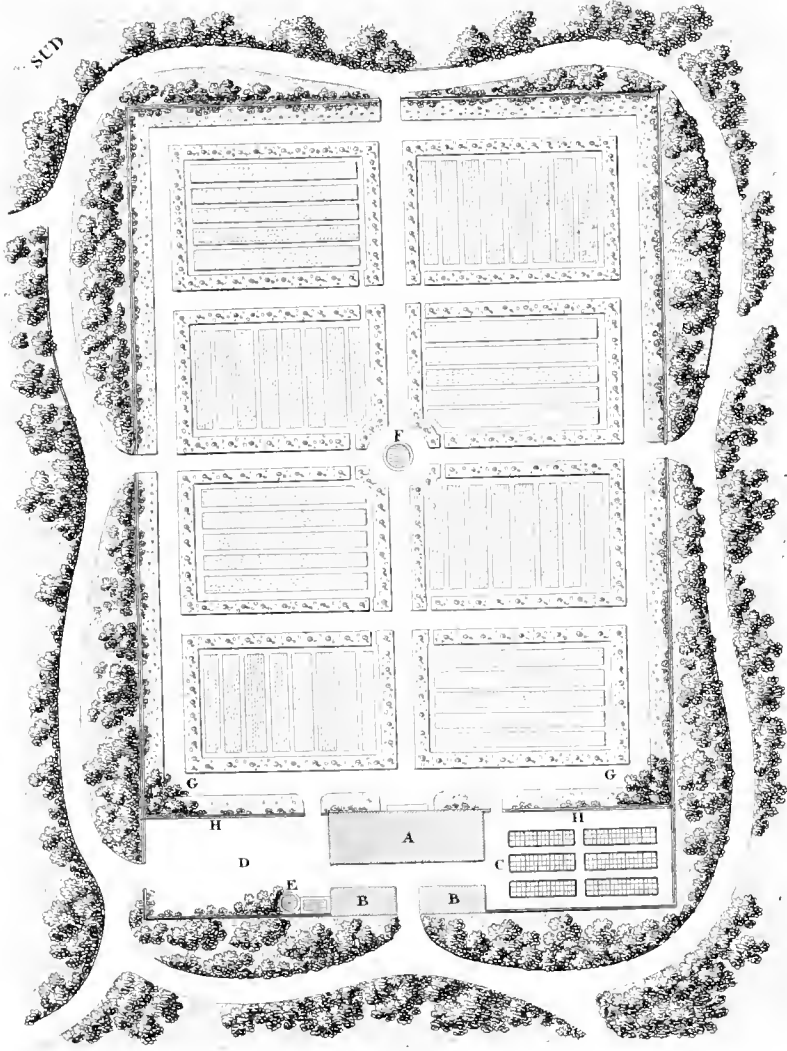
1792

Architect. 1792

60 m



JARDIN FRUITIER-POTAGER.

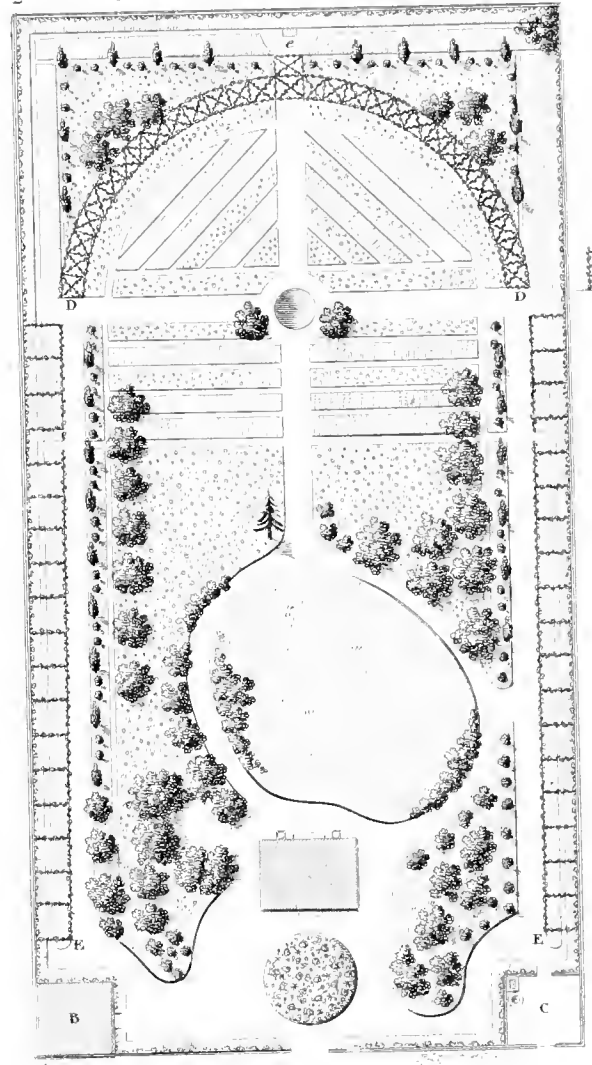


A 1700.



JARDIN FRUITIER-POTAGER ORNÉ.

Pl. 3.



A 1700.





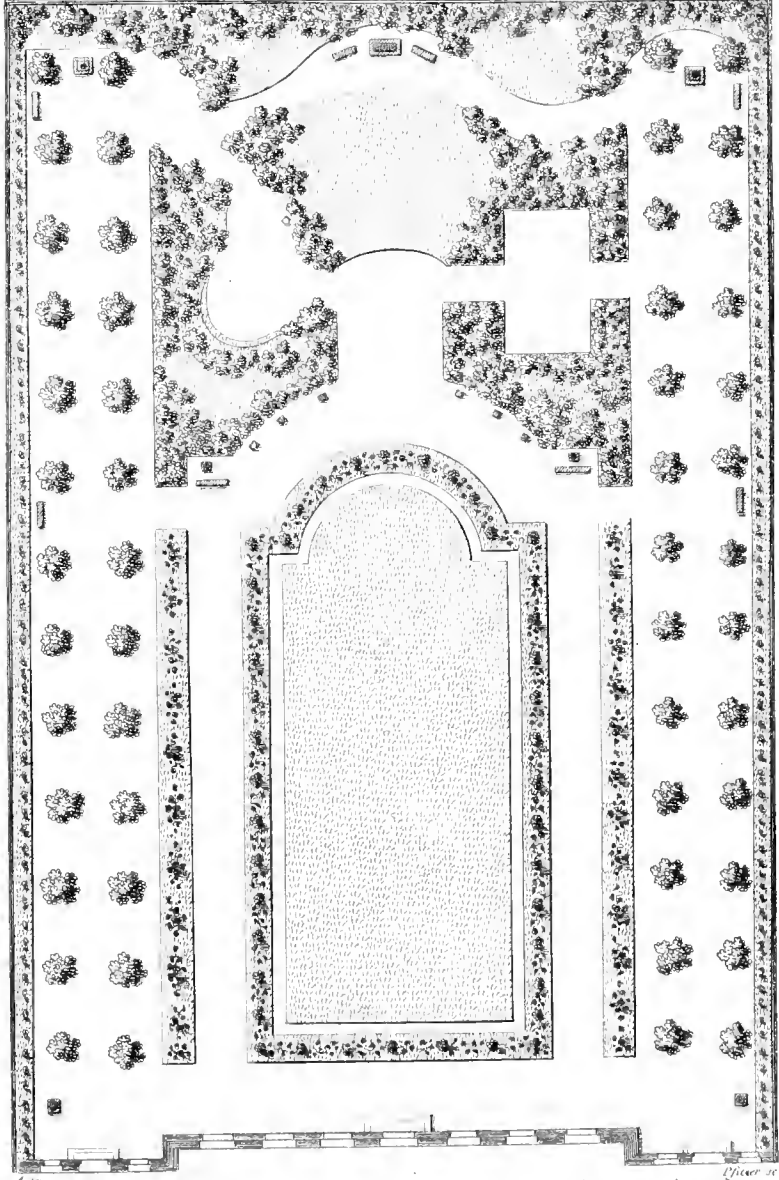
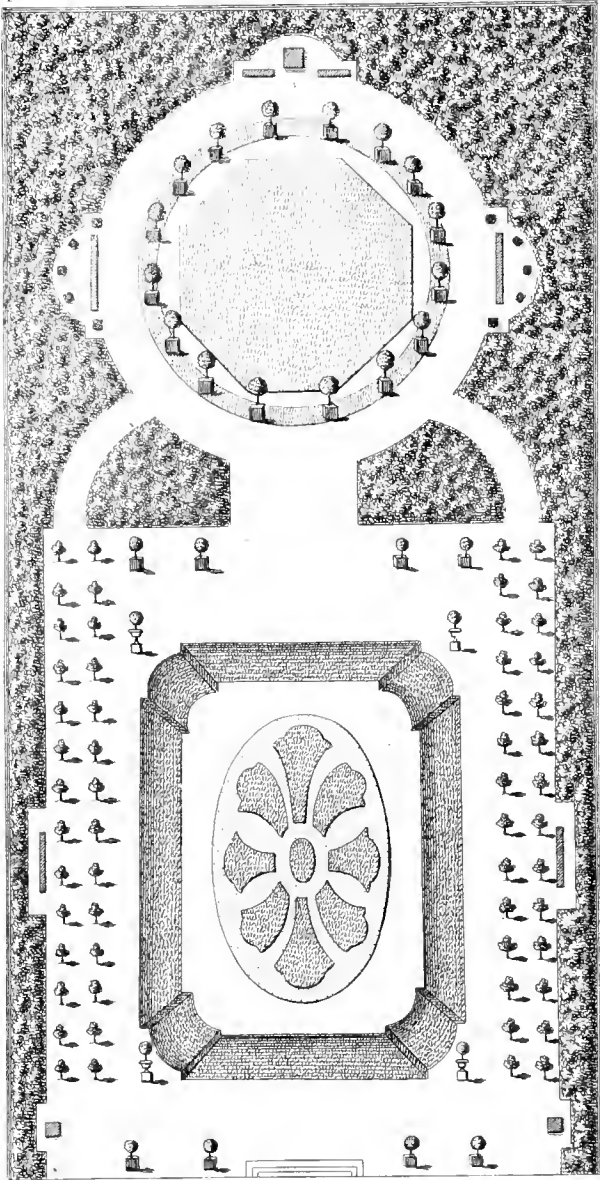


SLD

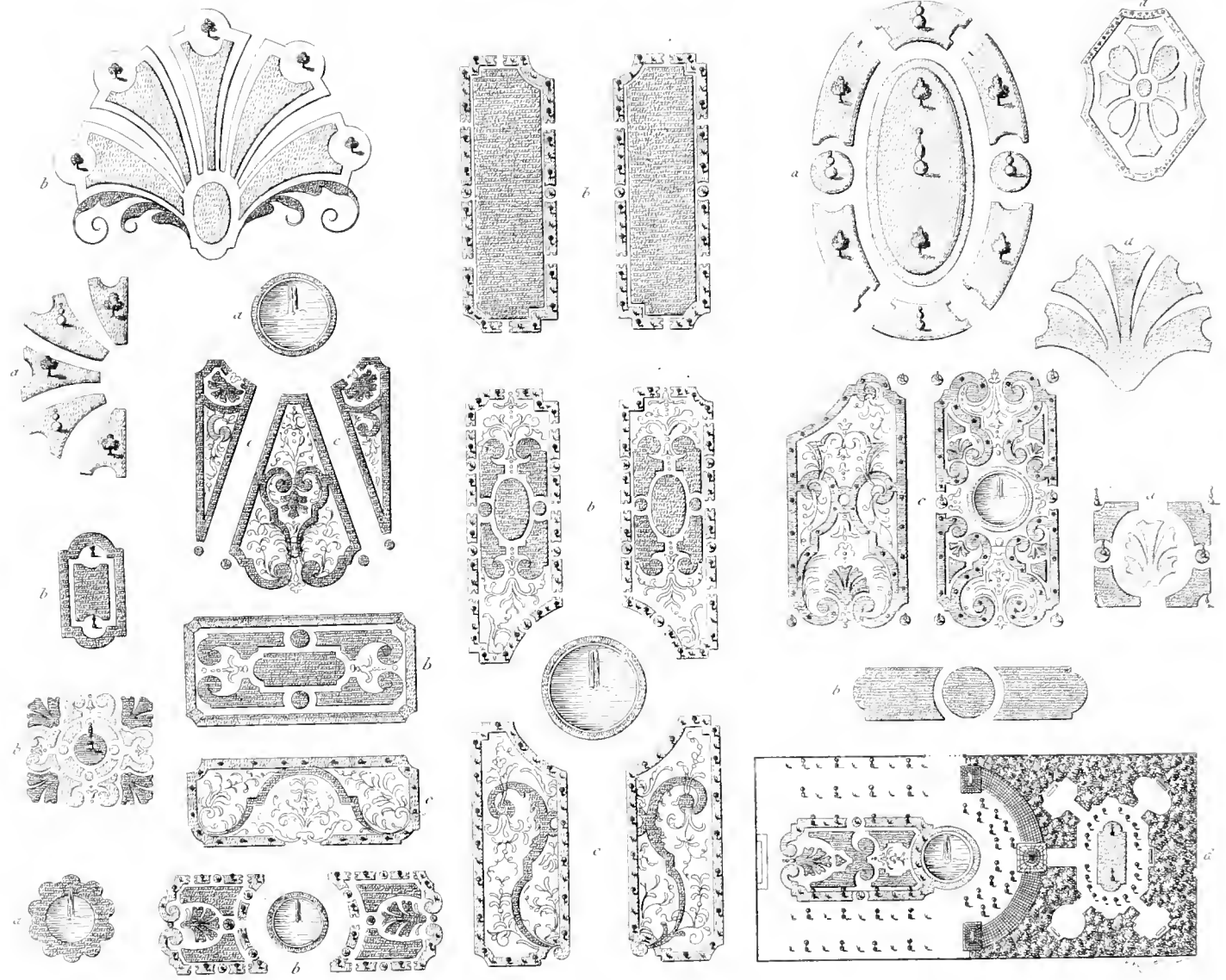
1000 feet

1 mm

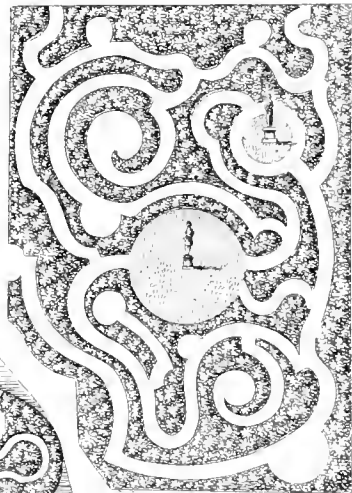
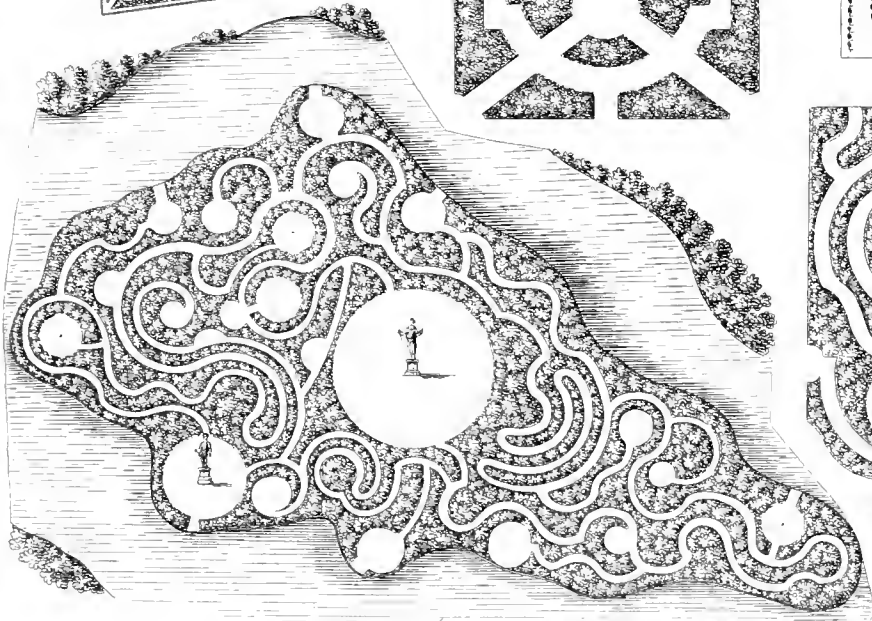
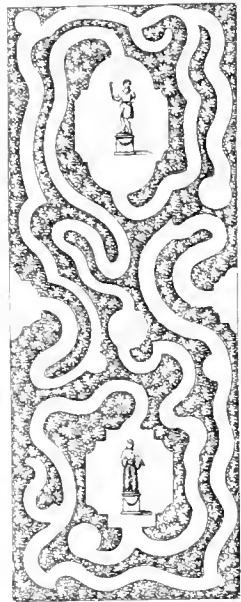
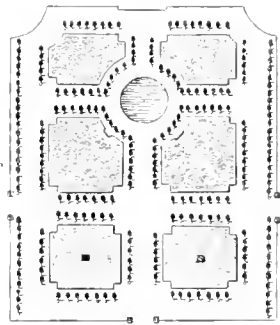
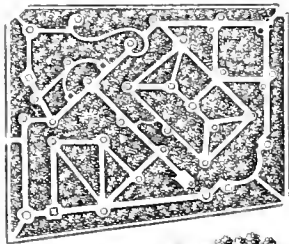
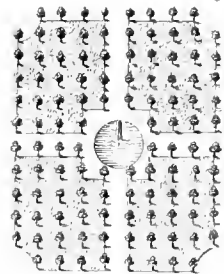
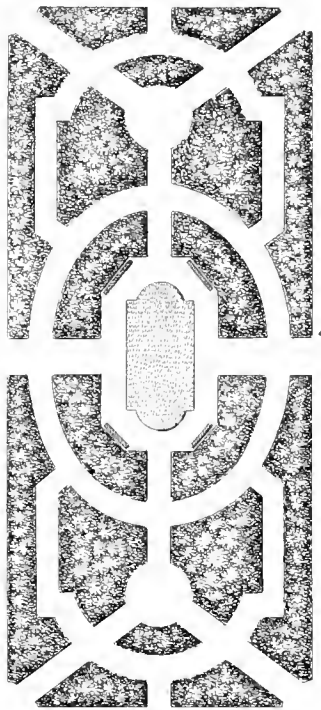
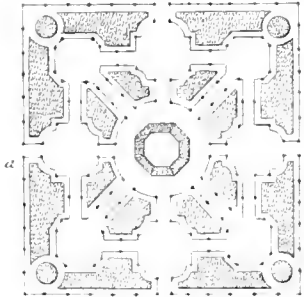
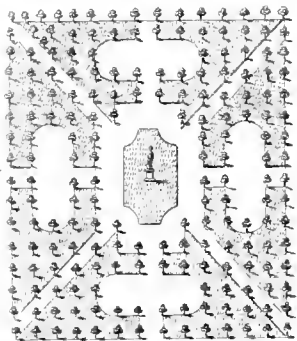










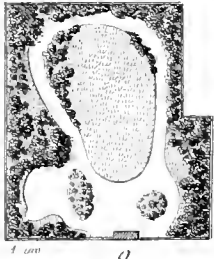


2

4

3

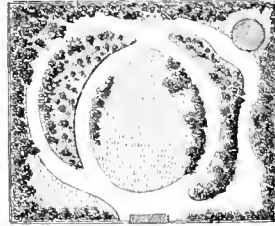




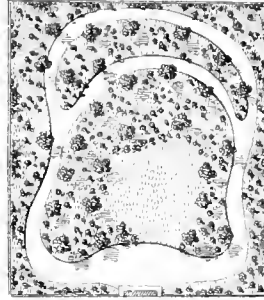
9



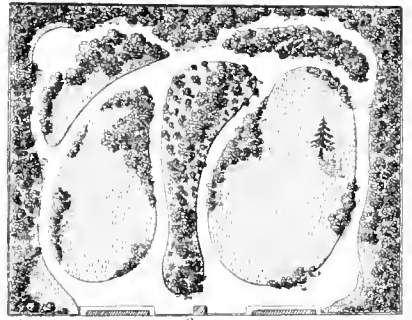
10



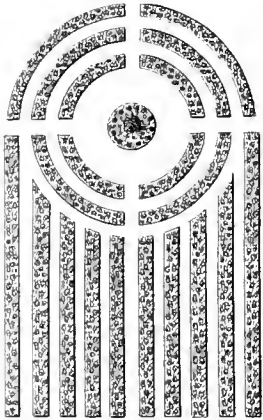
11



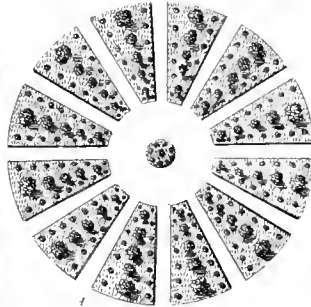
12



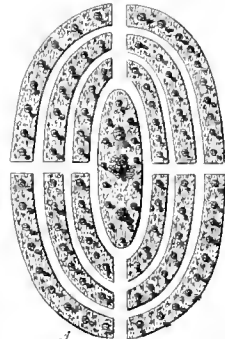
13



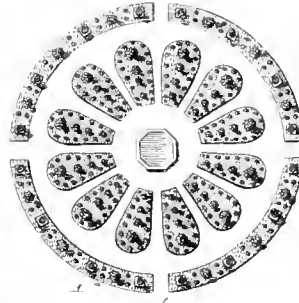
1



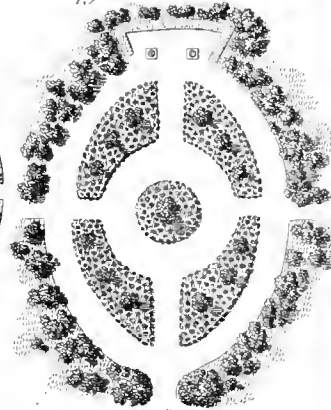
2



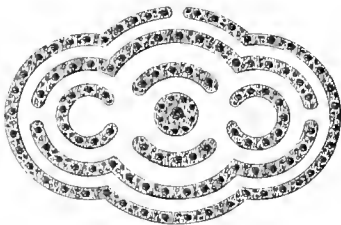
3



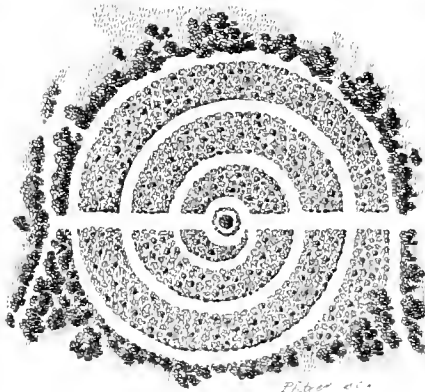
4



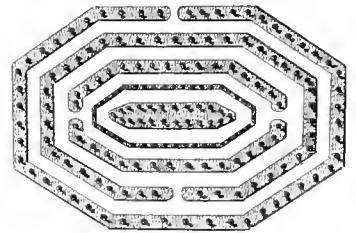
5



6



7

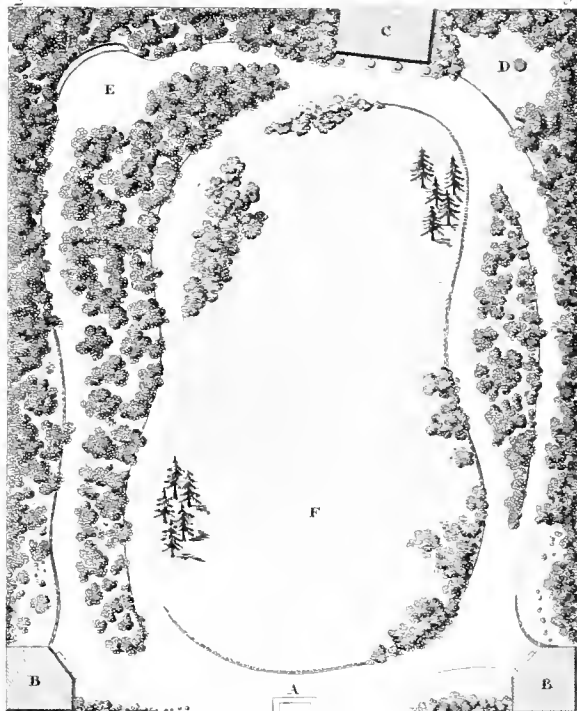


8





A 1790

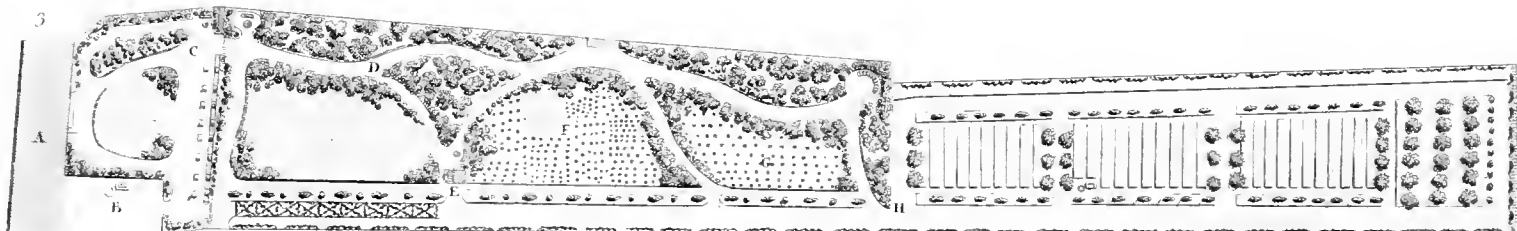


A 1790

50 pieds

50 pieds

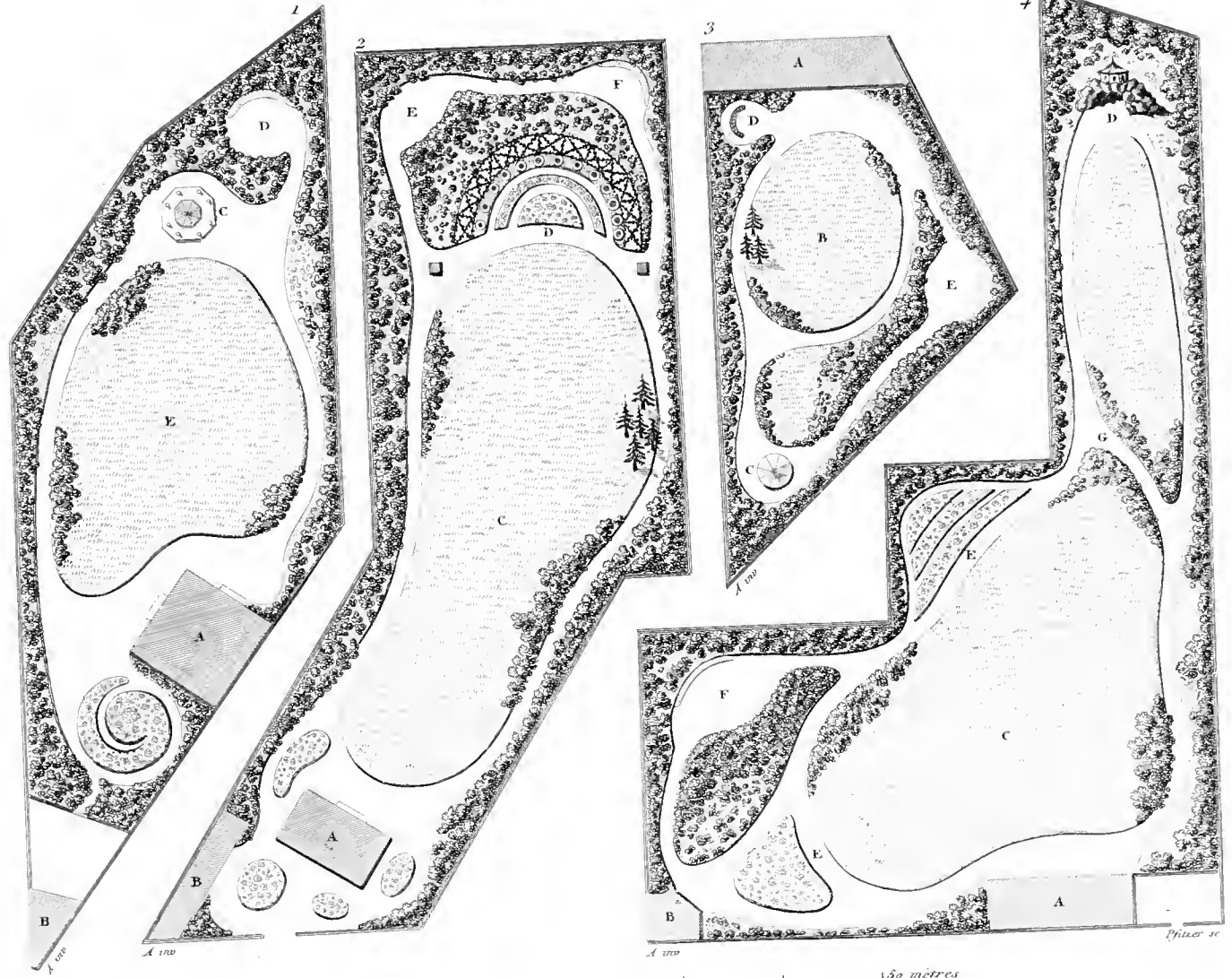
3



cuttati. 1790

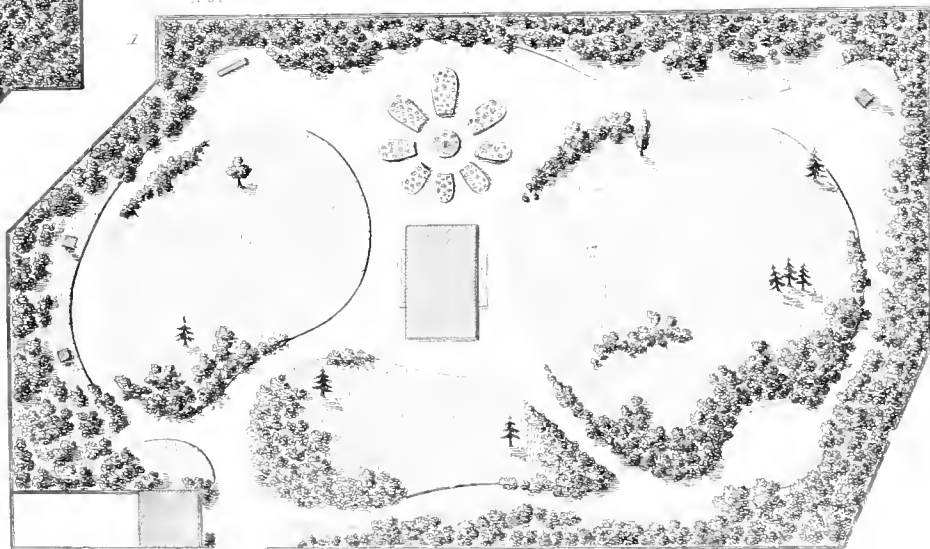
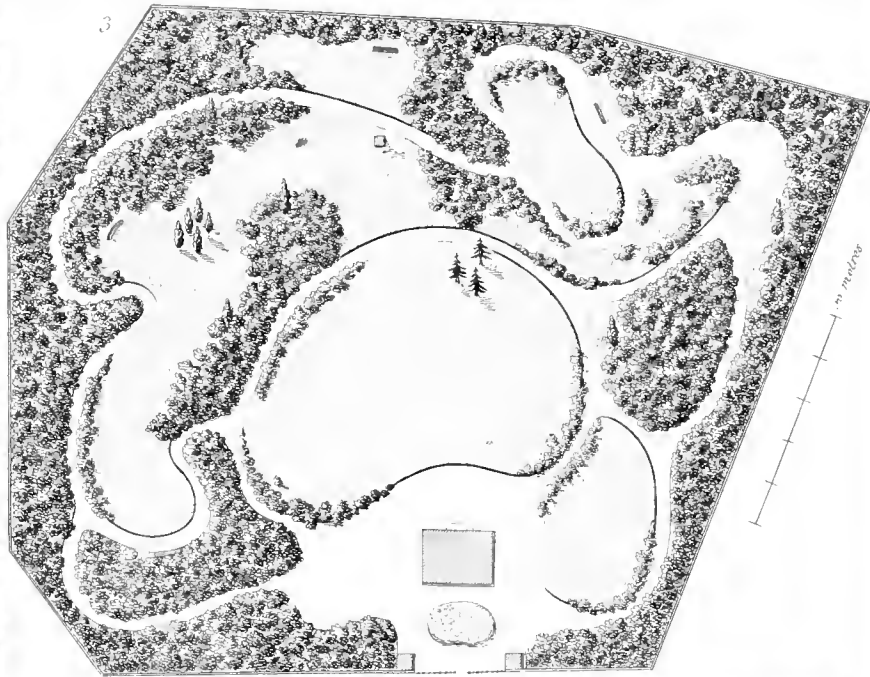
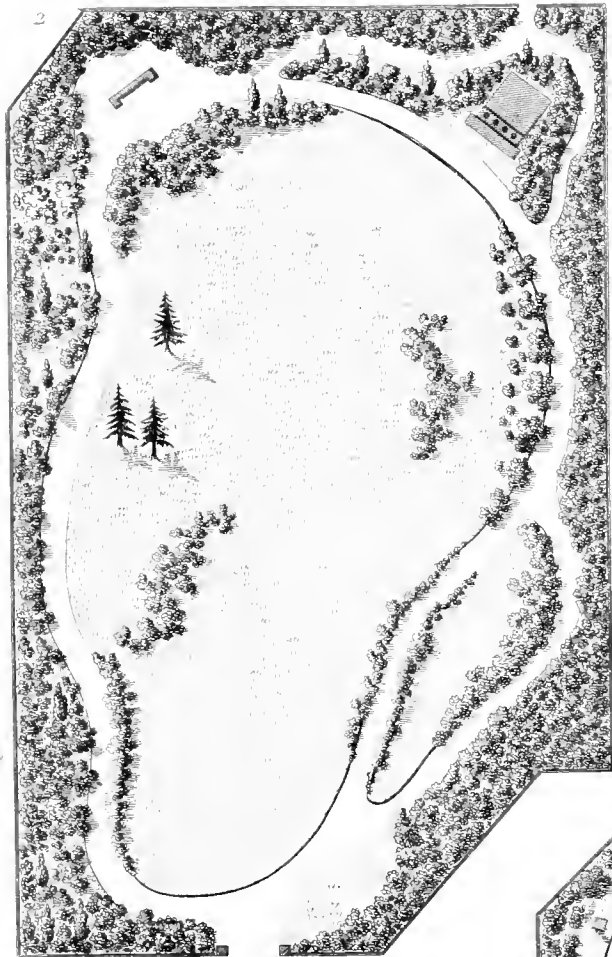
100 pieds

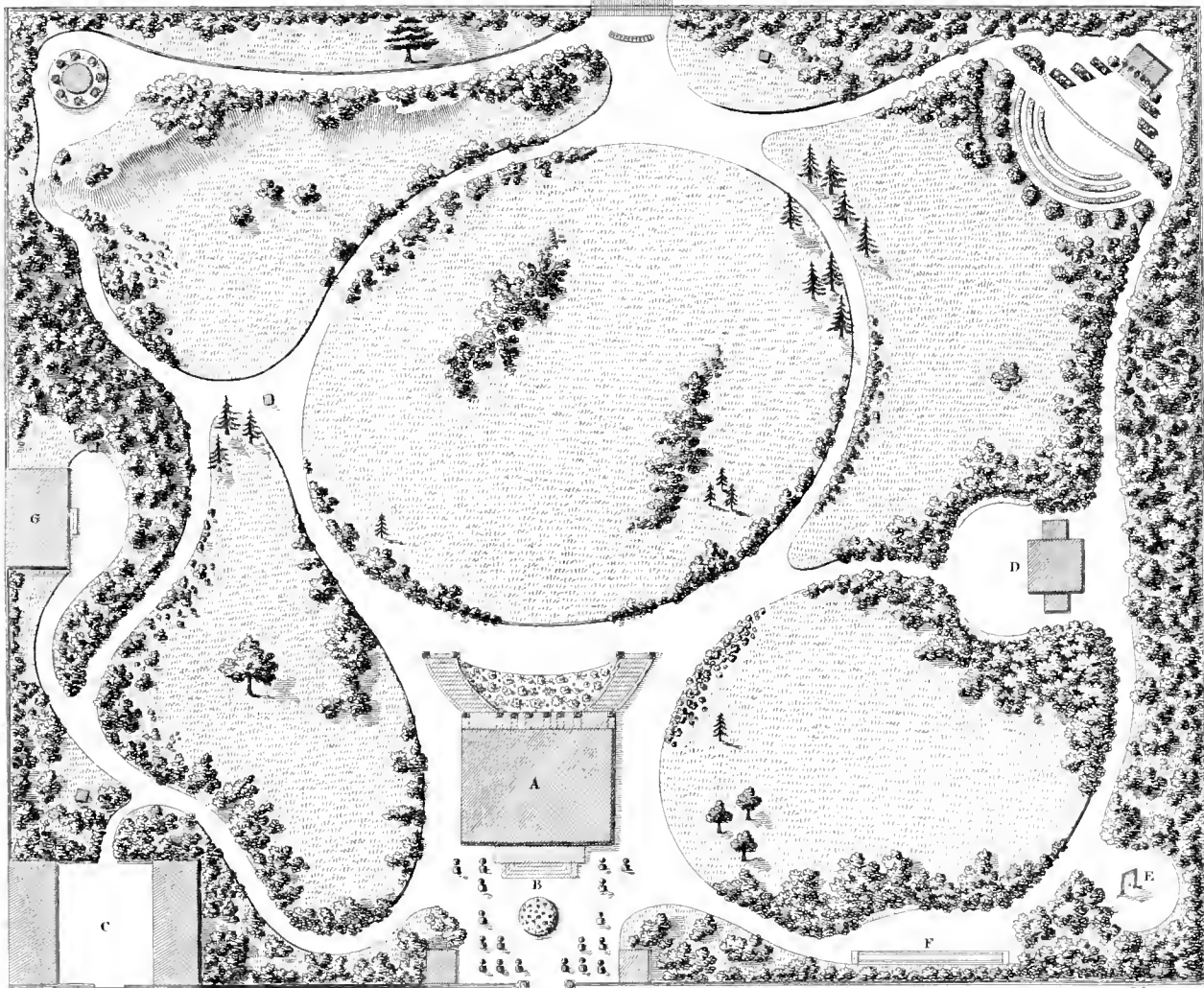




Pfister sc





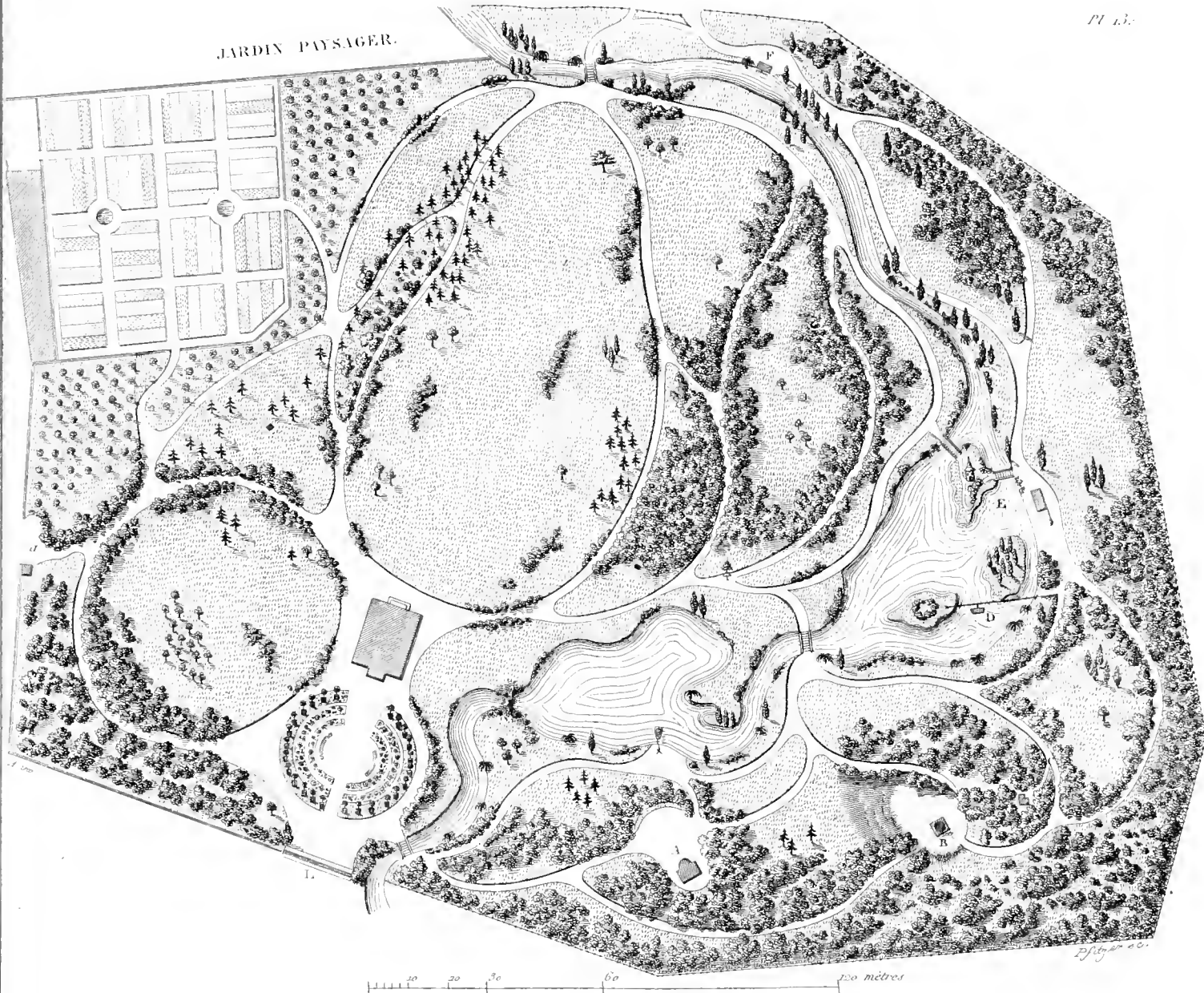


A. 1792

50 mètres



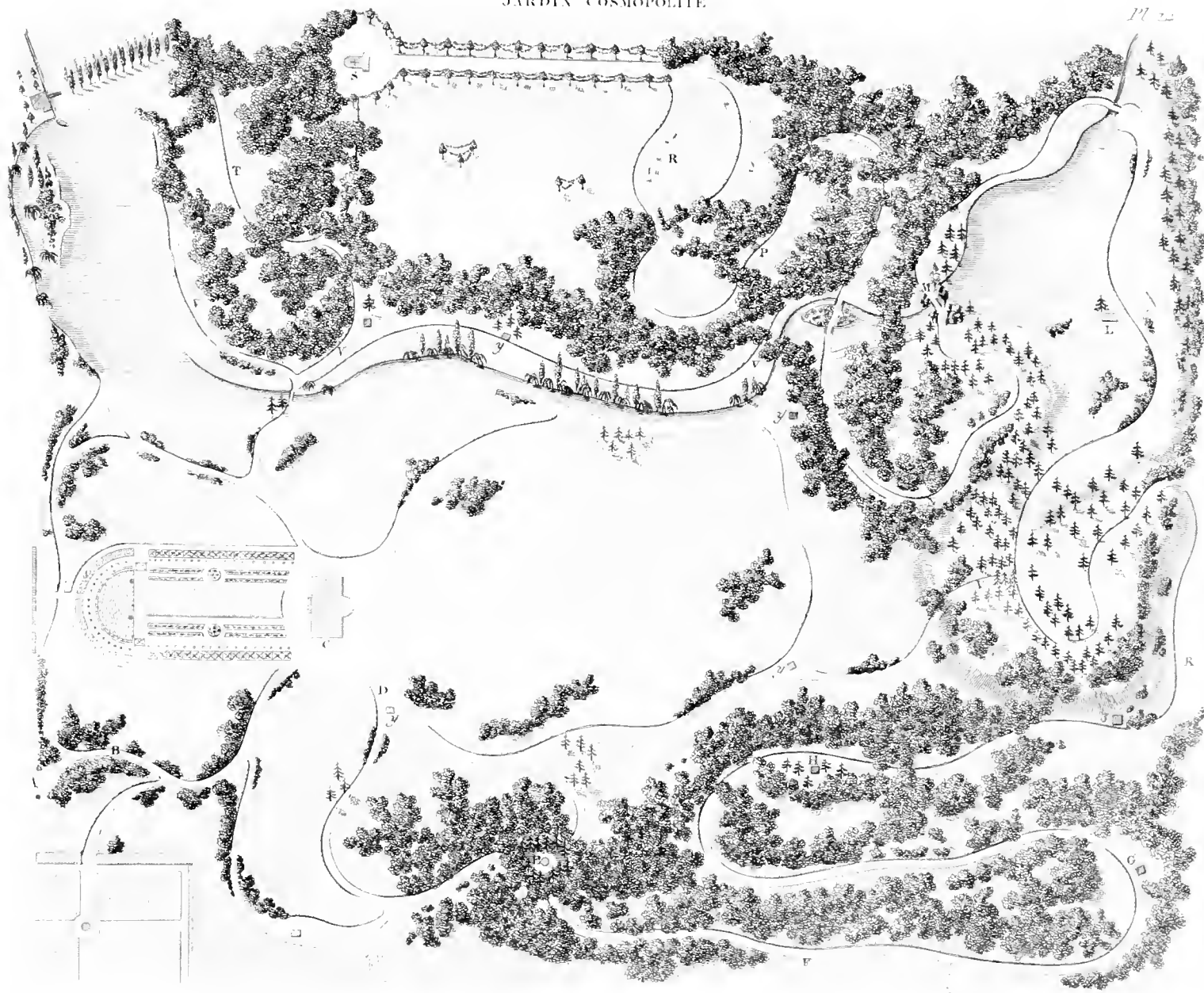
JARDIN PAYSAGER.



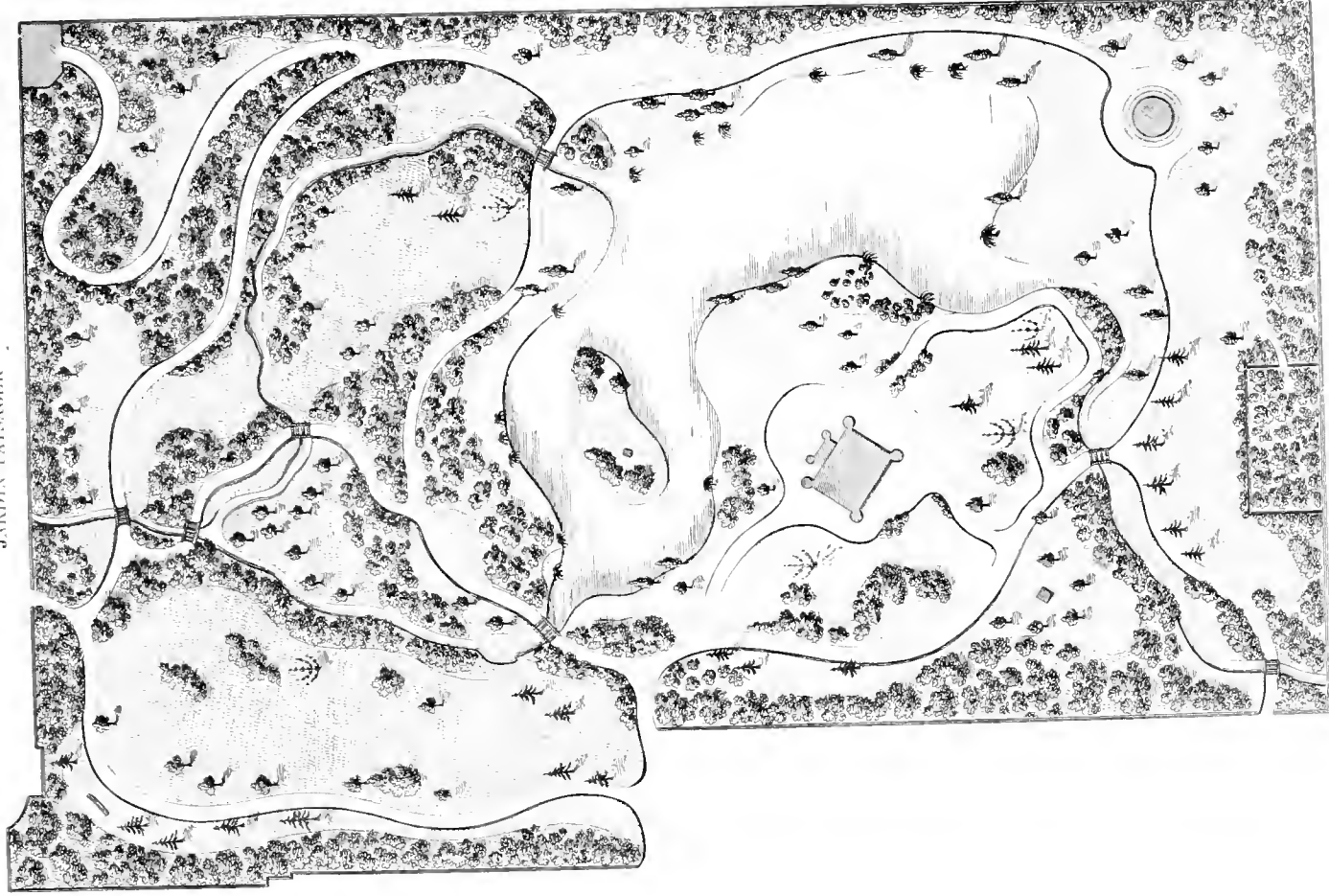
20 30 60 100 mètres

1856

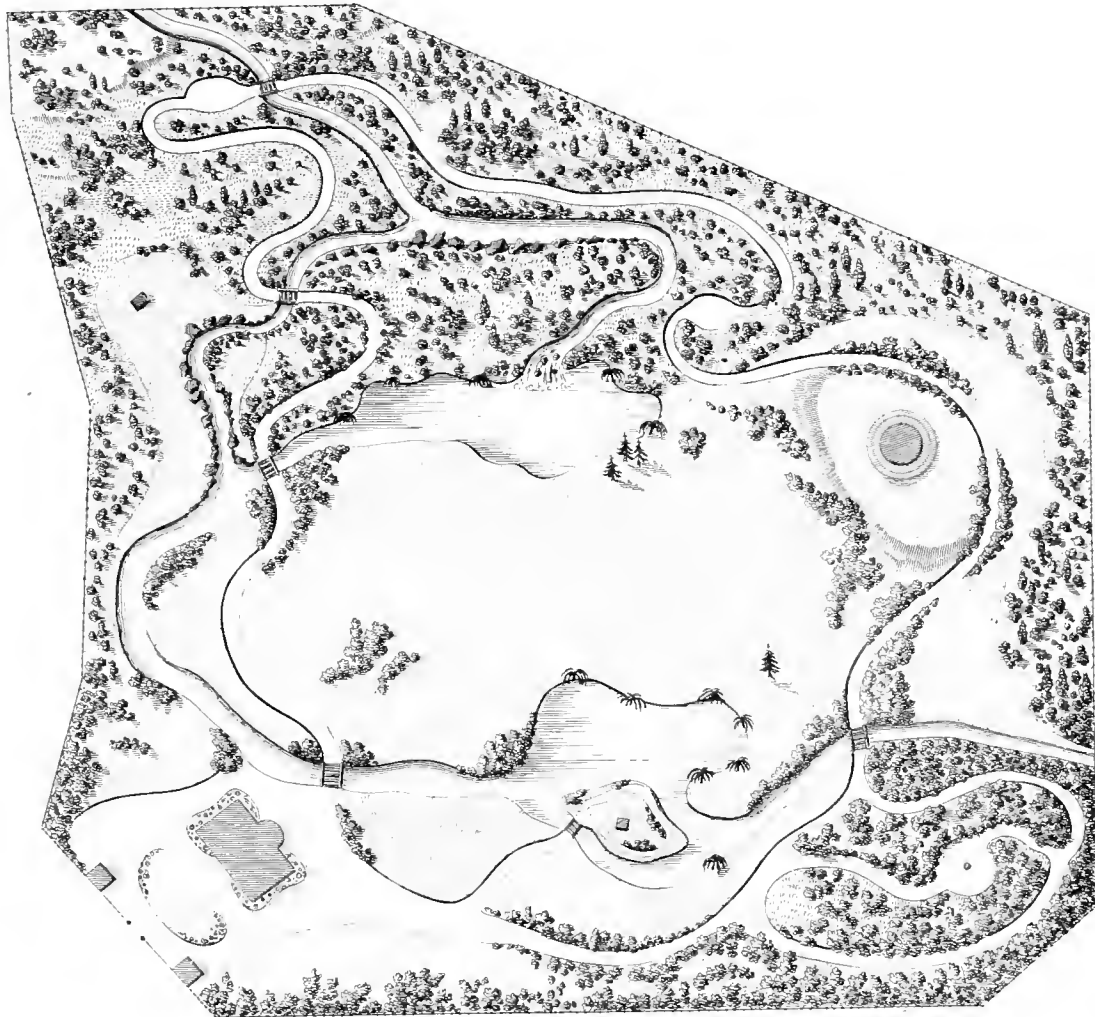






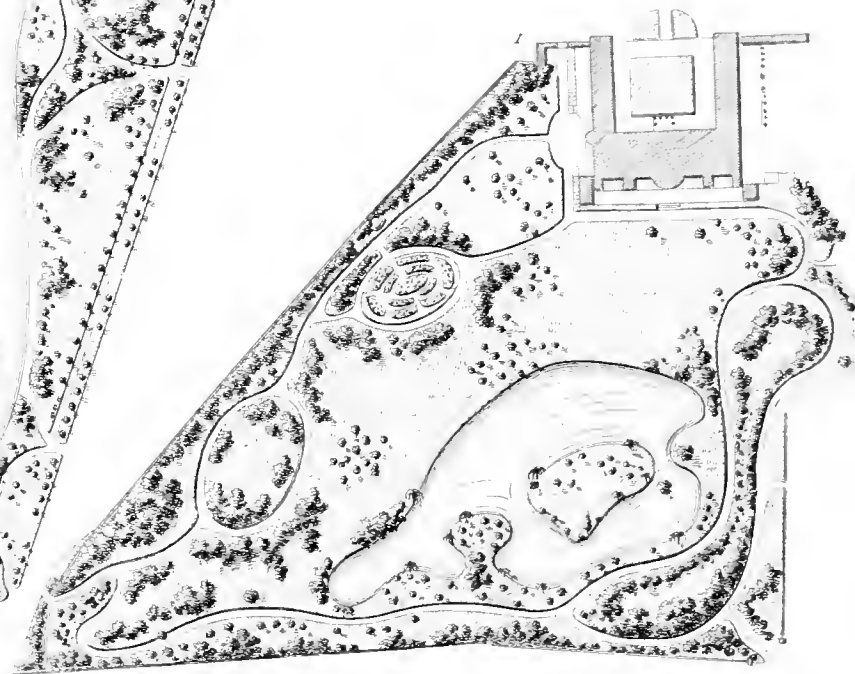
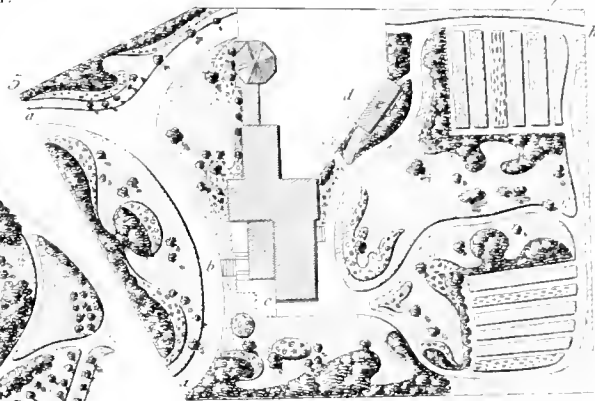
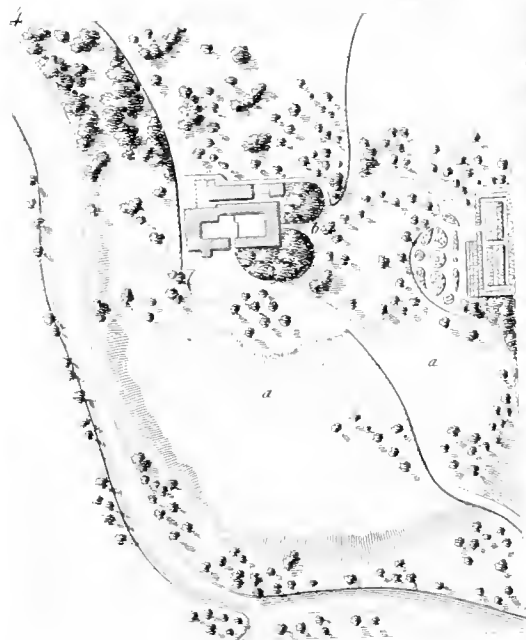
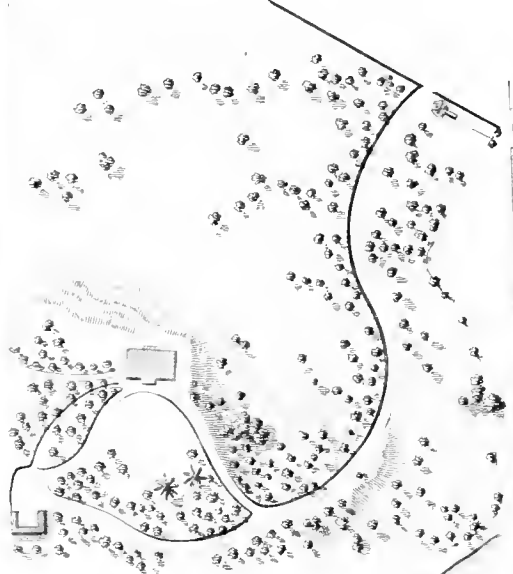




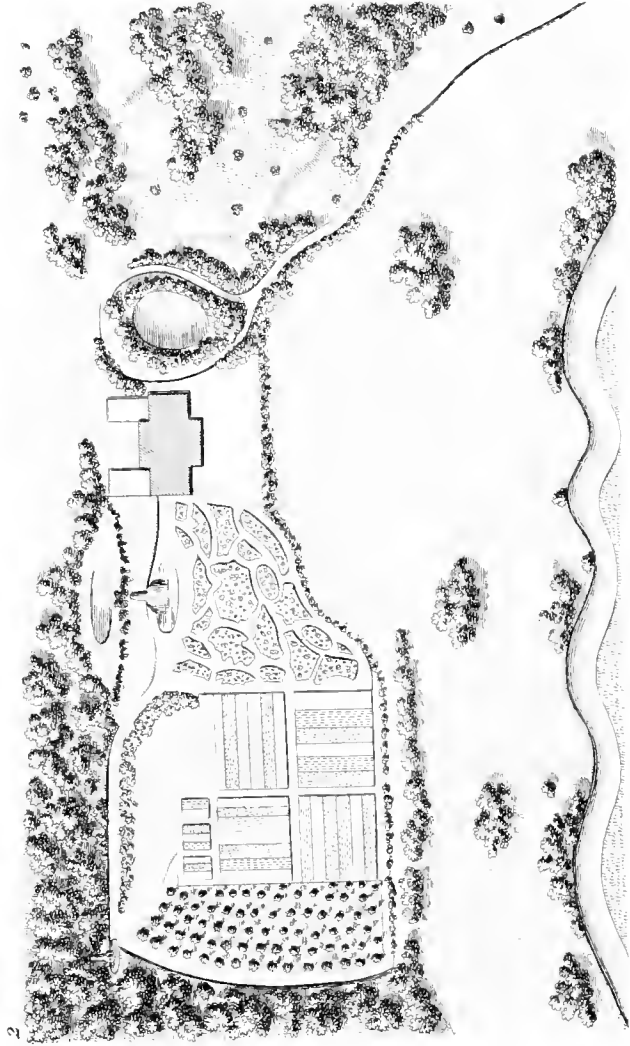
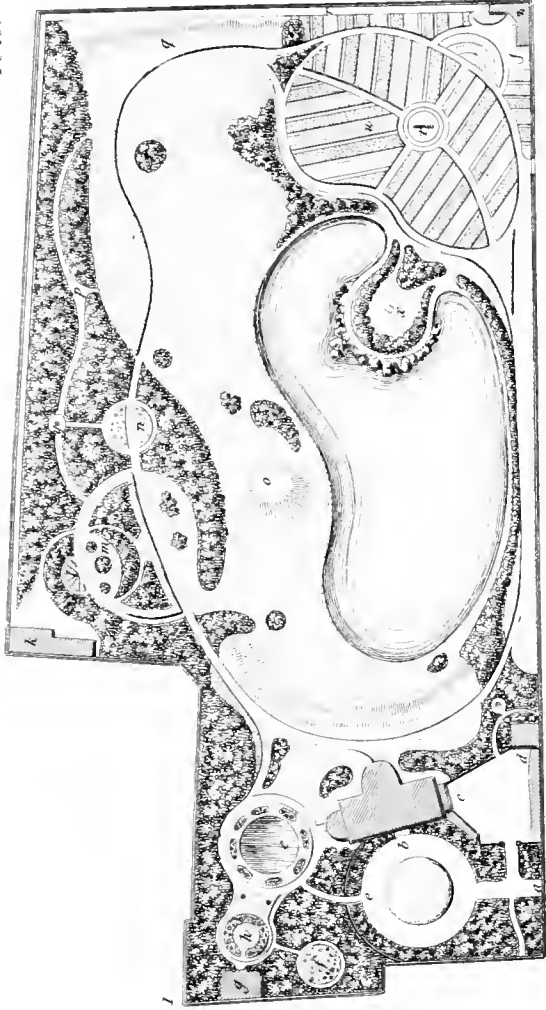


50 mètres

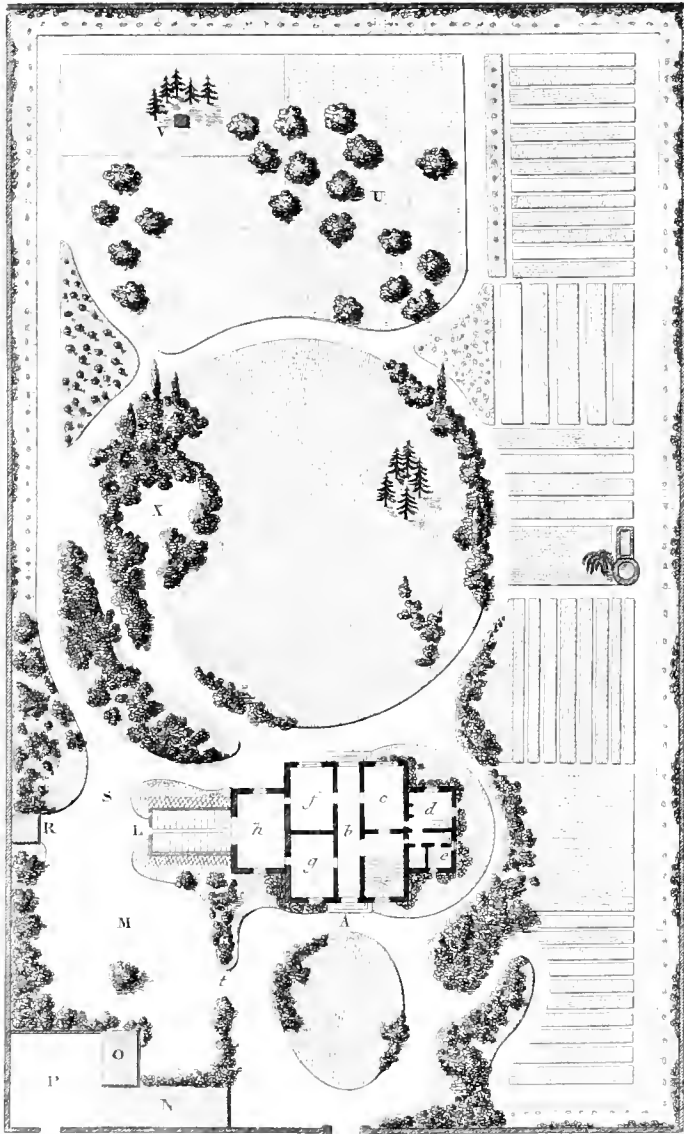






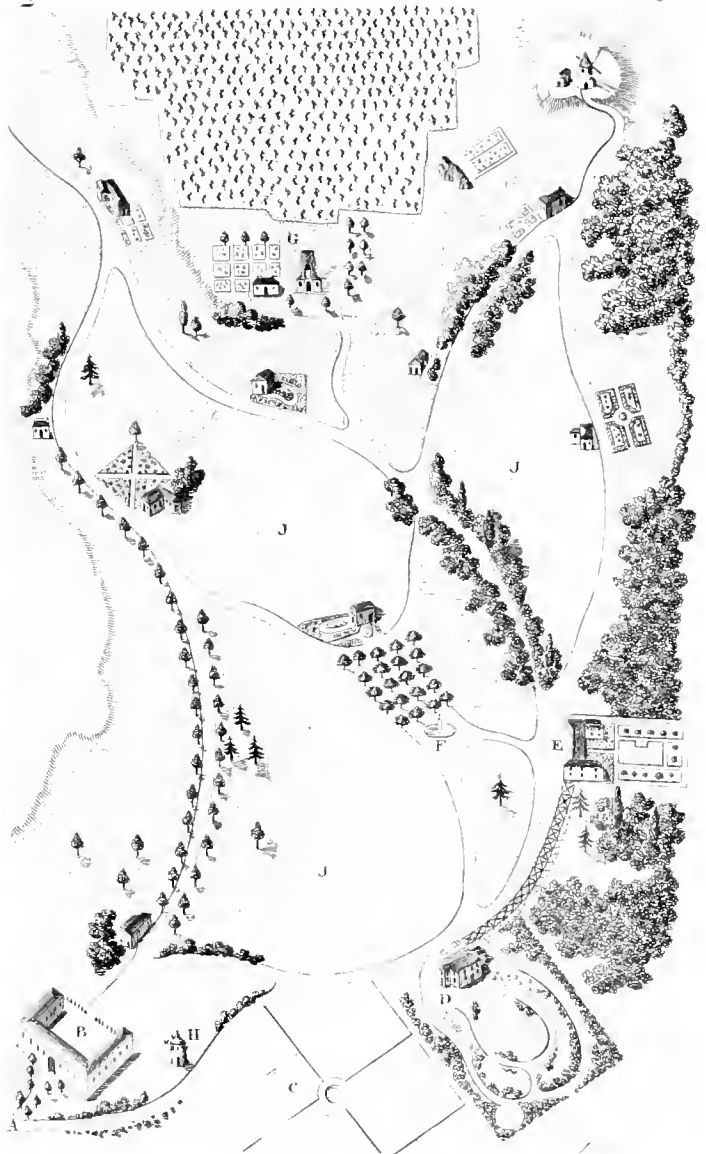






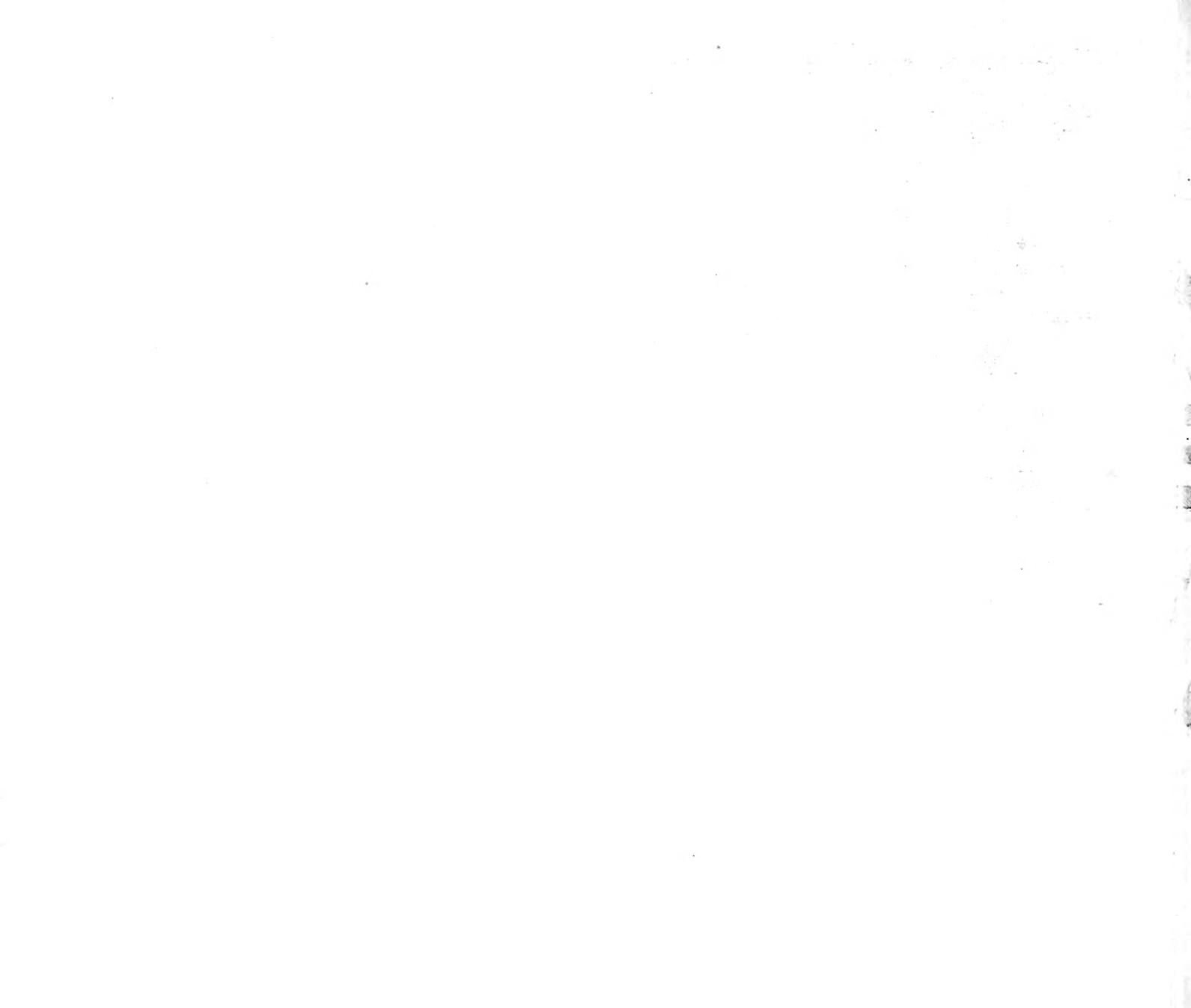
Audot inv

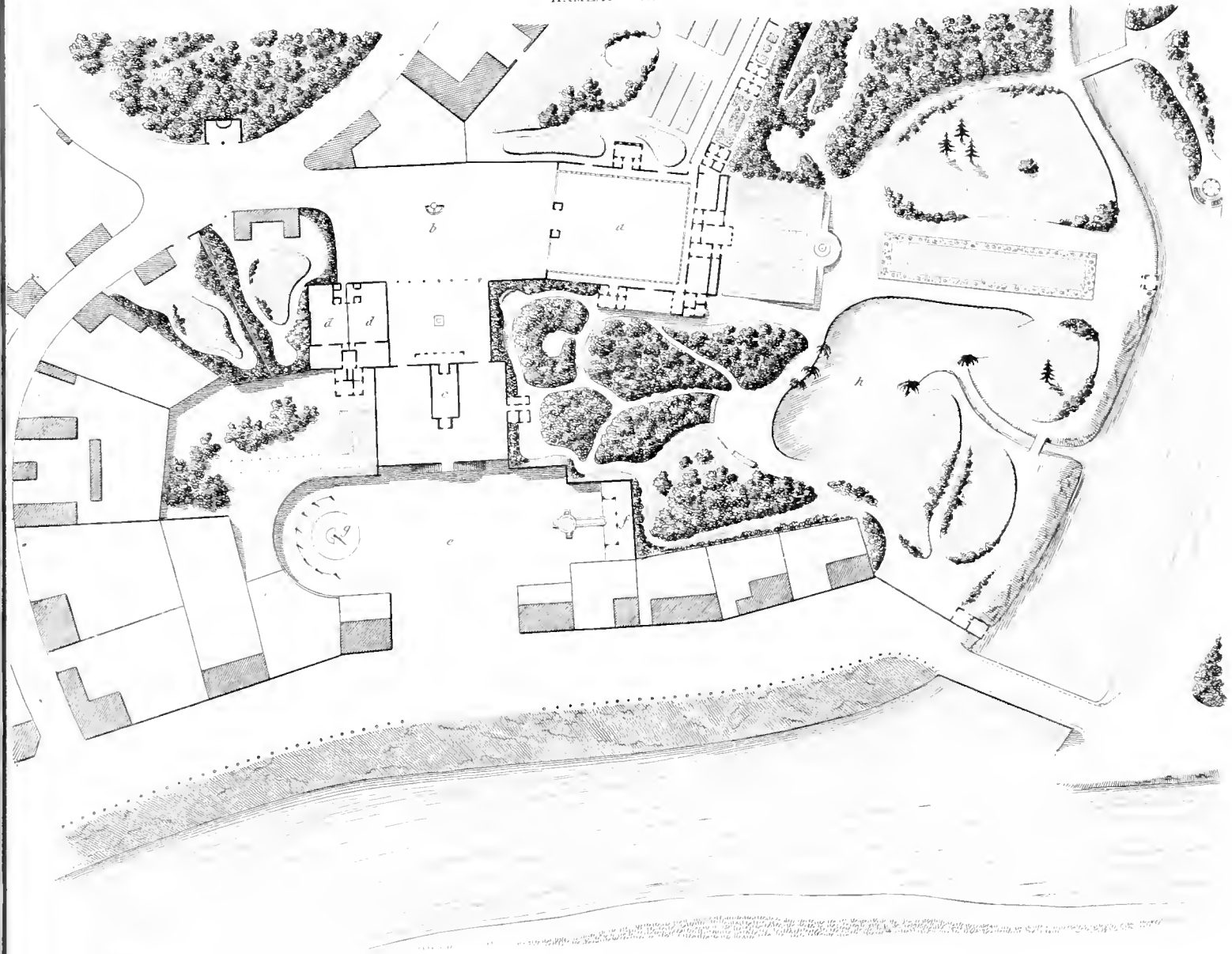
40 mètres



Audot inv

40 mètres

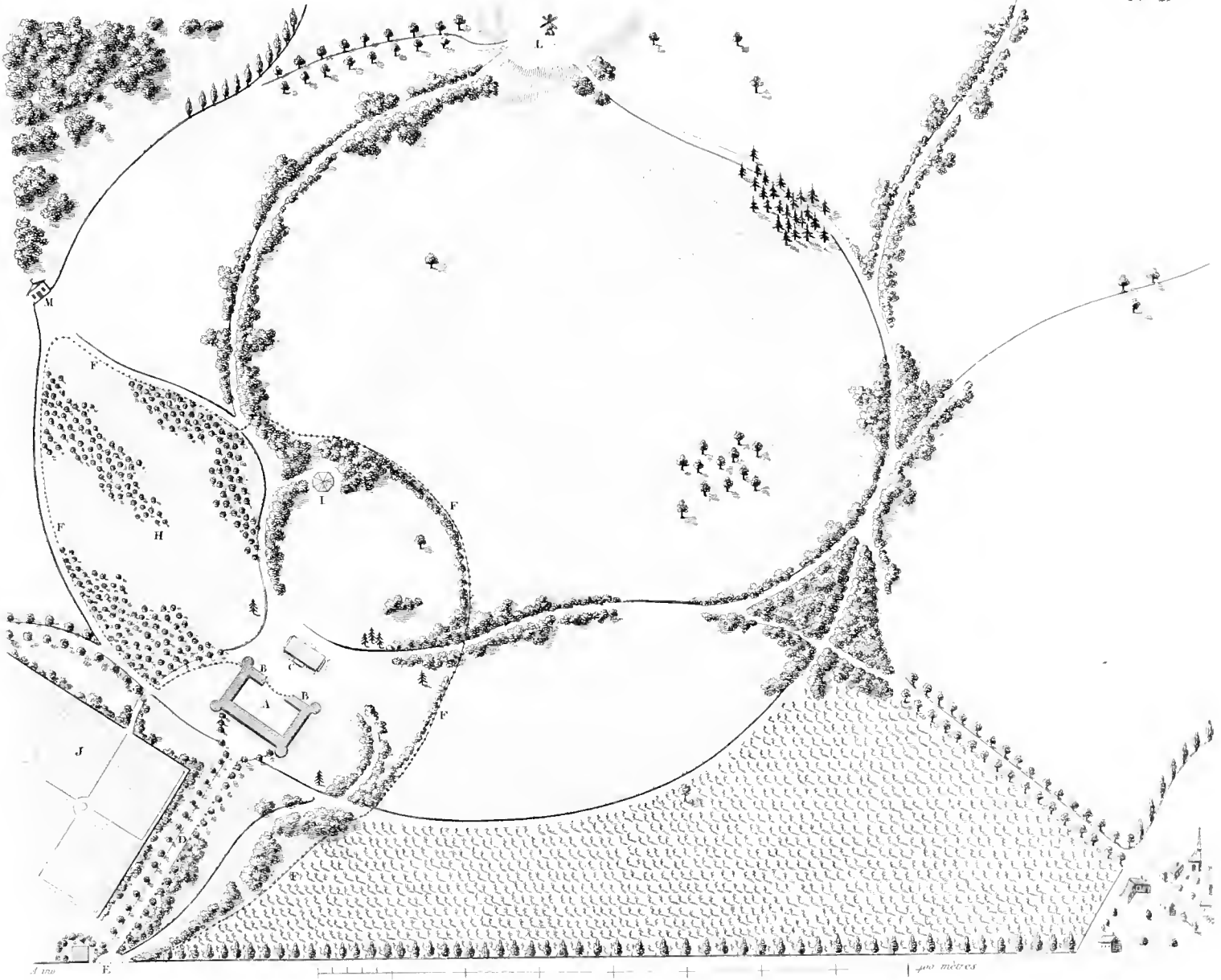




70 metres

1827

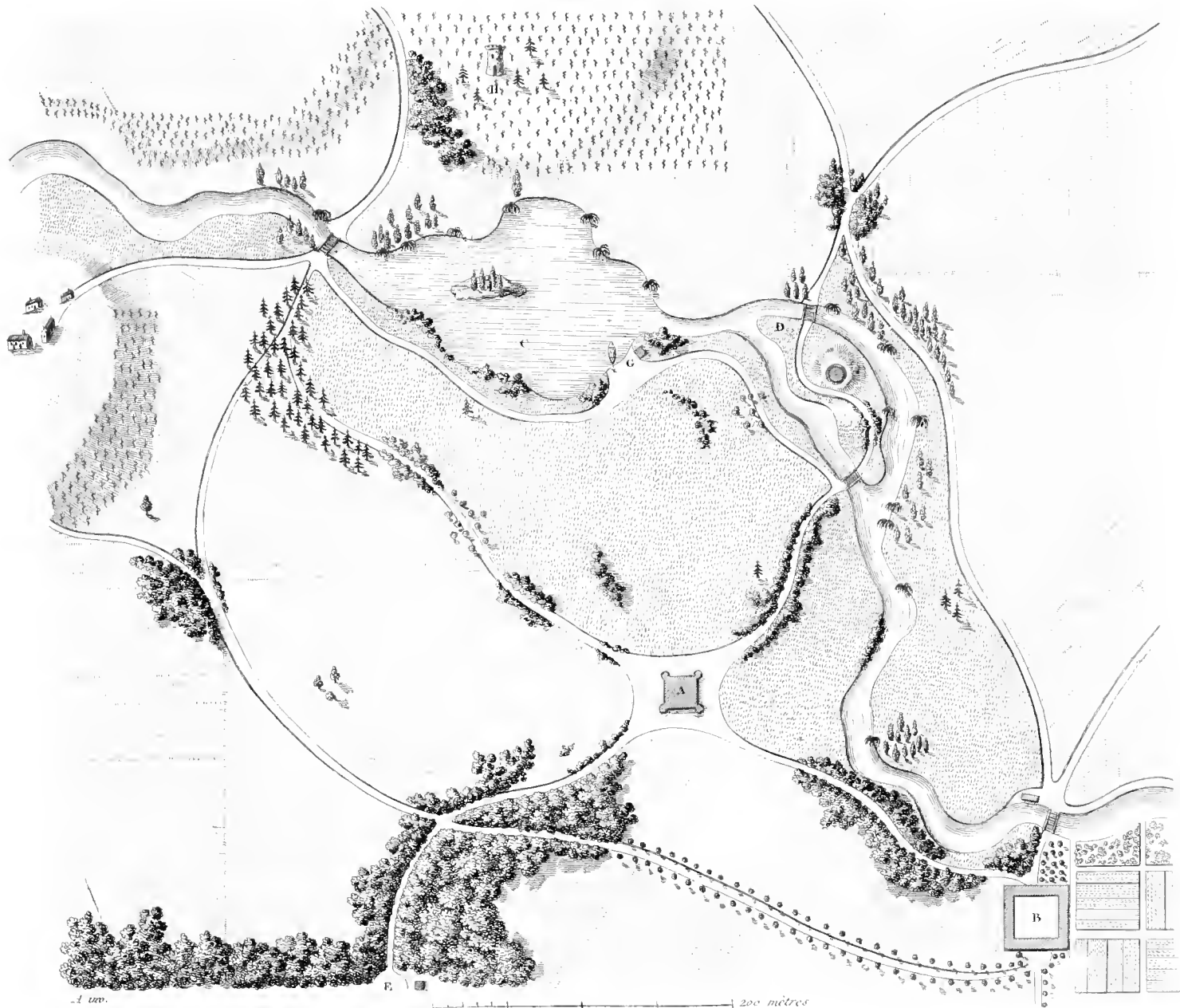




A 100

100 mètres



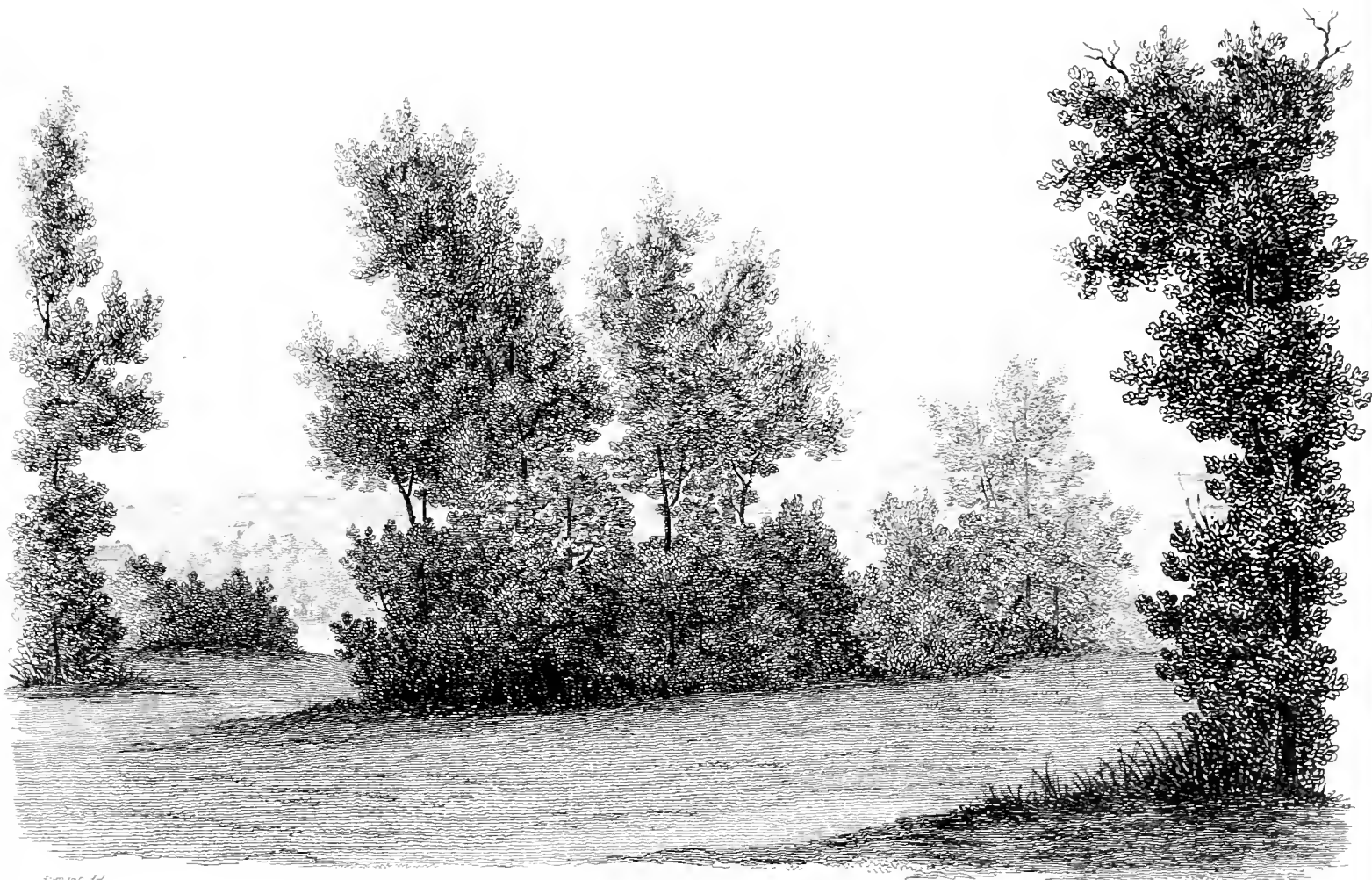


A. un.

P.

200 mètres



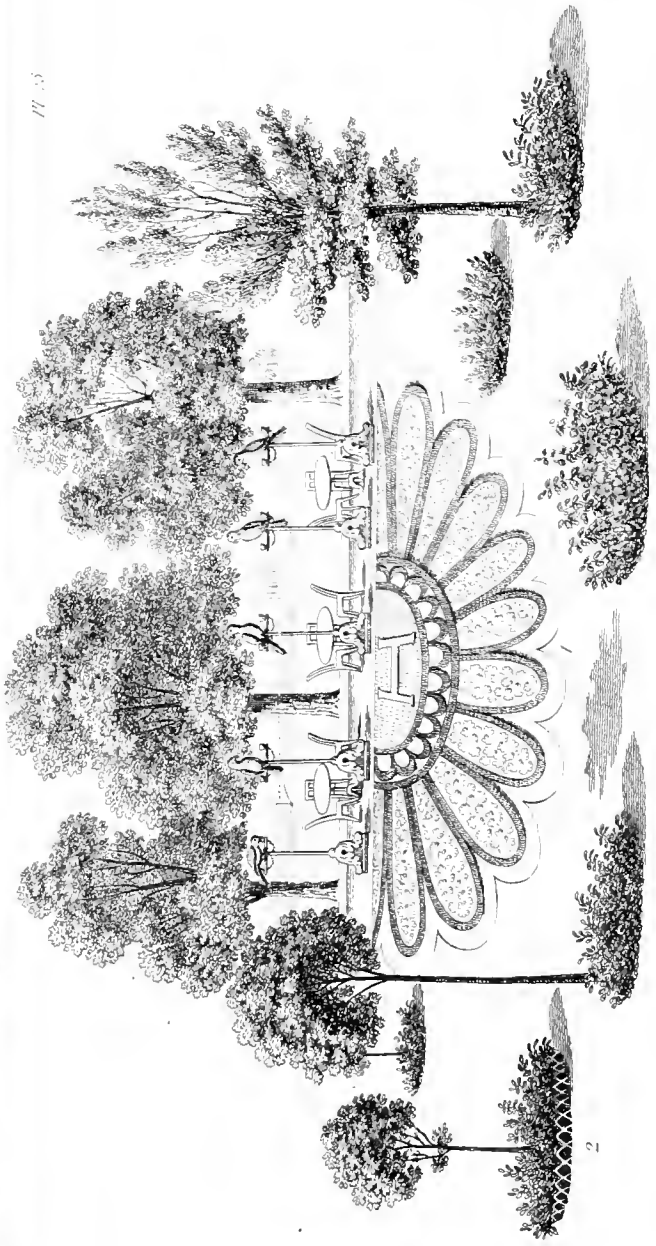


Baron de L.

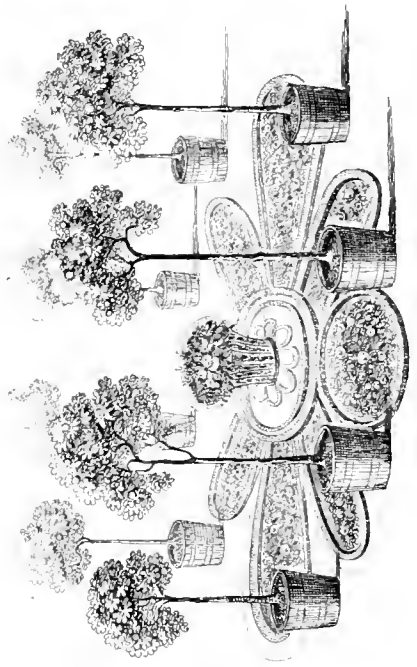
EXEMPLE DE PLANTATION, PRIS A FROMONT, CHEZ M SOULANGE BODIN.

Plancher 22

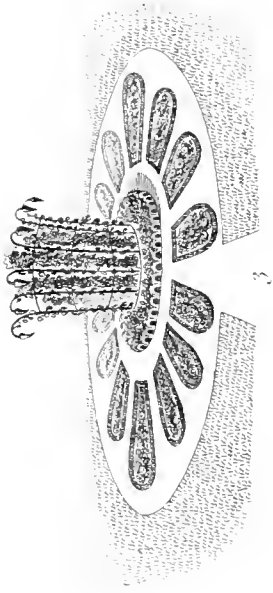




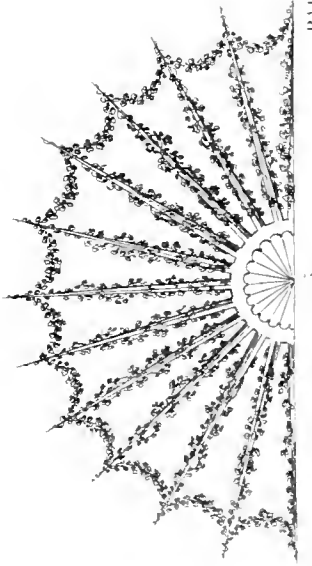
2



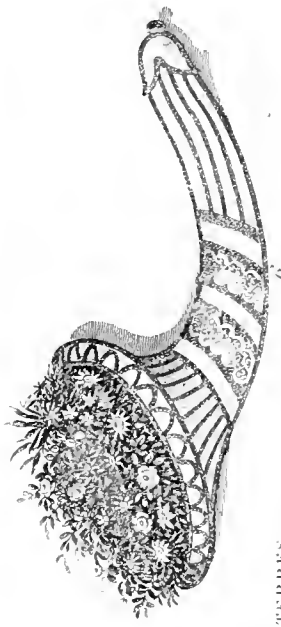
4



3

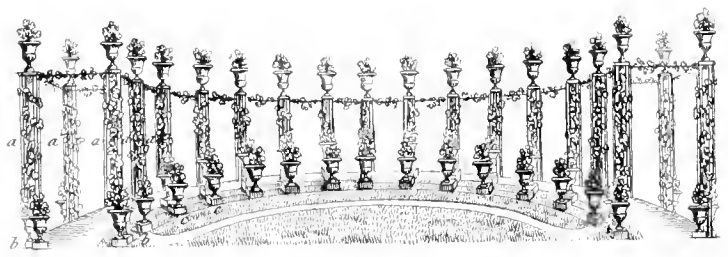


5

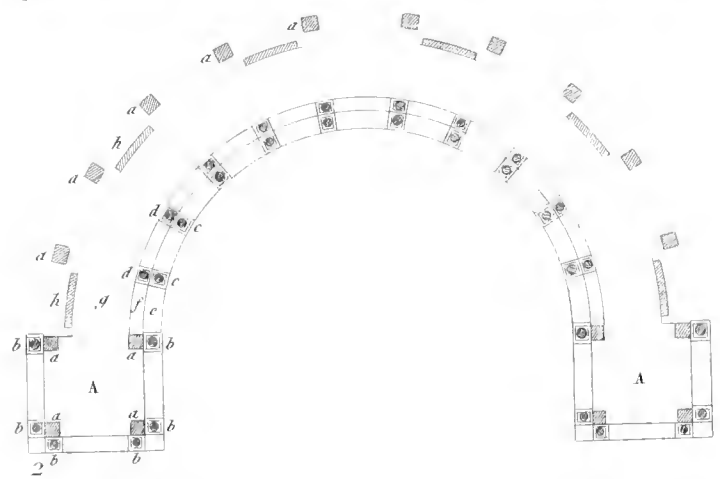


6

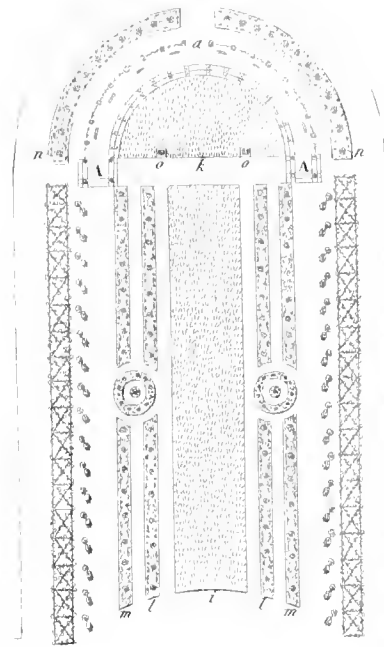
PARTERRES



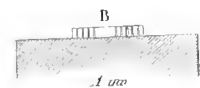
1



10 mètr

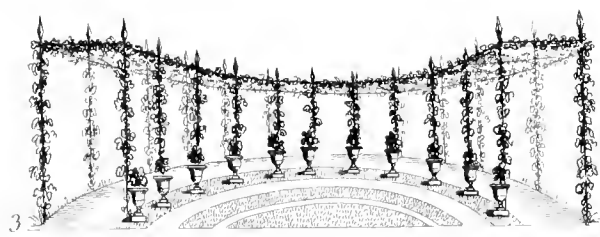


4



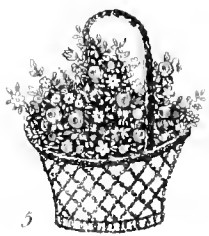
1 mètr

100 mètr



3

1 mètr



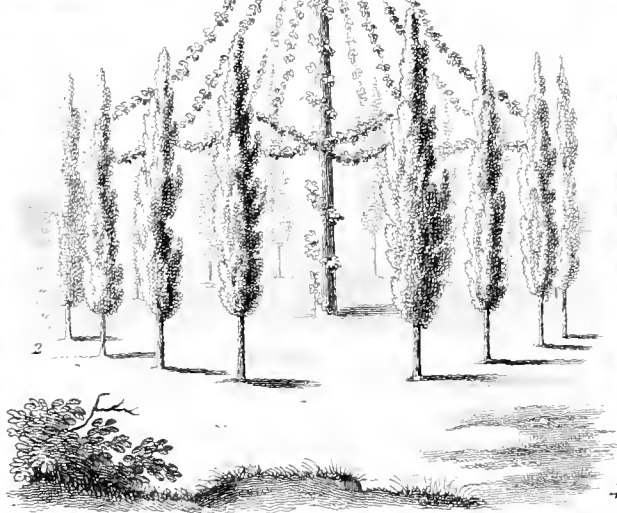
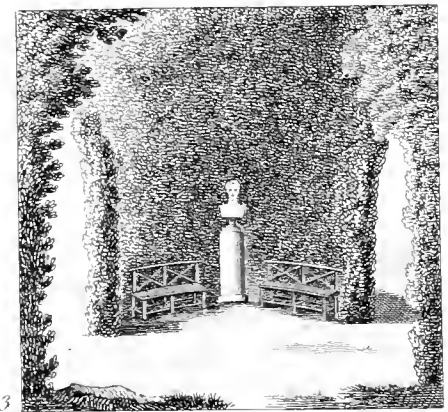
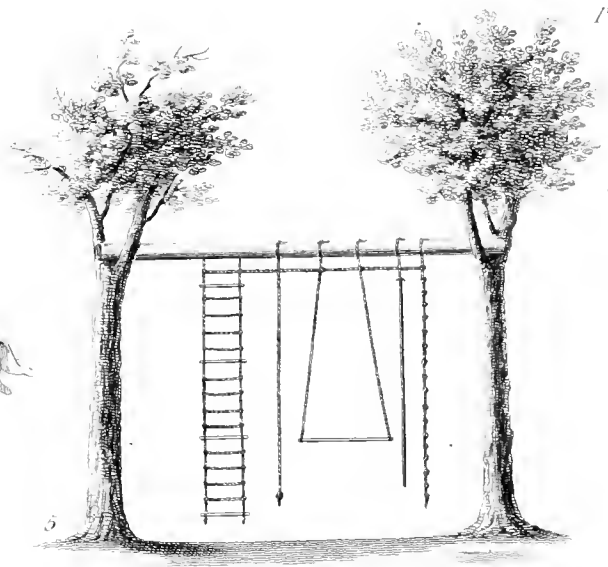
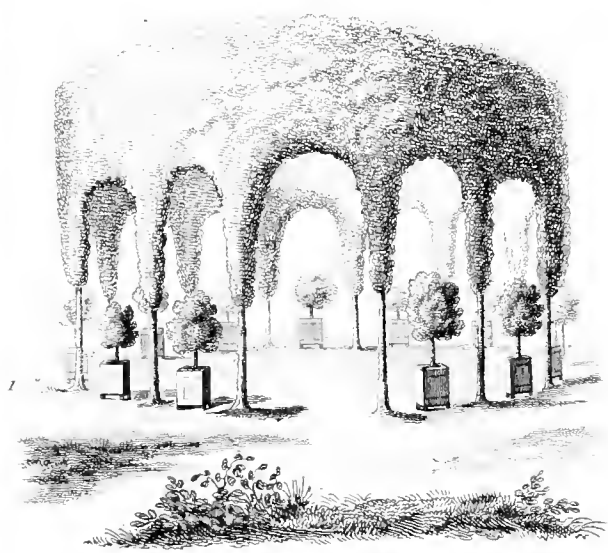
5



6

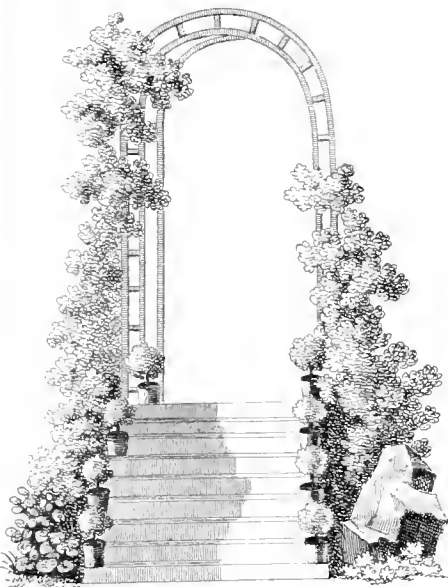
PARTERRES — EXEDRE — PERGOLES.



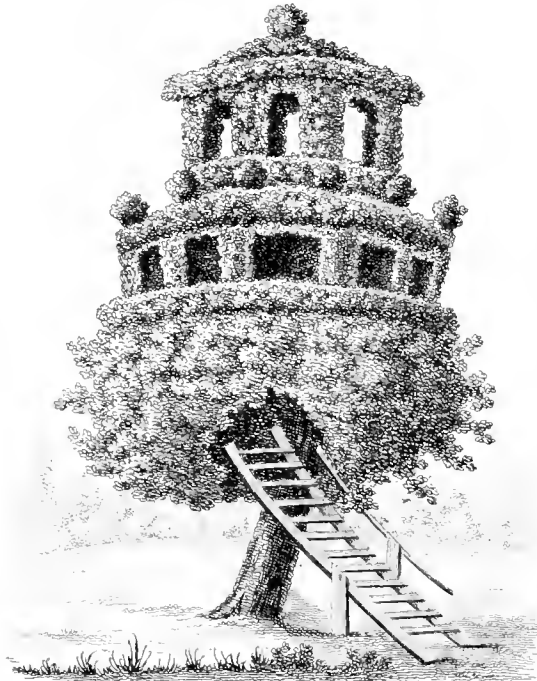


SALLES ET SALONS DE DANSE. PORTIQUE DE LA GYMNASTIQUE.

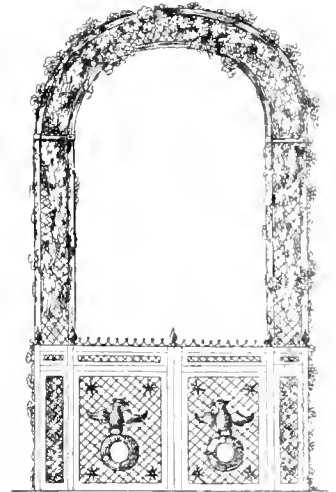




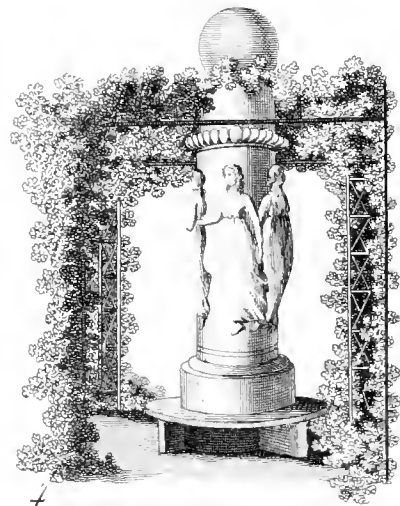
1



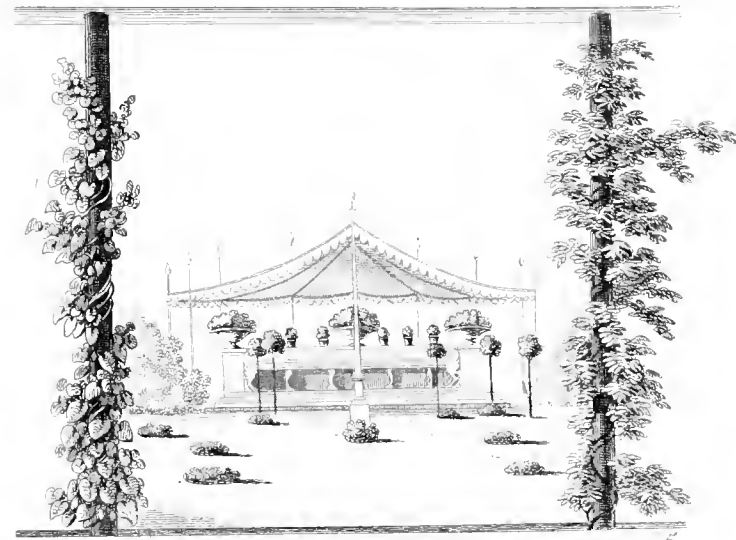
3



2

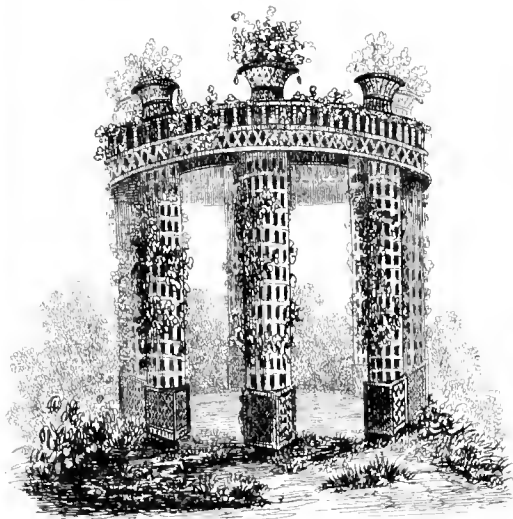


4

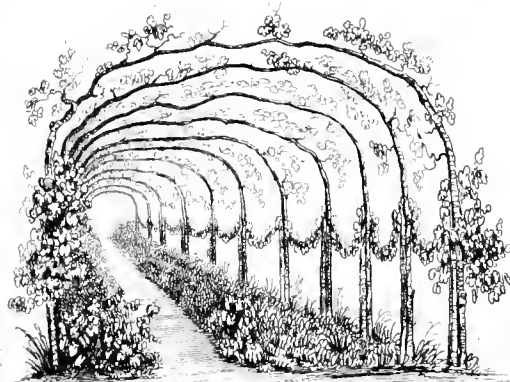


5





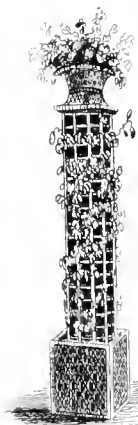
2



1



3



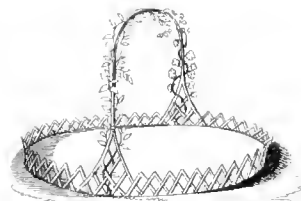
4



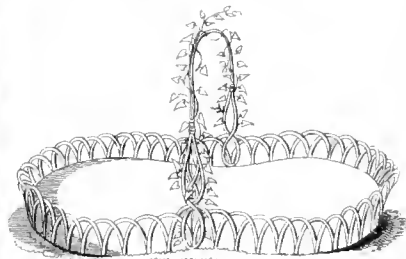
5



8



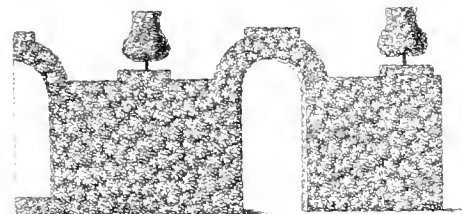
6



7

DÉCORATIONS - PARTERRES - SERRE.





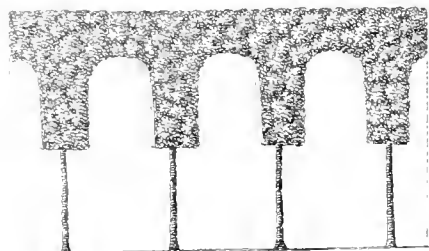
1



2



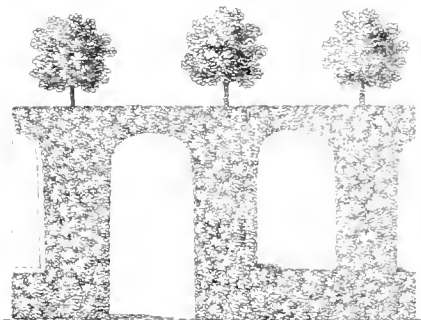
3



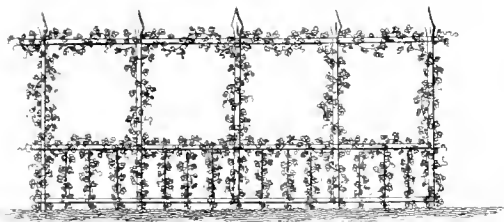
4



5



6



7

A. V. C.



8



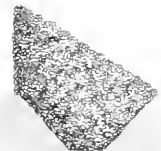
9



10



11



12



13



14



15



16

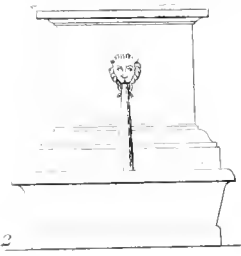
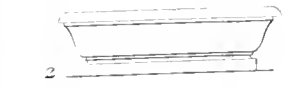
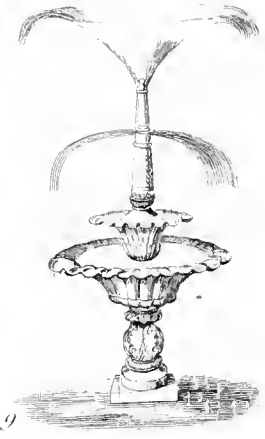
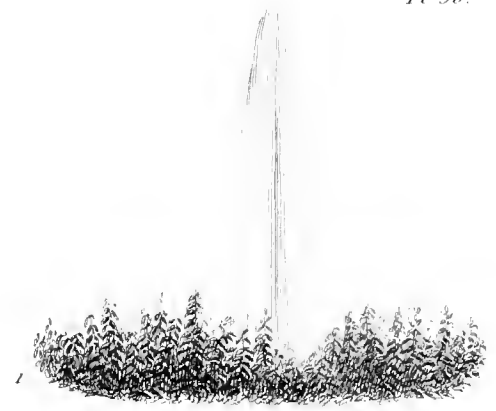
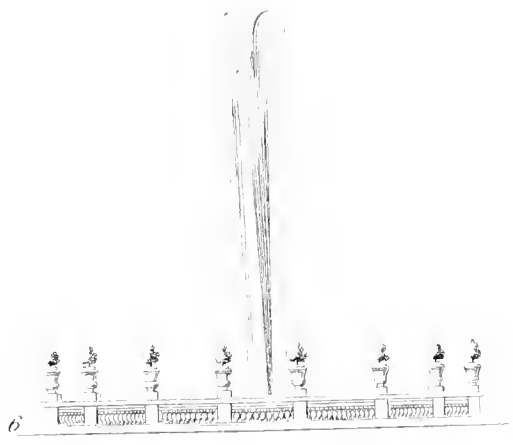
PALISSADES ARCADES PERGOLE.





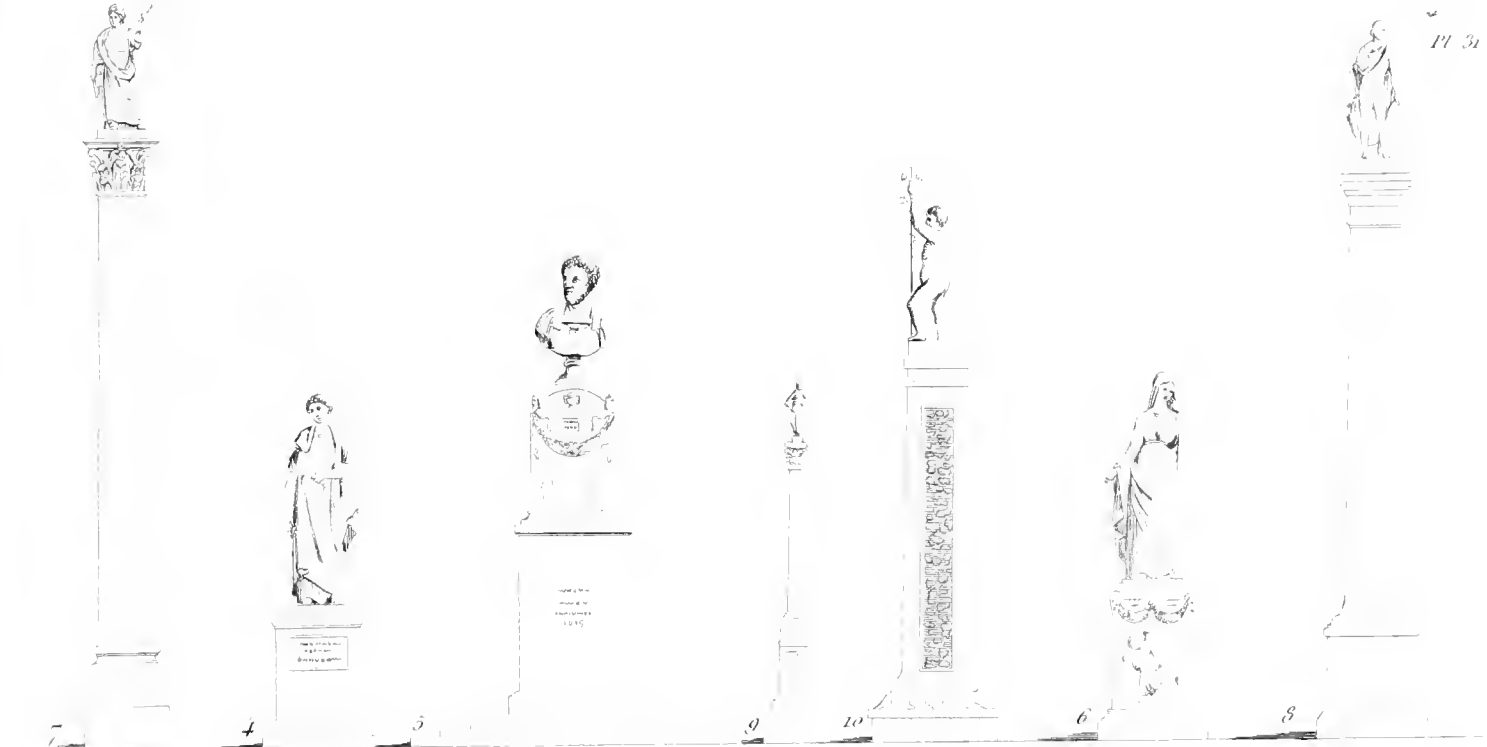
Exemple d'un jardin avec d'esp. taillés de diverses formes existant à Givins-hall, Westmorland. Angleterre





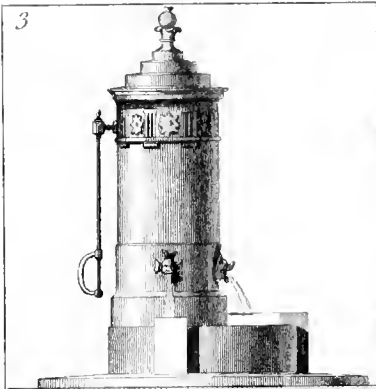
FONTAINES, BASSINS, EFFETS D'EAU.





FONTAINES, PIÉDESTAUX, COLONNES ISOLÉES



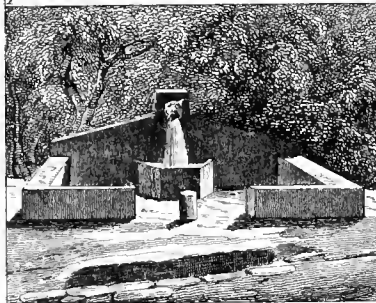


Pompe.

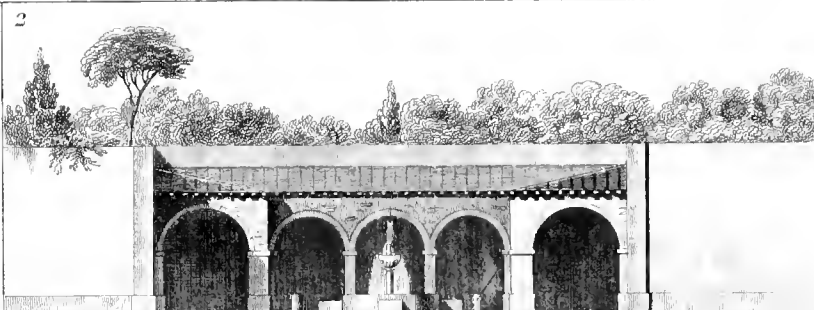
Plan.



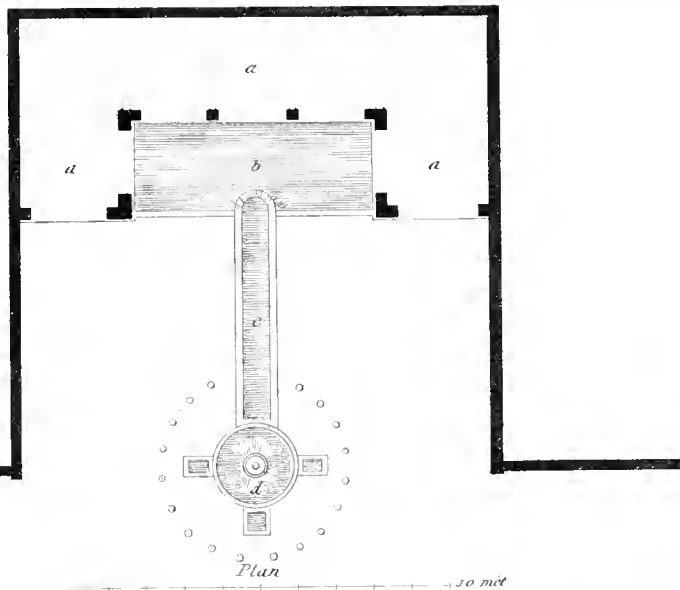
2 met.



Fontaine sur un chemin.



Fontaine et Lavoir.



Plan

30 met



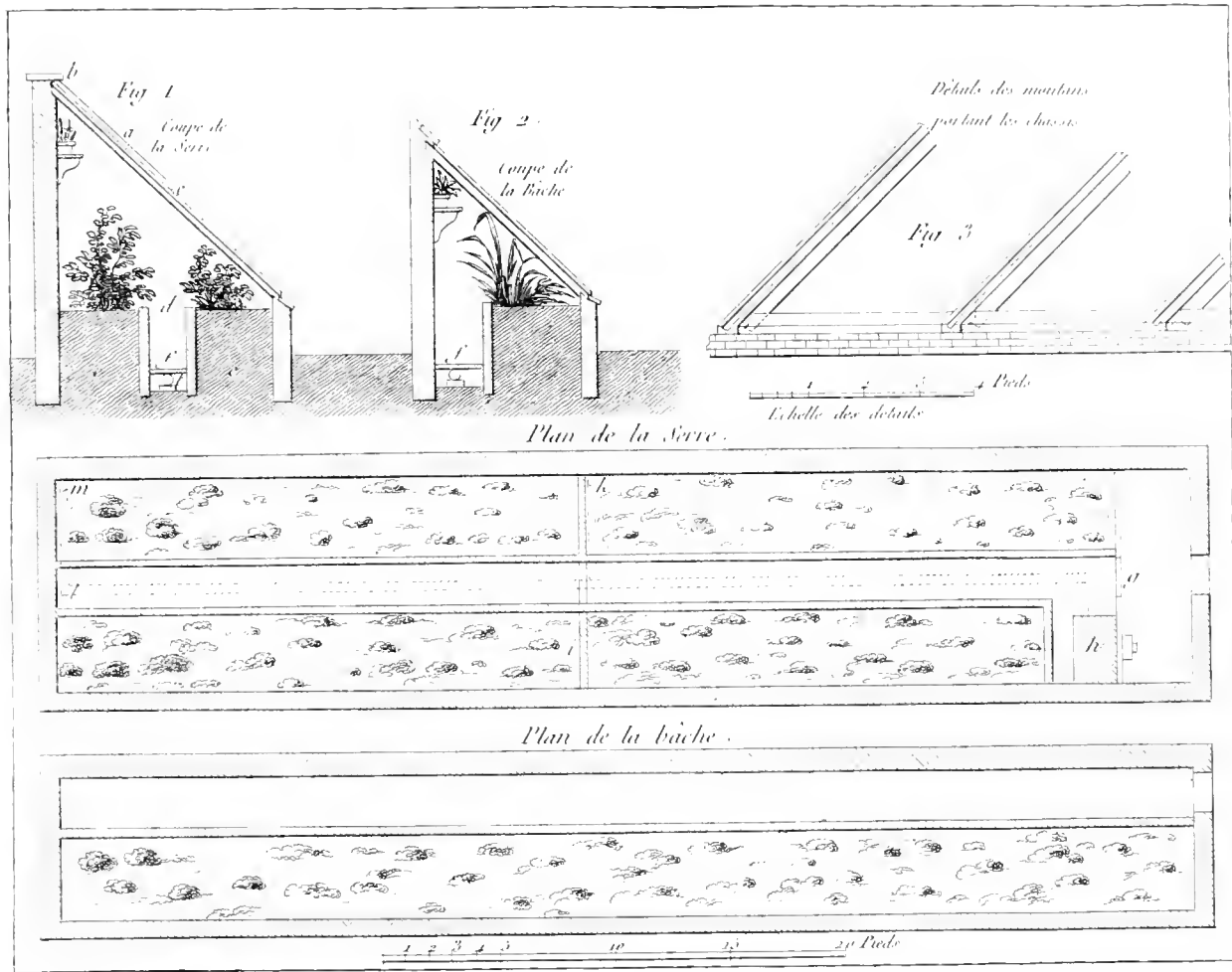
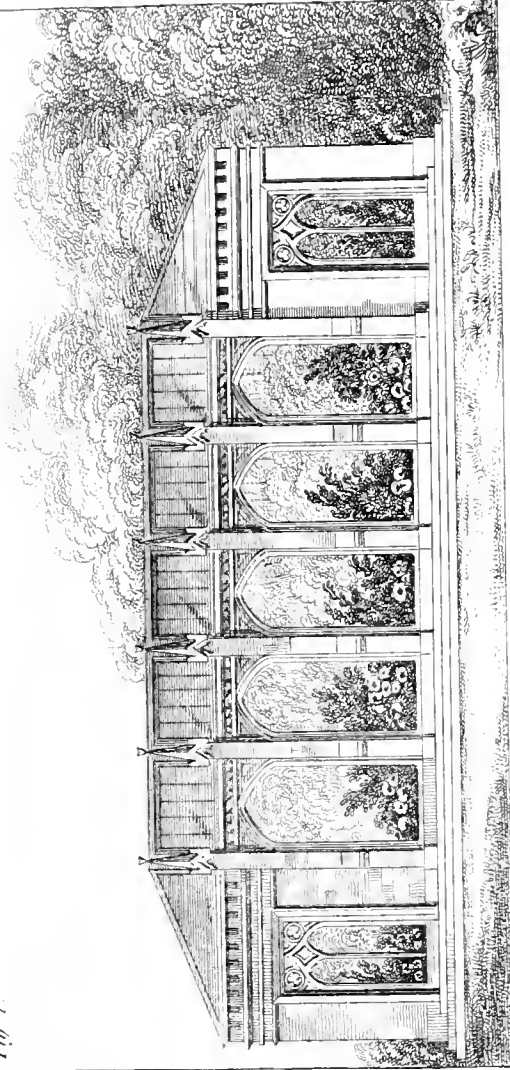


Fig. 1.



B Fenêtre orlée.

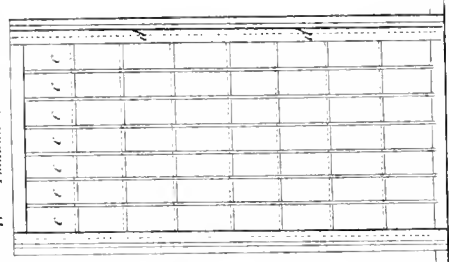
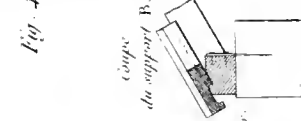


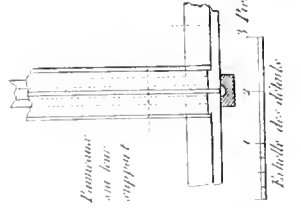
Fig. 4.



Amorce

ou leur

appui

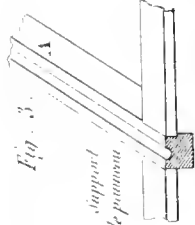


Echelle des abais.

Fig. 3.

Appui

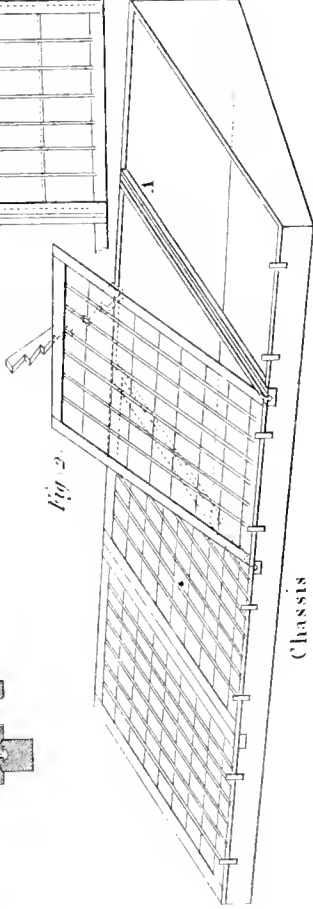
de panneau.



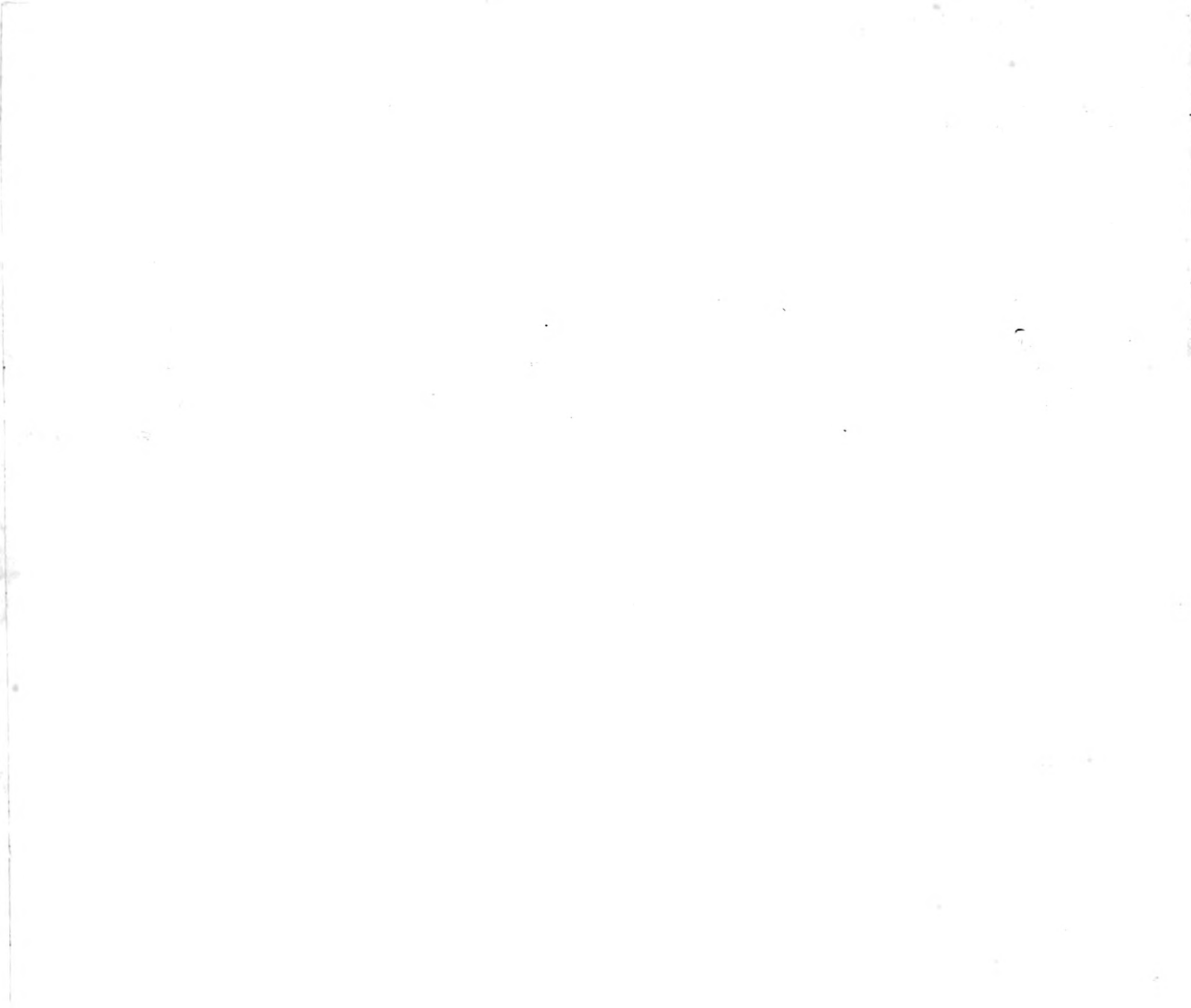
Autre appui B.

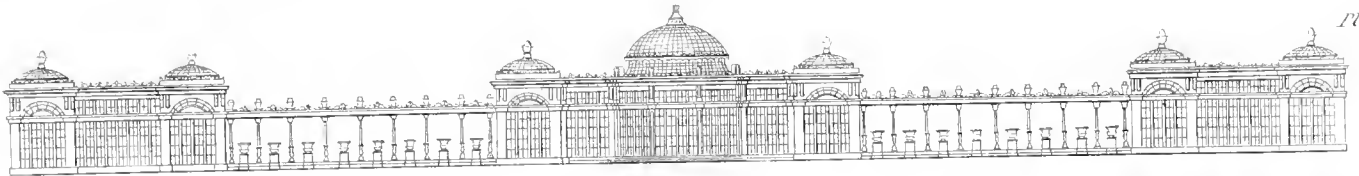


Fig. 2.

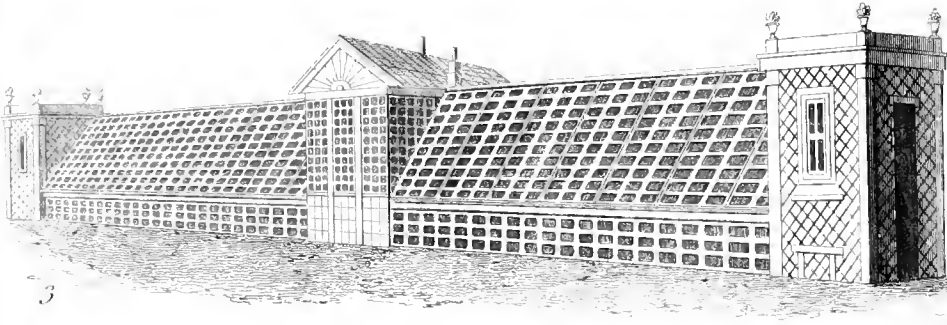


Chassis

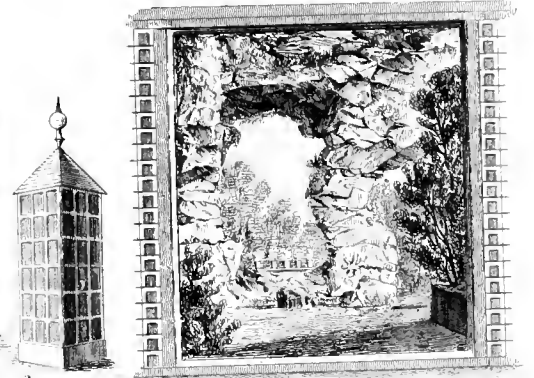




1

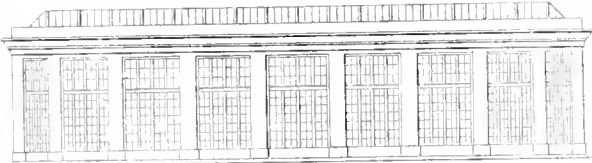


3

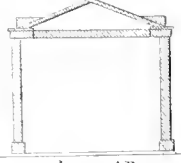


6

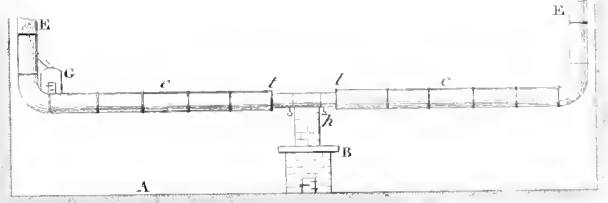
4



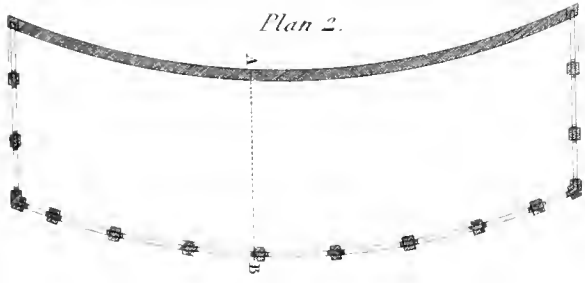
2



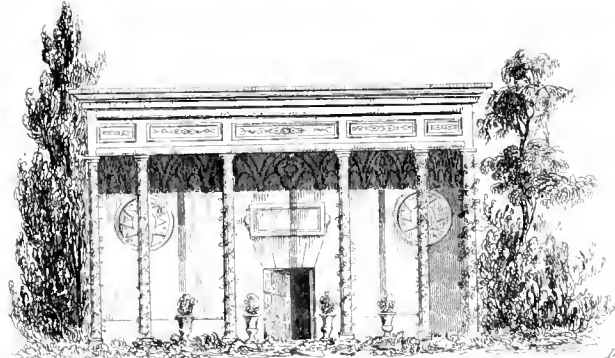
Coupe AB.



7

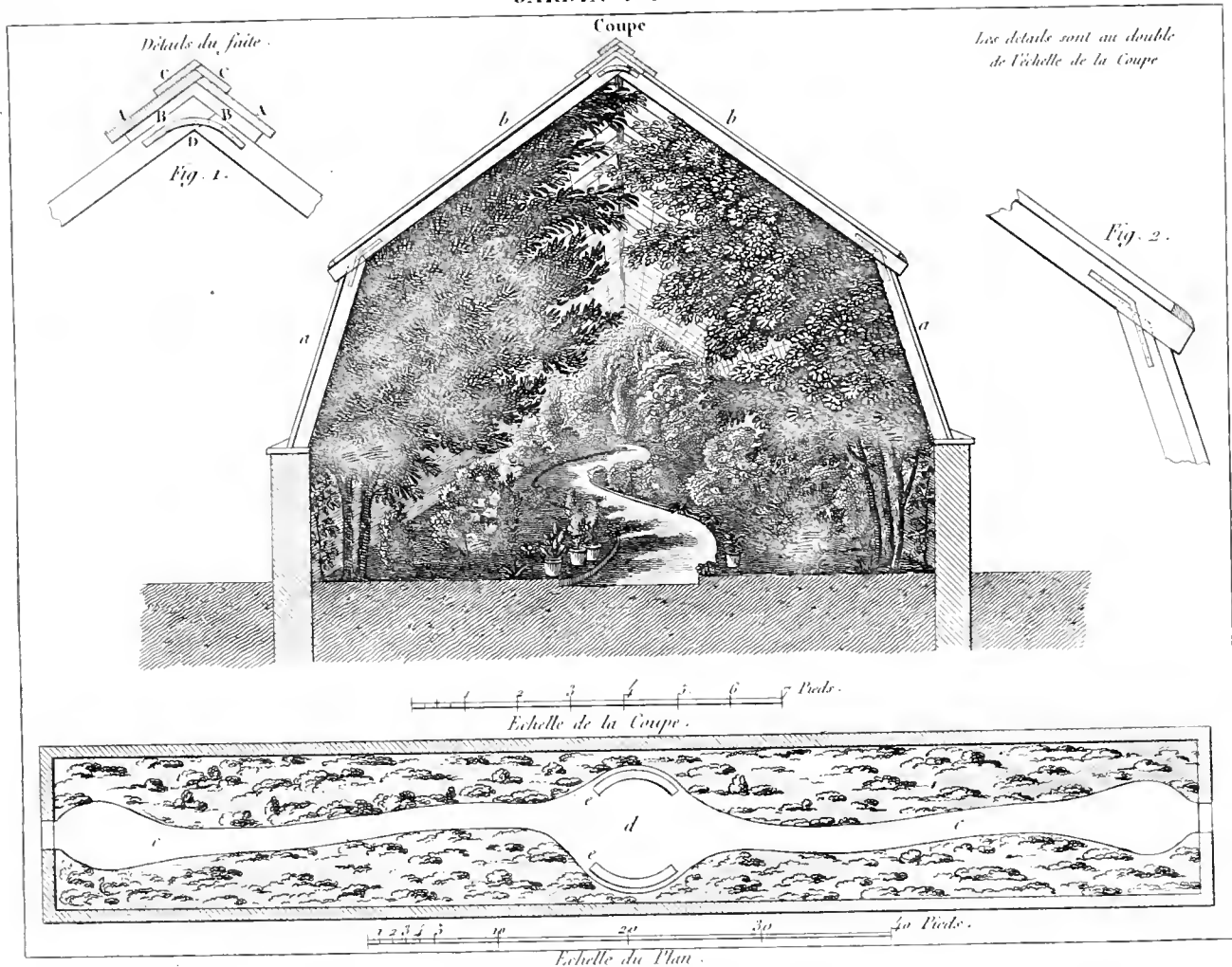


Plan 2.

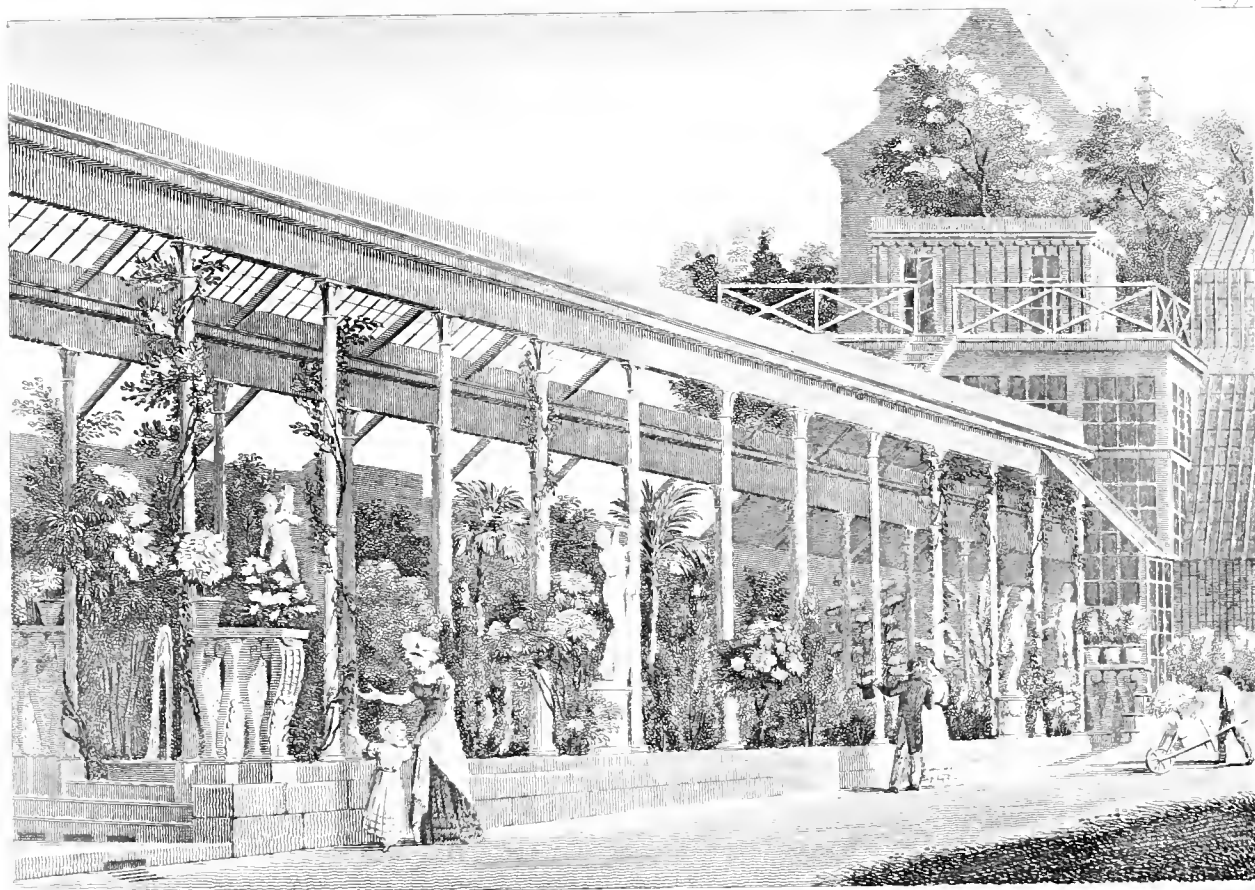


Dur. 10









SERRE ORNÉE

du Jardin de M^l Bourville.



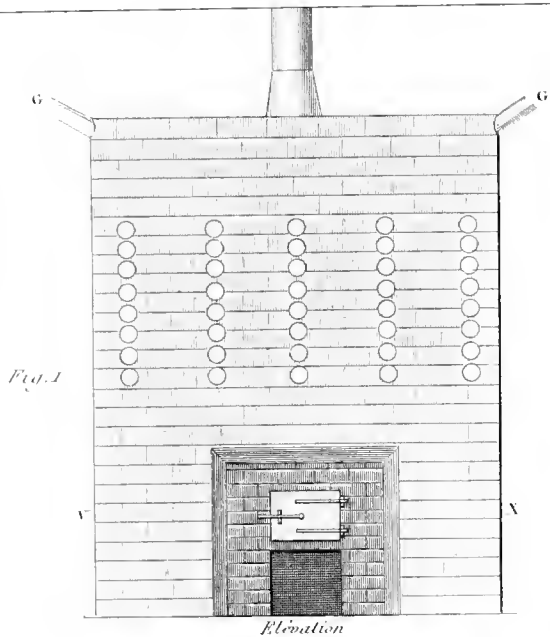


Fig. 1

Elevation

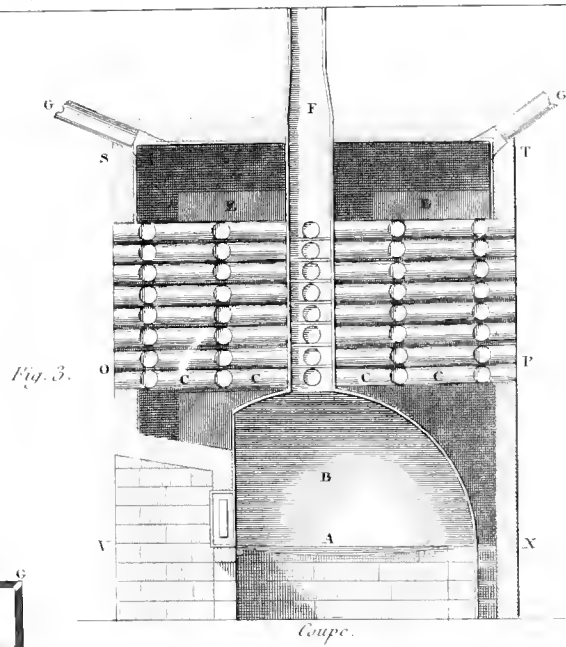


Fig. 3.

Coupe.

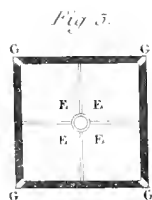


Fig. 5.

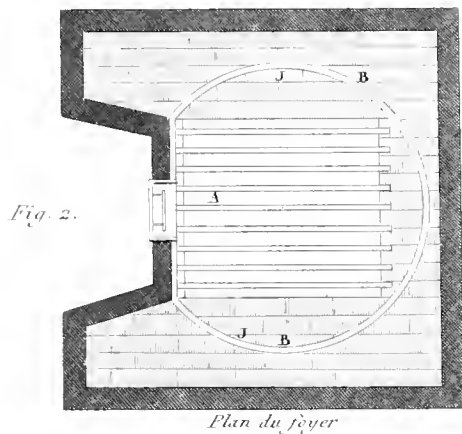


Fig. 2.

Plan du foyer

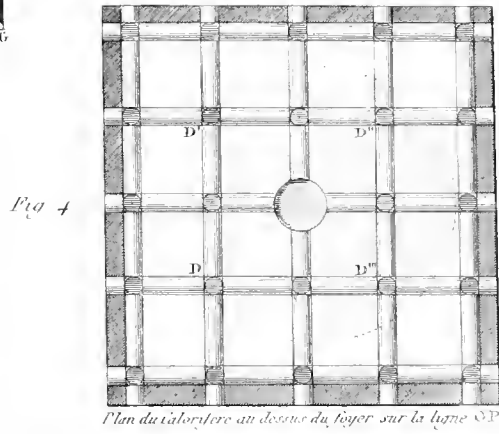


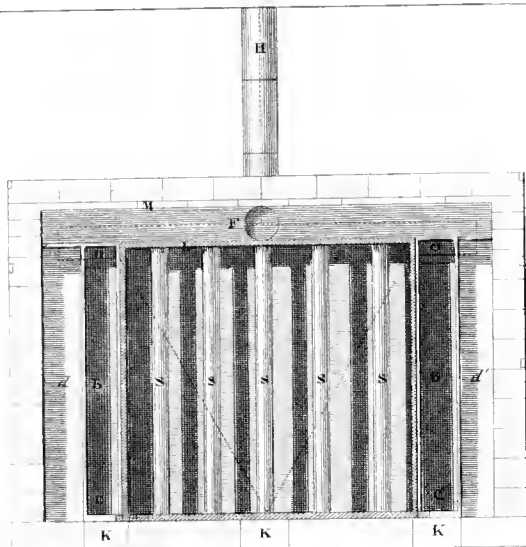
Fig. 4

Plan du calorifere au dessous du foyer sur la ligne XY

— 1 metre

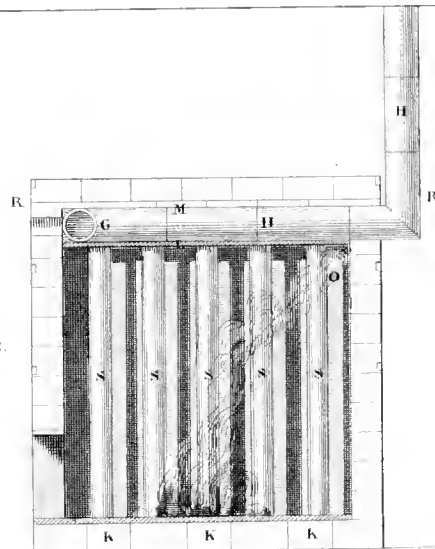


Fig. 3.



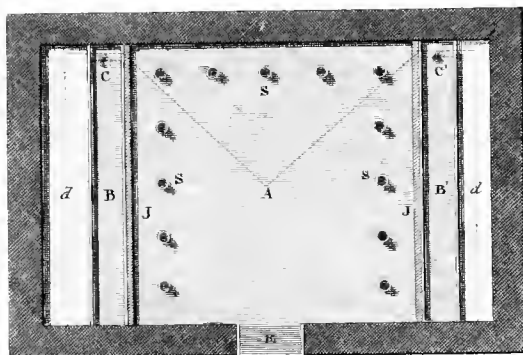
Coupe sur la largeur.

Fig 4.



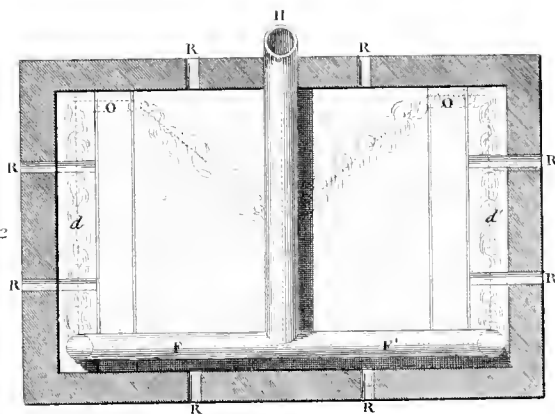
Coupe sur la profondeur.

Fig 1



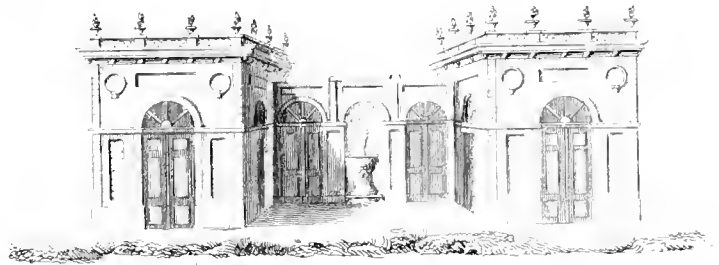
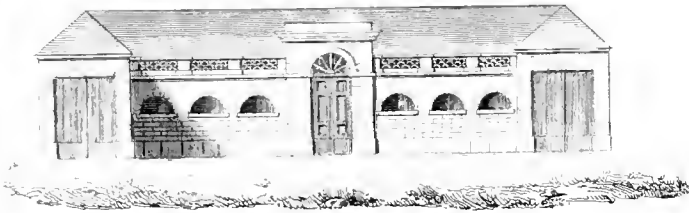
Plan au niveau du foyer.

Fig 2



Plan du calorifere sur la ligne RR.

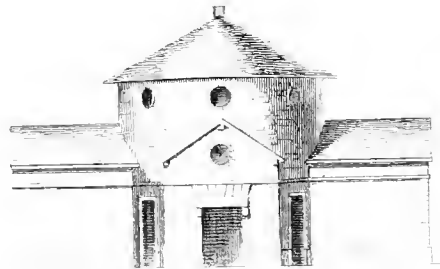
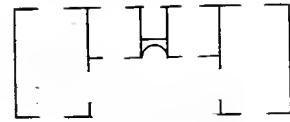




4

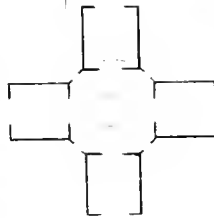


5

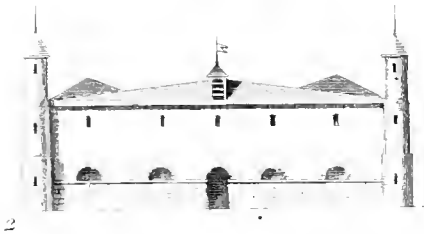
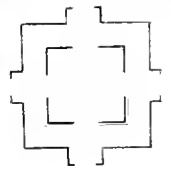


7

9

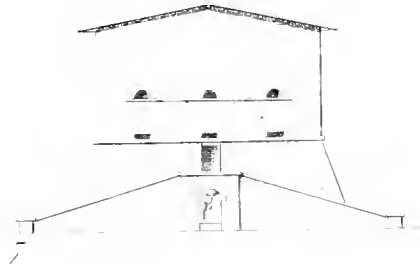


10



2

3

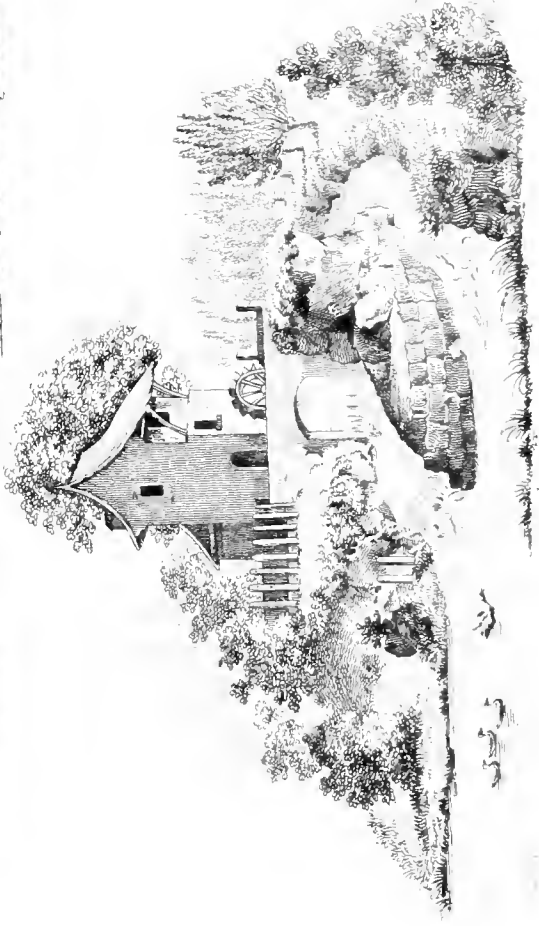
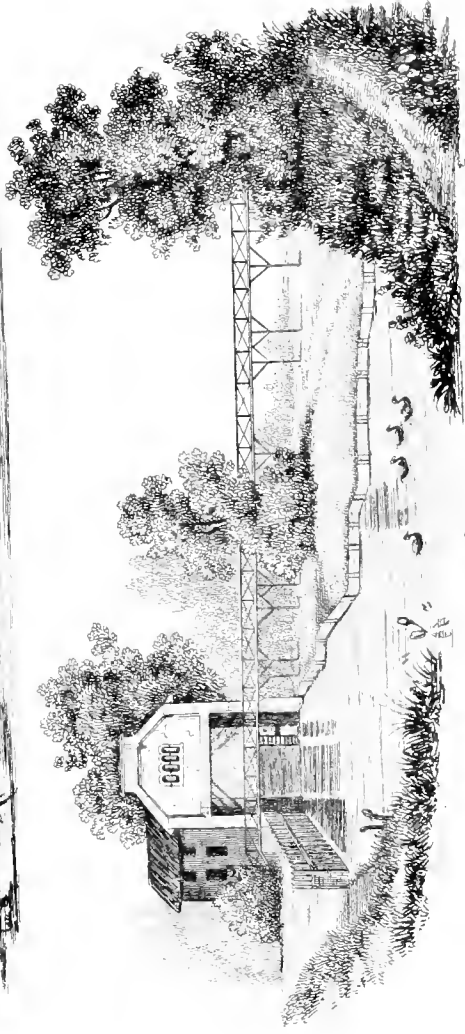
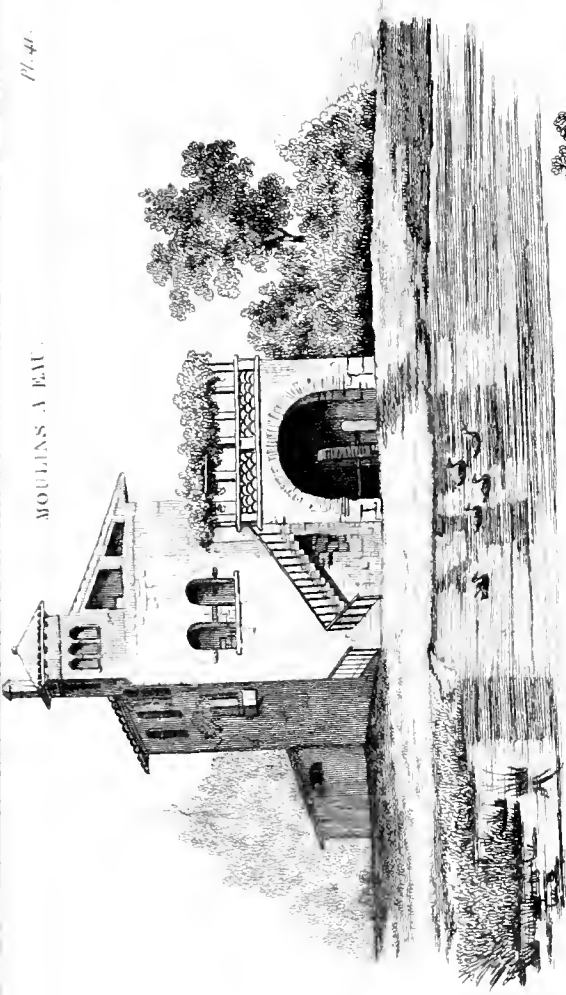


6

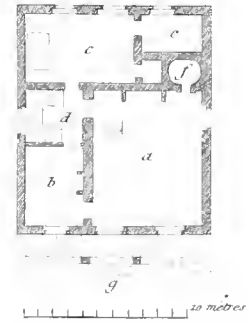
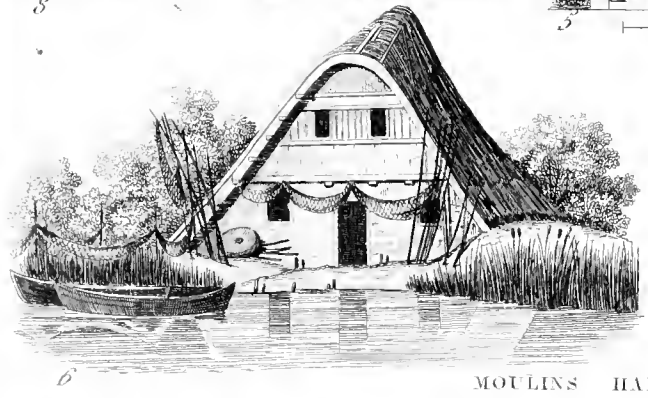
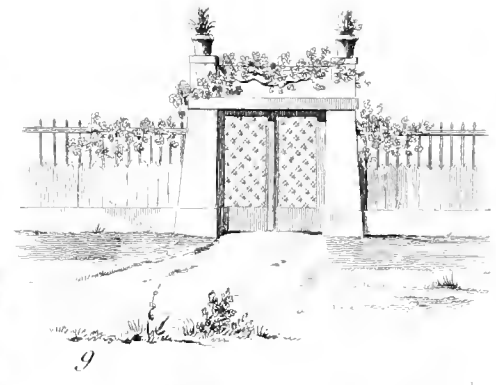
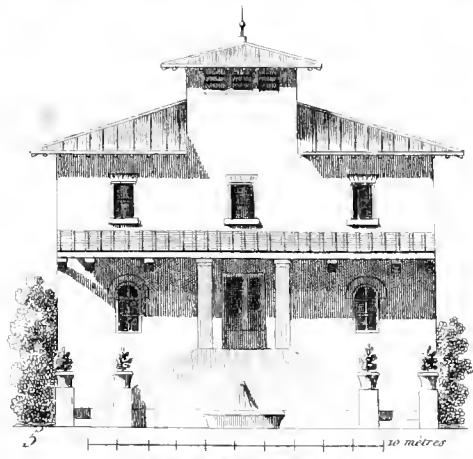
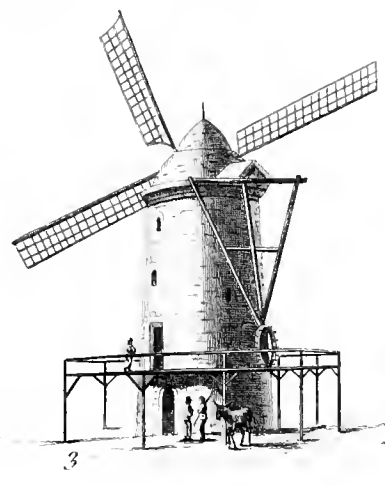
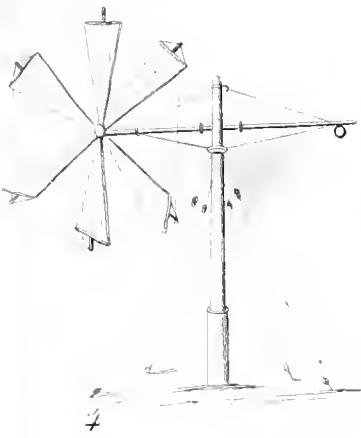
7

8



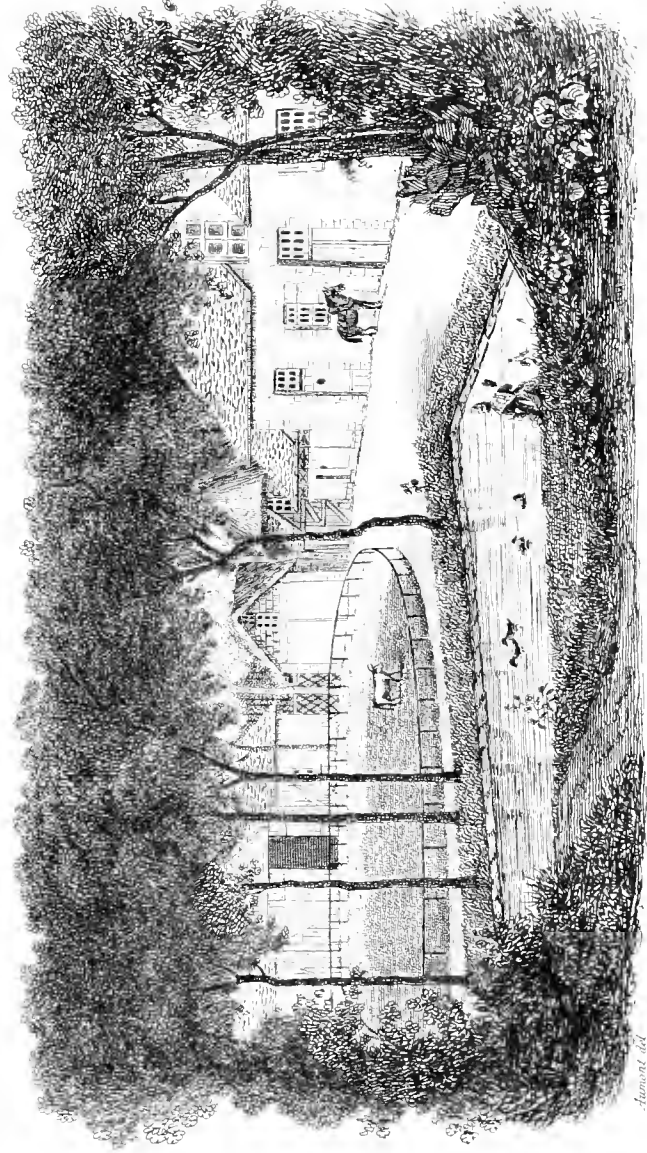
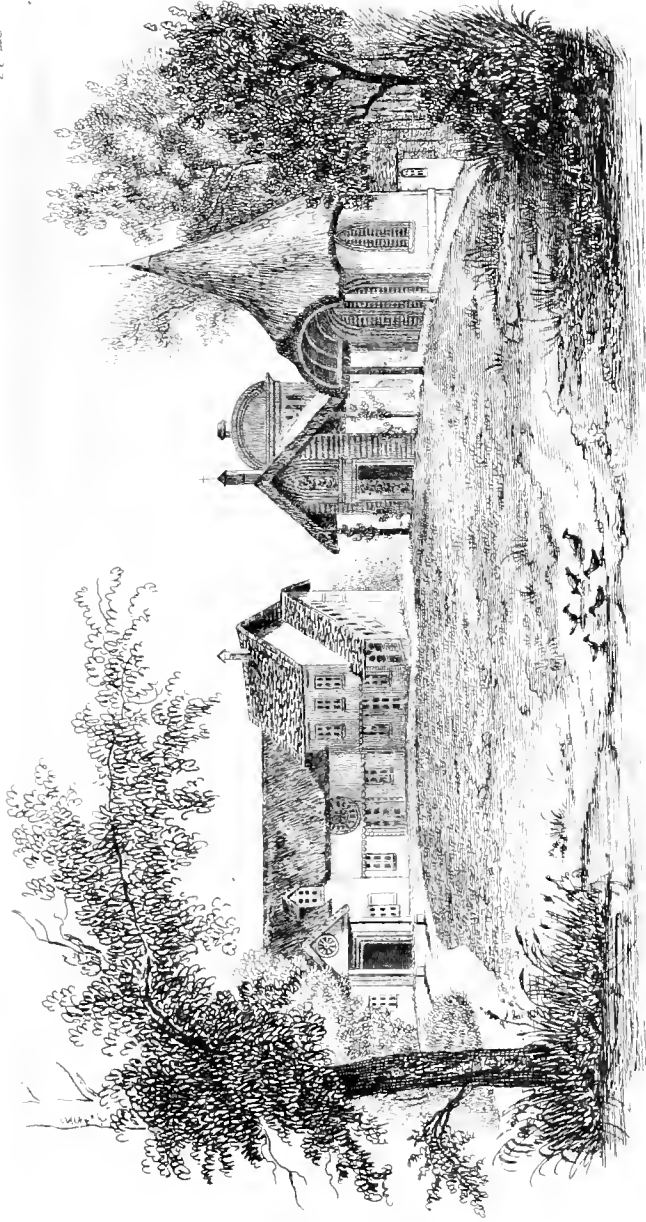






MOULINS HABITATIONS RUSTIQUES. ENTRÉES.



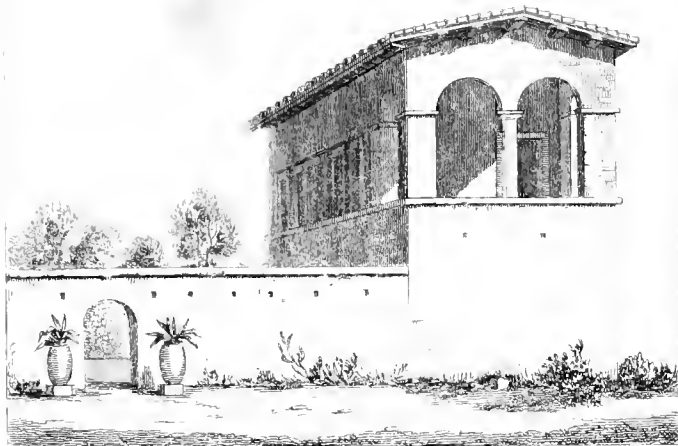


Amant del.

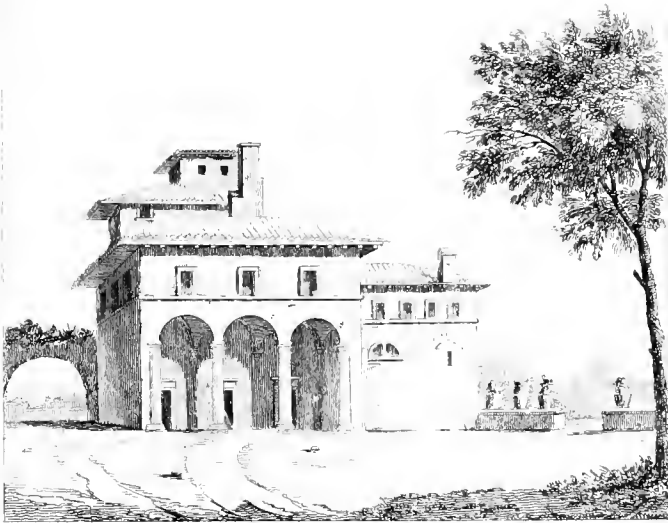
LA FERME DANS LE PARC DE MADAME DELESLE



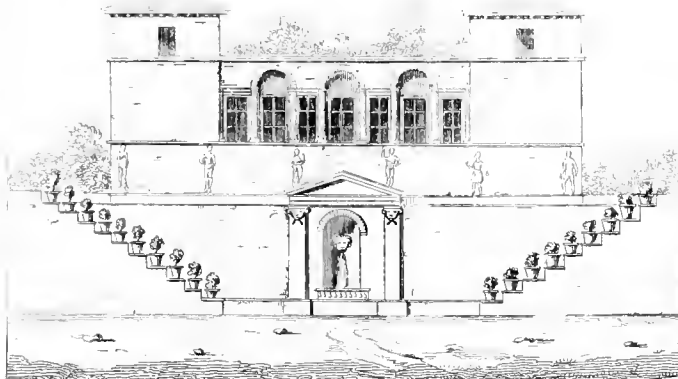
3



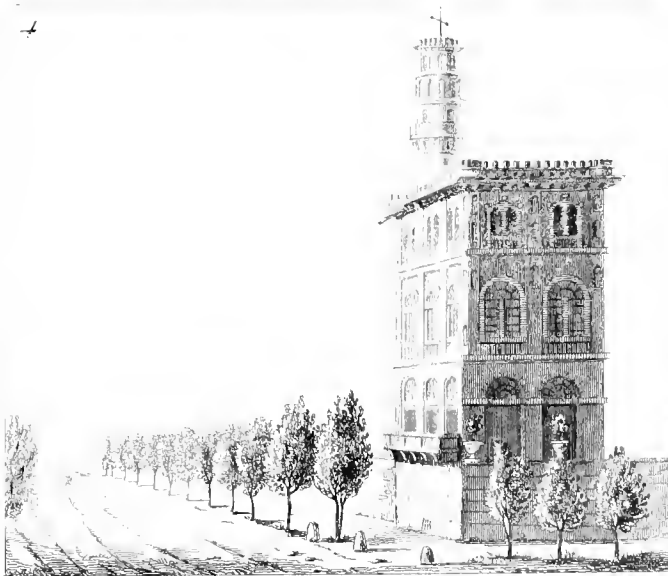
1



2

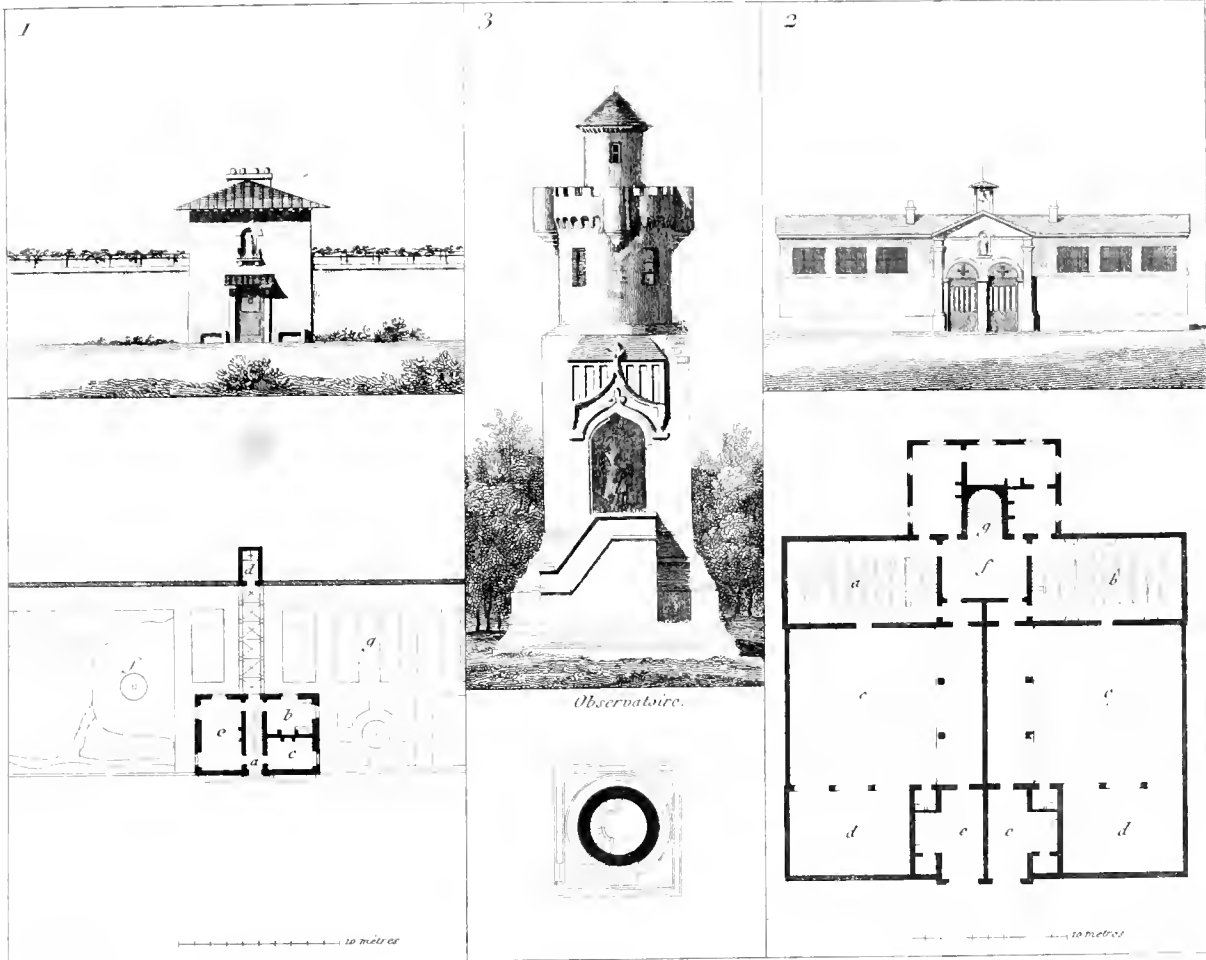


4



Barau

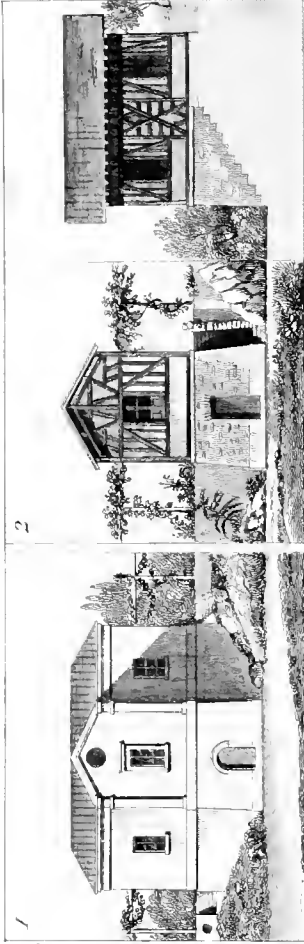






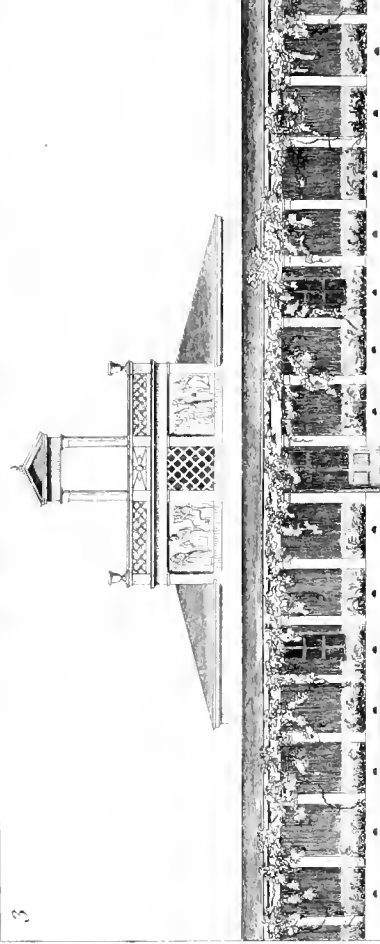






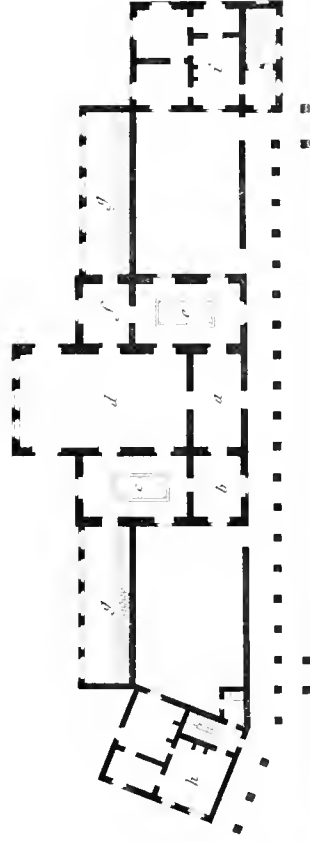
Piccola maison.

Chaumière.



Pavillon.

4



Turchese imp.

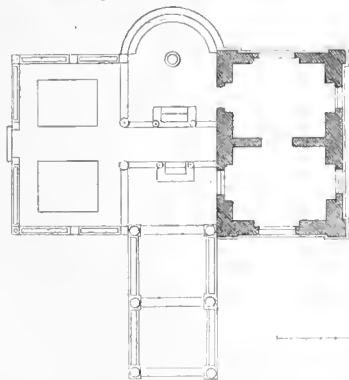
Pavone sc.



Z



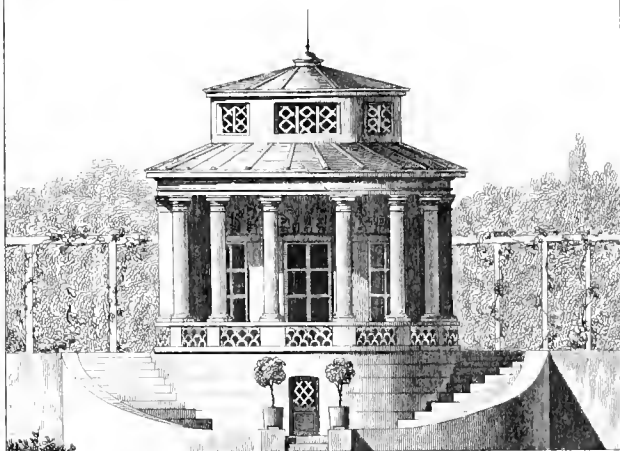
Pergole et Pavillon.



10 mètr.

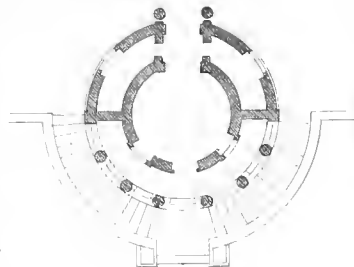
Cassini 1790

2



Pavillon

Rez-de-chaussée.



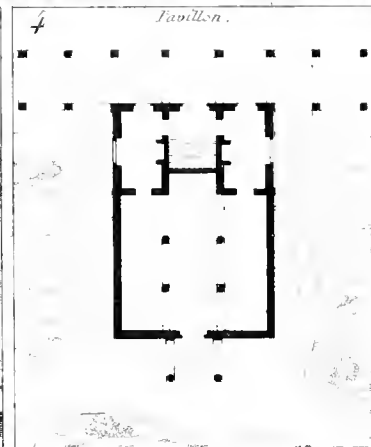
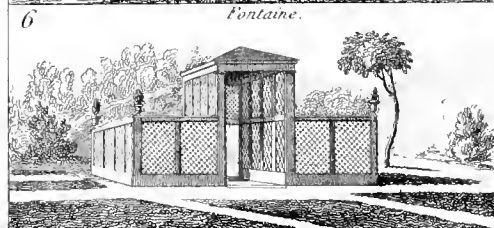
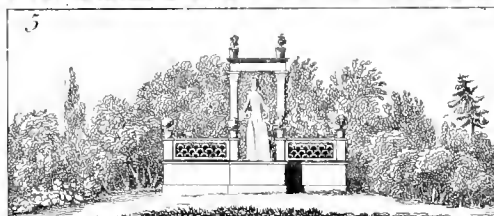
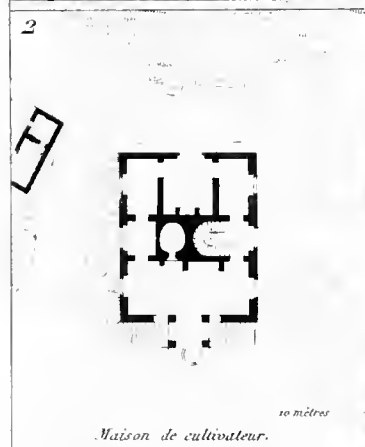
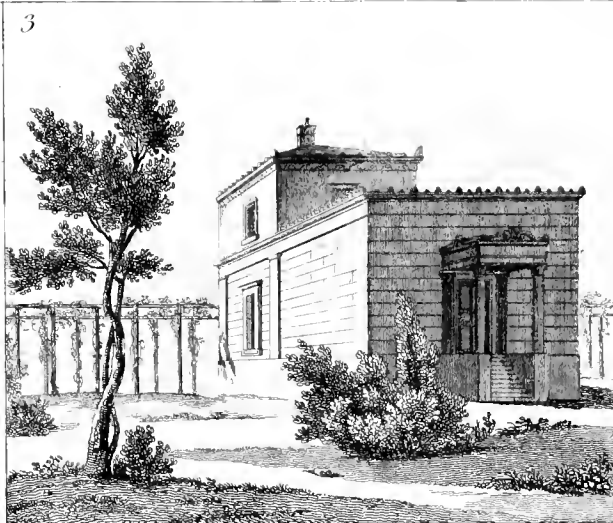
Soubassement.



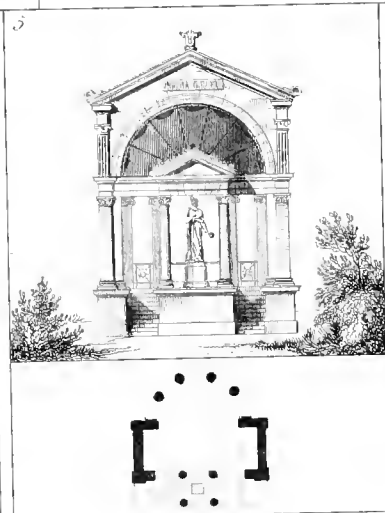
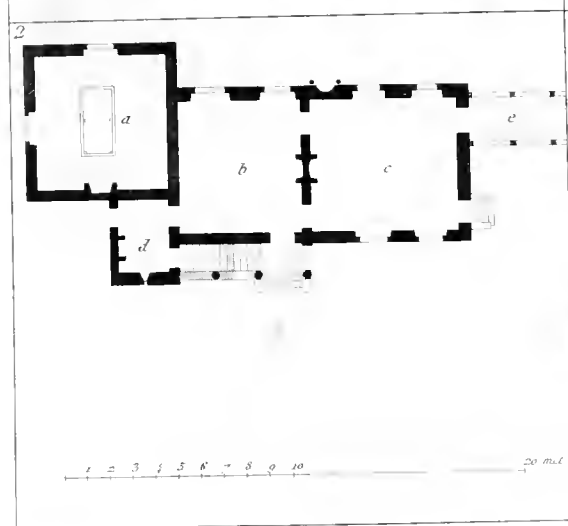
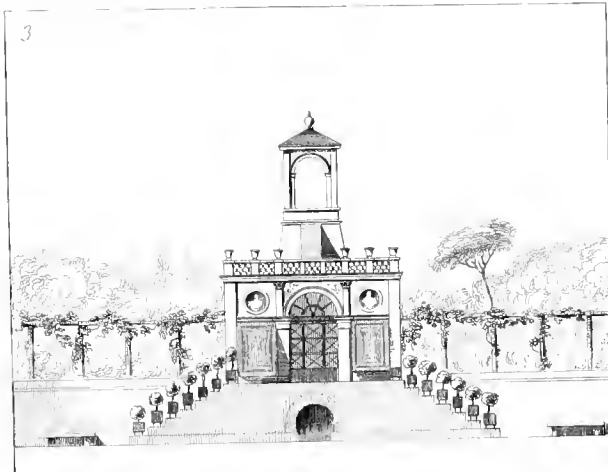
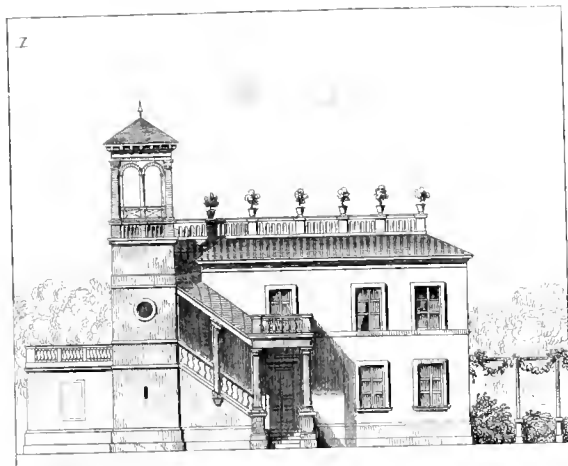
10 mètr.

Purou. 18

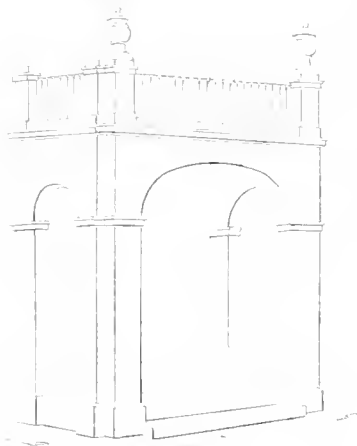
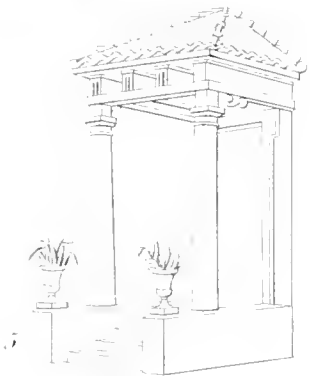
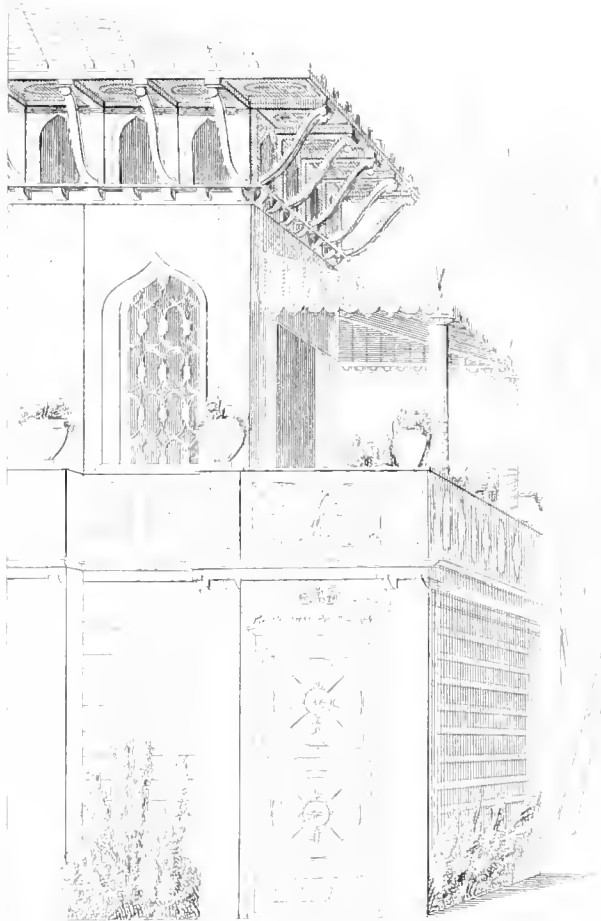
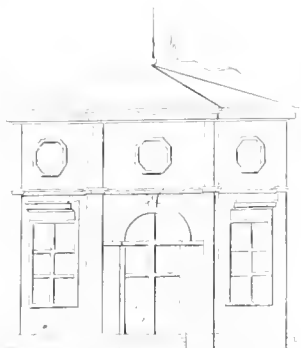














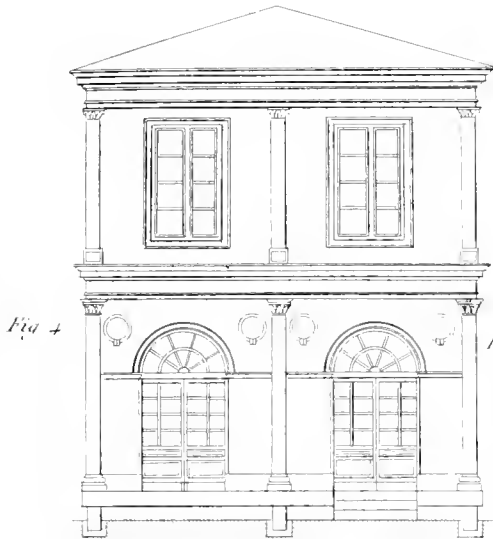


Fig. 4

Elevation

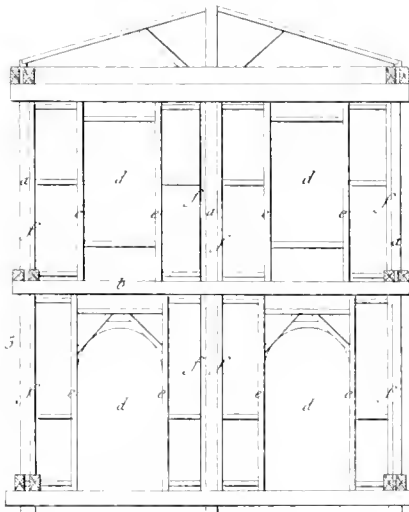


Fig. 5

Elevation des poteaux et chassis

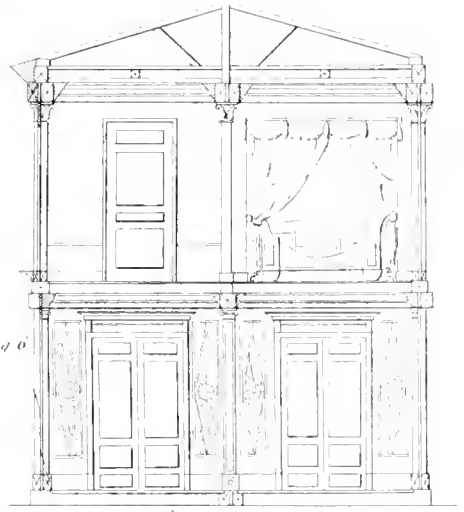


Fig. 6

Coupe en travers

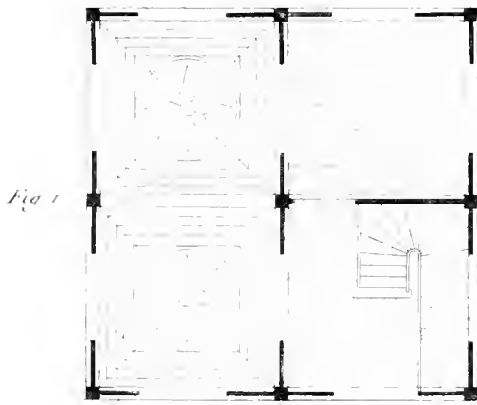


Fig. 1

Plan du rez-de-chaussée

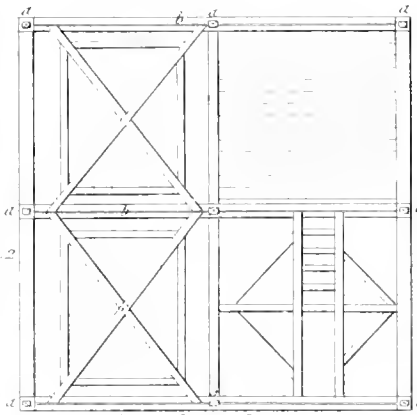


Fig. 2

Plan du dessous du parquet

1 2 3 4 mètres

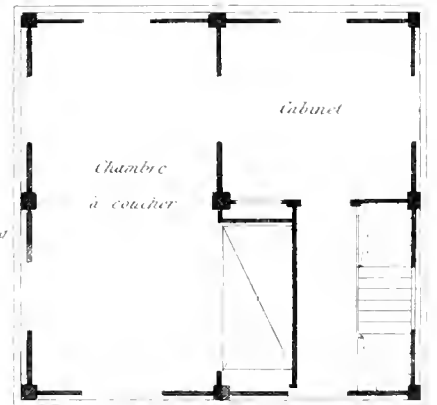
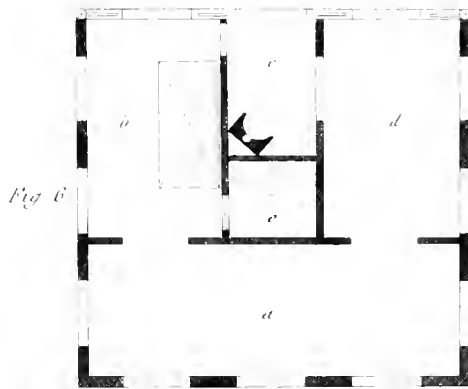
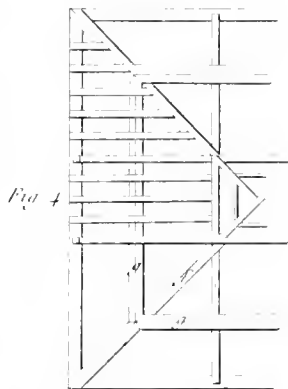
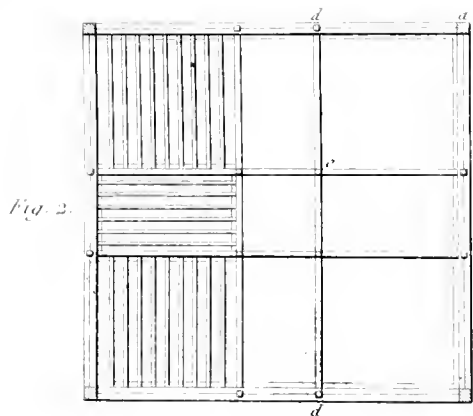
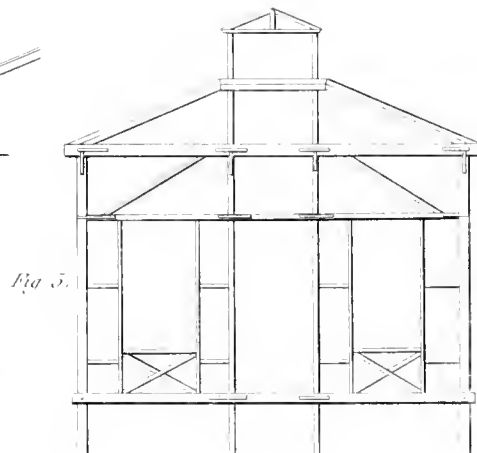
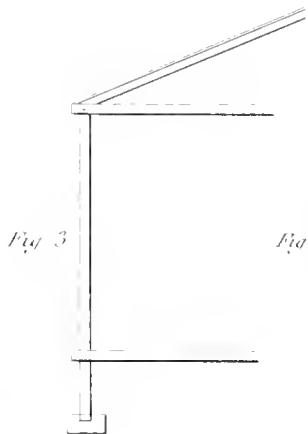
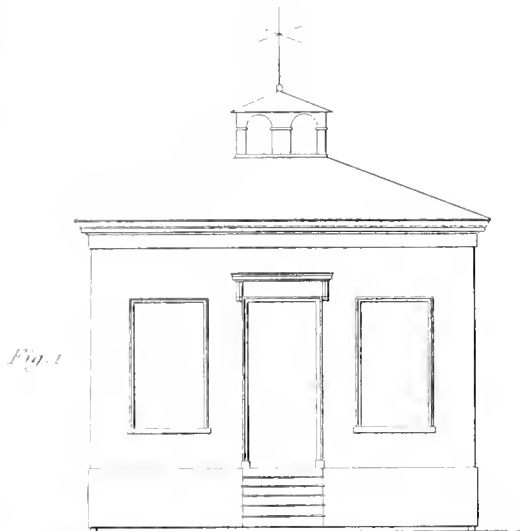


Fig. 3

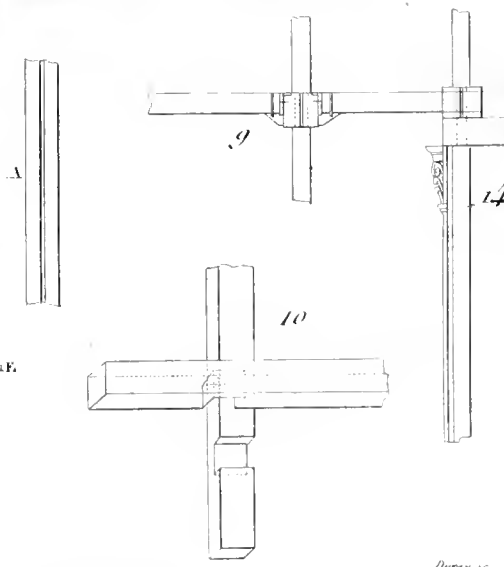
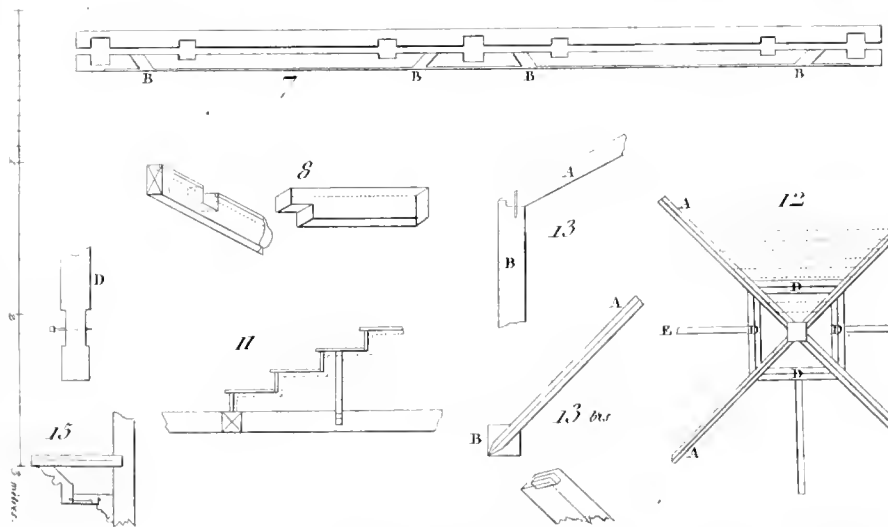
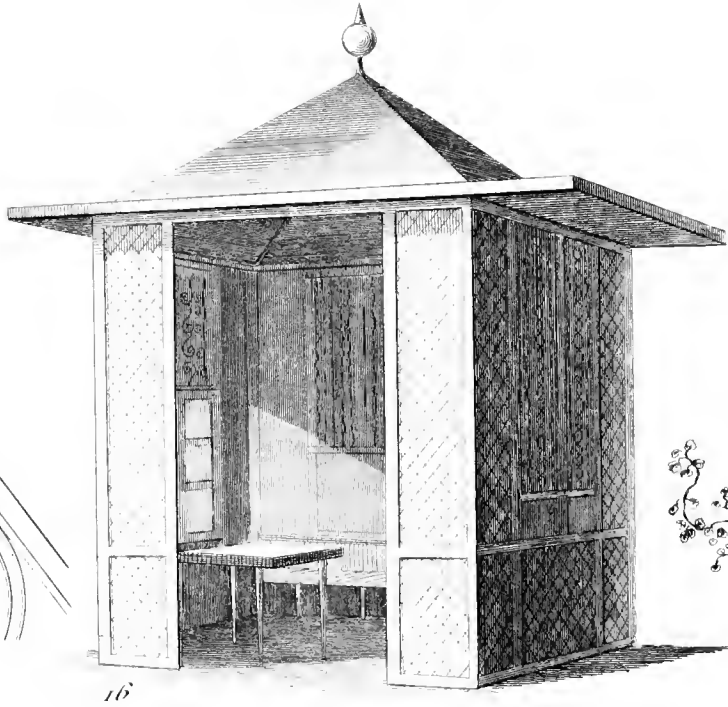
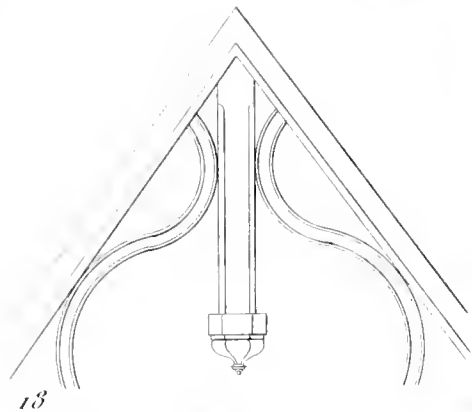
Plan du 1^{er} étage.





1 2 3 4 metros





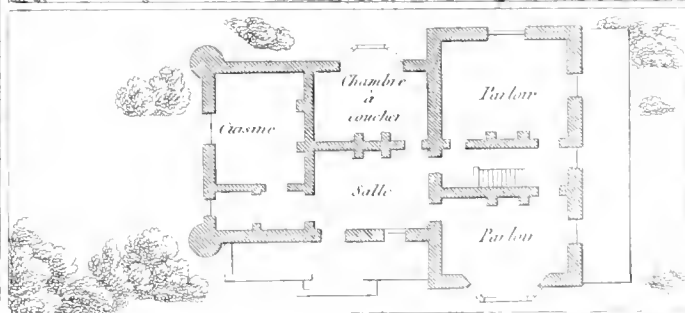
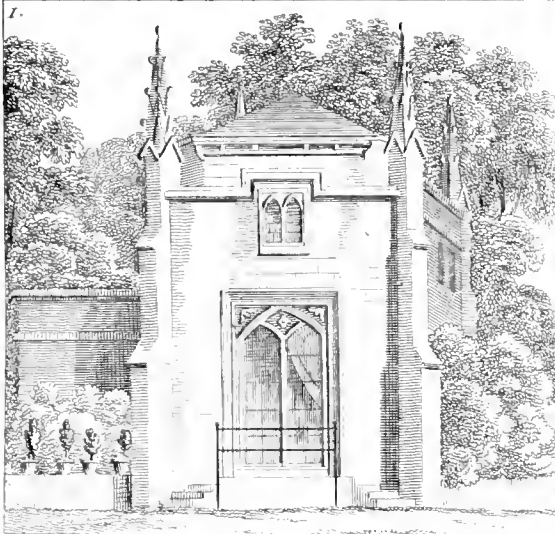
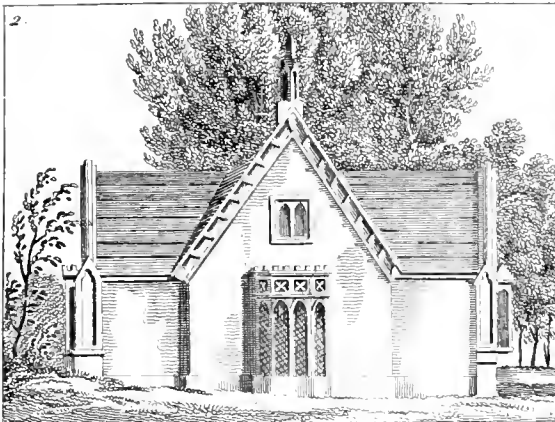
CABINET TRANSPORTABLE

DÉTAILS DES MAISONS.

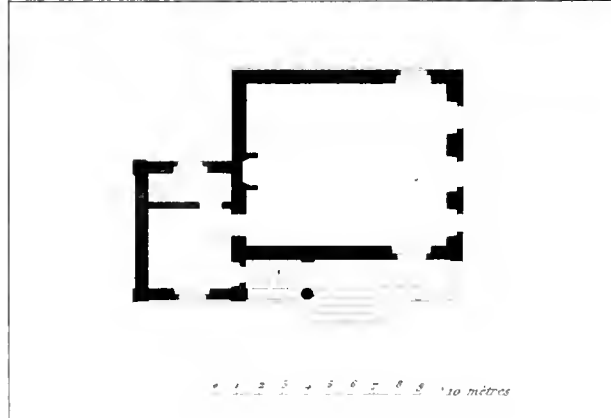
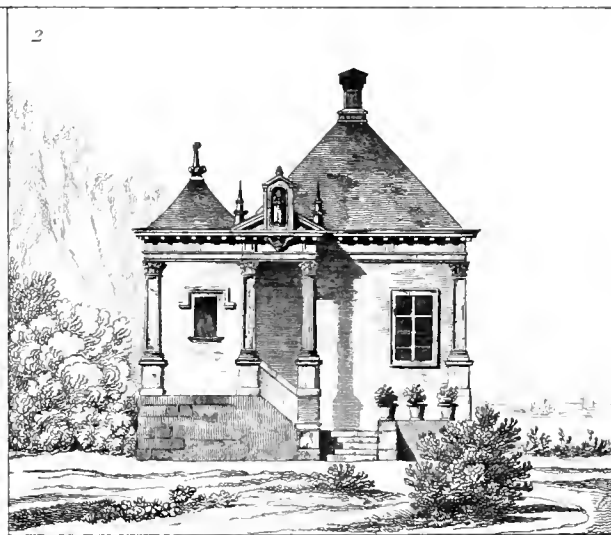
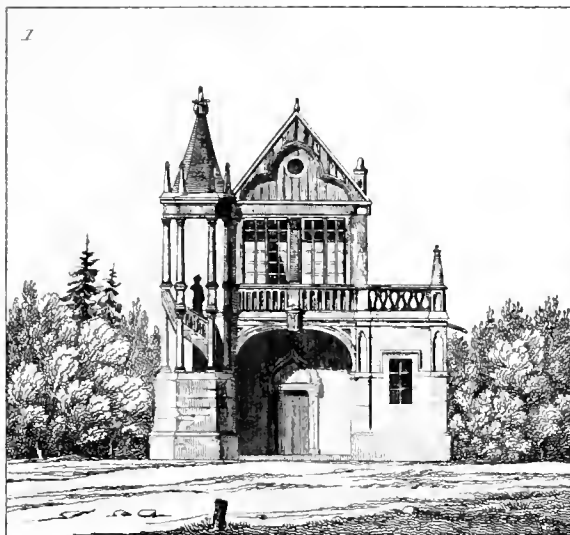
VASE RUSTIQUE.

Dupou sc

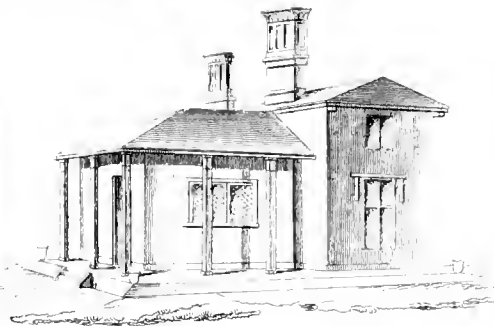
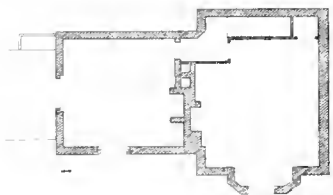
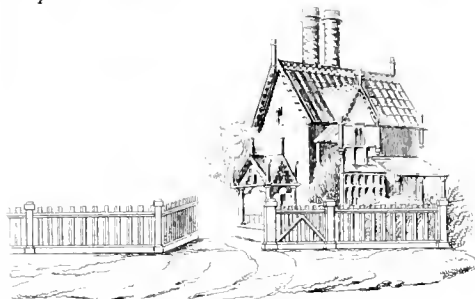
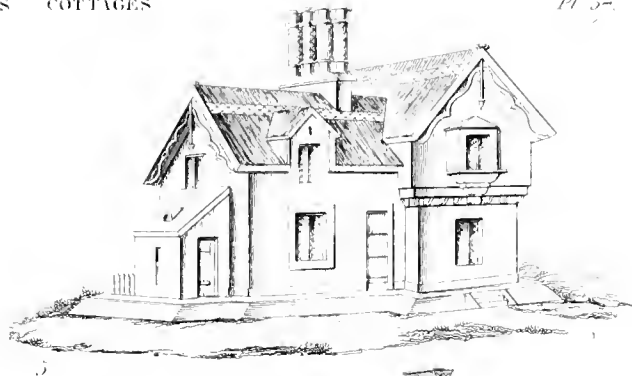
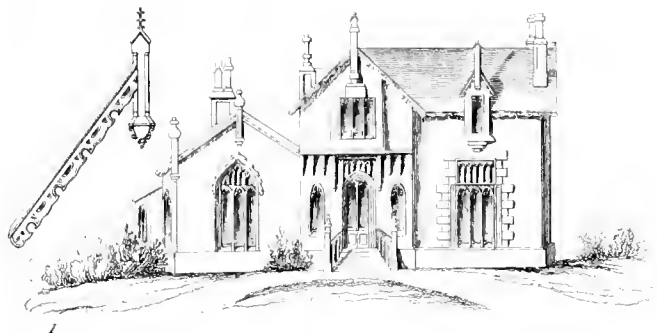




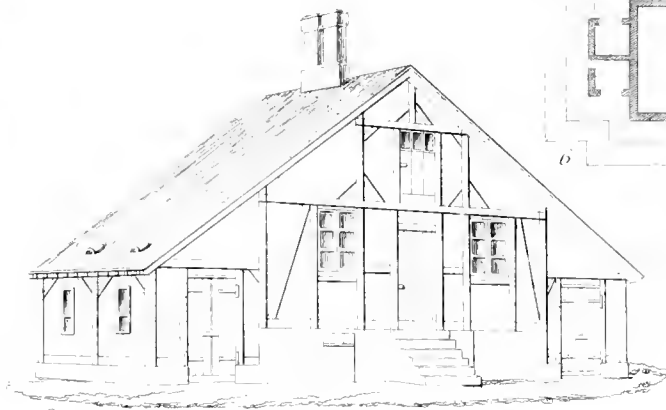
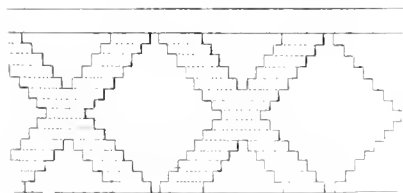
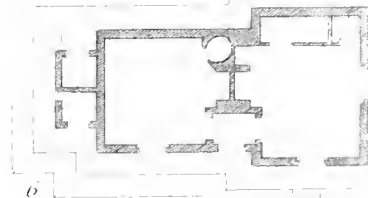
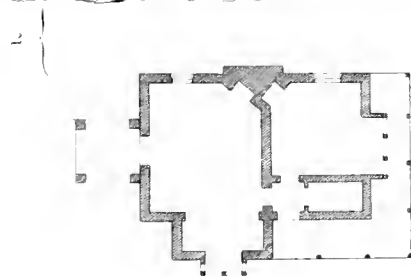








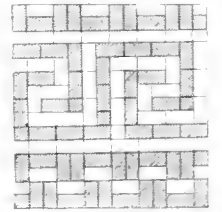
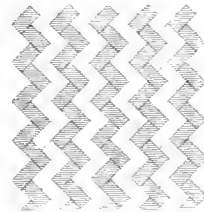
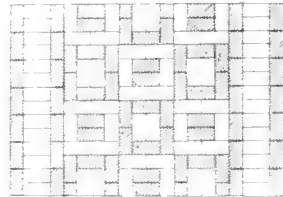
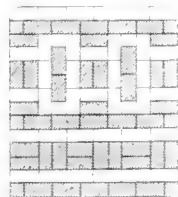
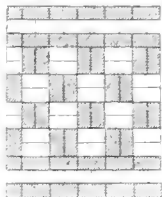
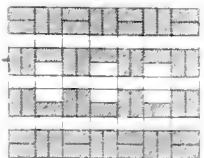
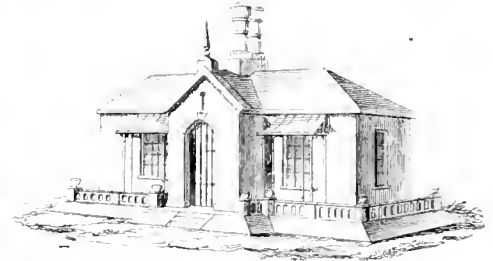
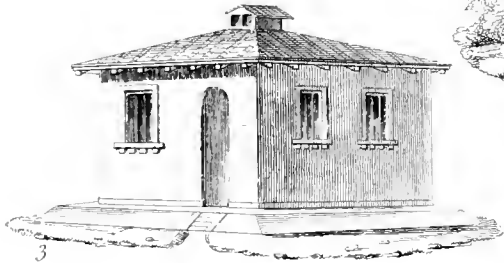
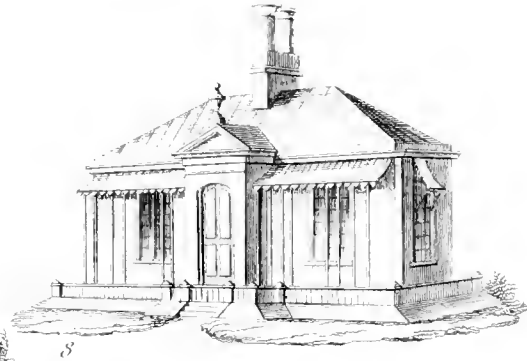
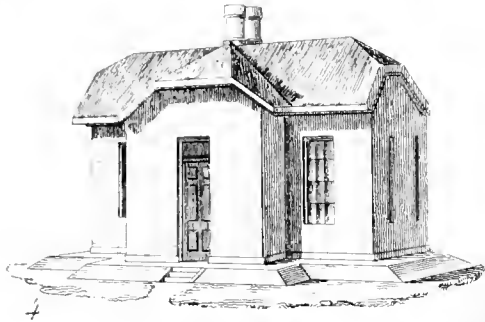
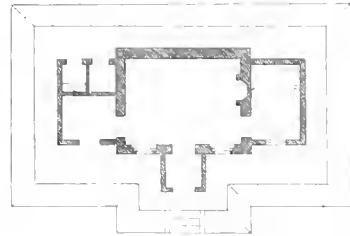
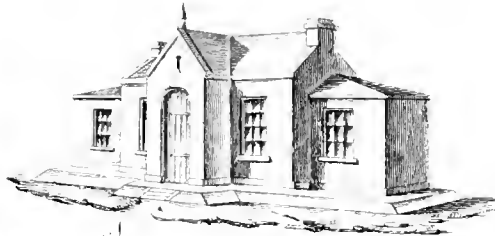
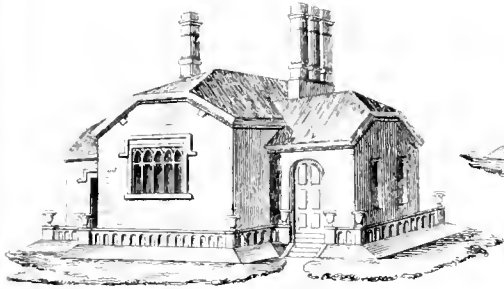
18 pieds

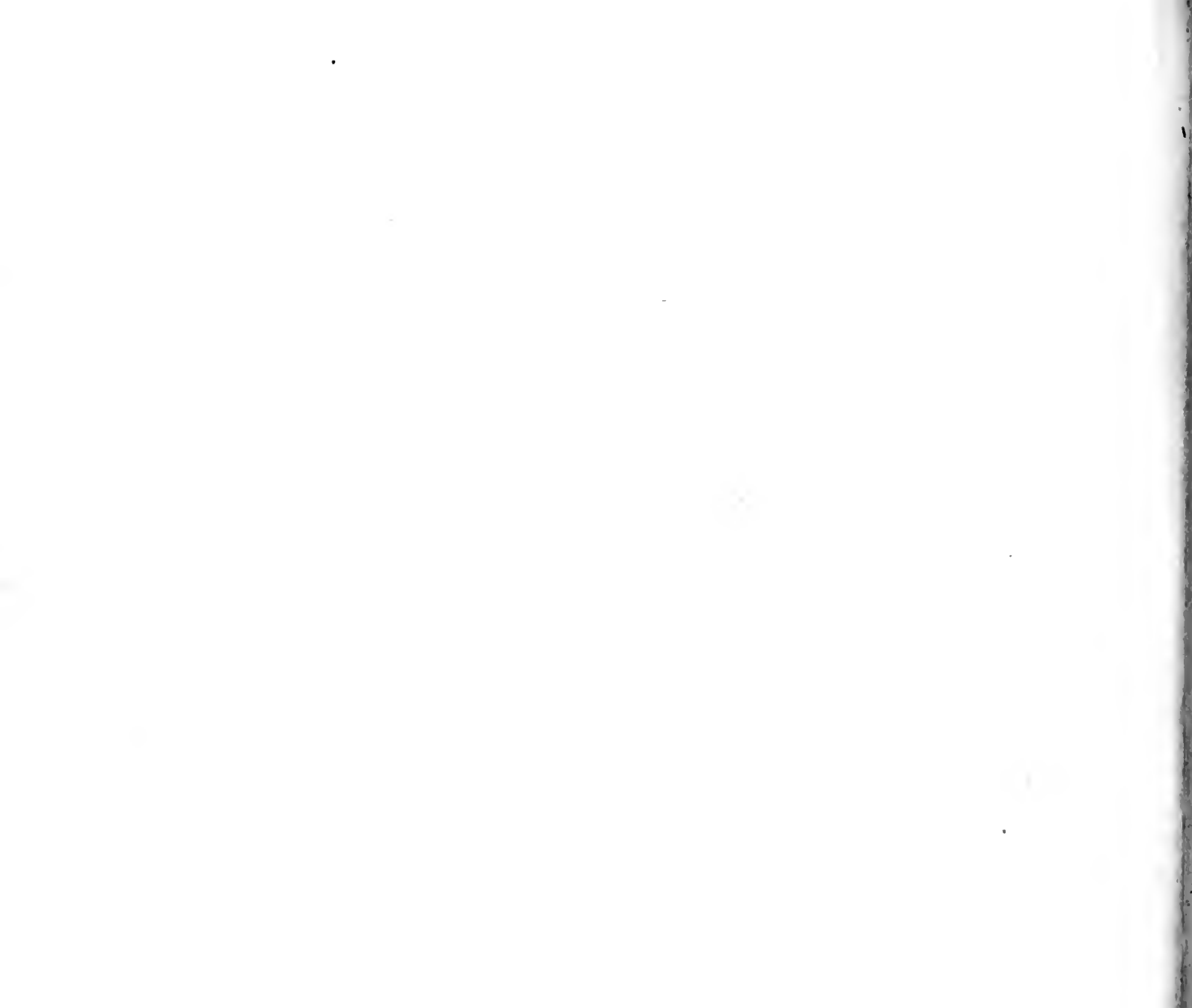


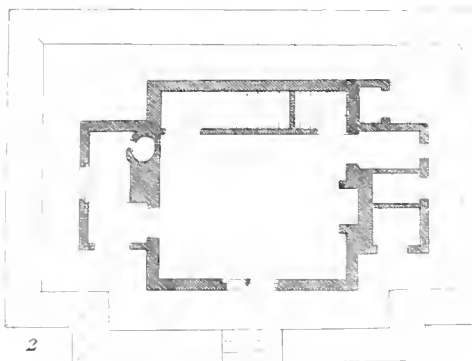
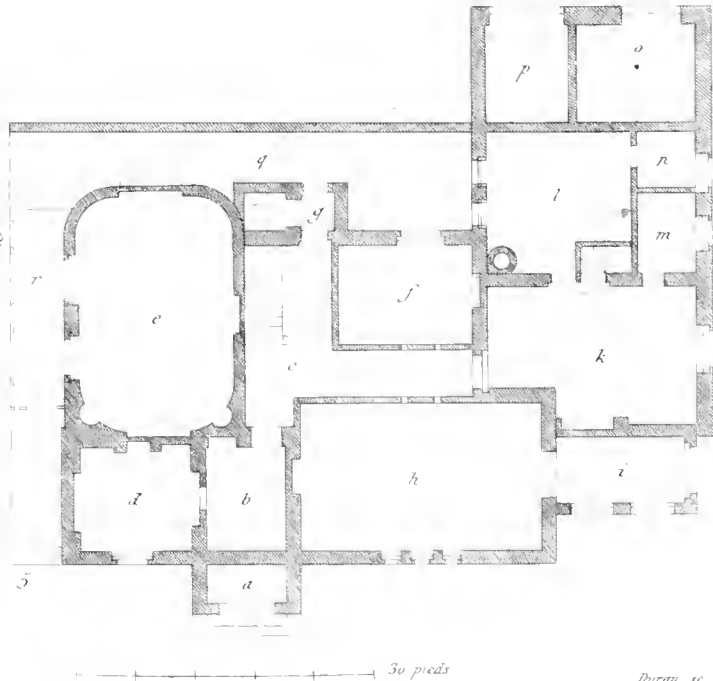
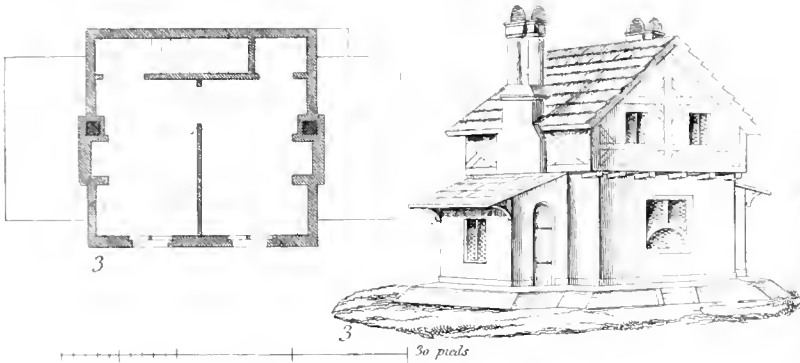
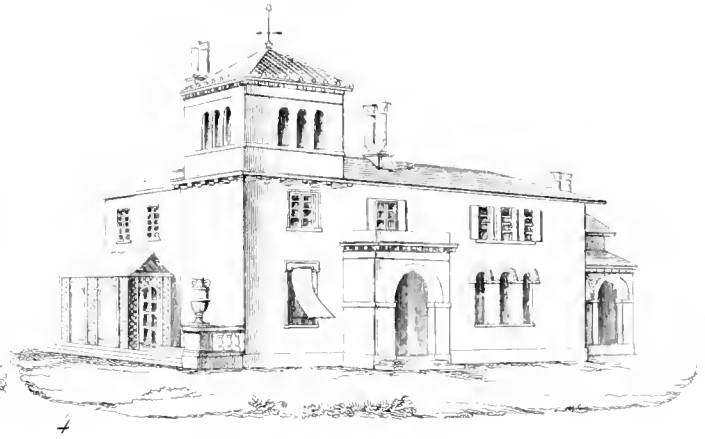
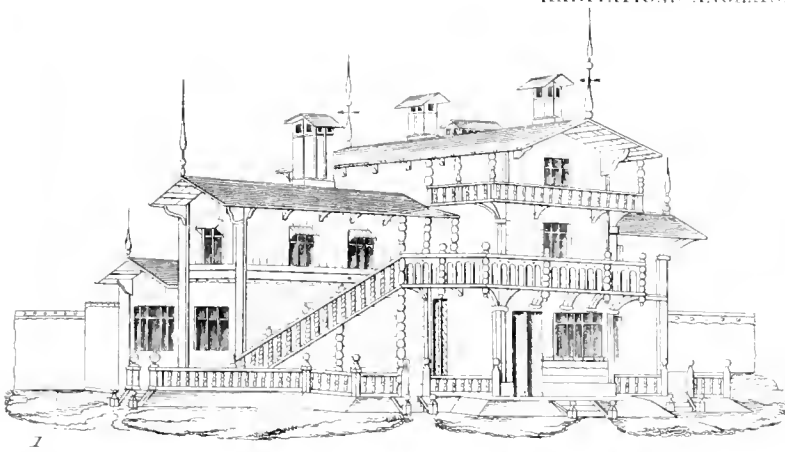
8 London Encyclop. of Cottages

9

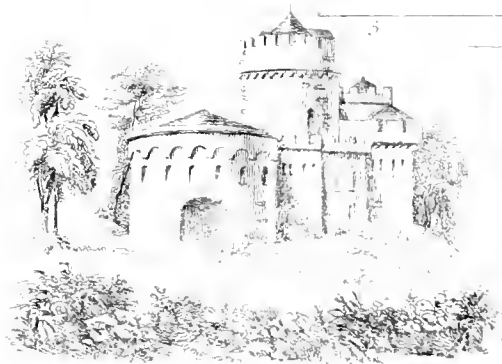
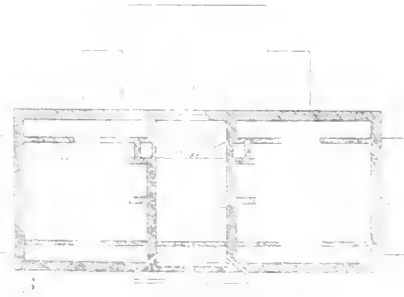
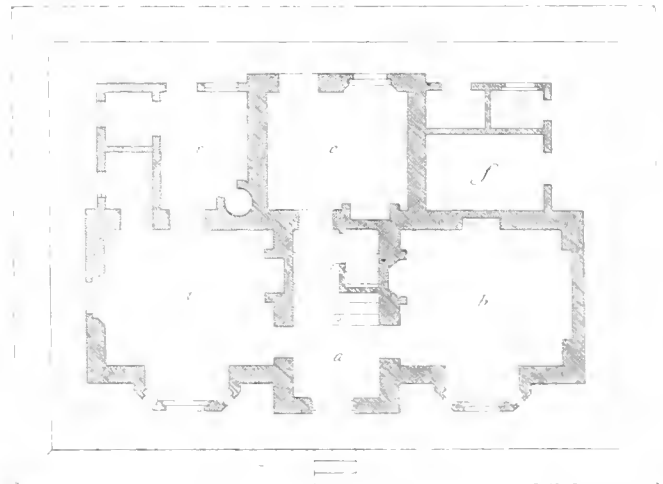
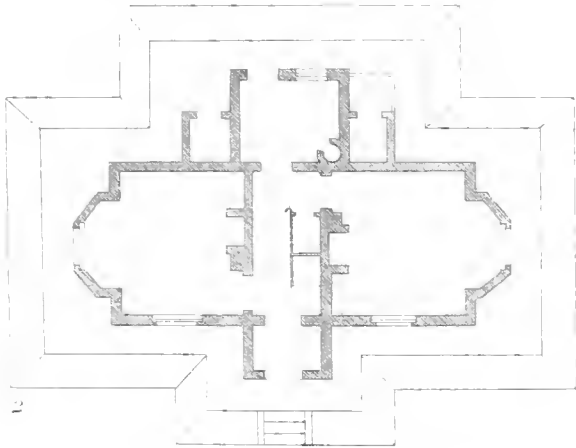
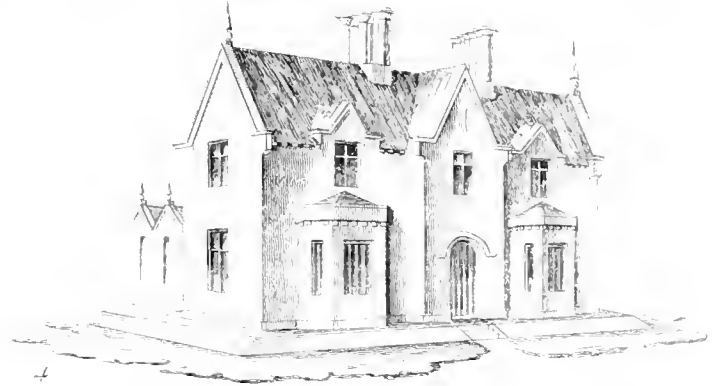
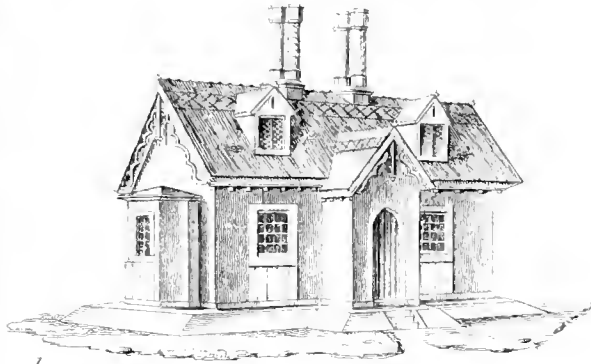




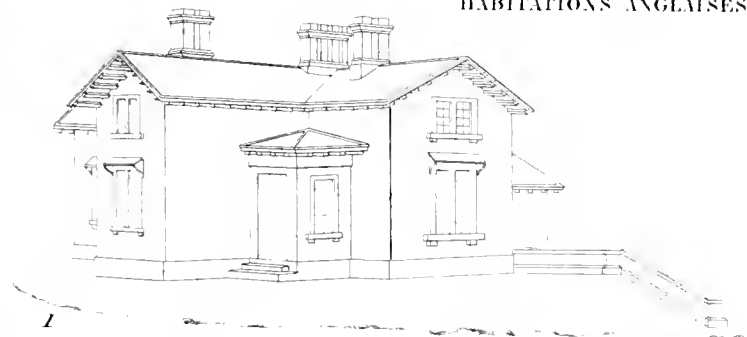




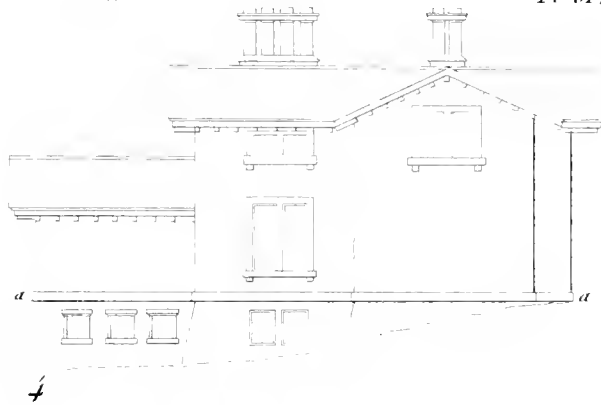








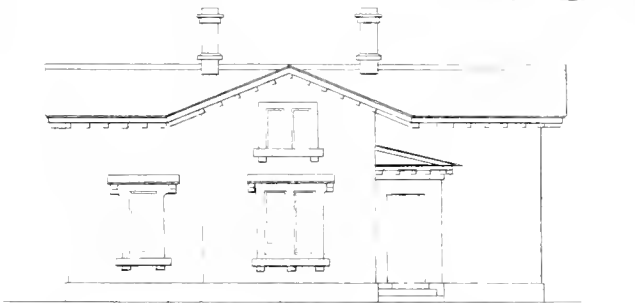
1



a

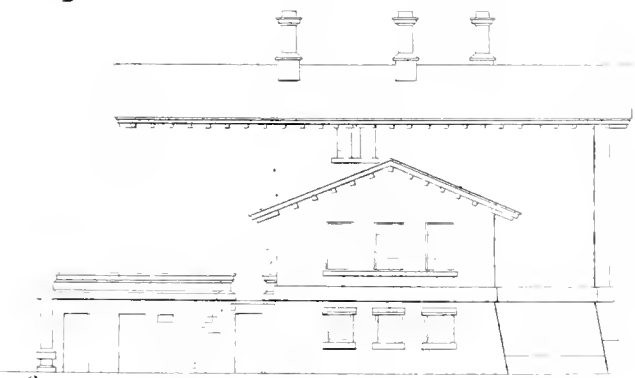
a

4



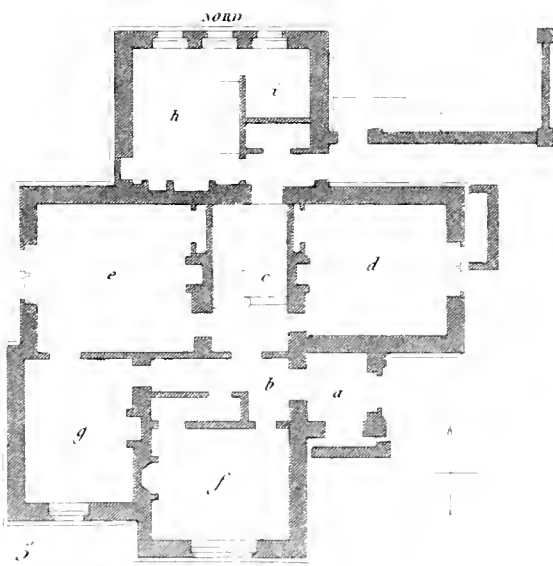
2

SUD.



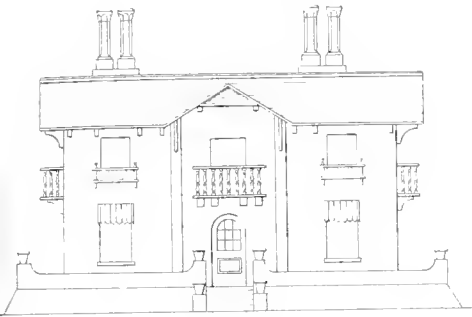
3

NORD.

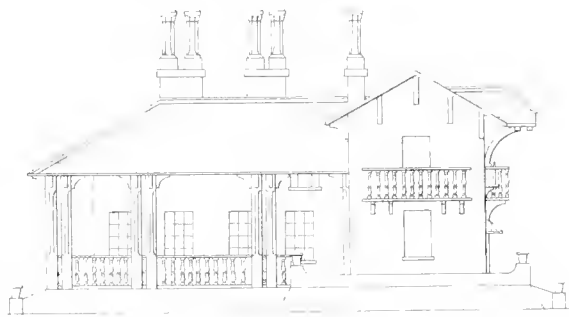


5

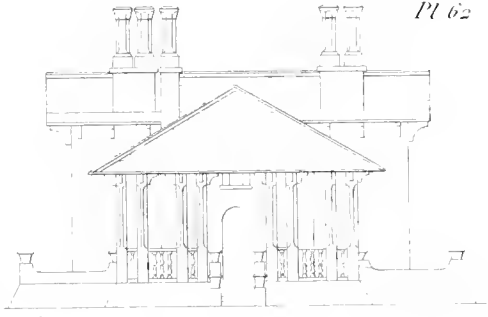




2



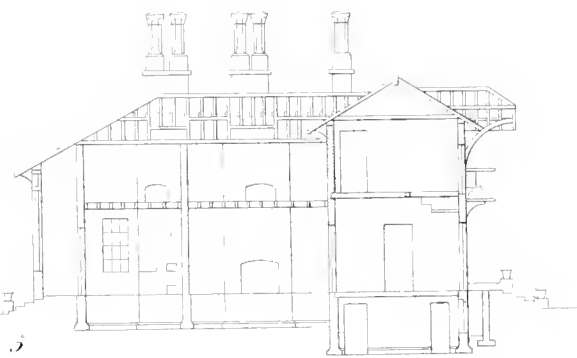
3



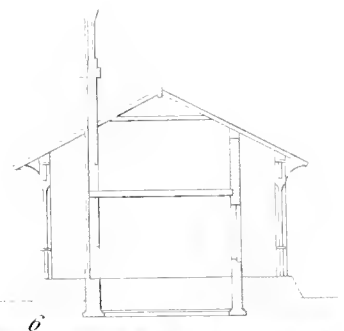
4



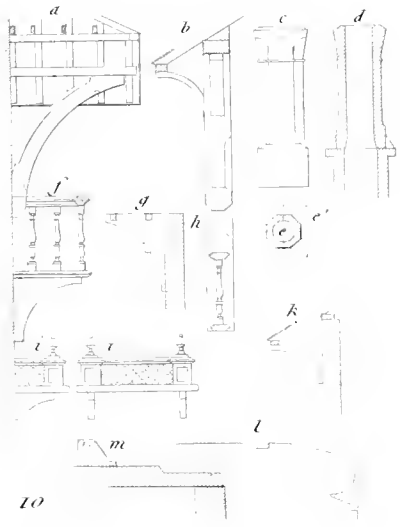
1



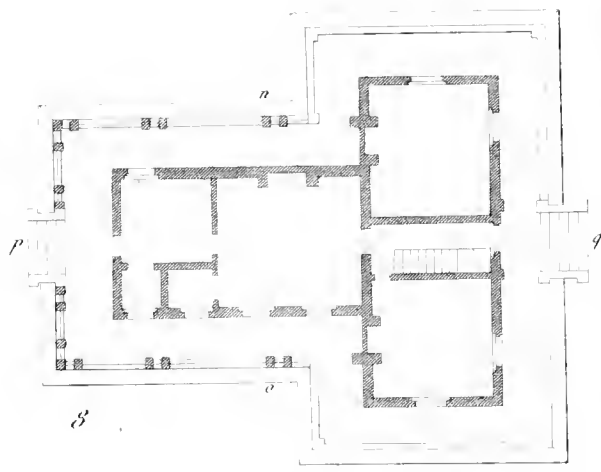
5



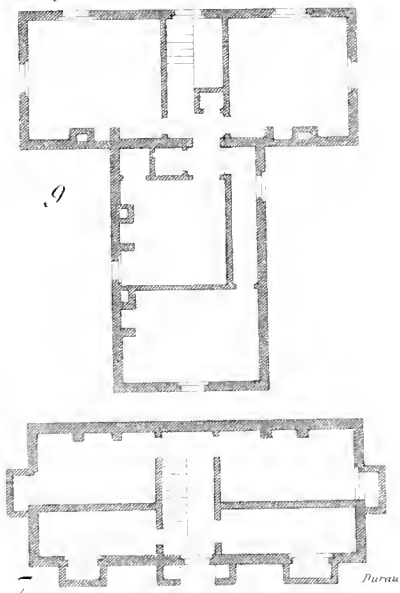
6



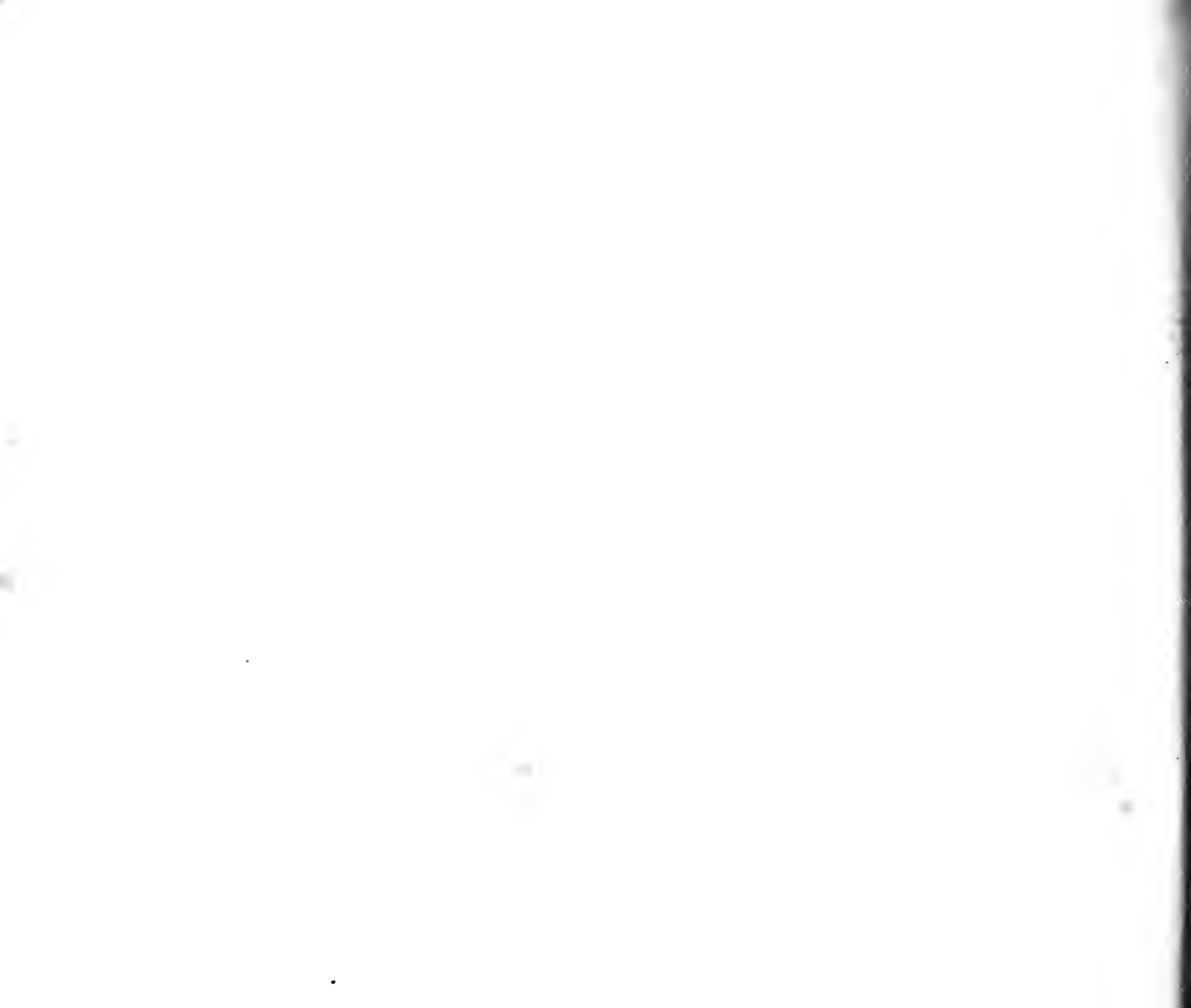
10



8



9





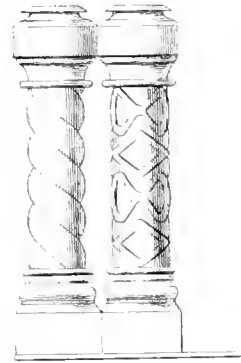
21



22



23



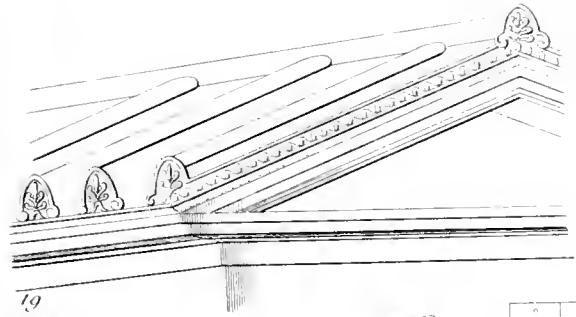
24



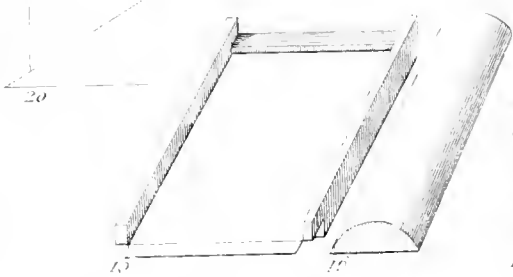
25



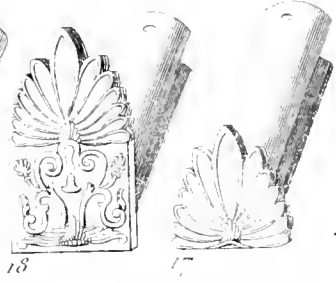
26



19

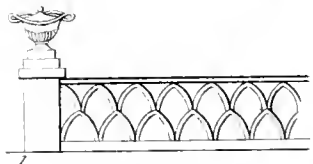


20

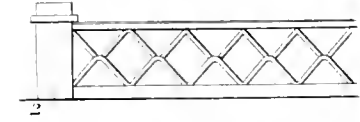


18

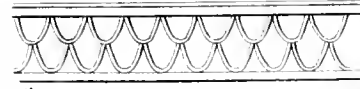
17



1



2



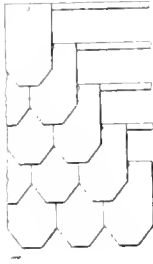
3



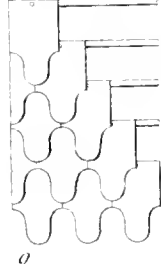
4



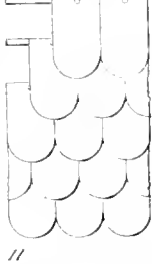
5



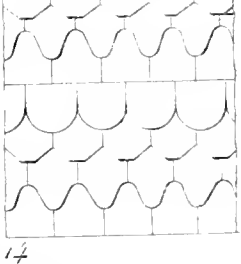
7



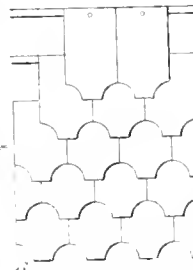
9



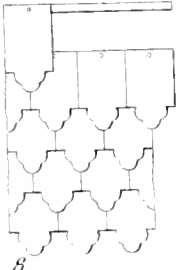
11



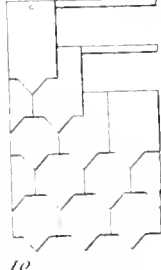
14



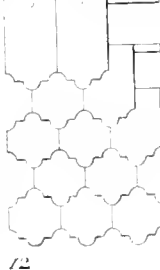
6



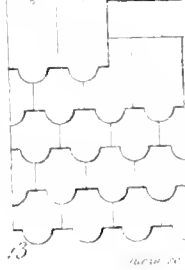
8



10

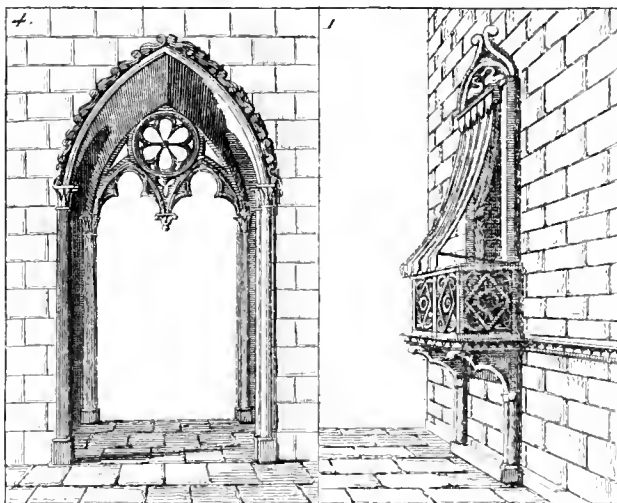
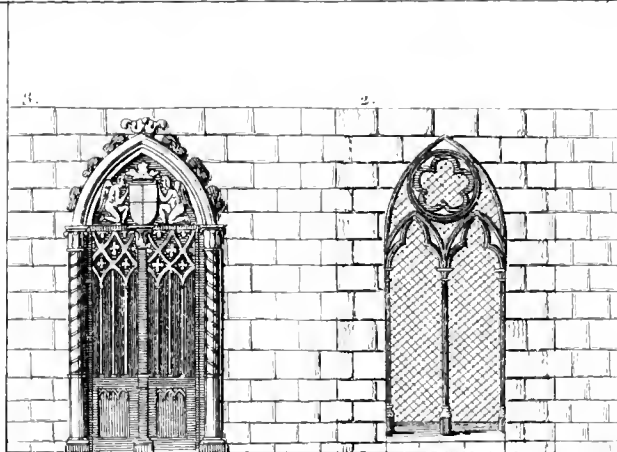
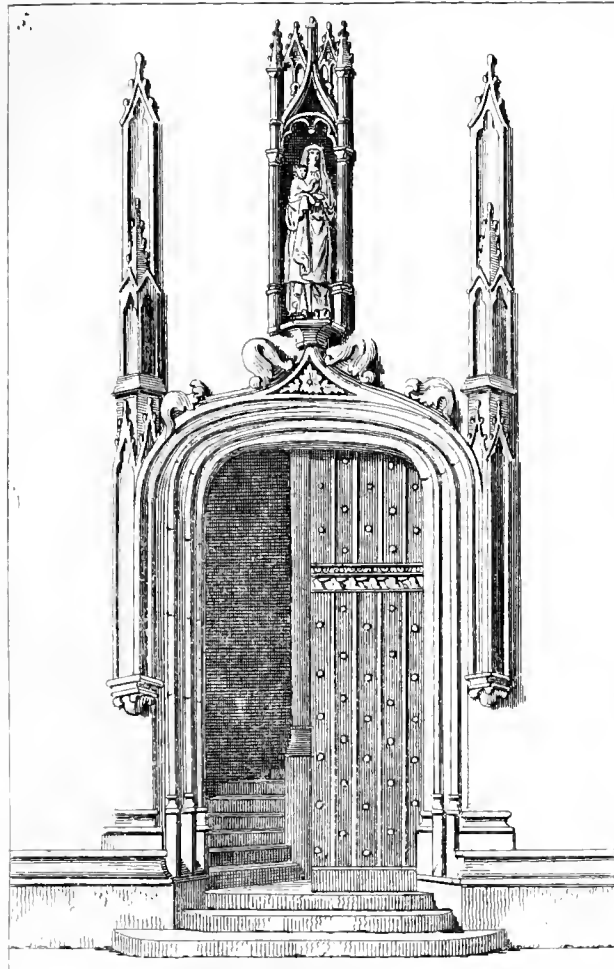


12

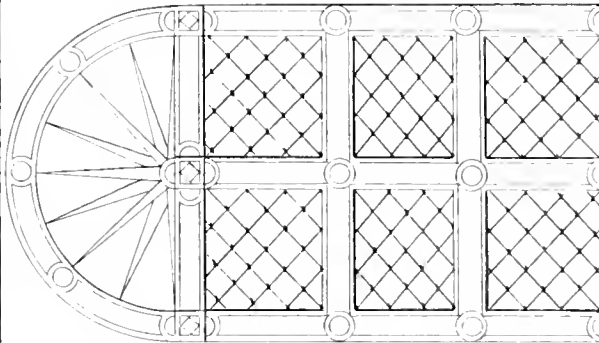
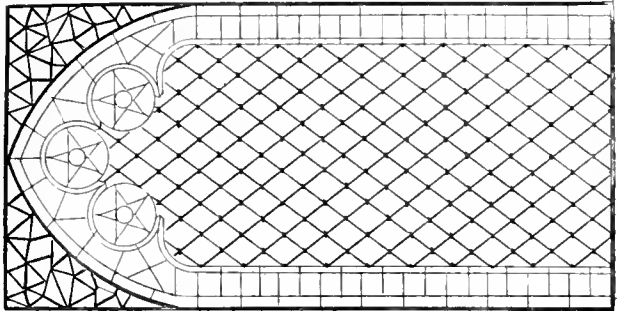
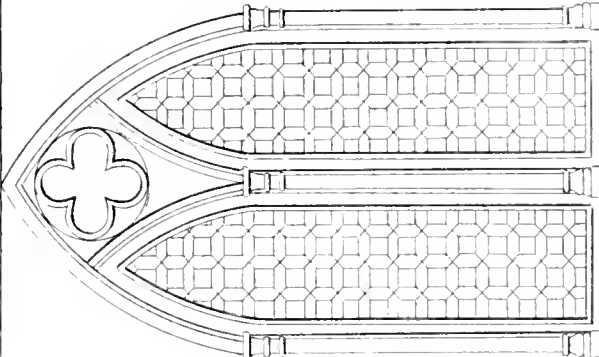
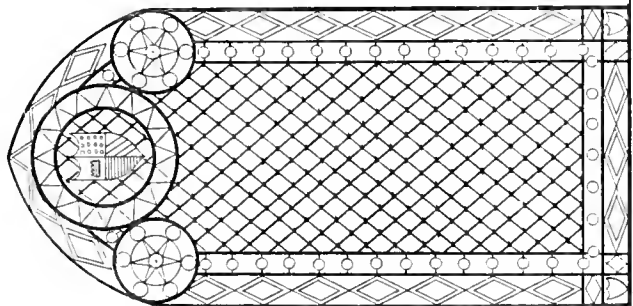
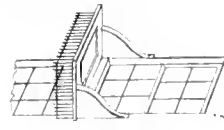
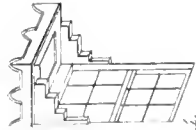
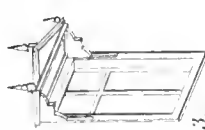
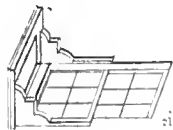
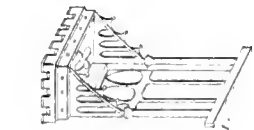


13

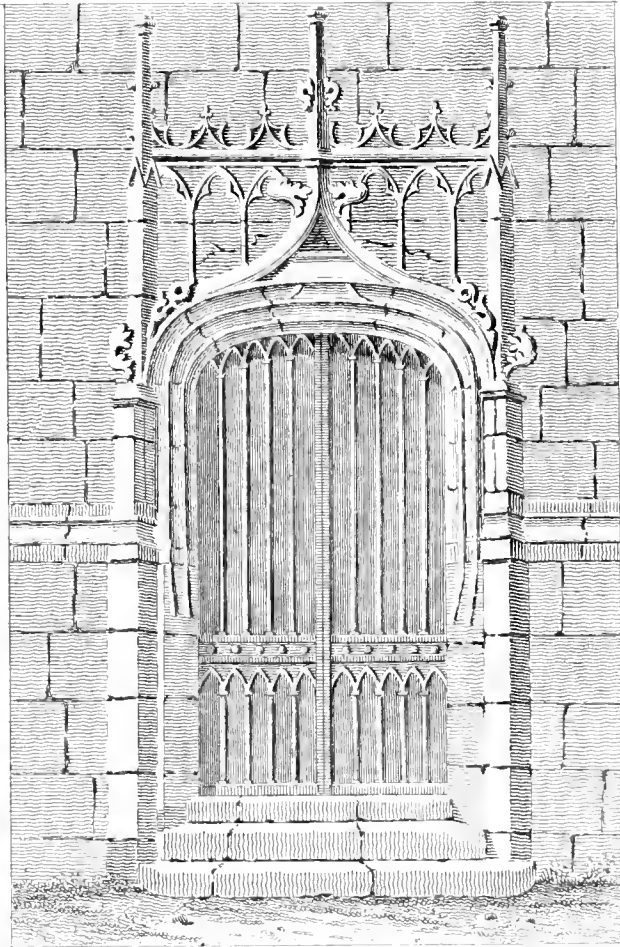
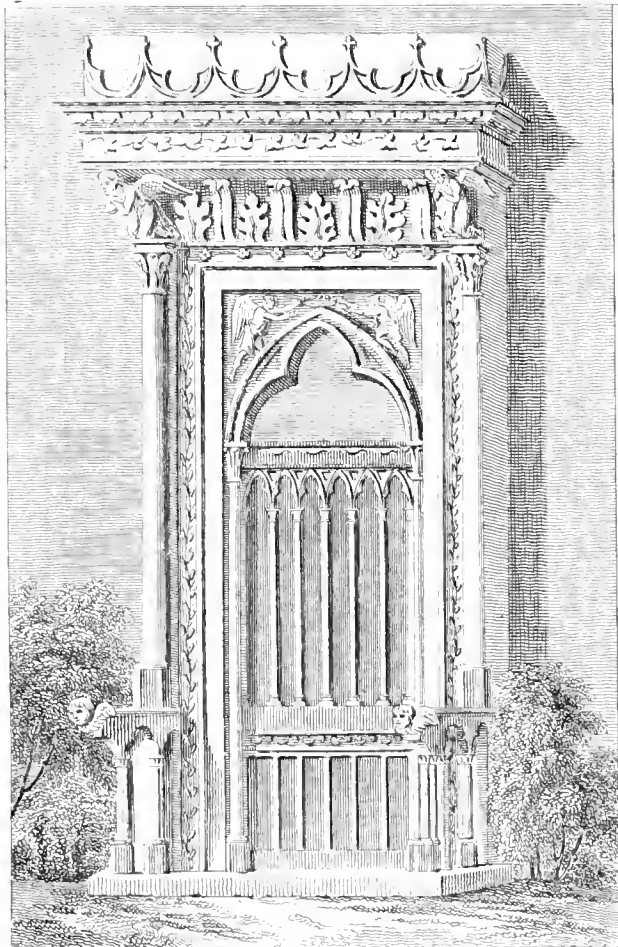






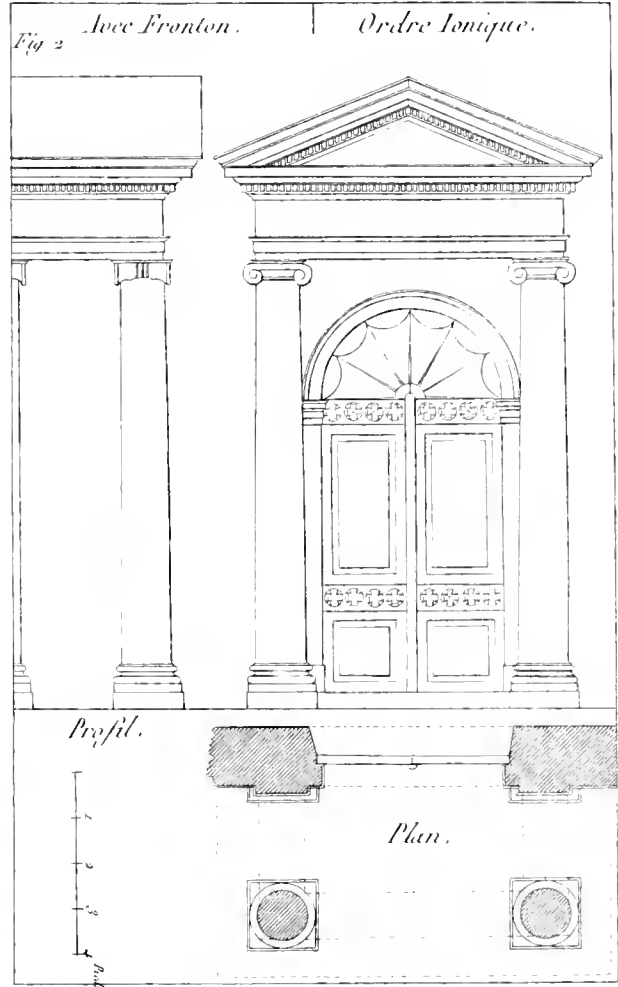
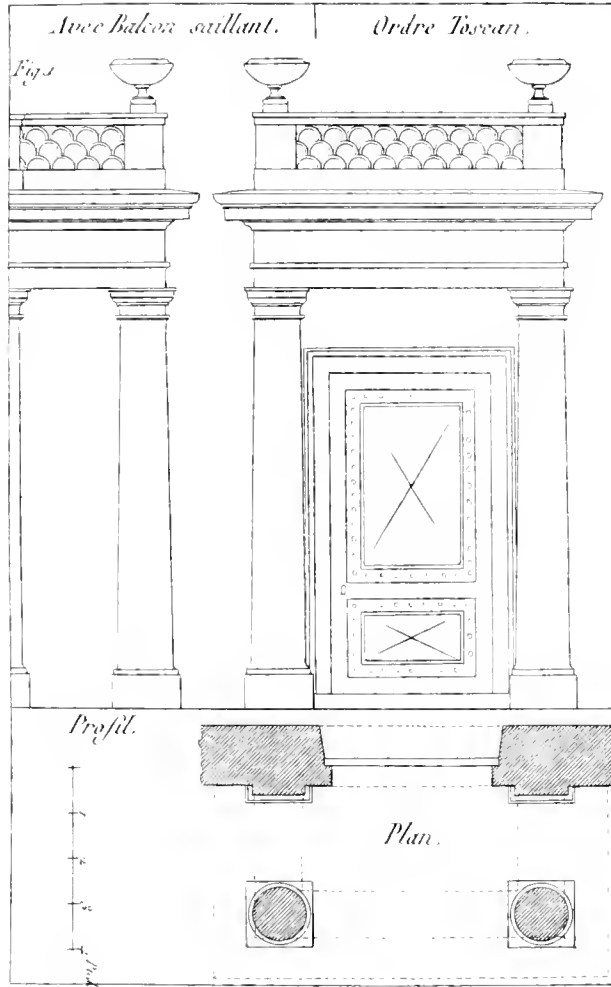




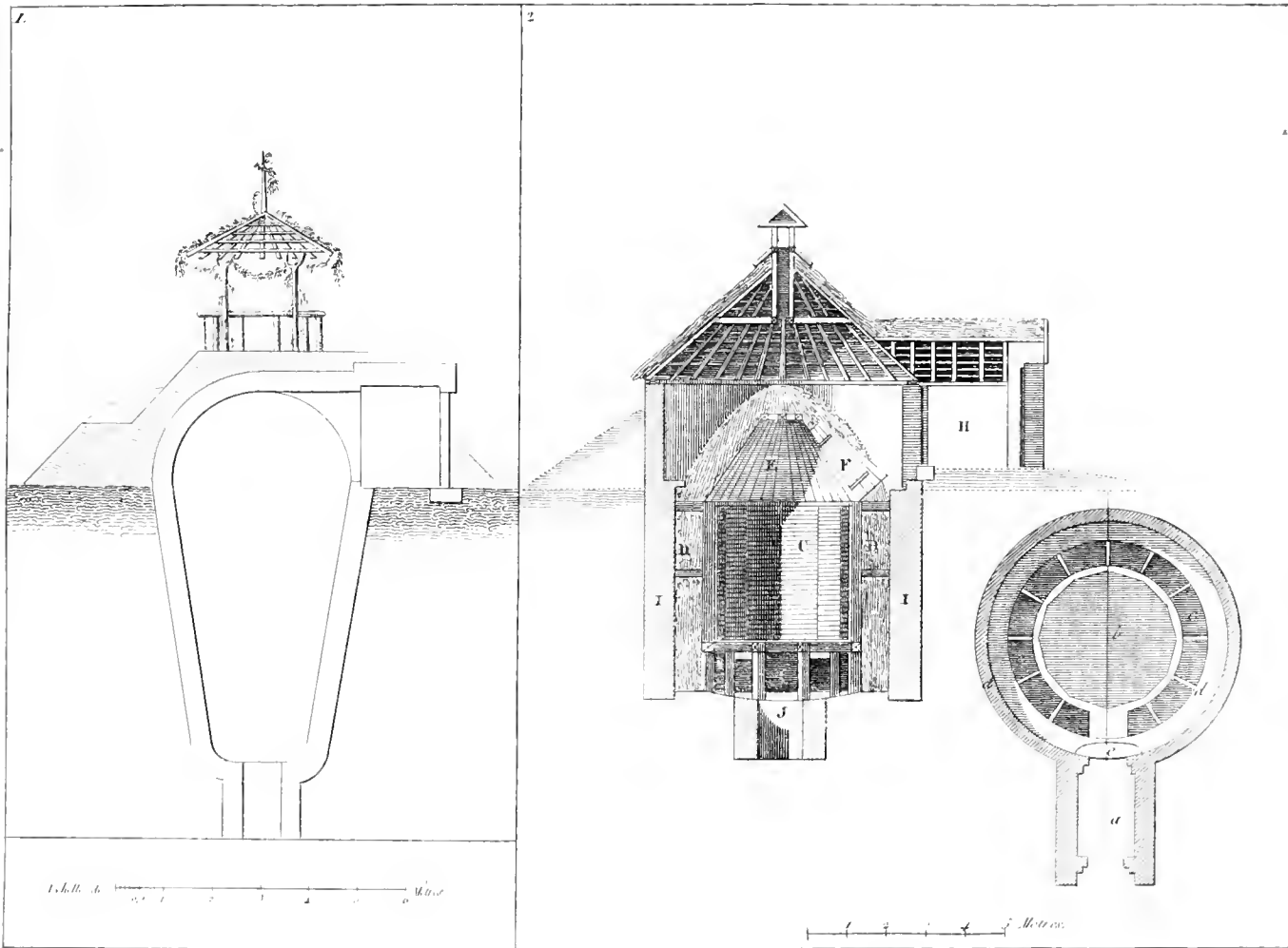


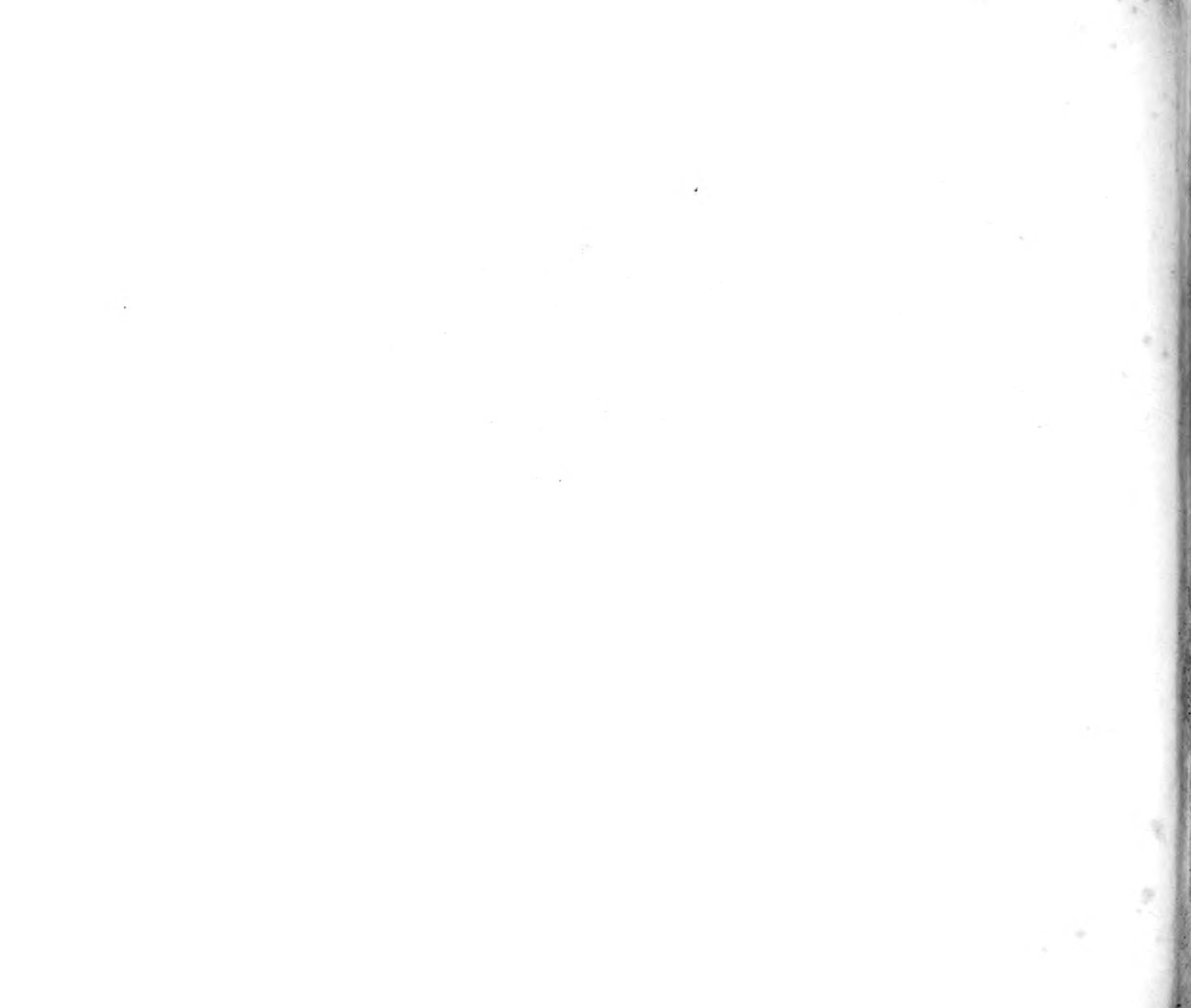
Pl. 66.

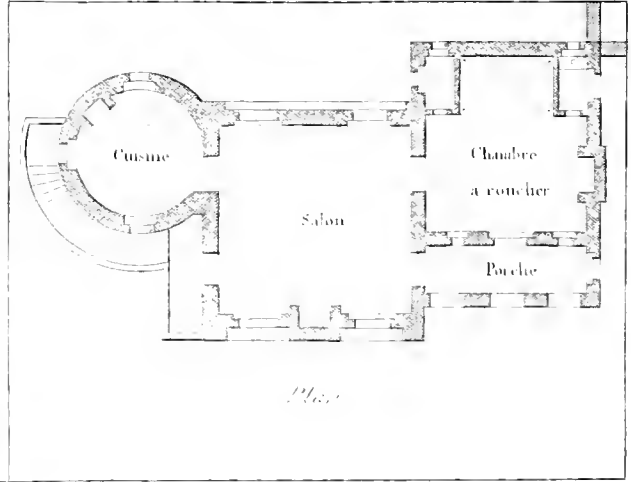
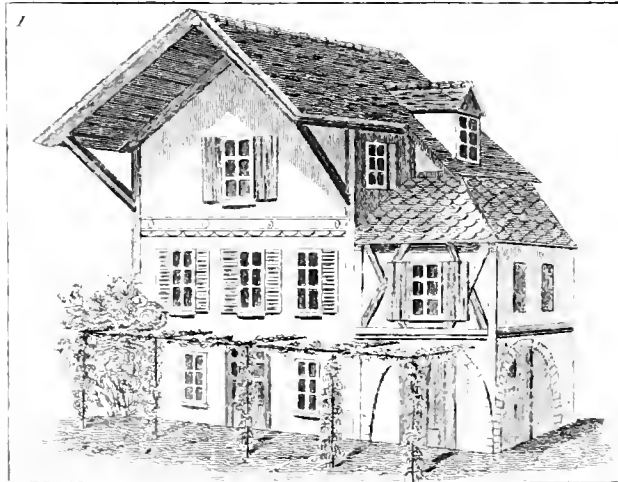
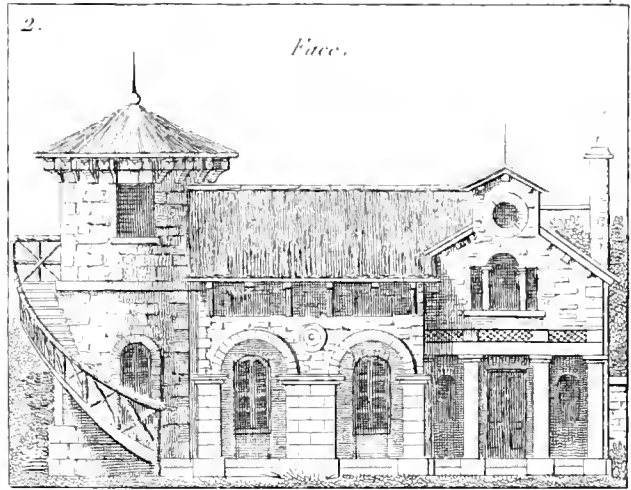
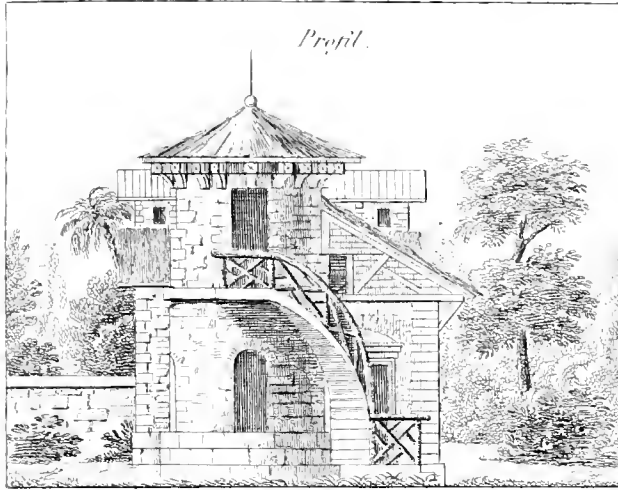




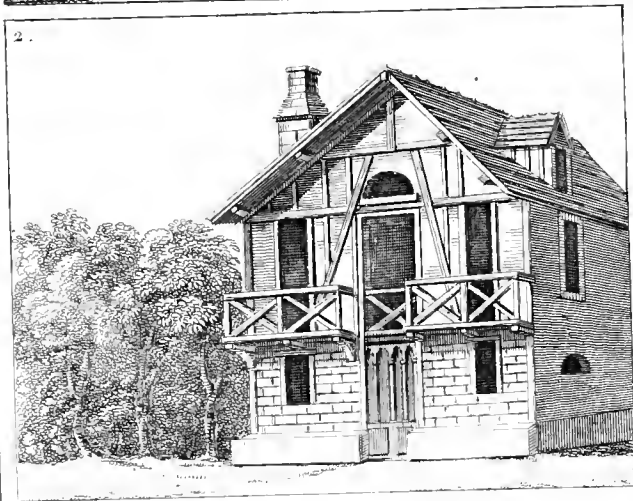
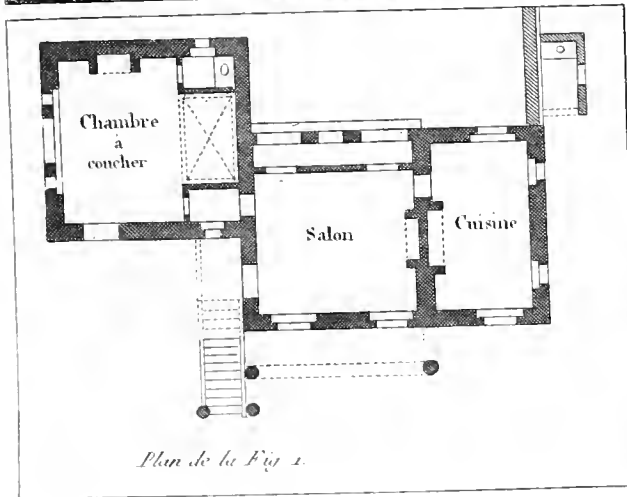
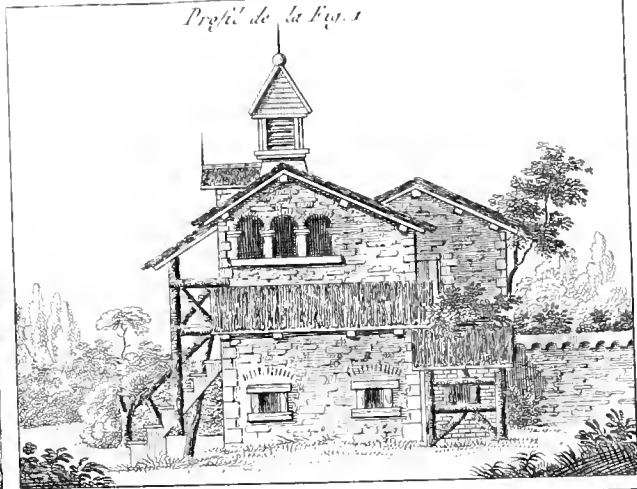
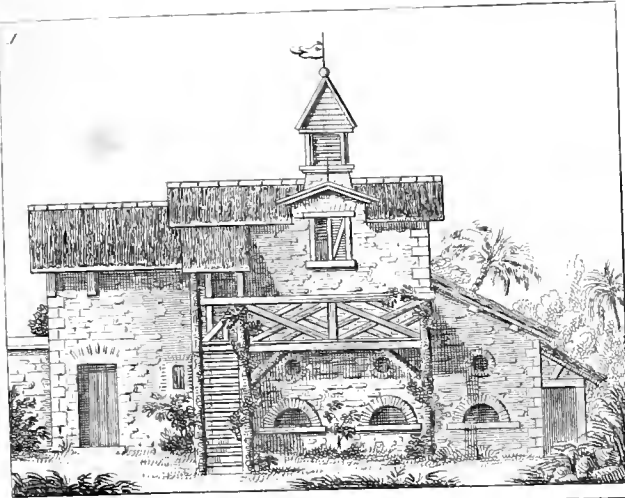




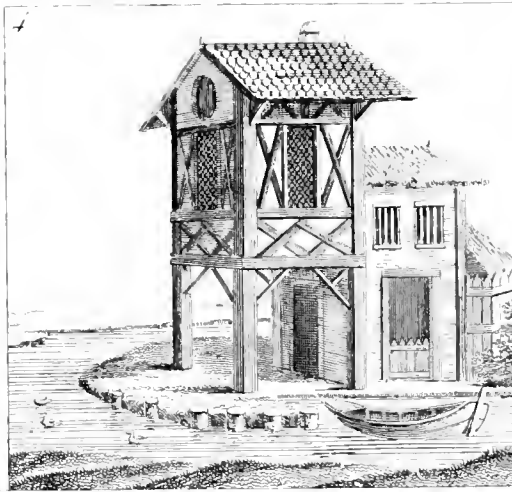
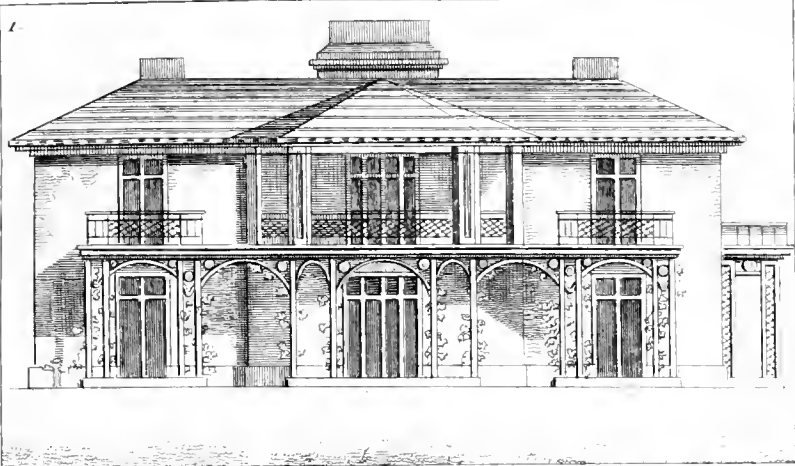


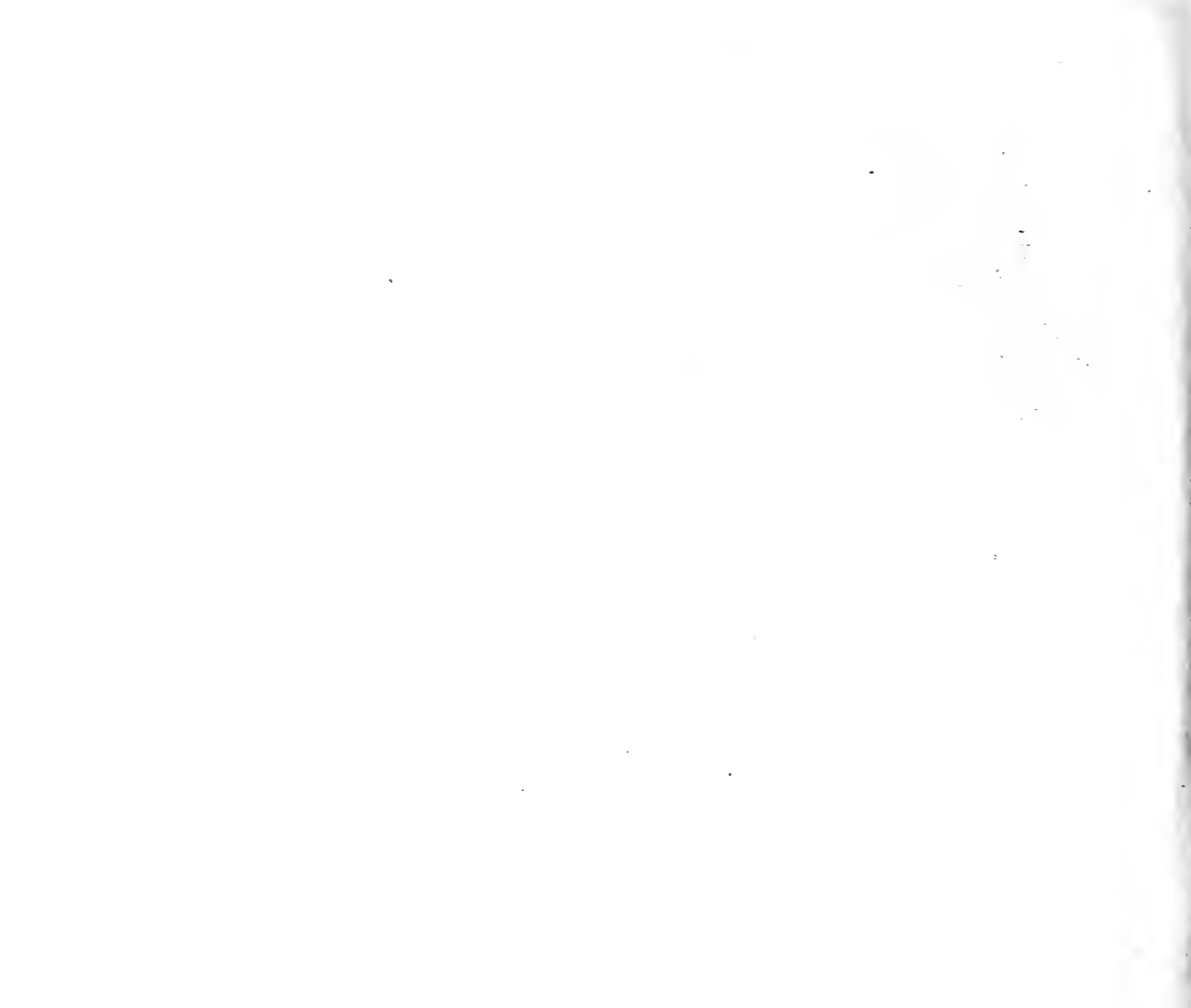


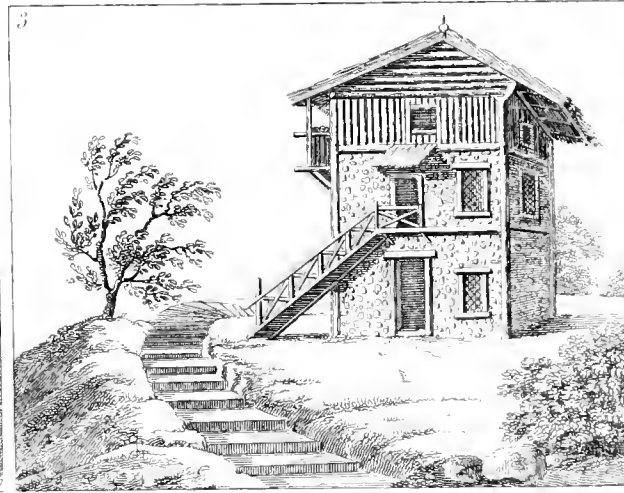
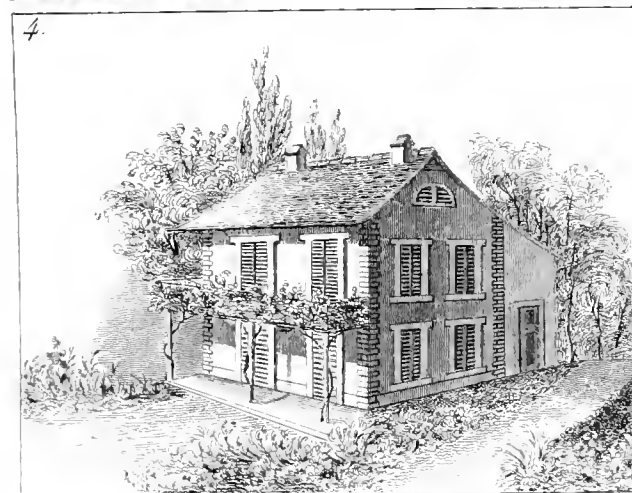
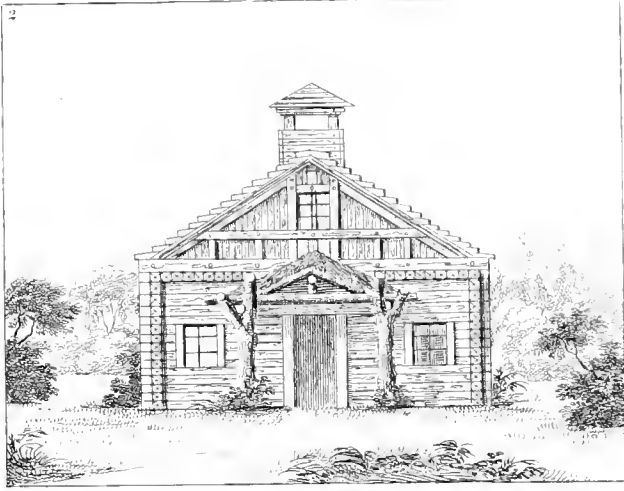
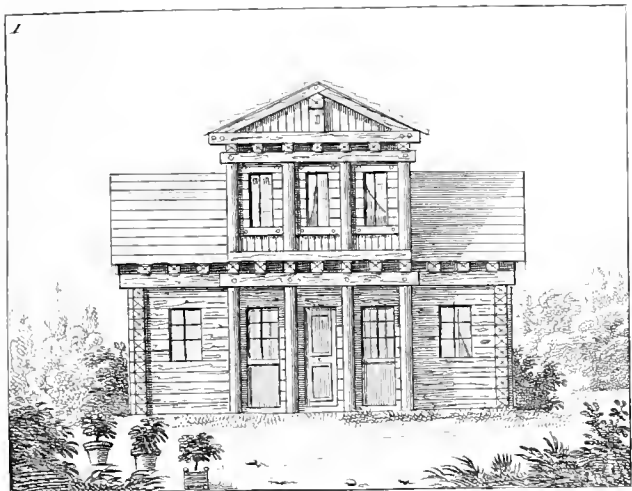














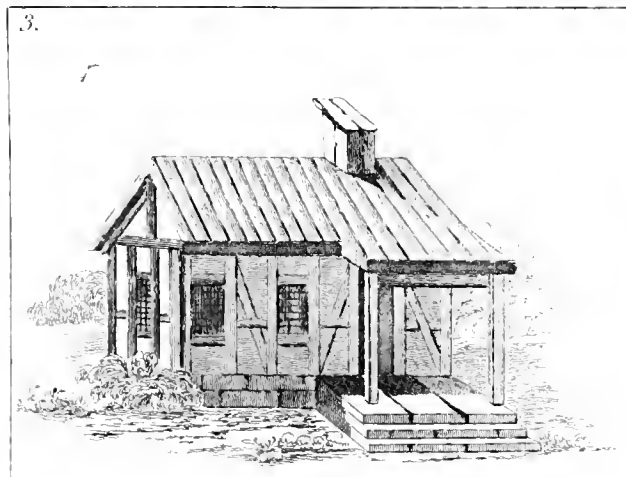
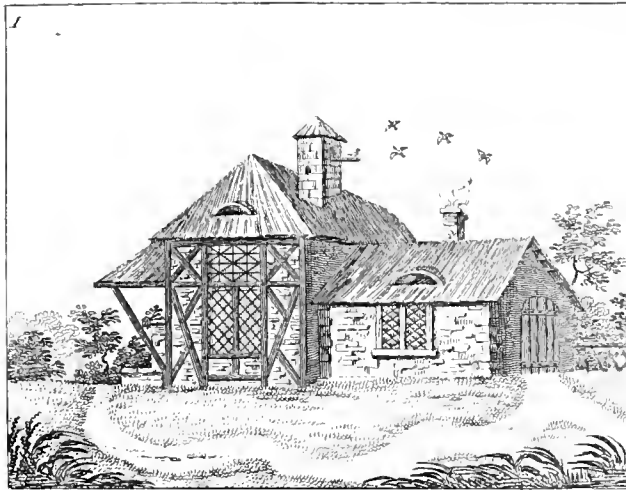




Fig. 1.

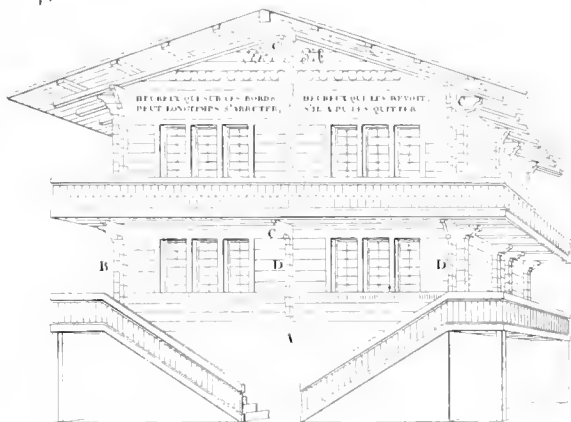


Fig. 4.

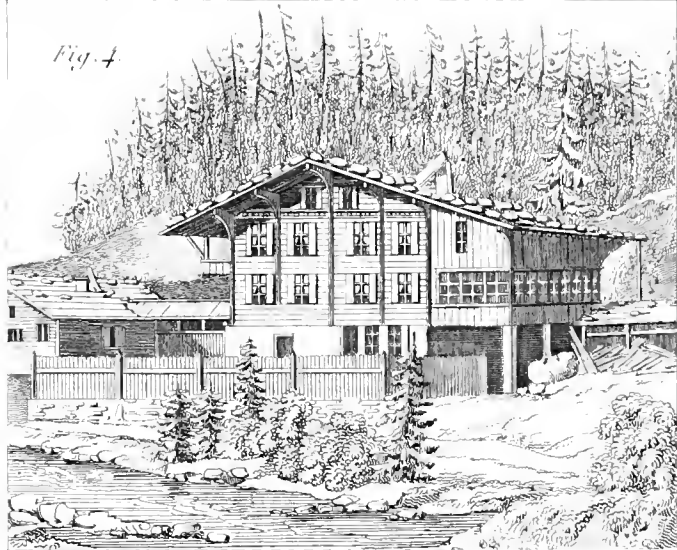
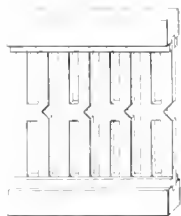


Fig. 3.



Détail d'une balustrade de bois.

Fig. 2.

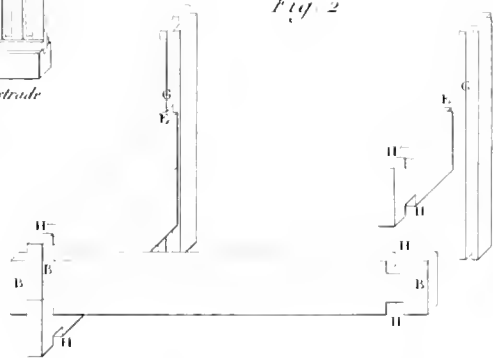


Fig. 5.

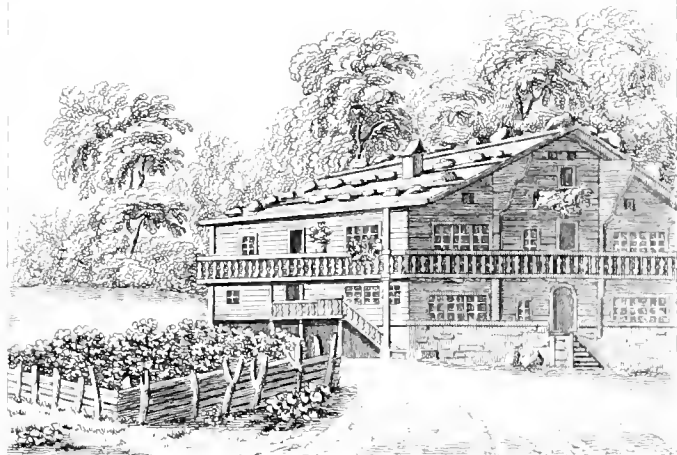




Fig. 2.

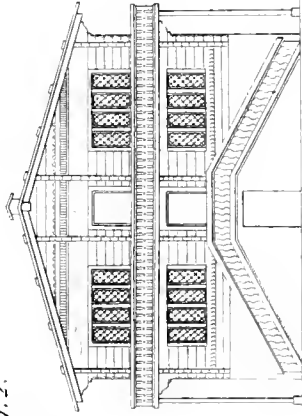
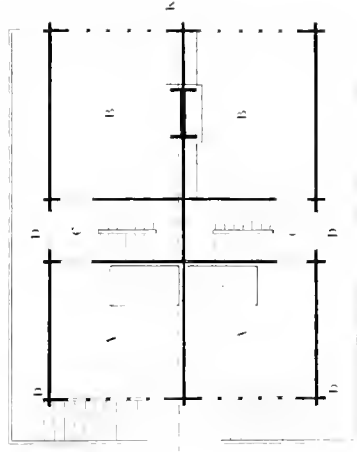
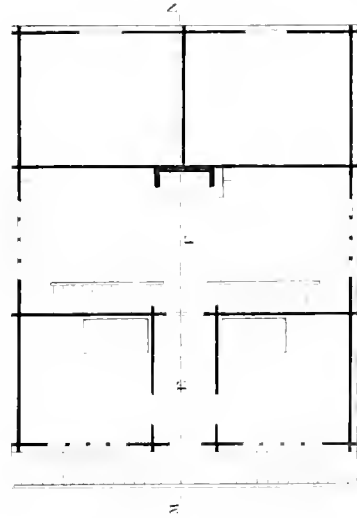
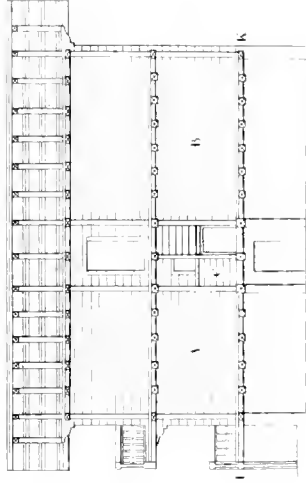
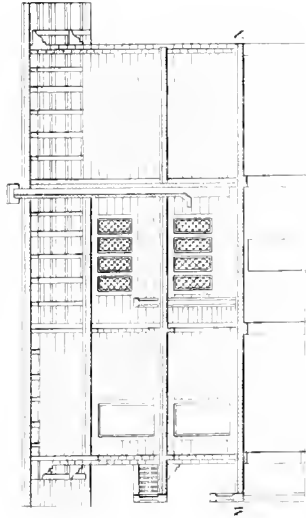
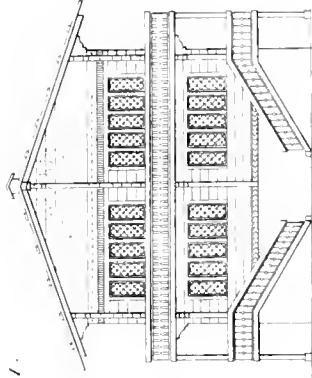
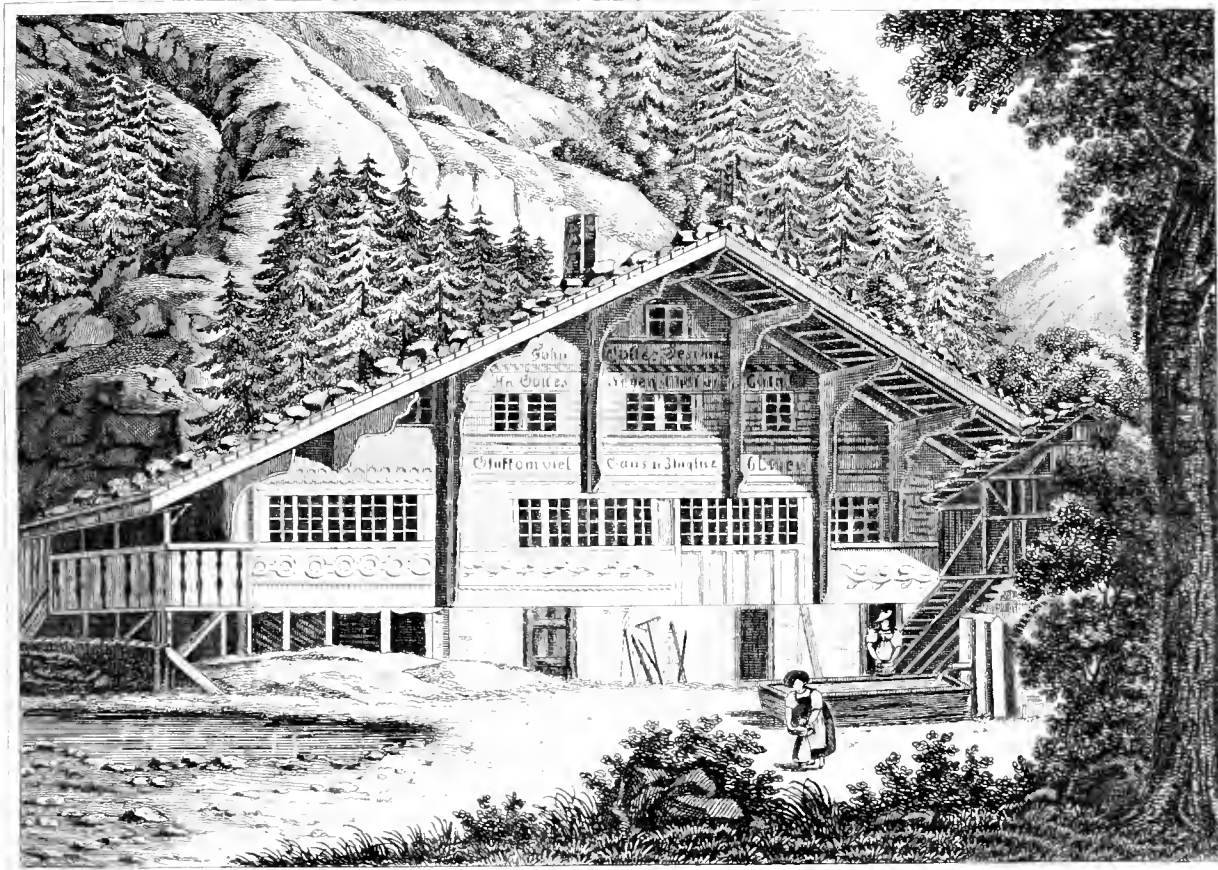


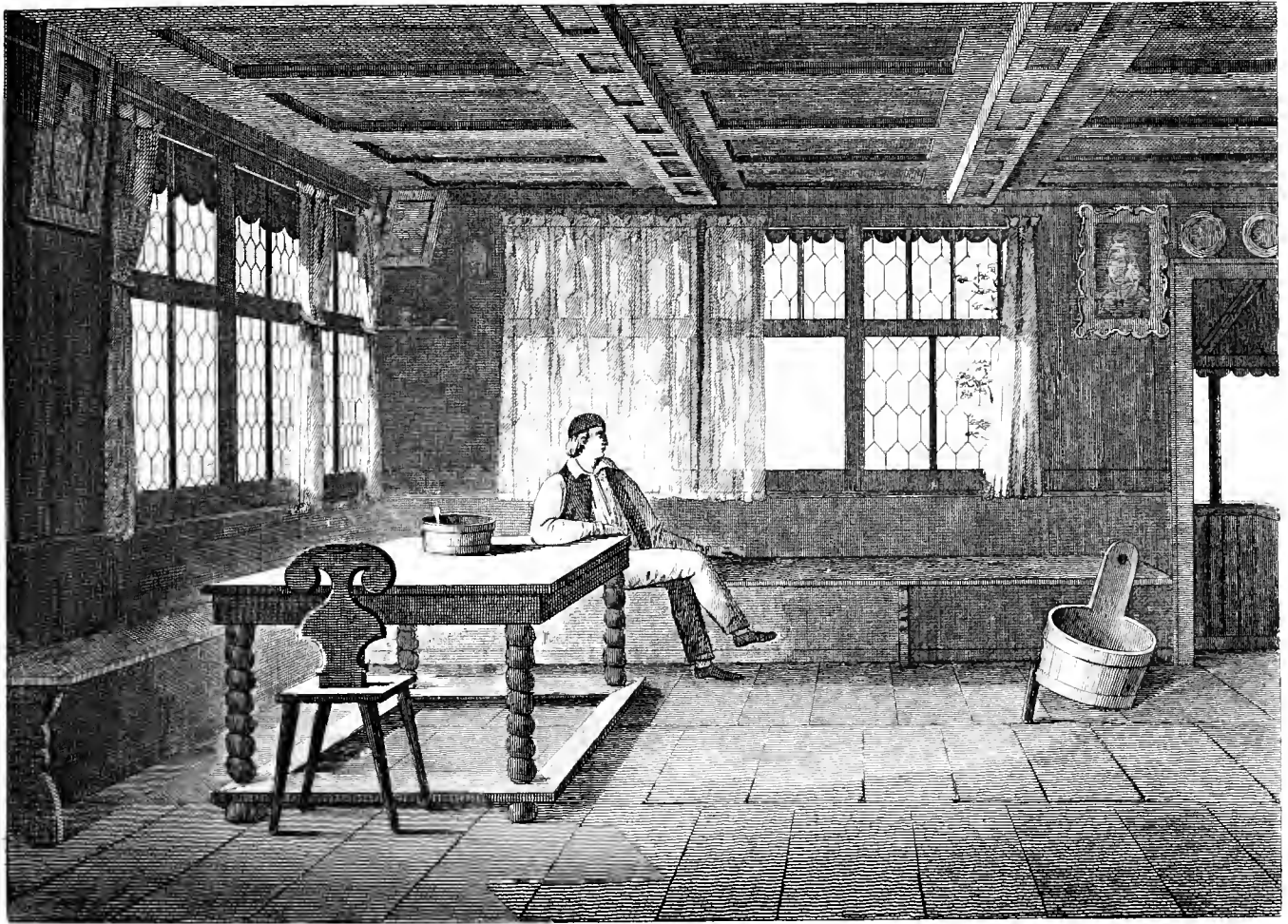
Fig. 1.





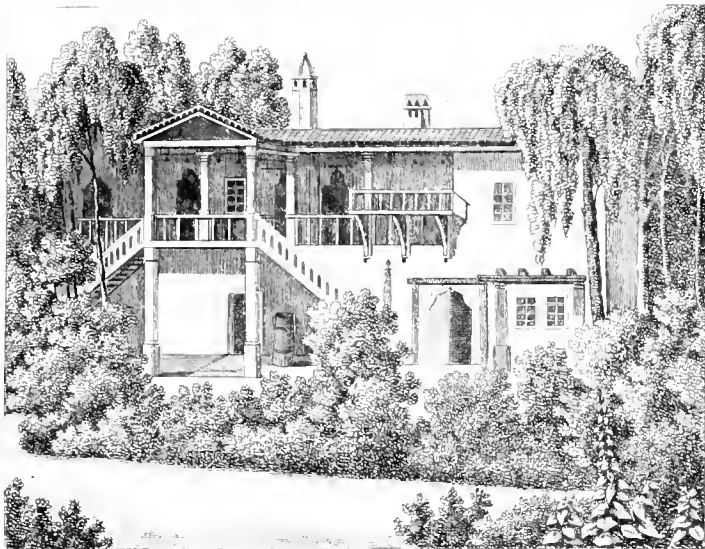




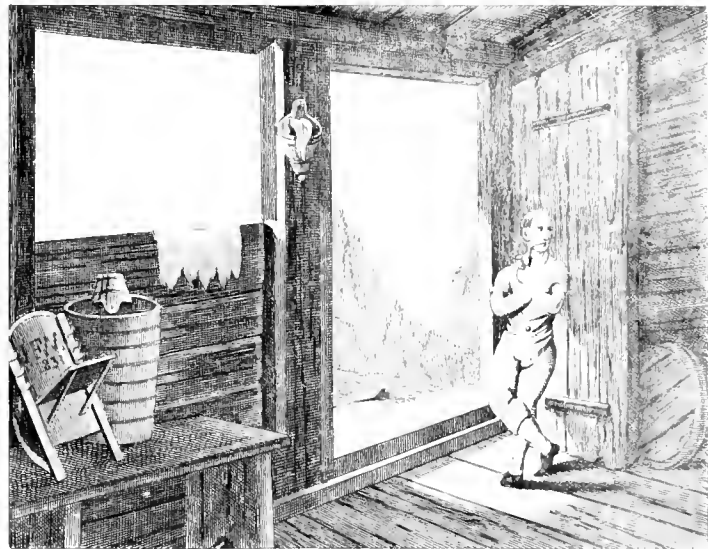


Intérieur d'une maison suisse.





3 MAISON DANS UN BOSQUET



4 INTÉRIEUR D'UN CHALET



Caricature del

CHAUMIÈRES RUSSSES, AL RAÏNÏ

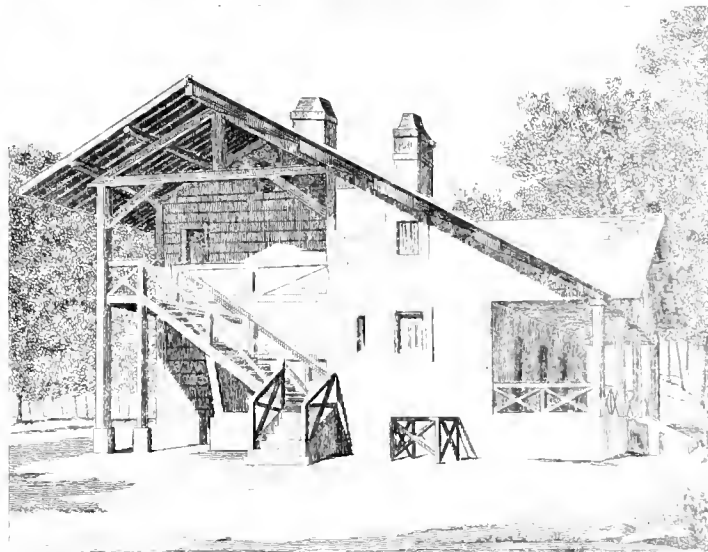
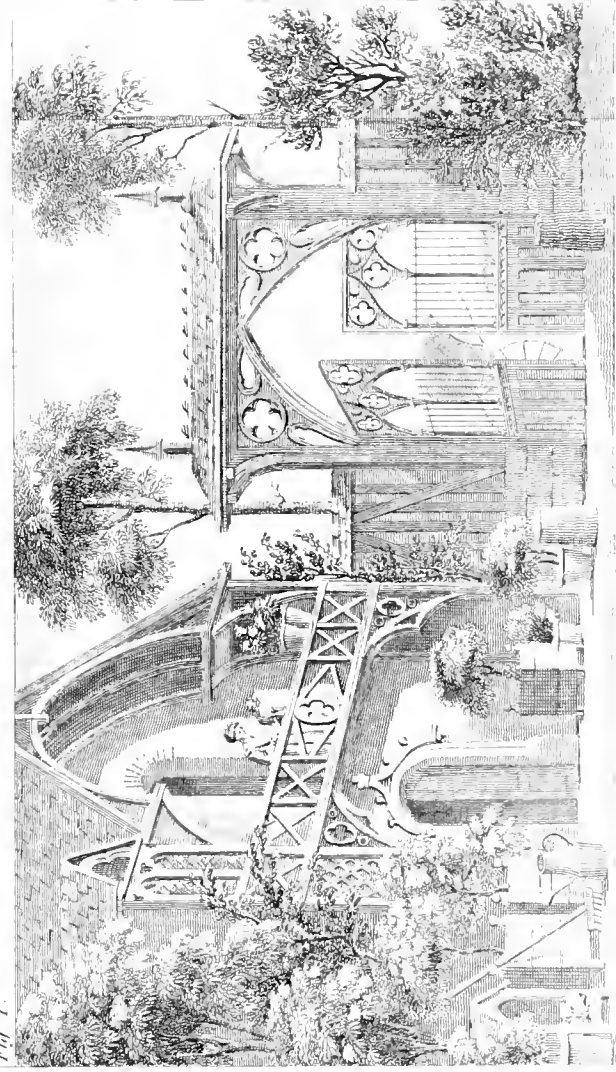


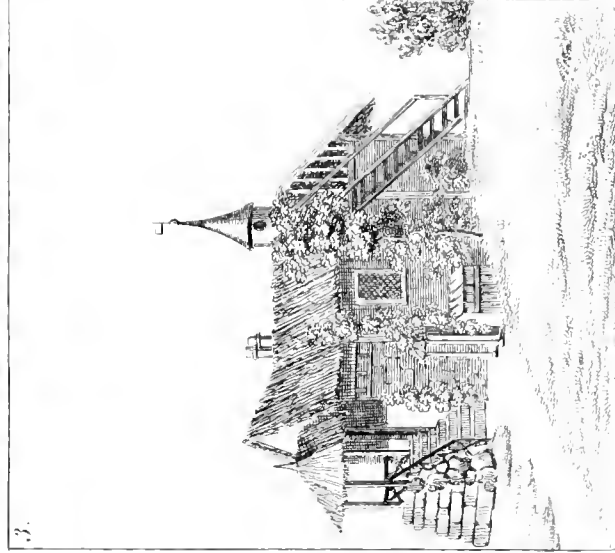
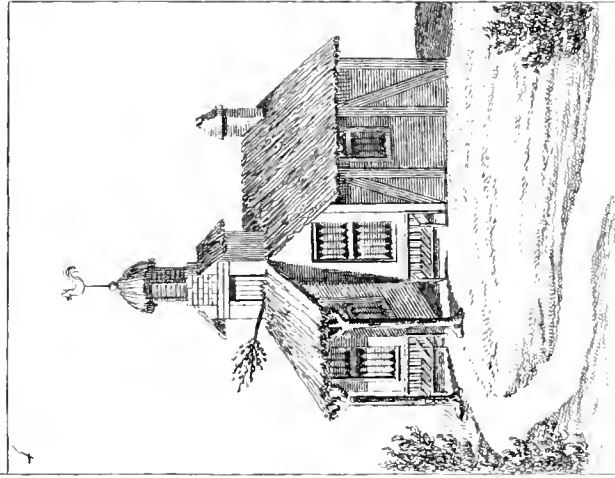
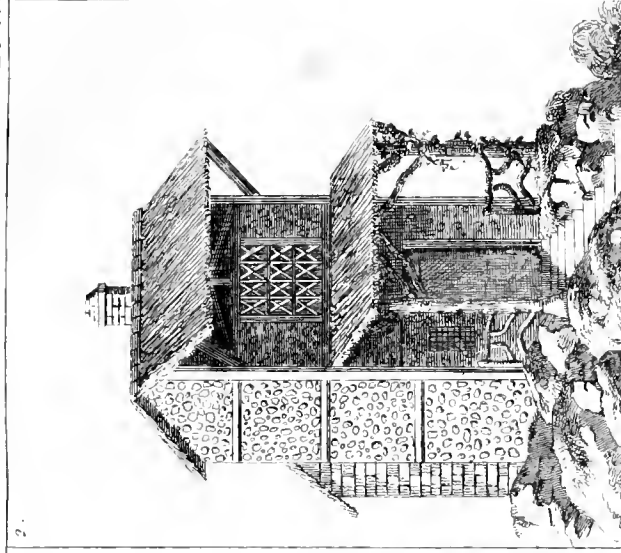
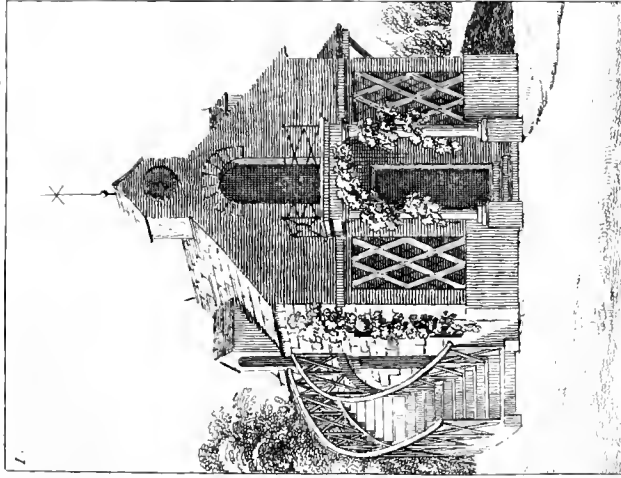




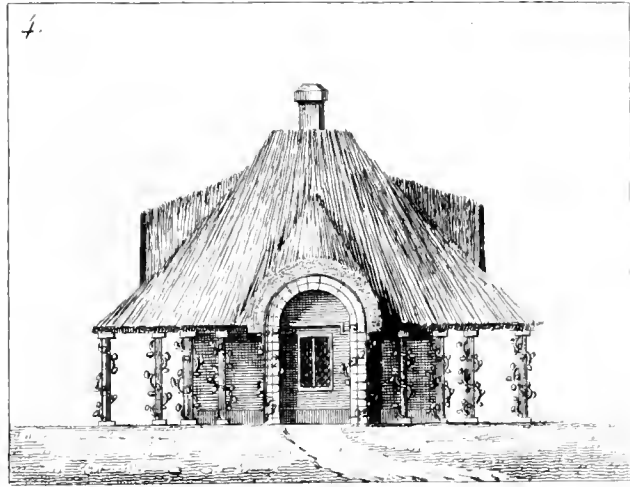
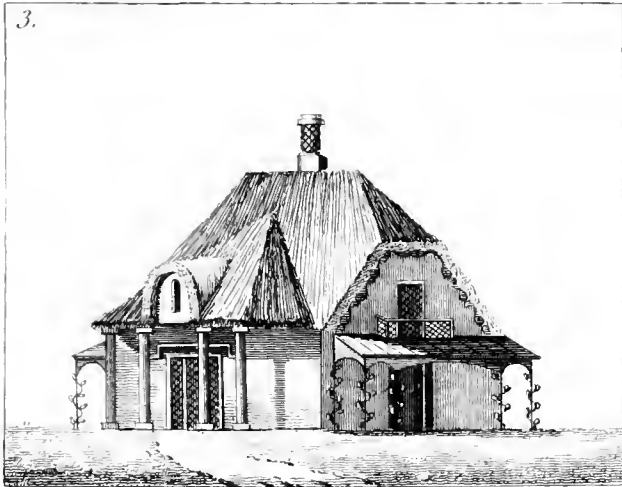
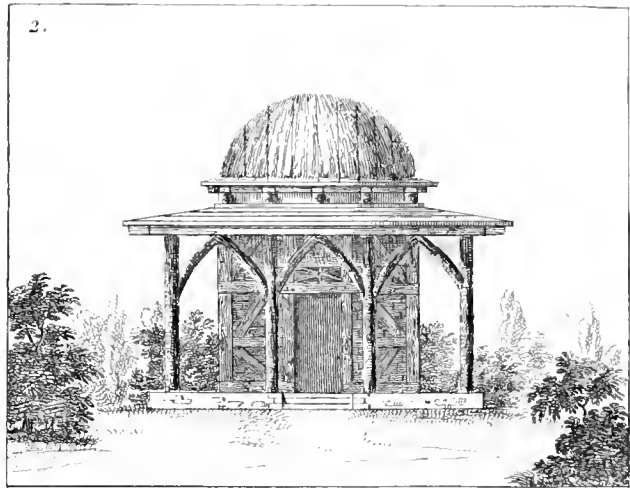
Fig. 1.



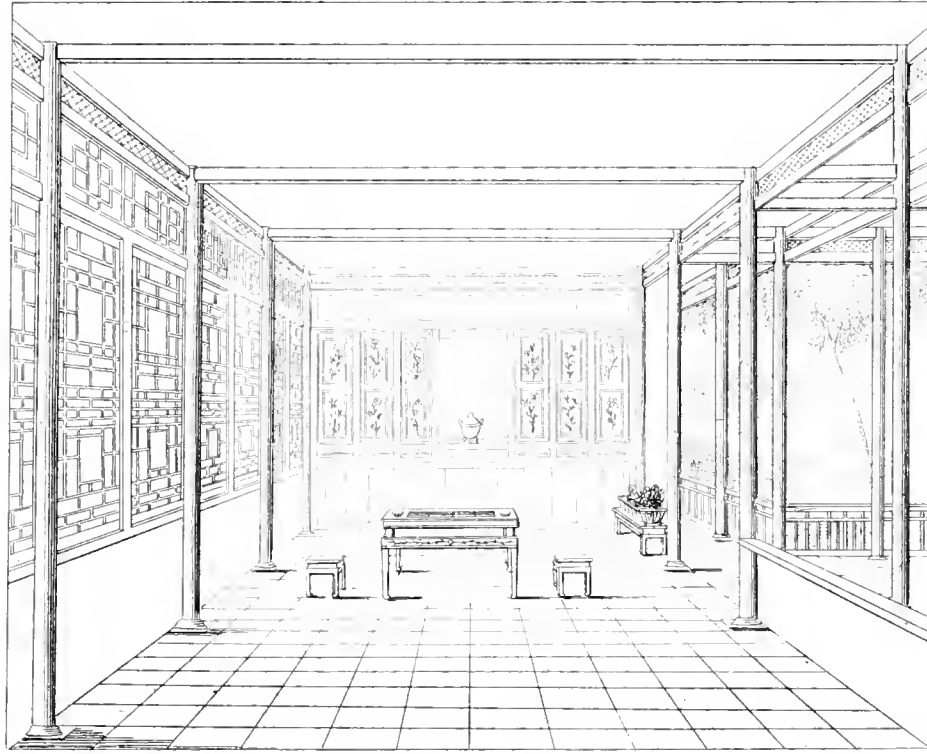
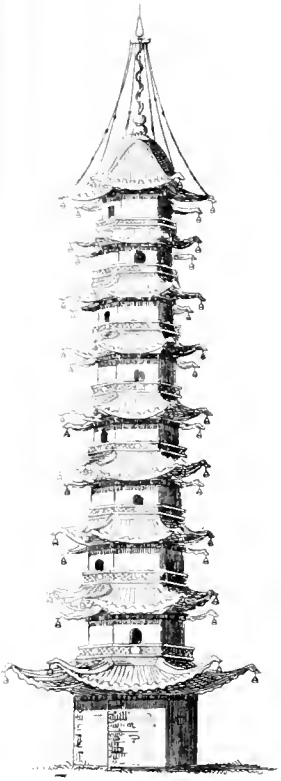
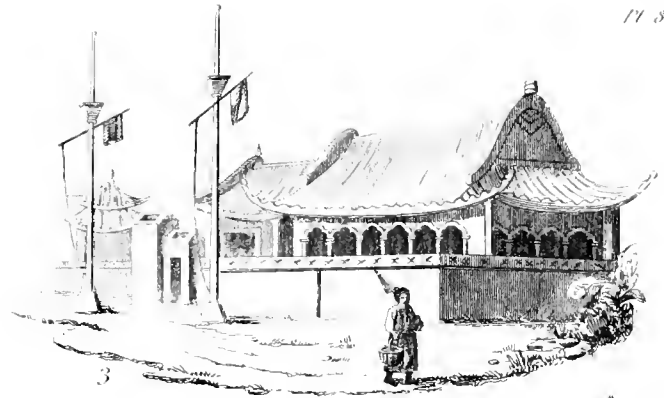
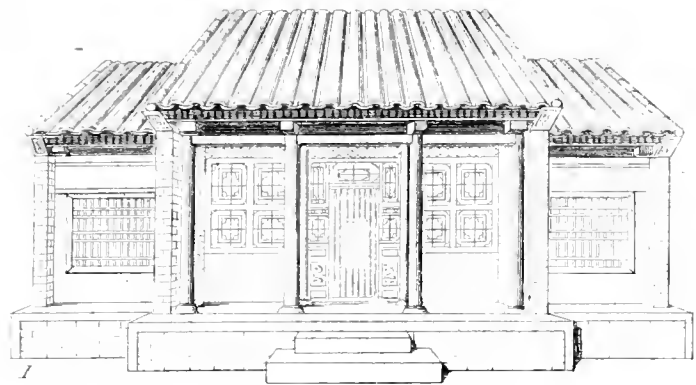








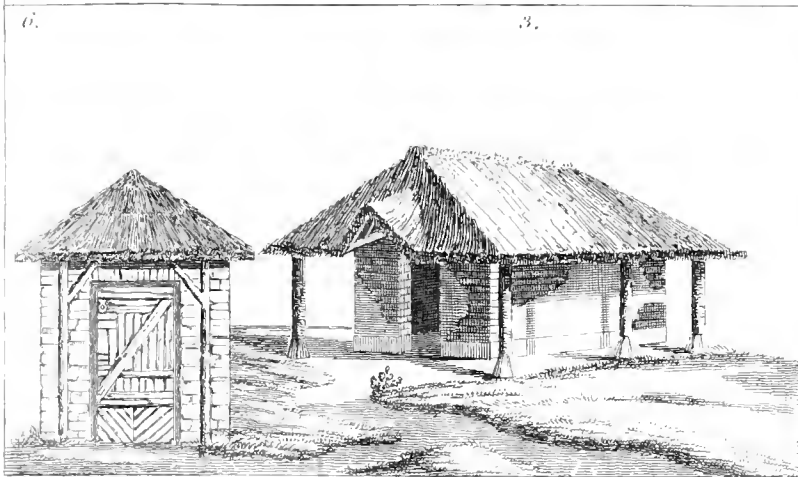
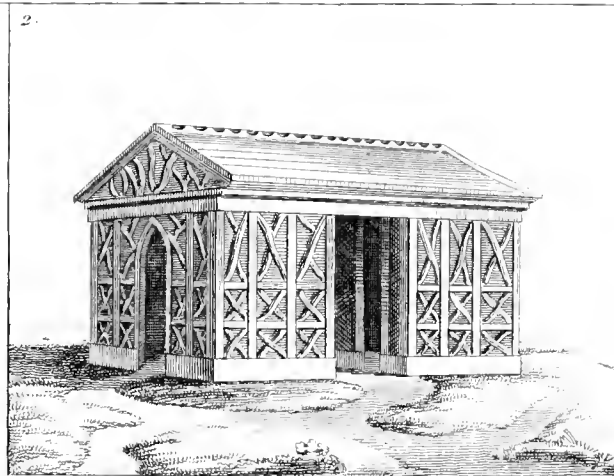
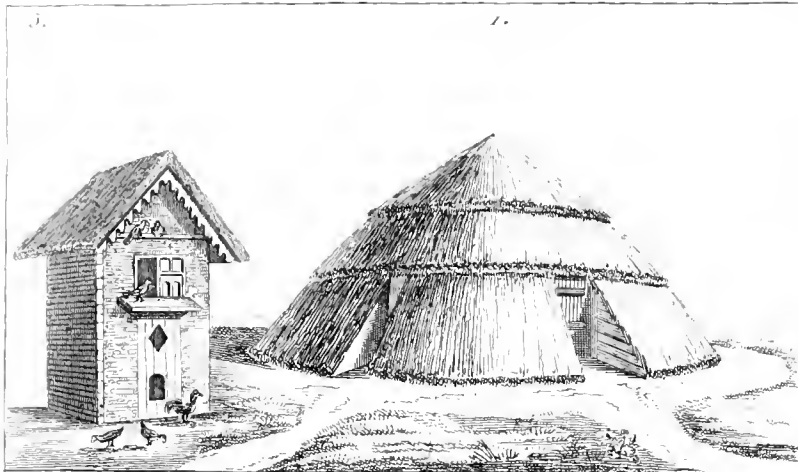




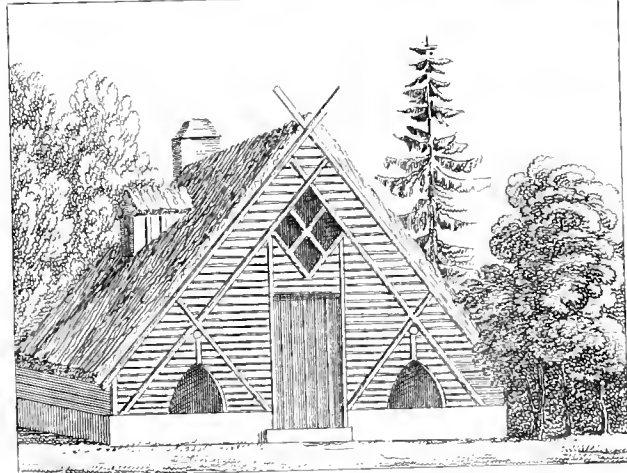
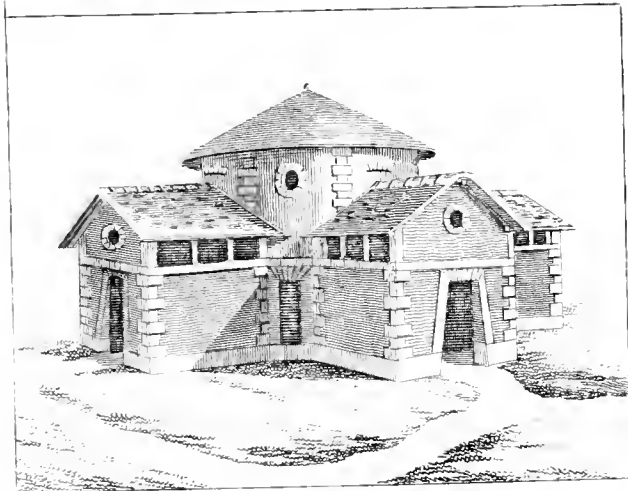
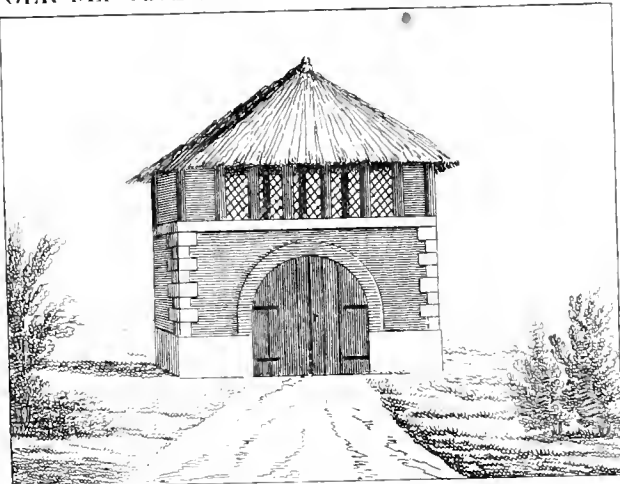
HABITATIONS ET MONUMENTS CHINOIS

Turin, sc

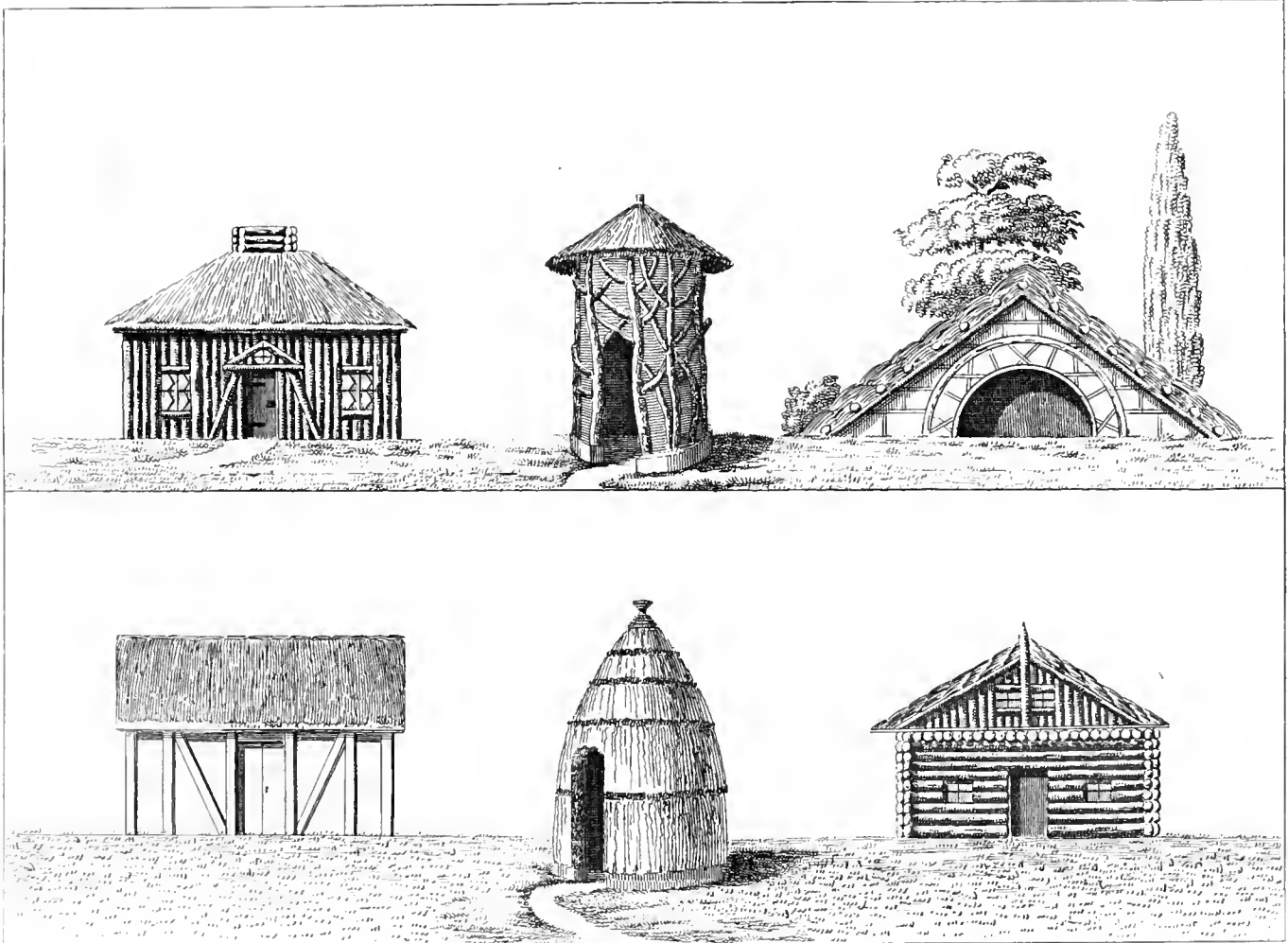




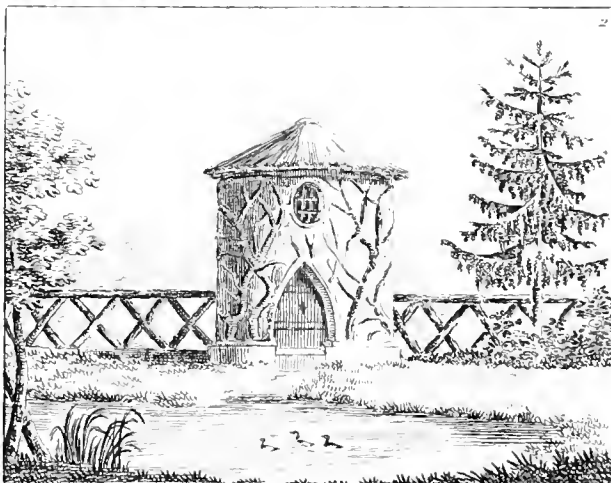
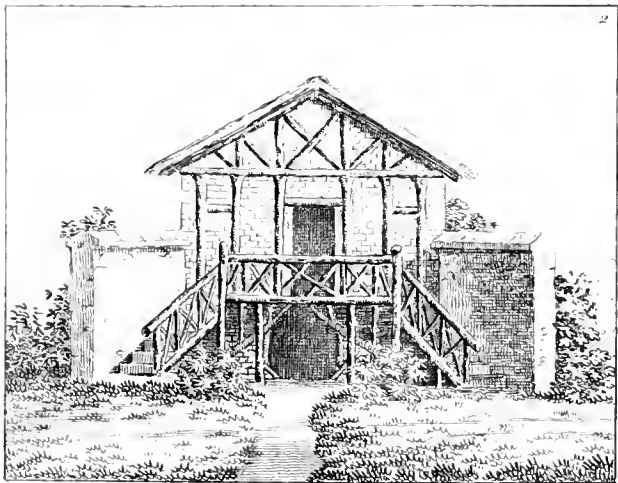
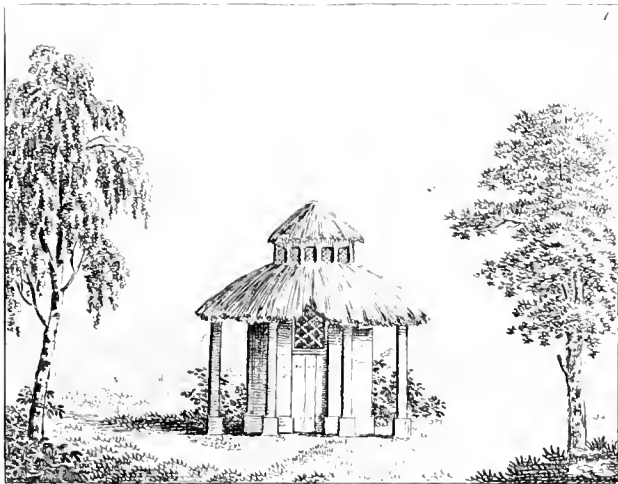






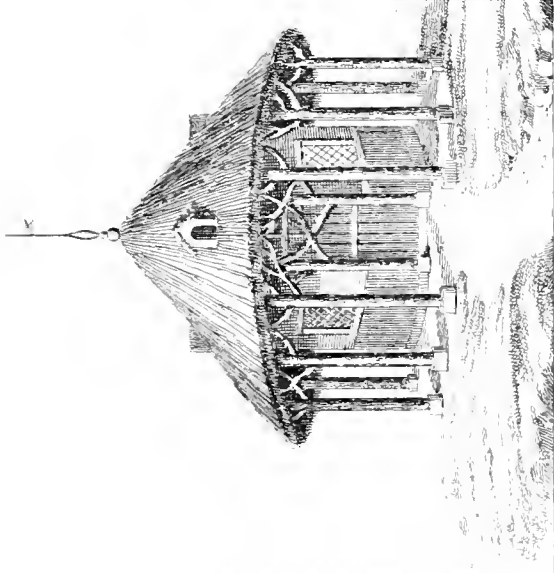




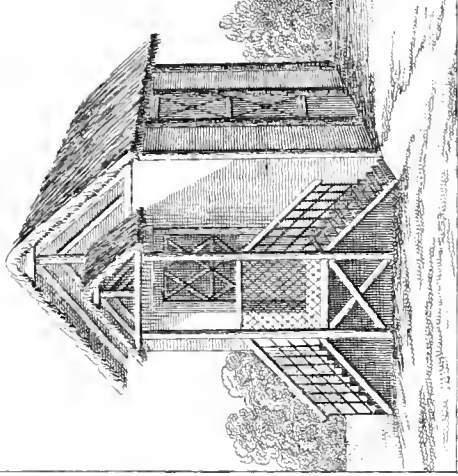




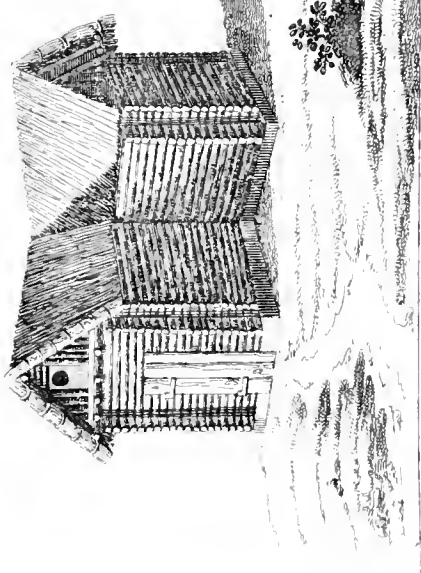
1.



2.



3.



4.

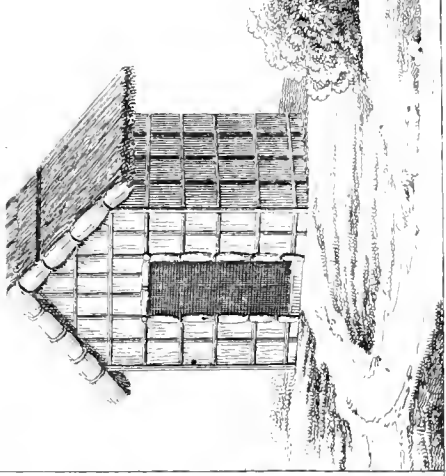
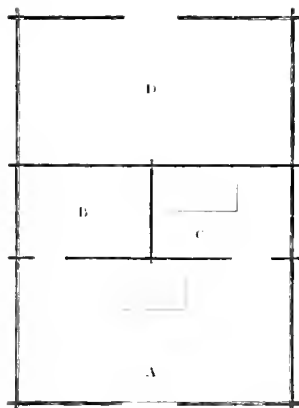
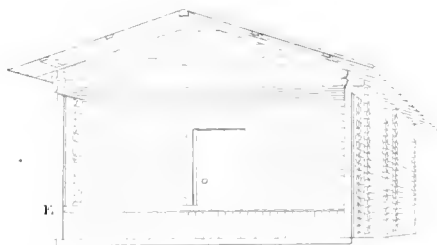
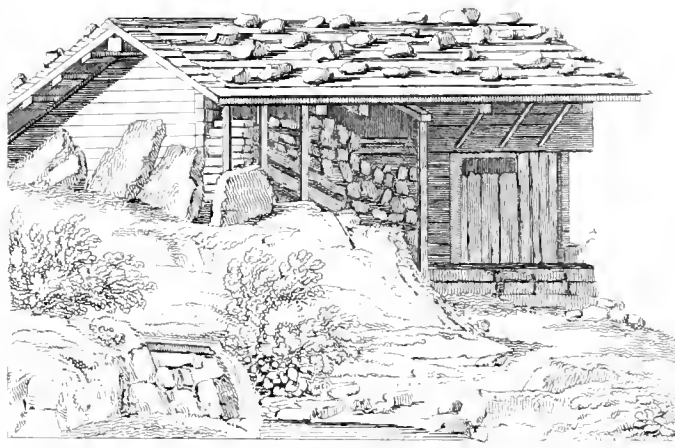
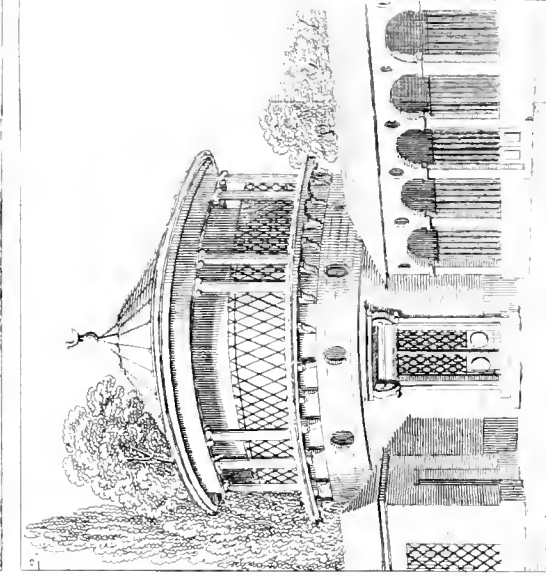
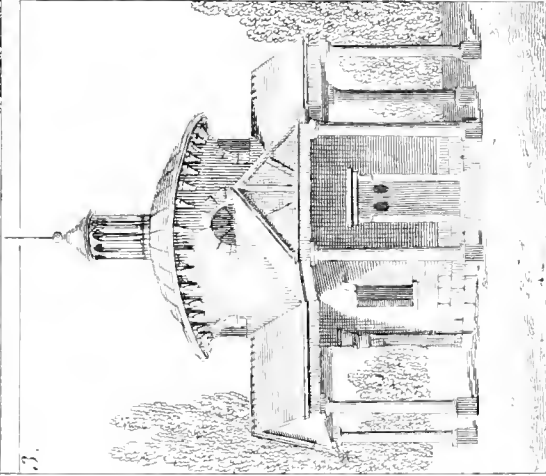
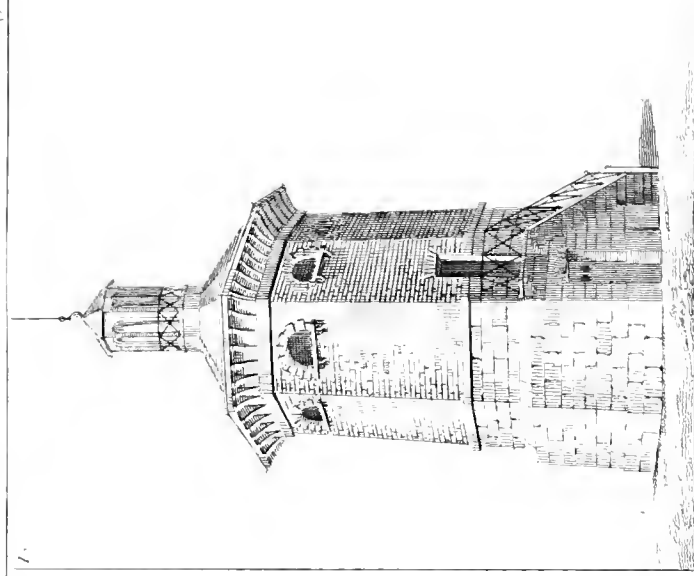
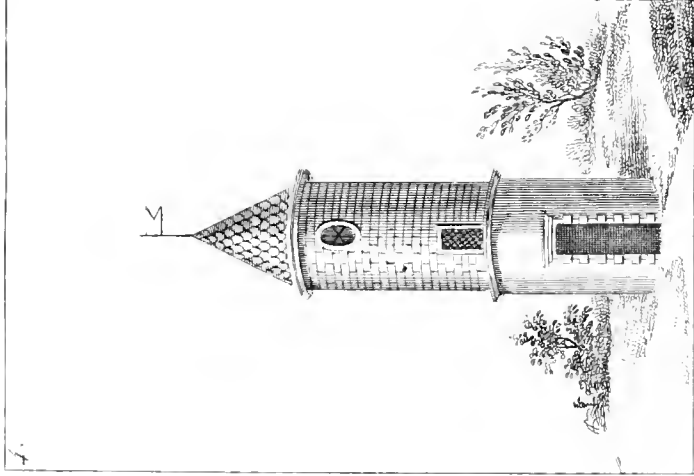




Fig. 1.*Fig. 2.**Fig. 3.*



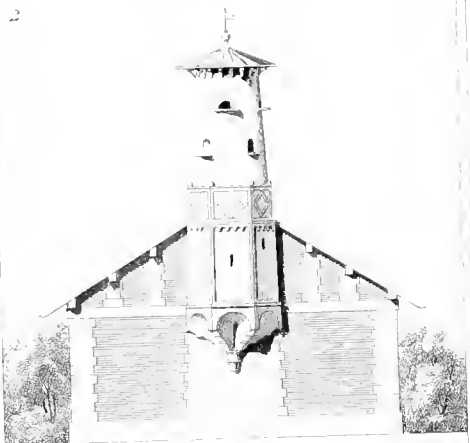






Plan, fig 3

2



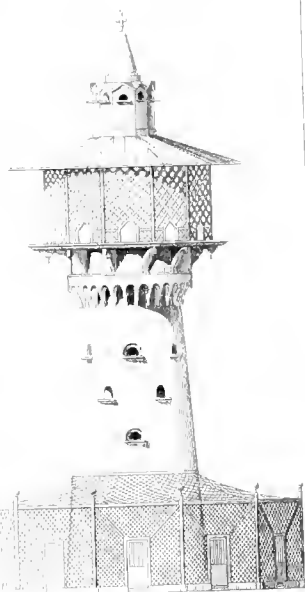
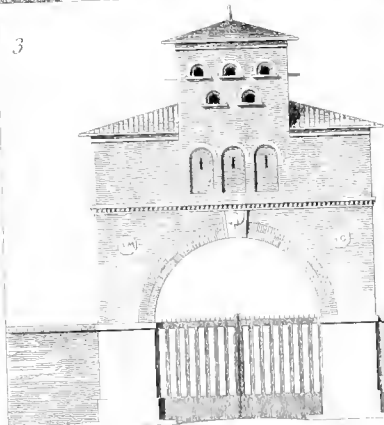
Plan, fig 4

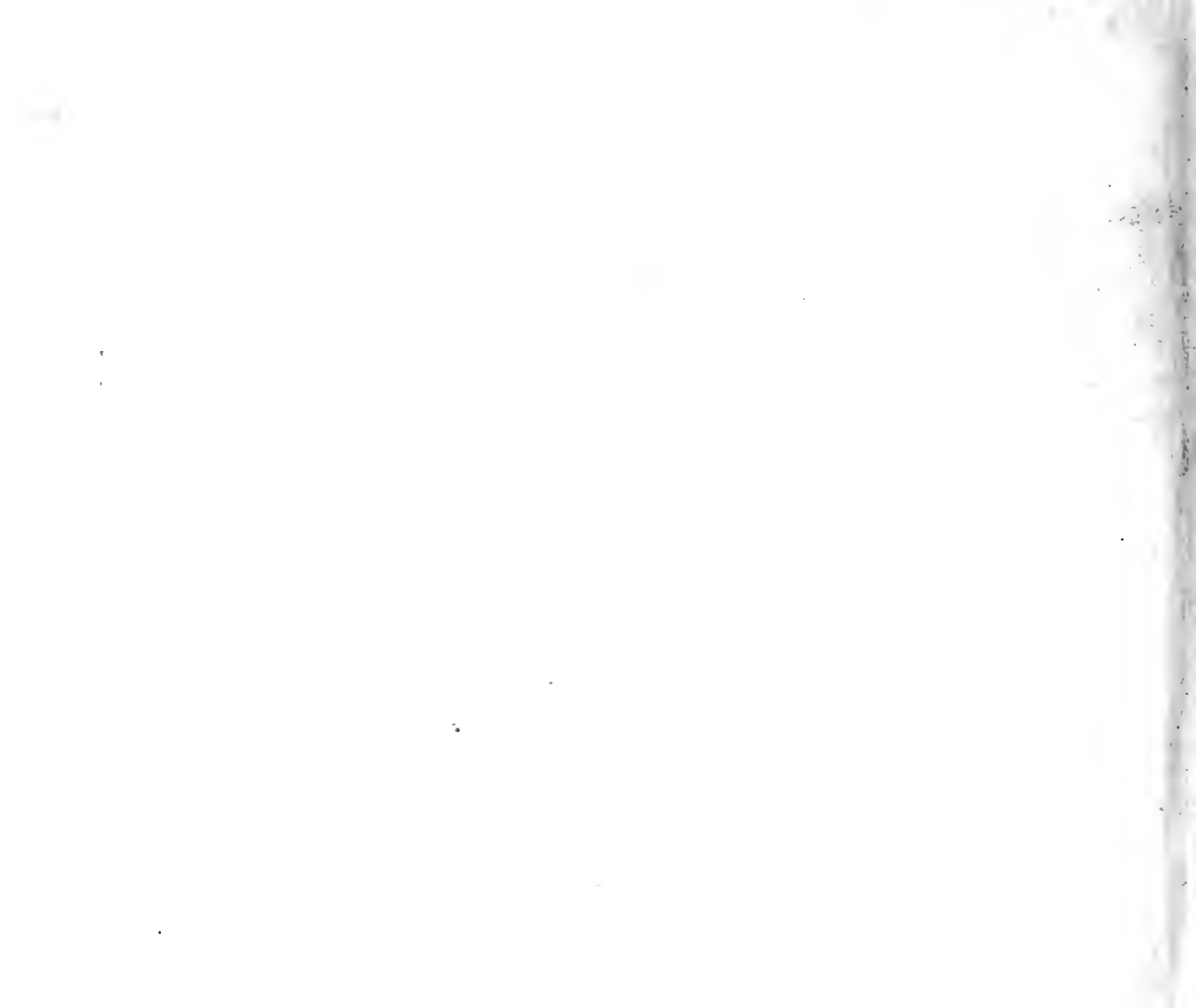
1

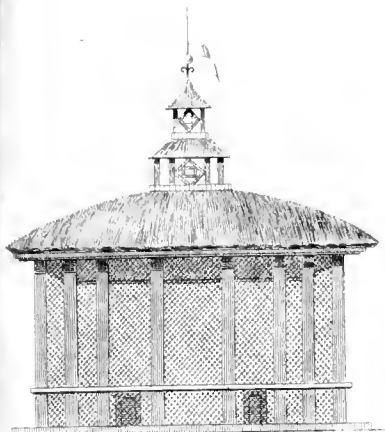


4

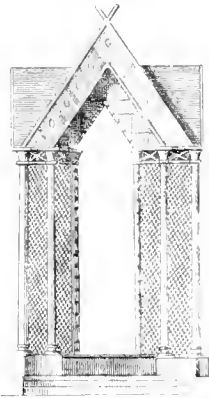
3



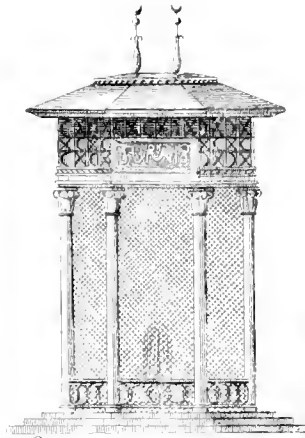




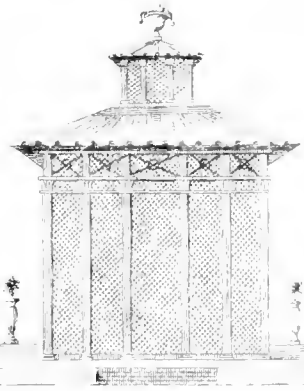
1



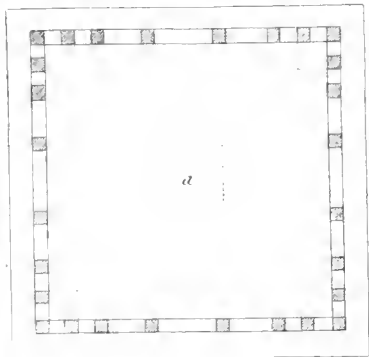
2



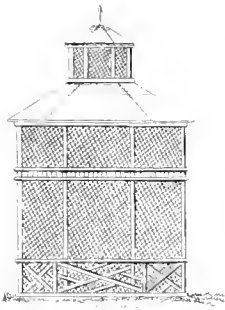
3



4



a



5



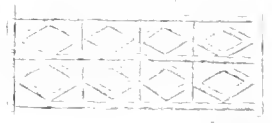
Plan



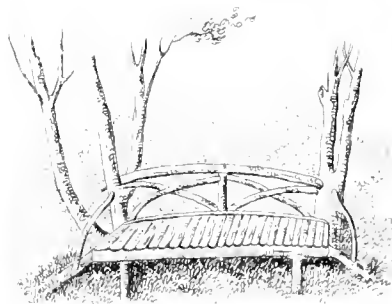
6



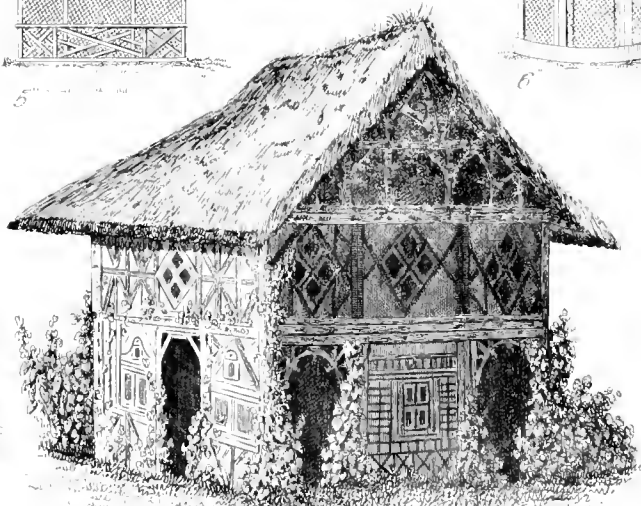
8



10



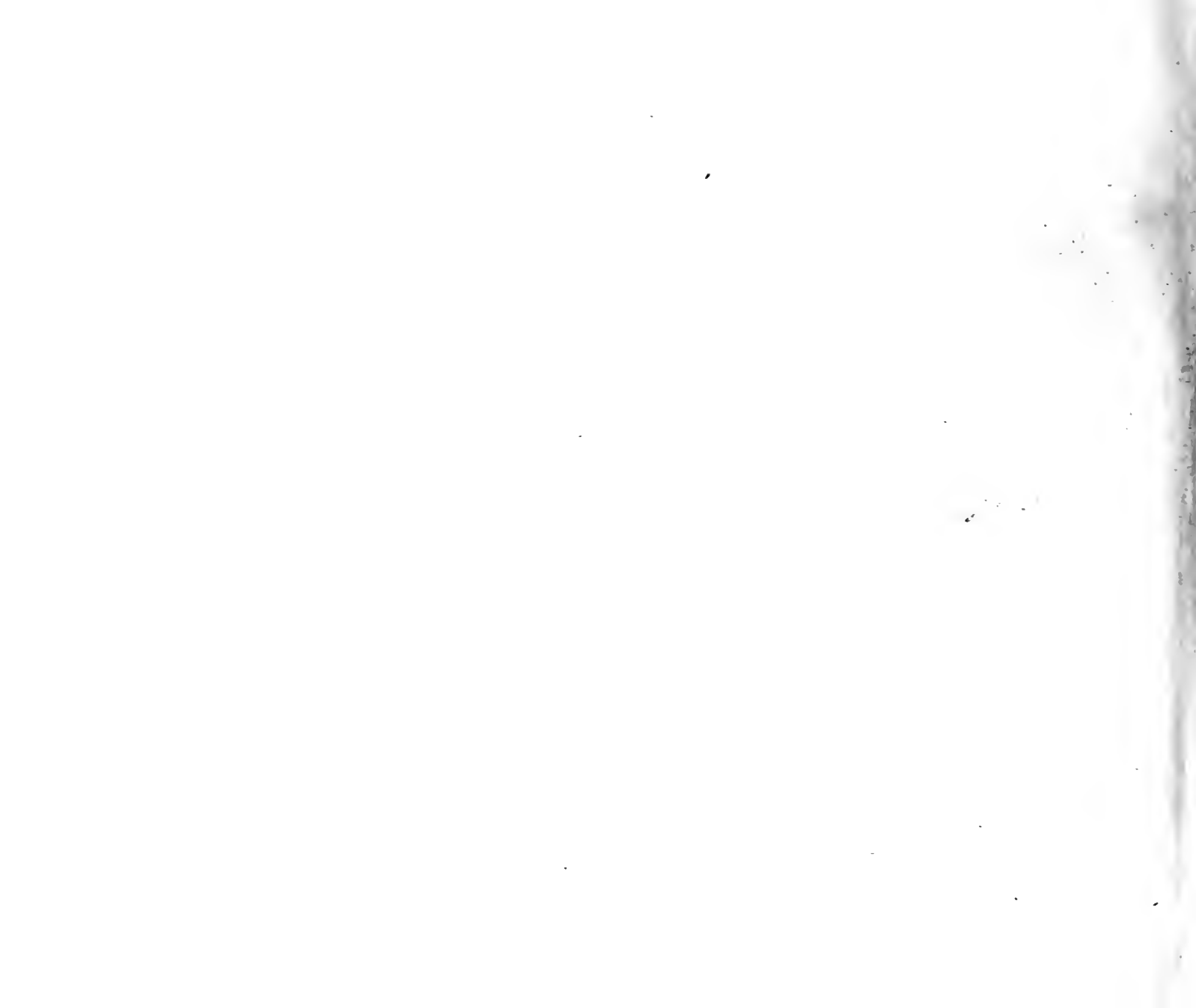
11

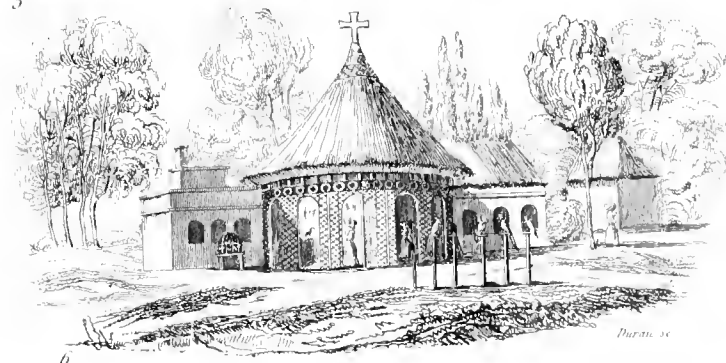
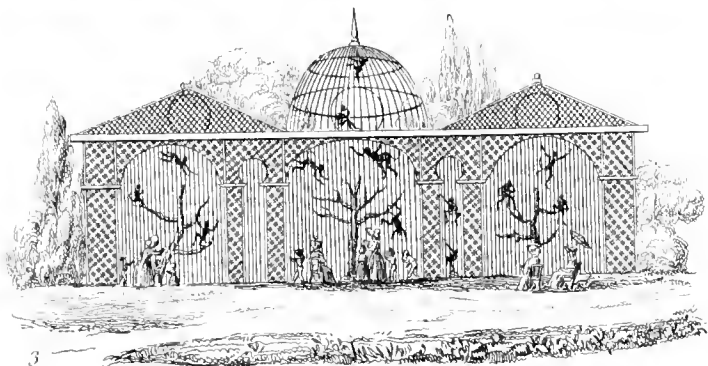
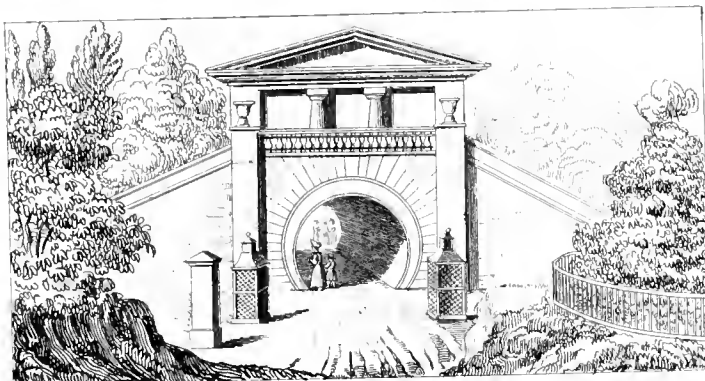
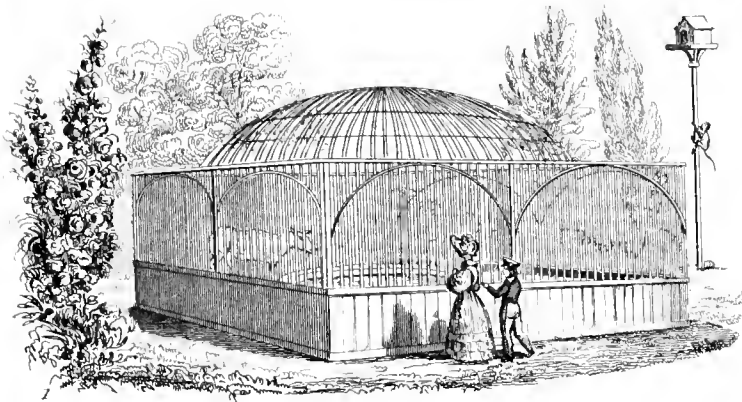


9



10



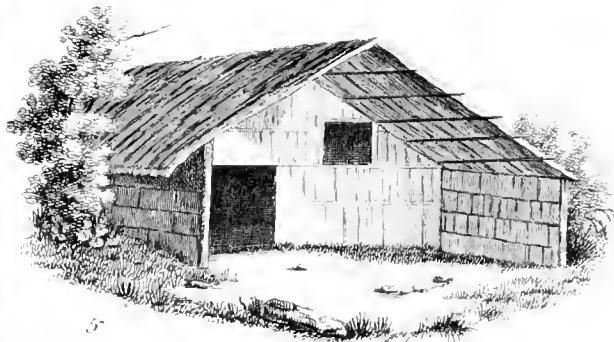
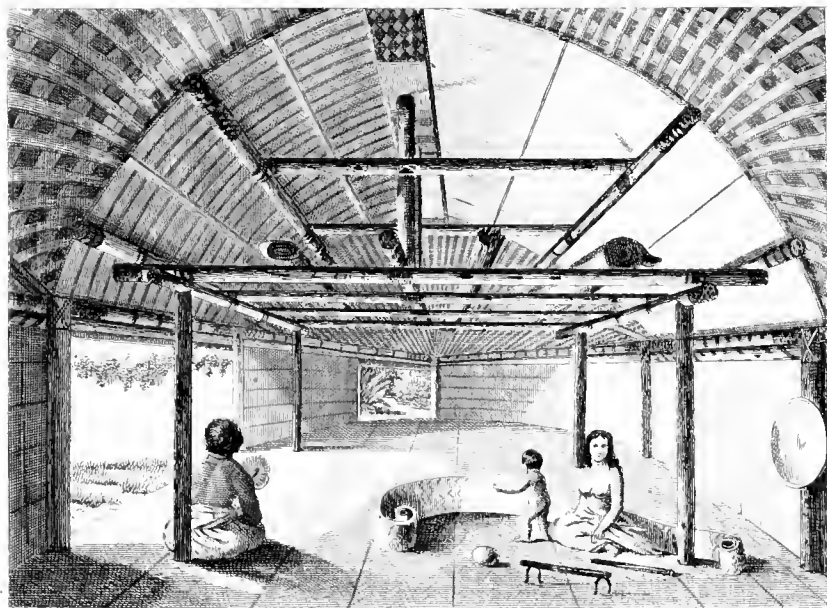
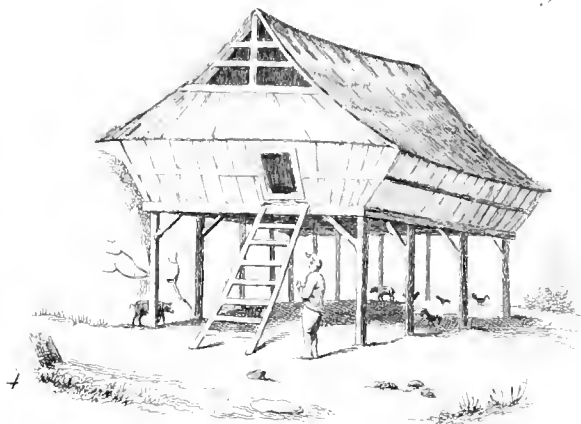
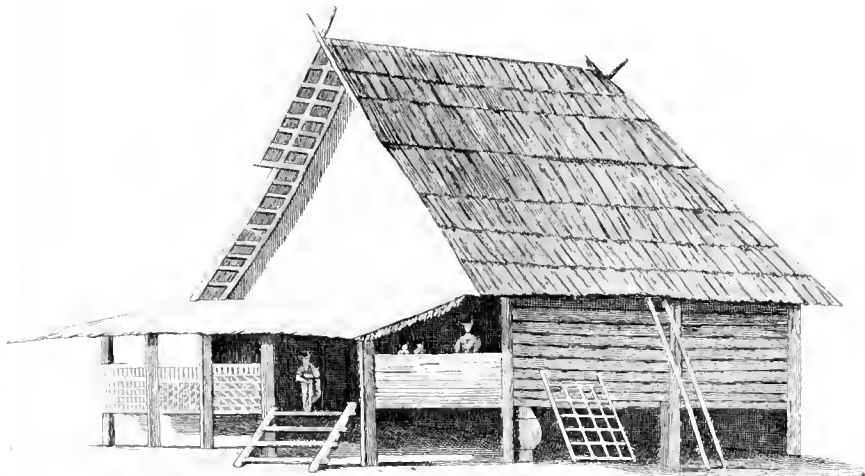


3

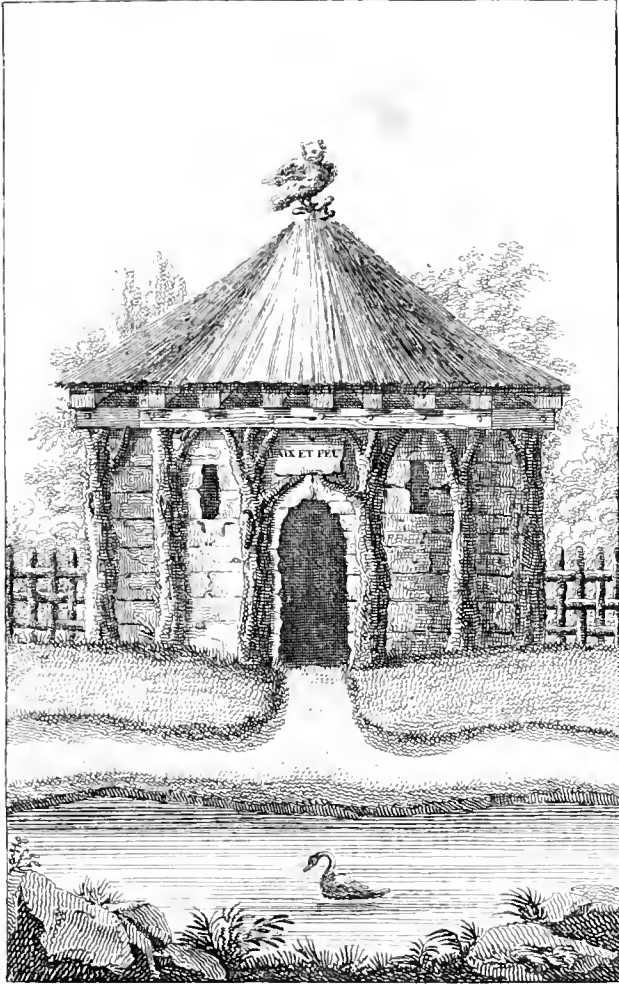
6

Duran sc

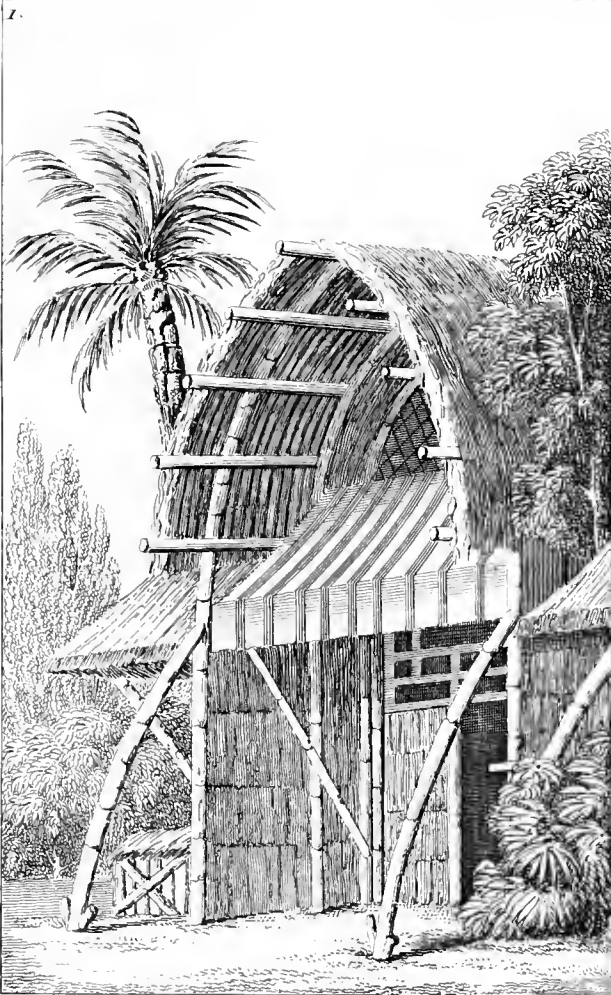




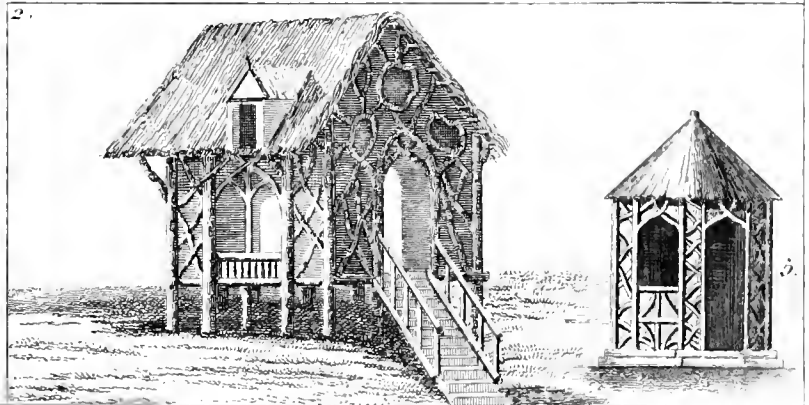
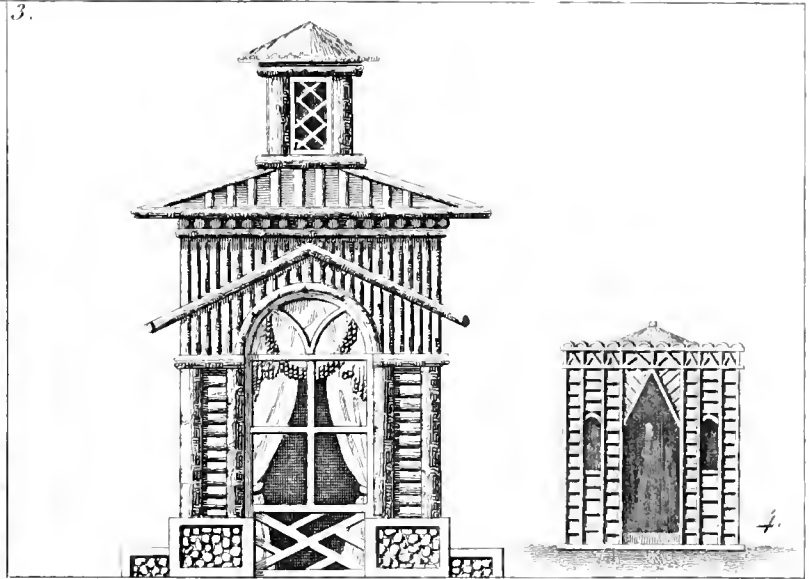




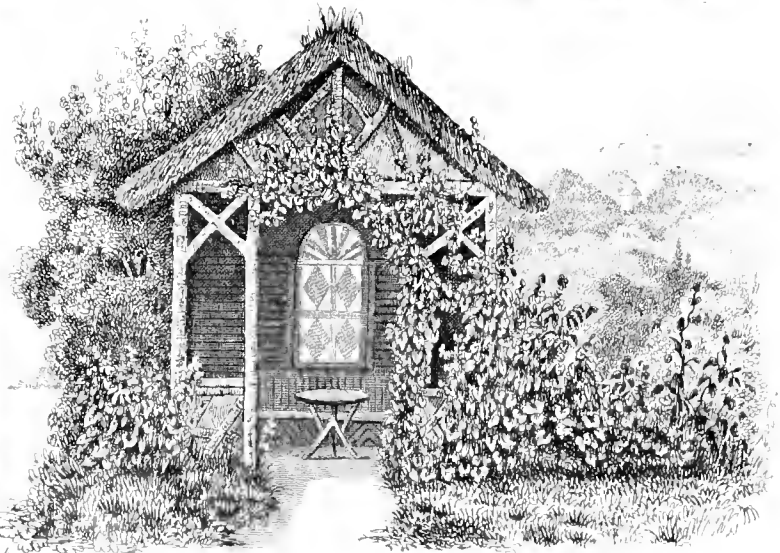
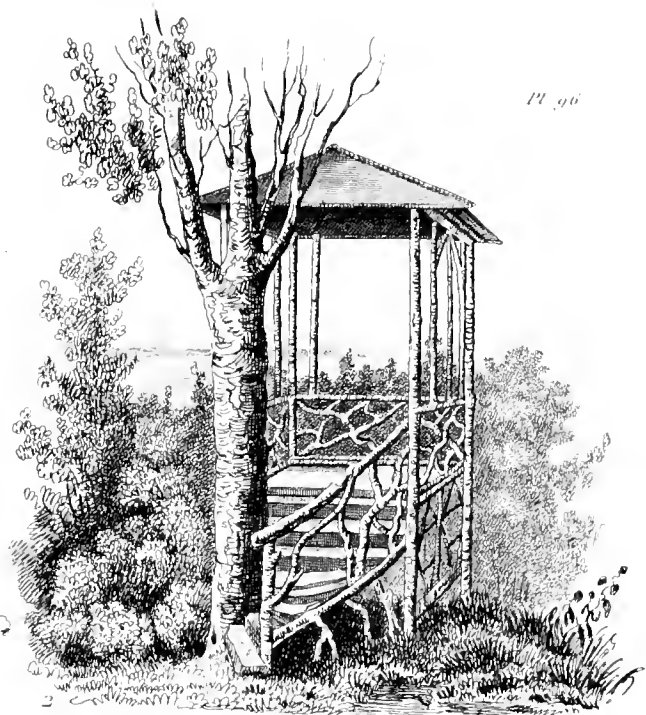




Chaumière Indienne.

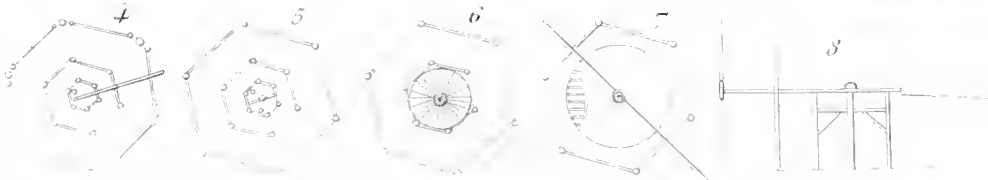
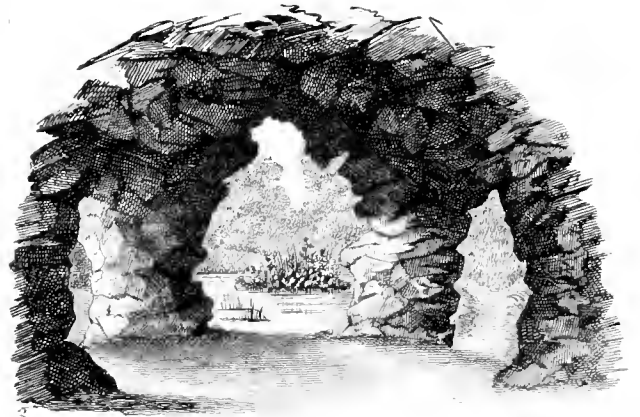
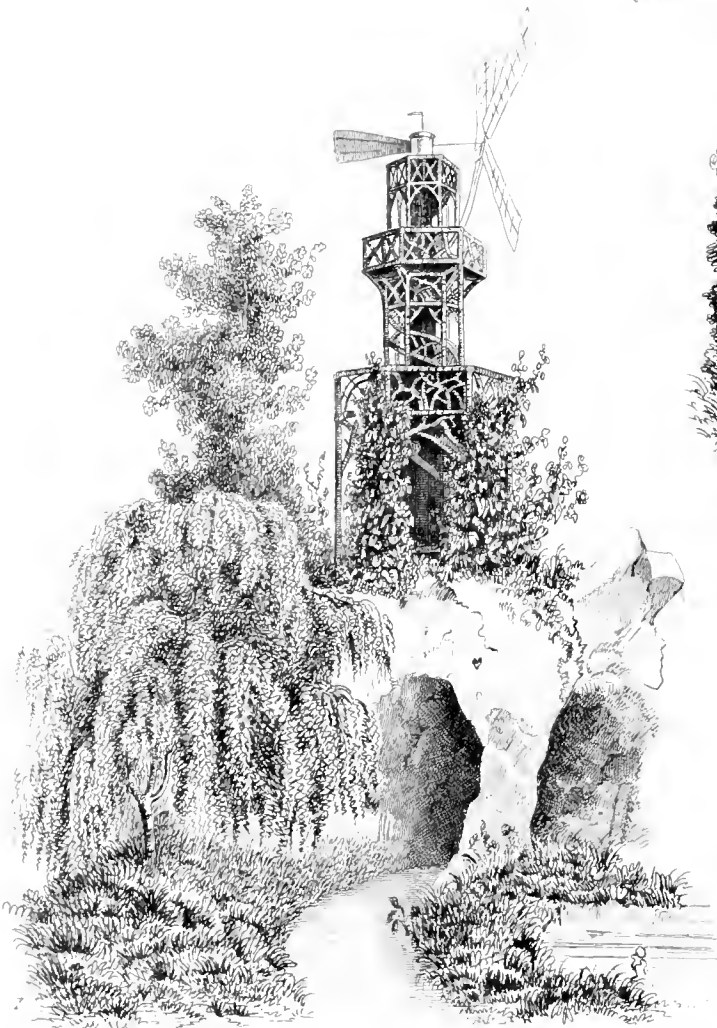




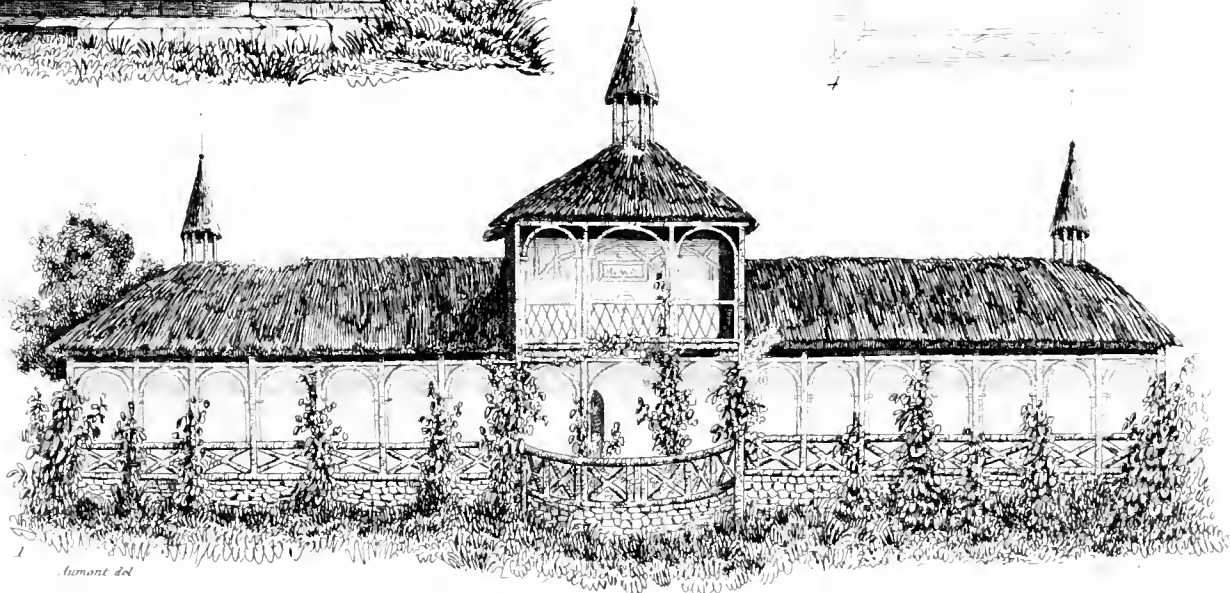
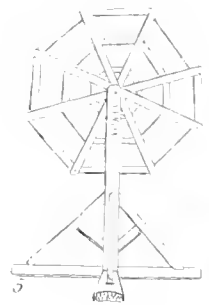
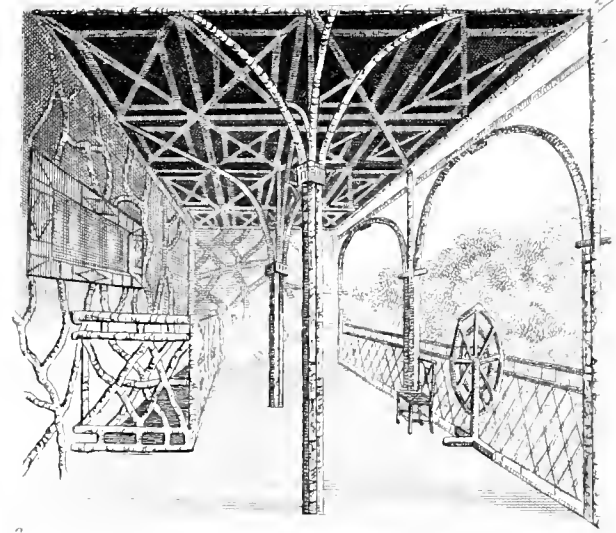
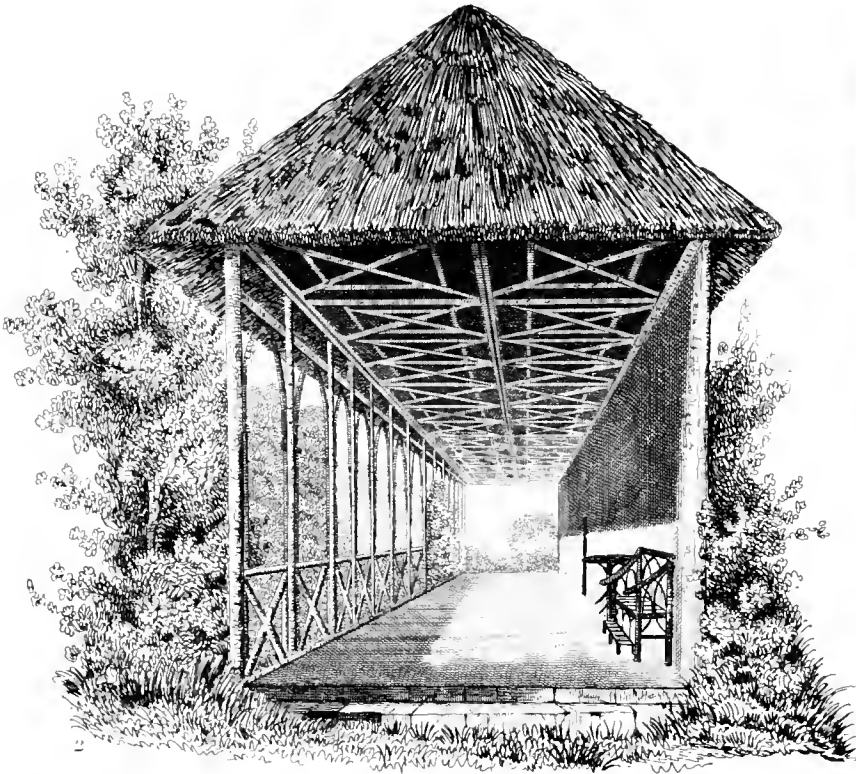


J. M. 1818



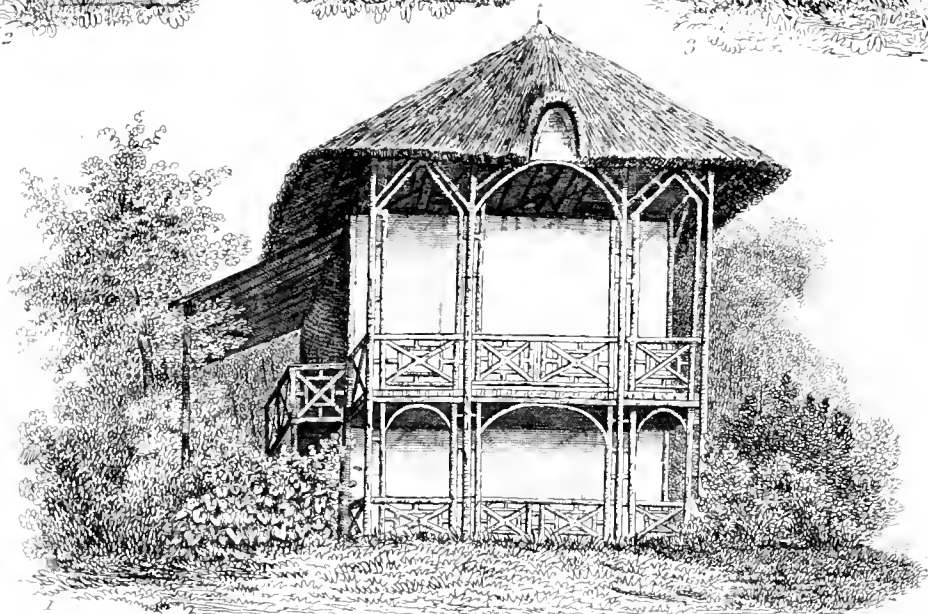
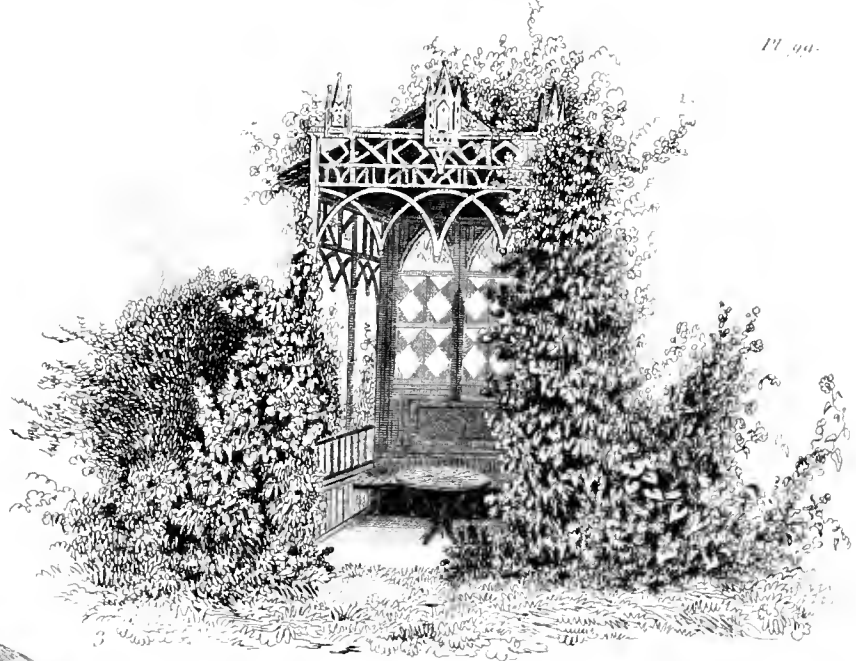
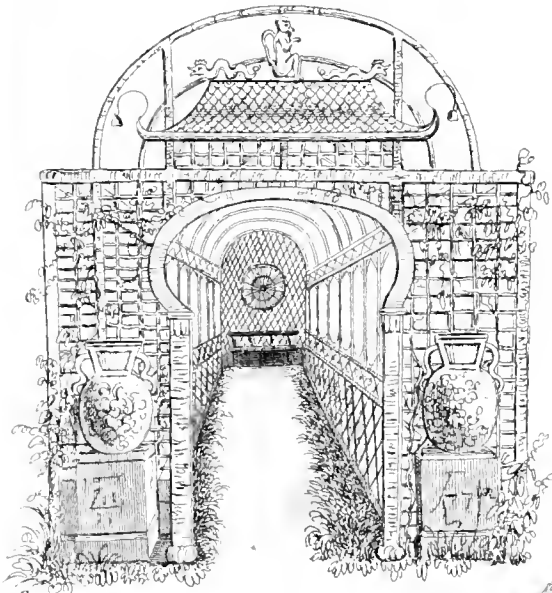






1
Lumont del



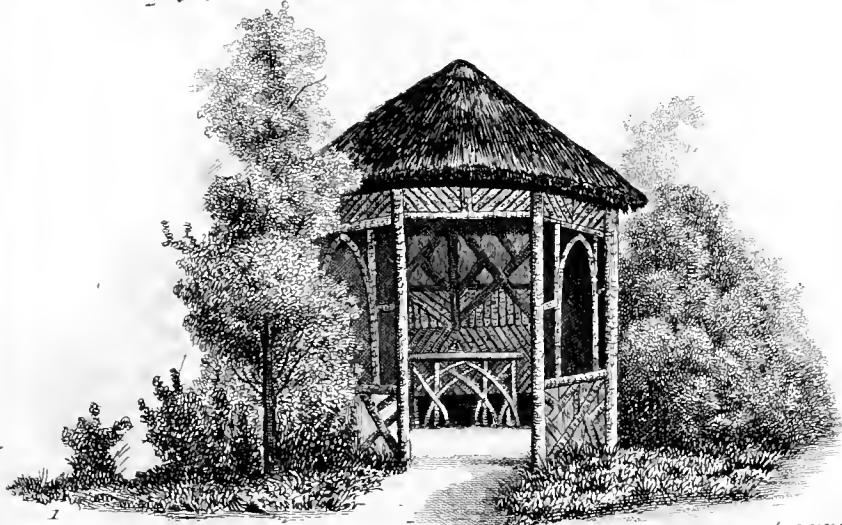
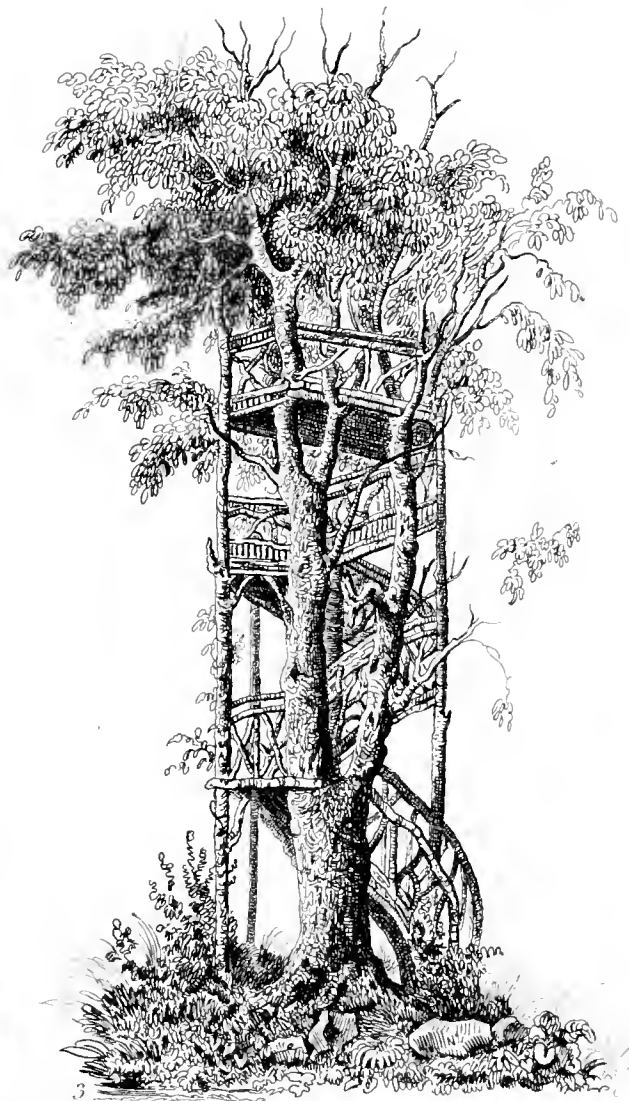
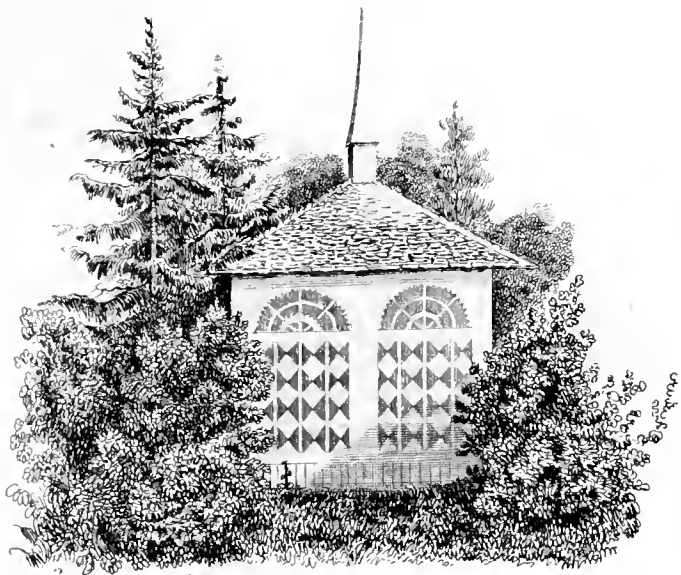


Amant del



FABRIQUES D'ORNEMENT.

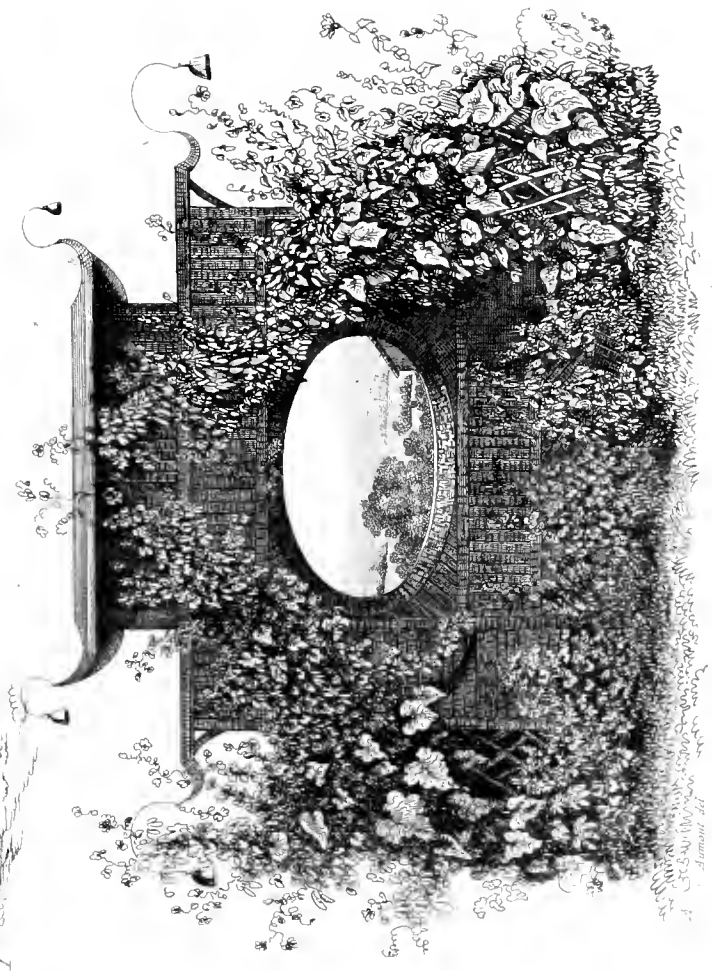




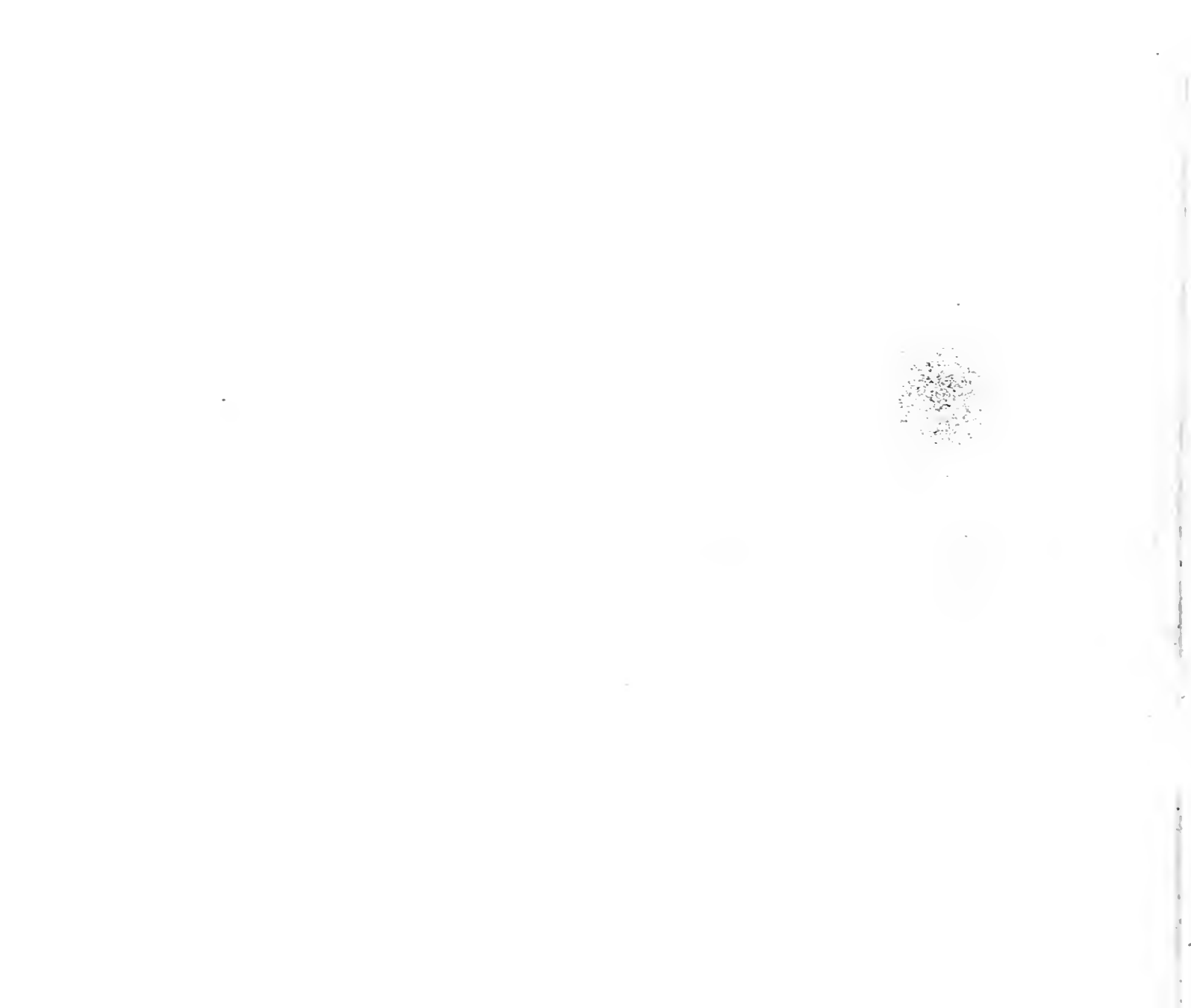
Aumont del.

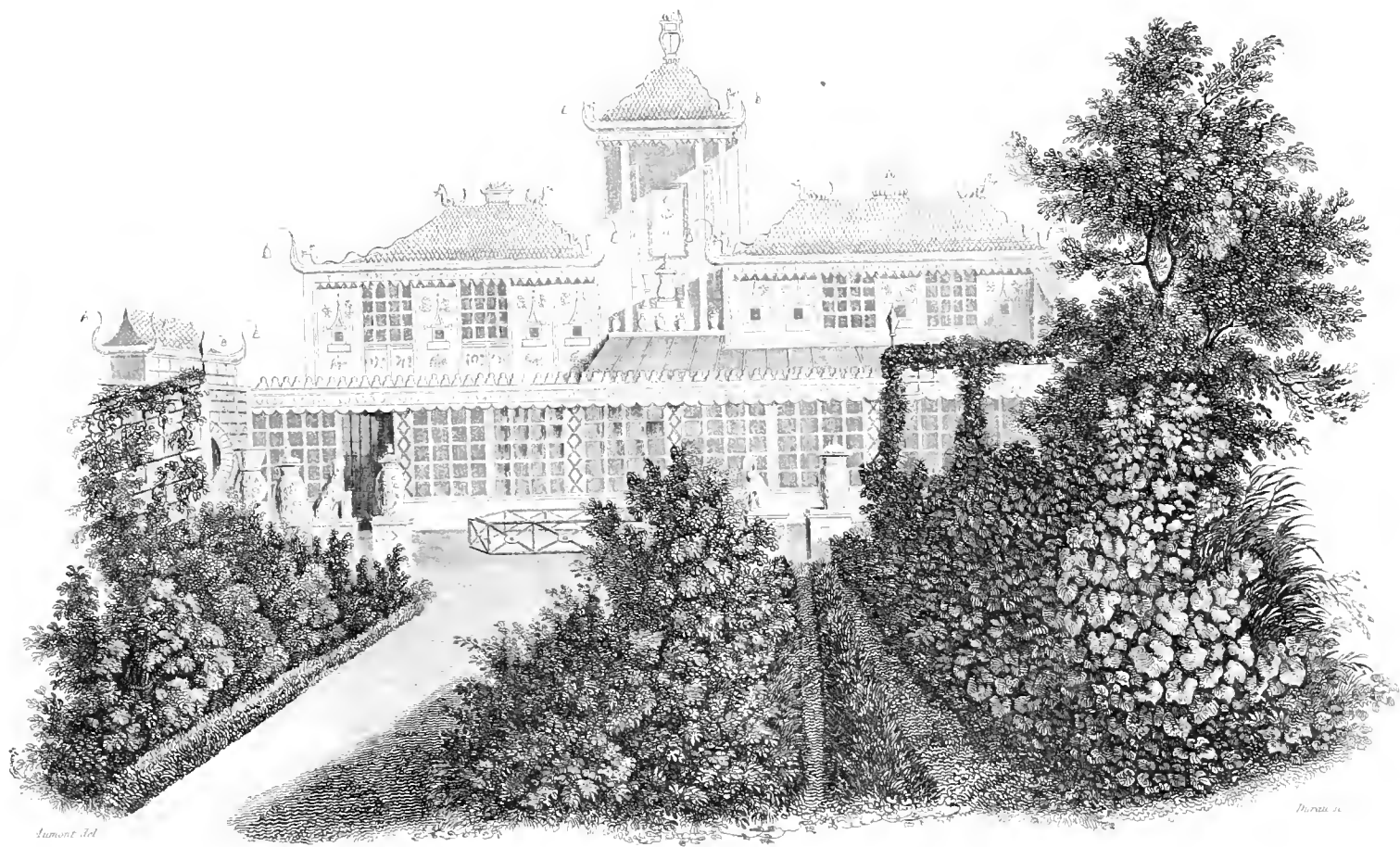
FABRIQUES D'ORNEMENT.





J. Armist. del.



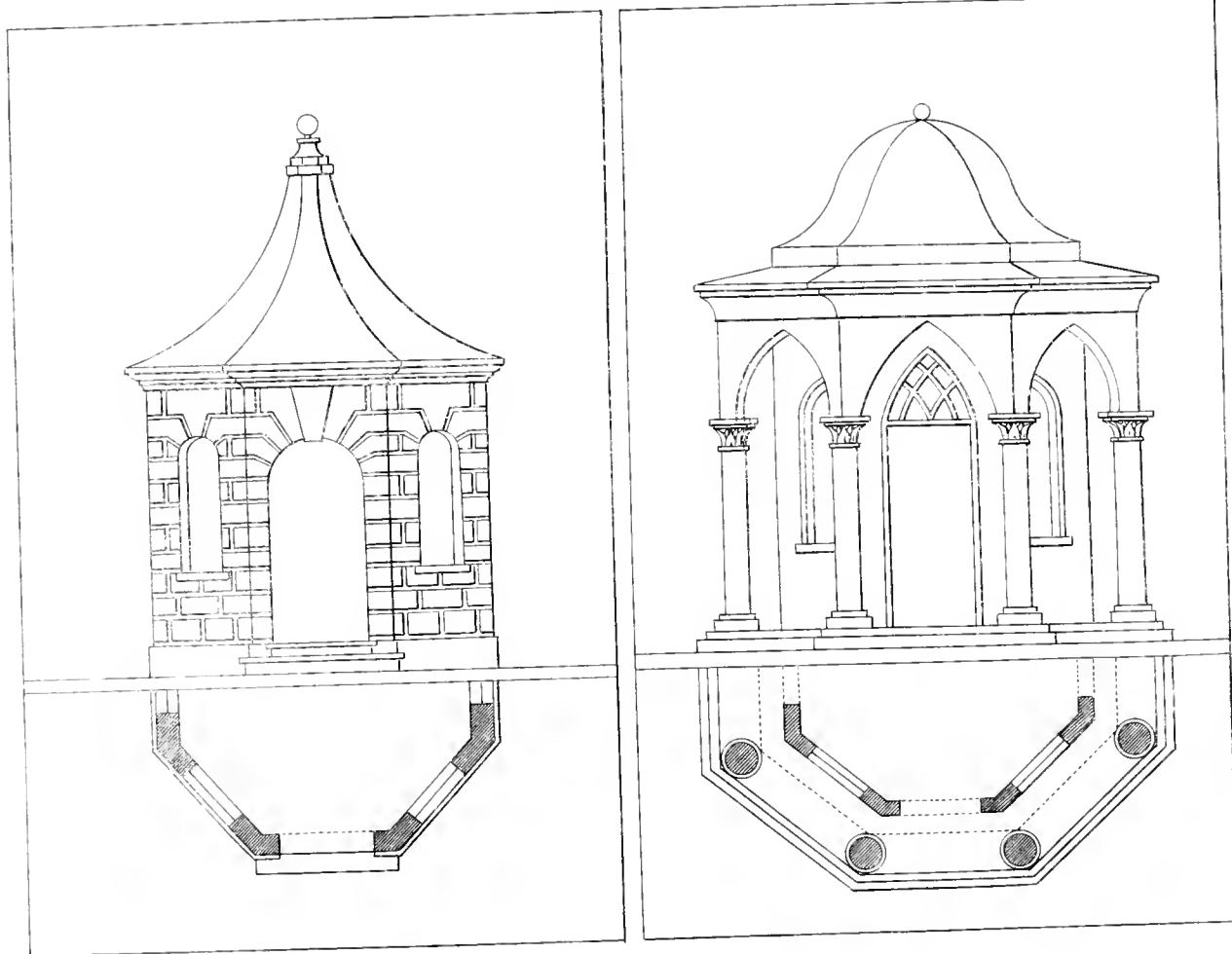


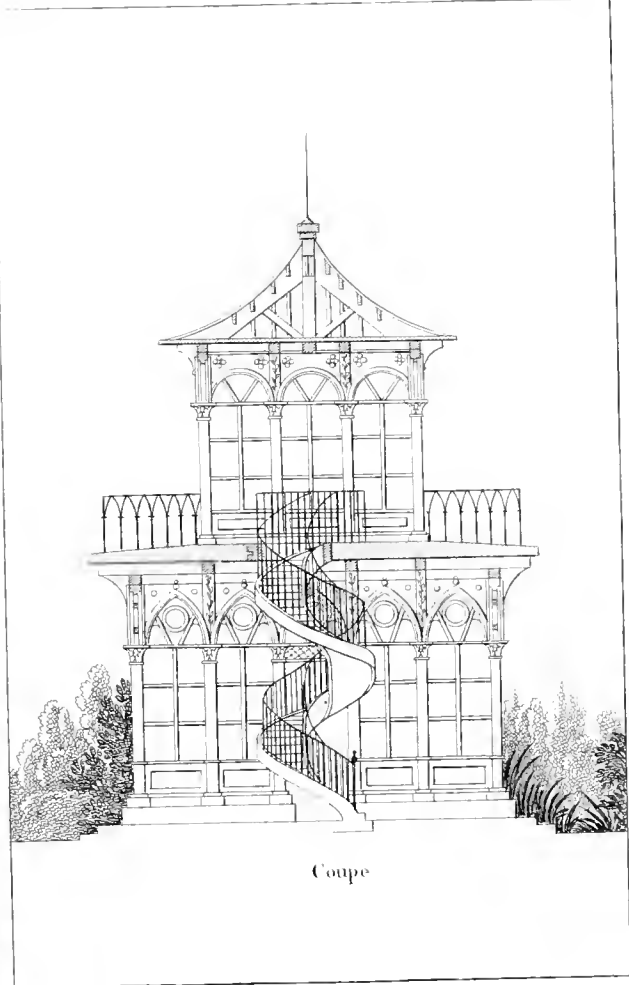
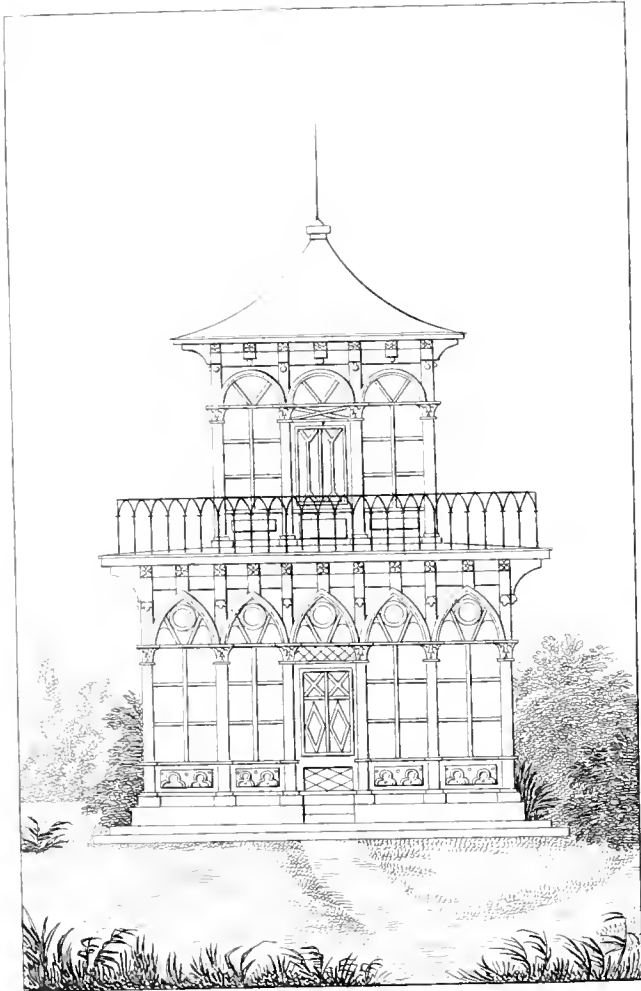
Amont 361

Mont 11

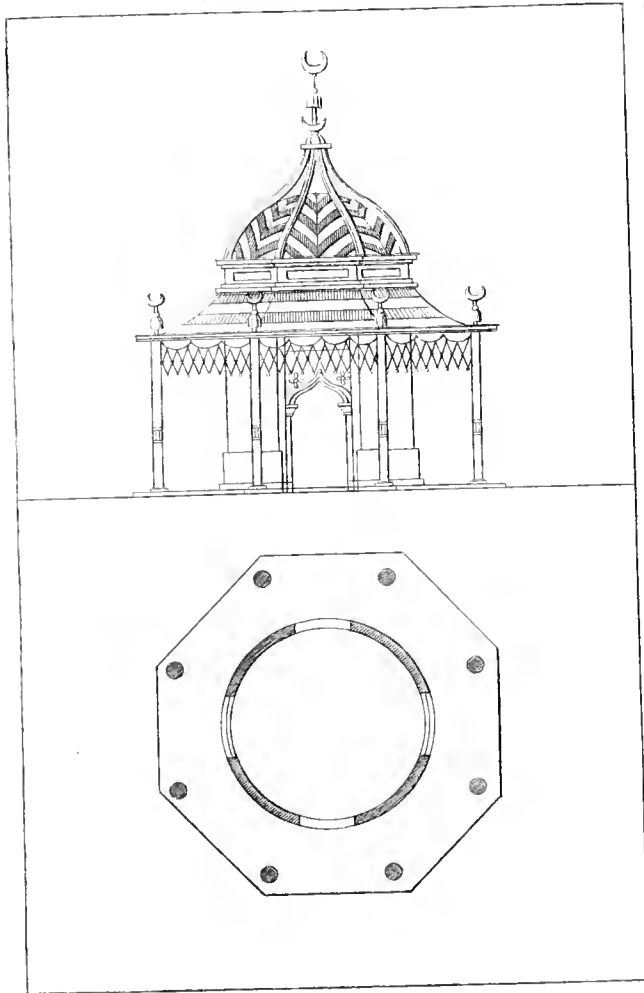
ORANGERIE CHINOISE CHEZ M^r PANCKOUCKE.

Pl. 102



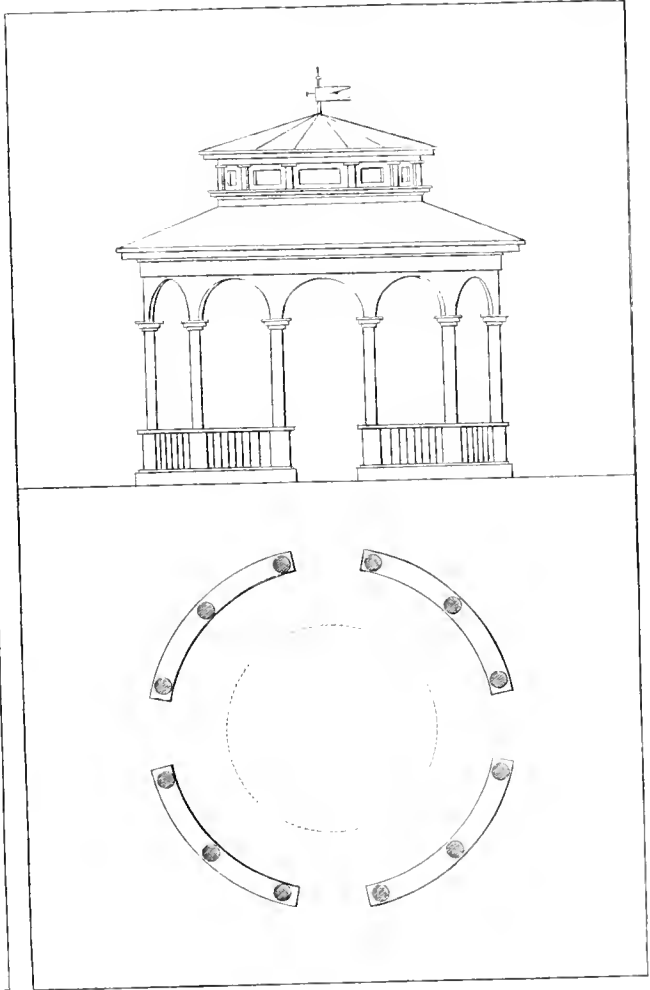


PAVILLON TURC.

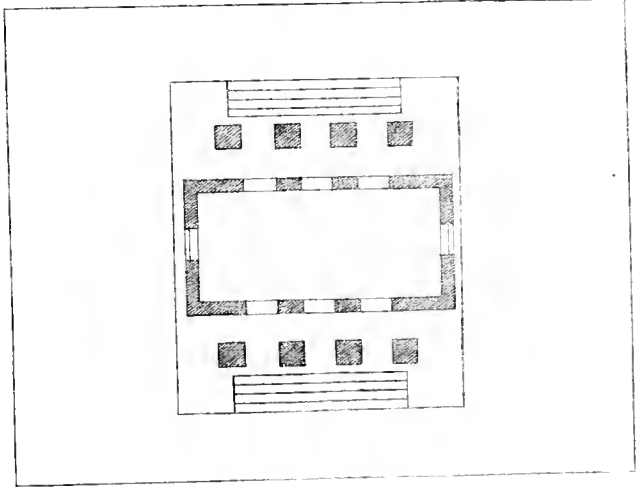
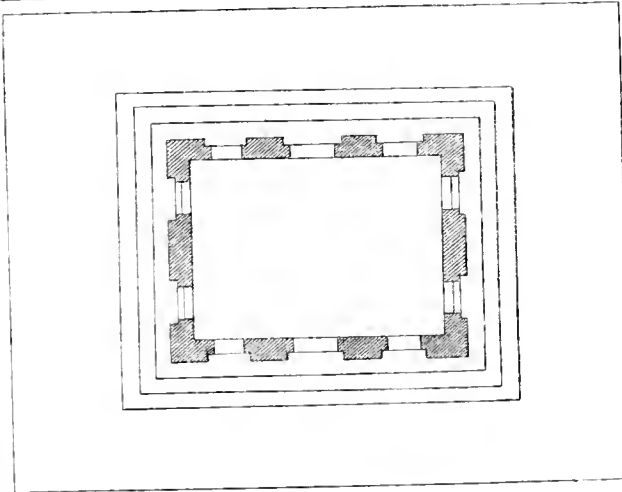
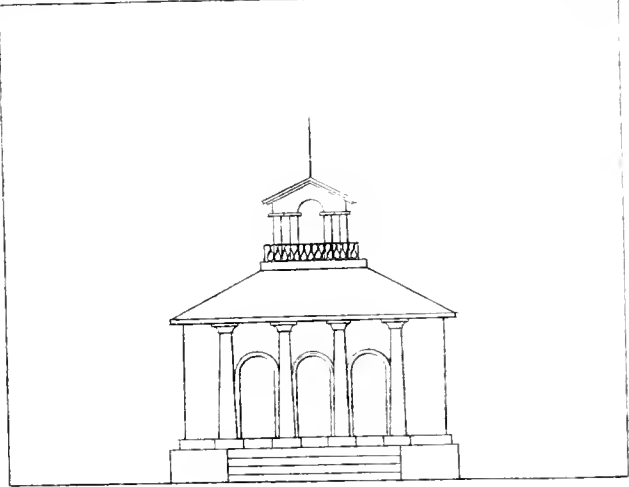
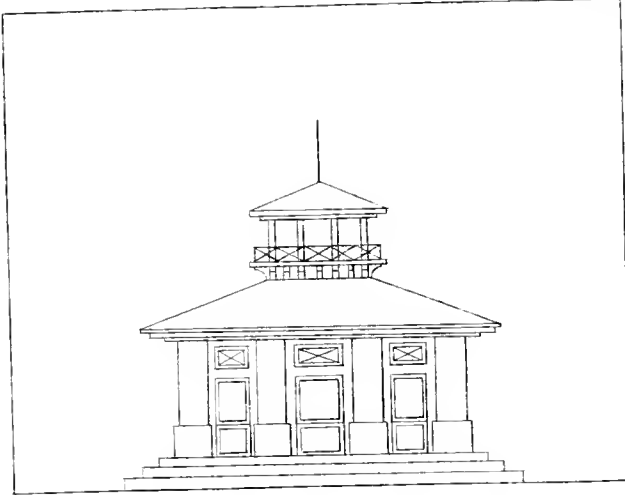


ROTONDE.

Pl. 105.



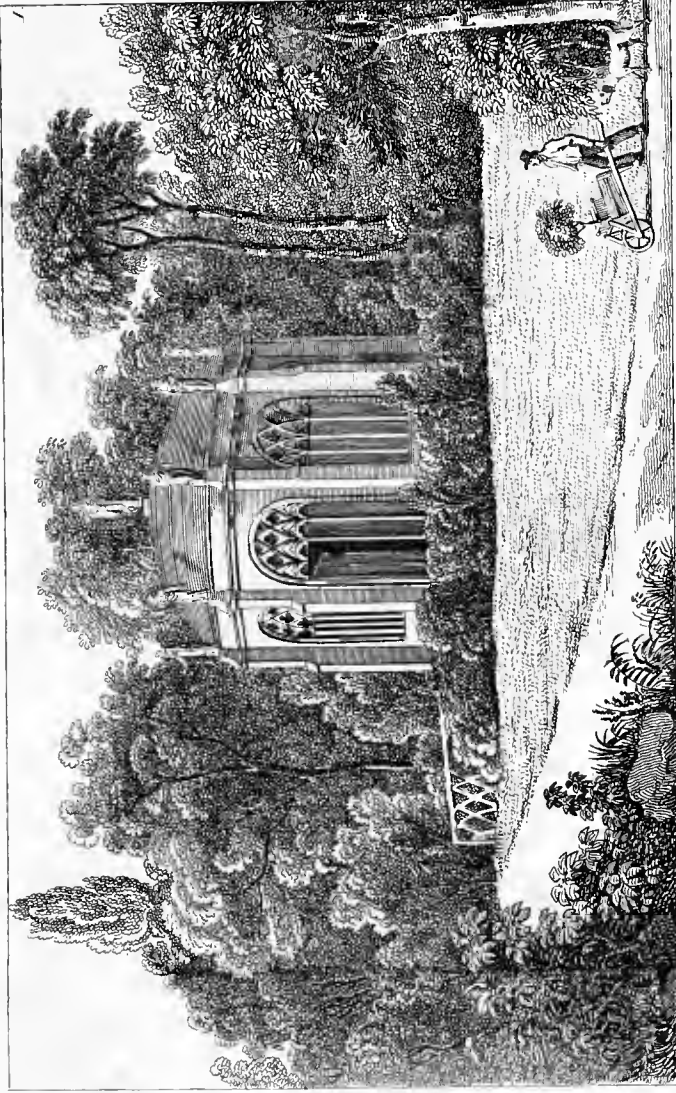




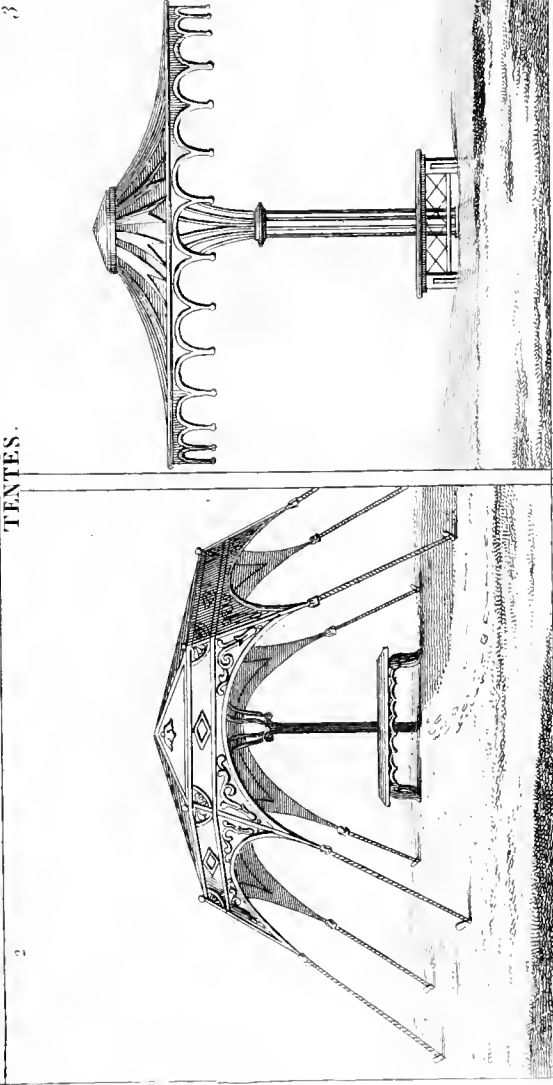


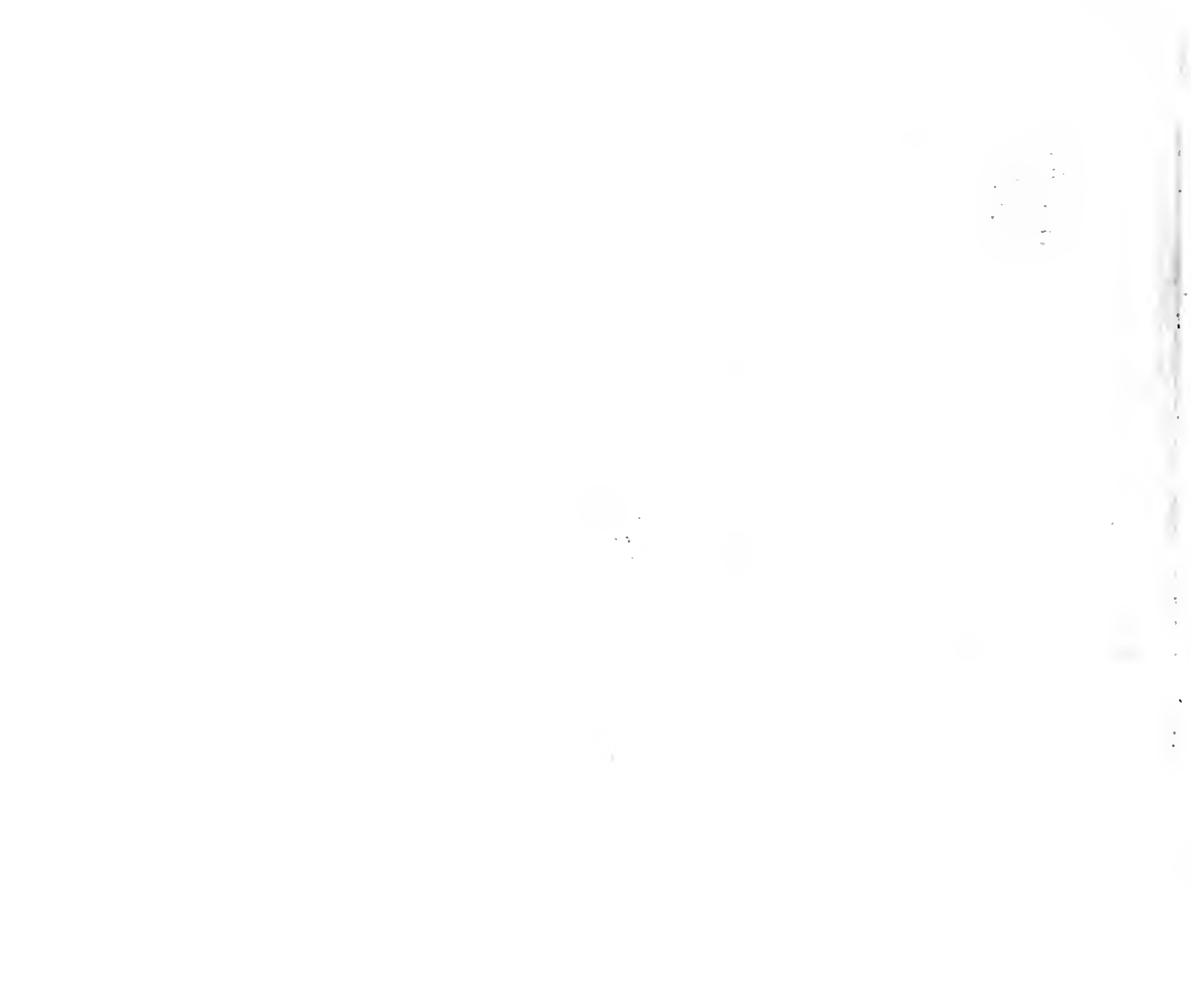
PAVILLON.

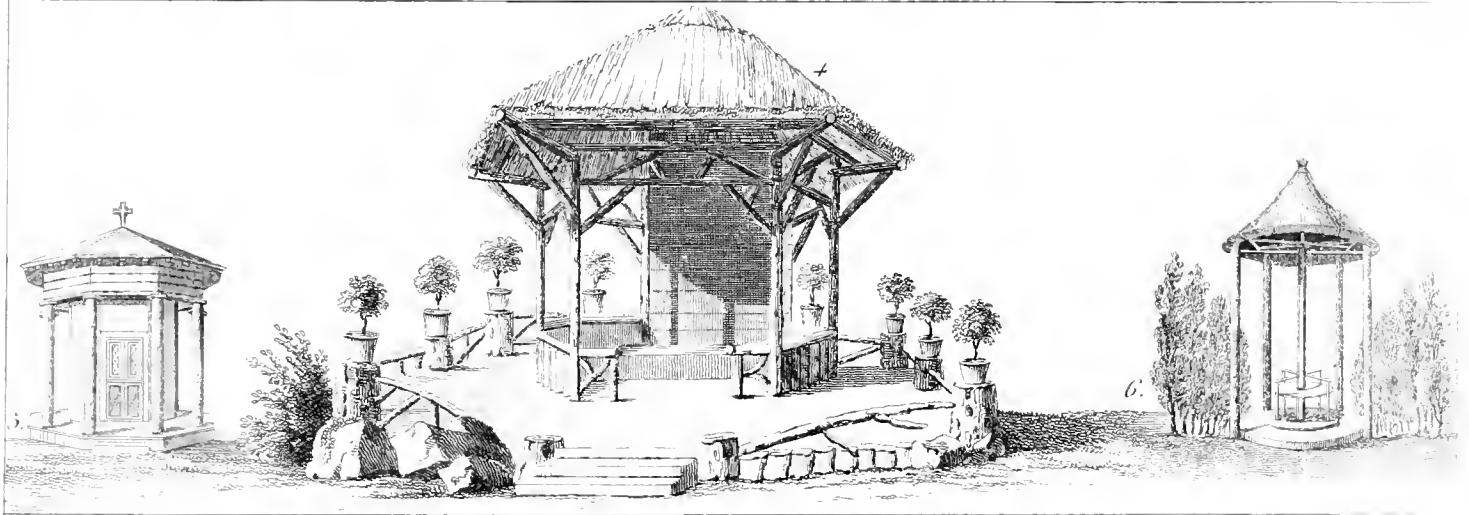
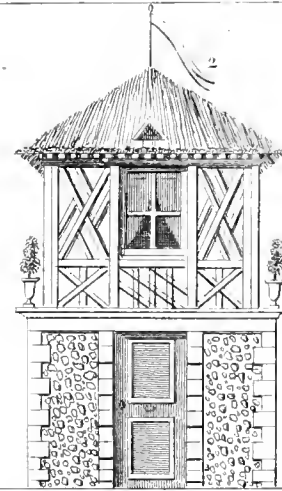
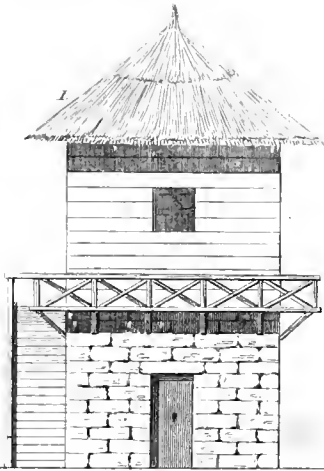
Pl. no. 7

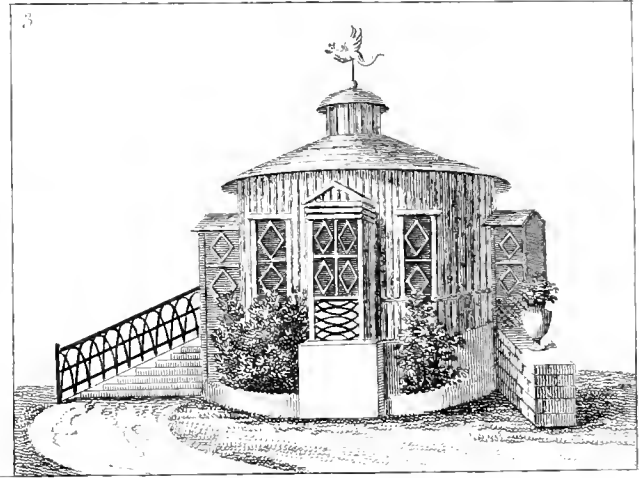
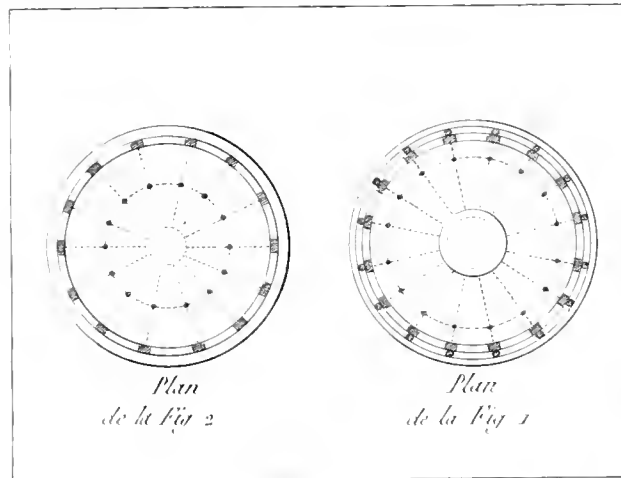
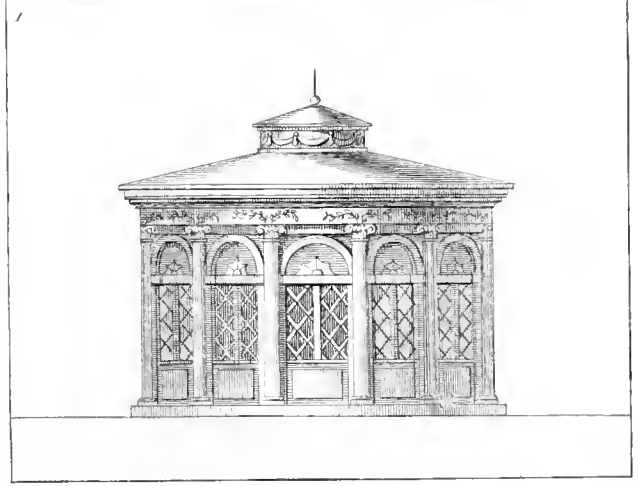
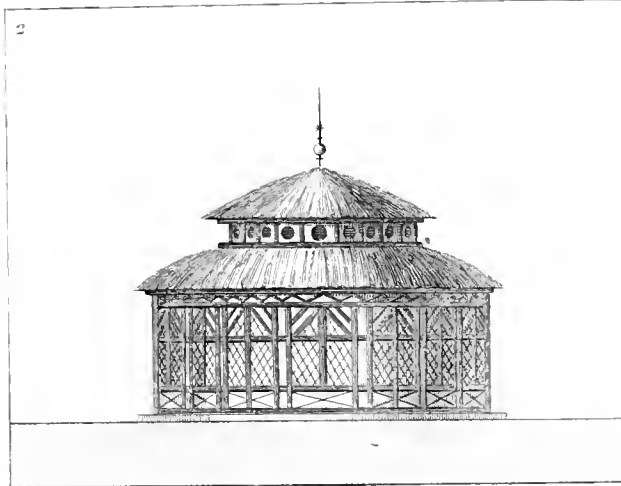


TENTES.

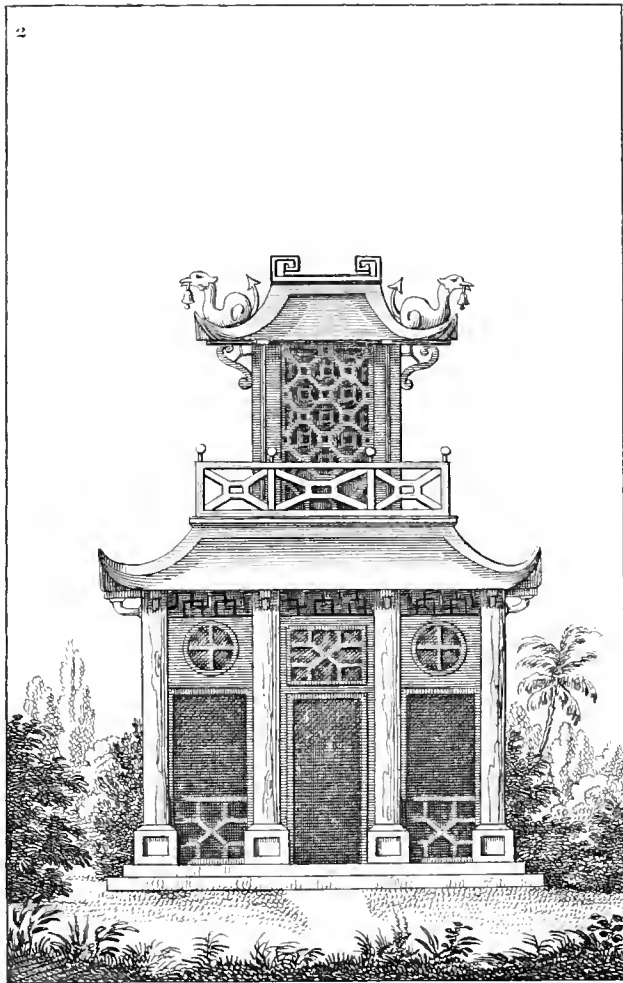
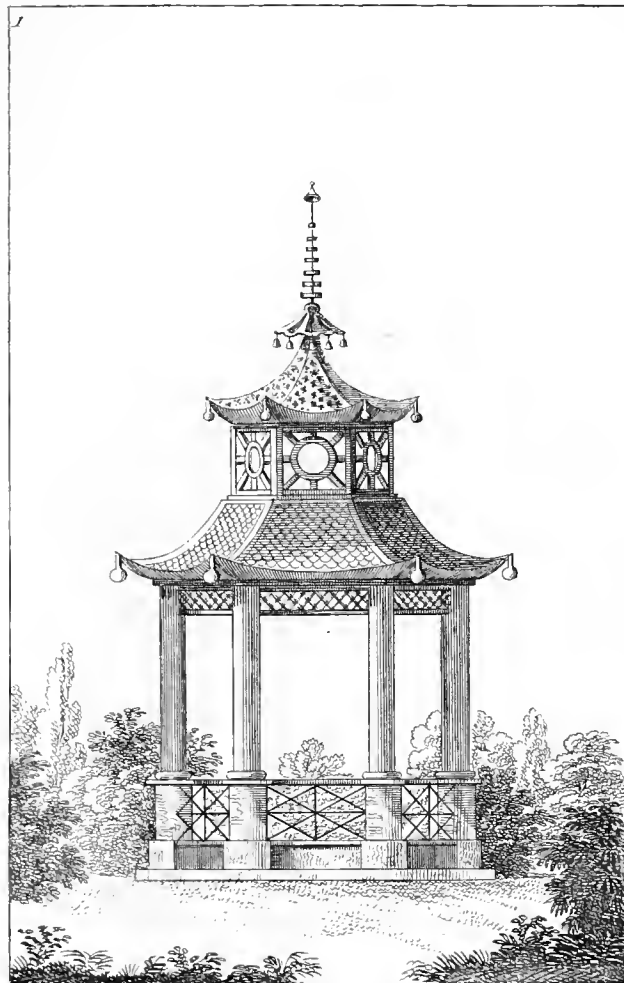








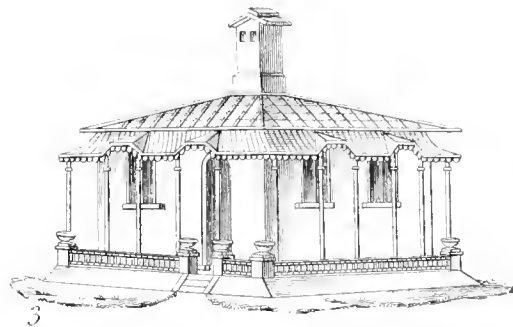




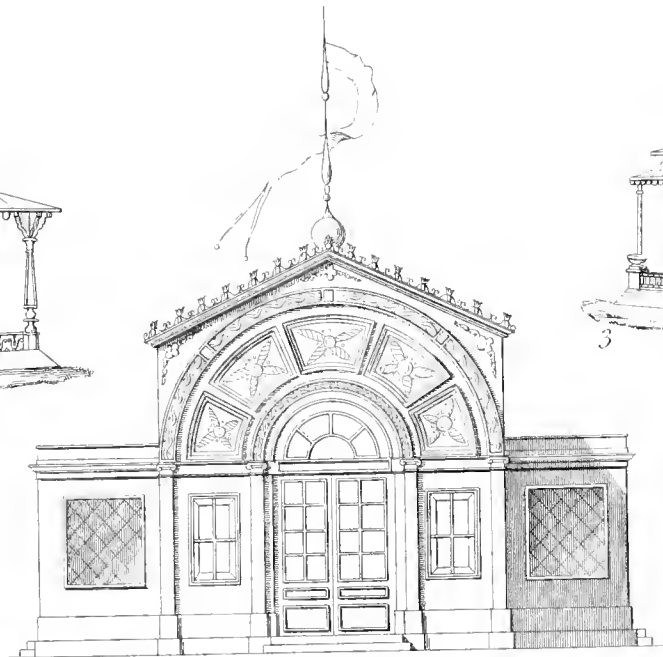




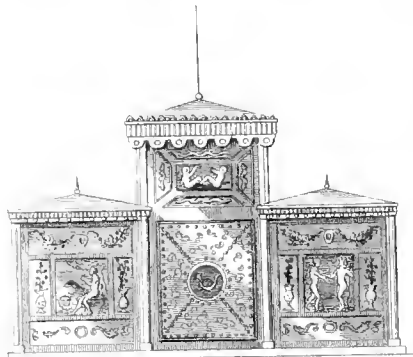
2



3



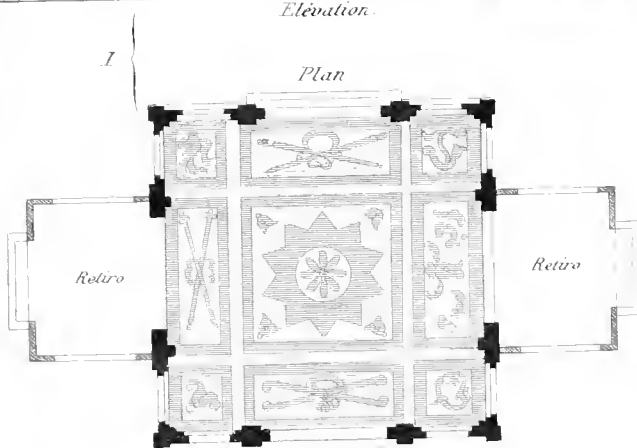
Elevation



Pavillon de décoration

Plan

5

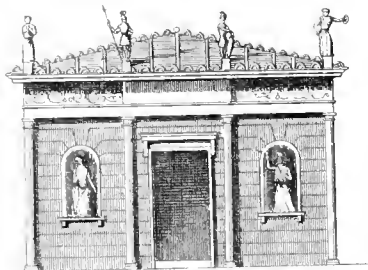


I

Plan

Retiro

Retiro



6

Theatre.

Gambert & London 1770

1 2 3 4 5 metres

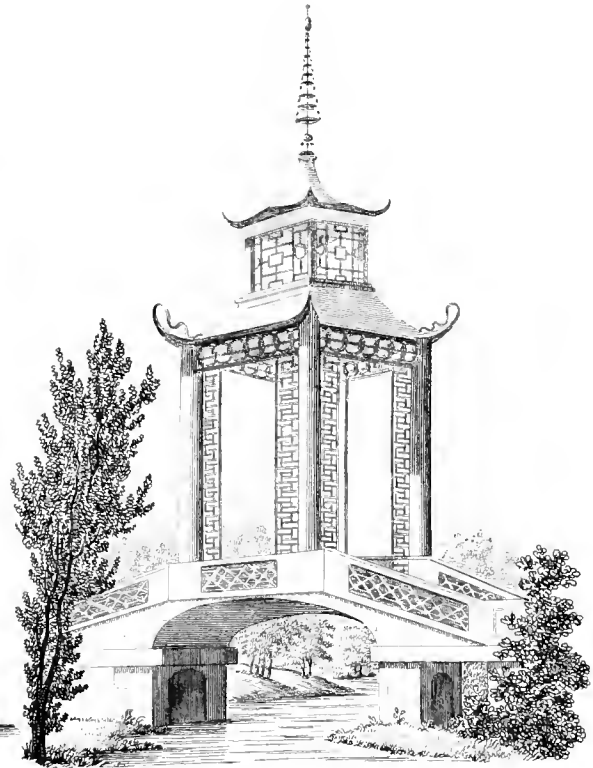
4

Durau

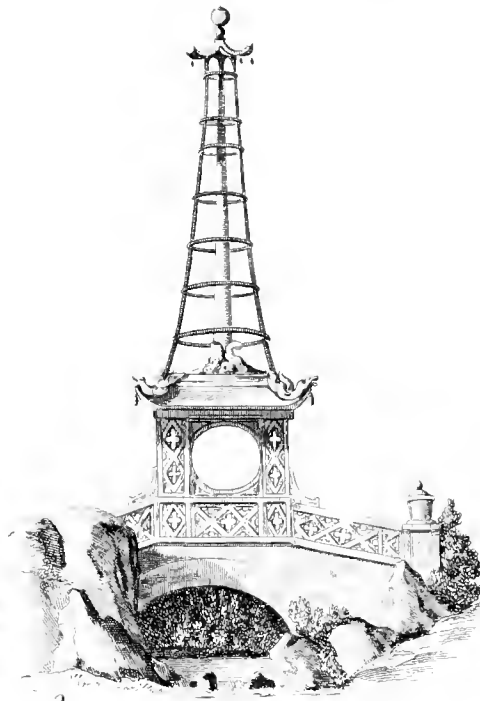




1



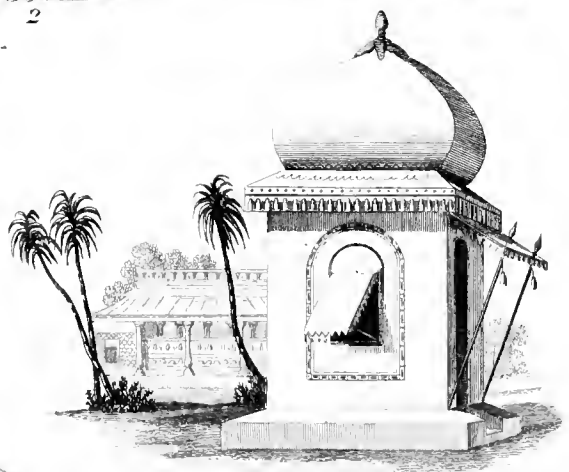
2



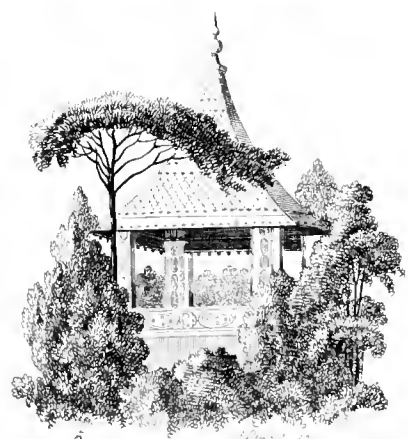
3



4



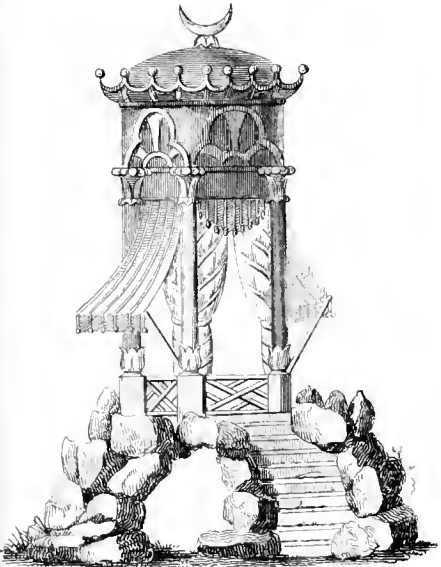
6



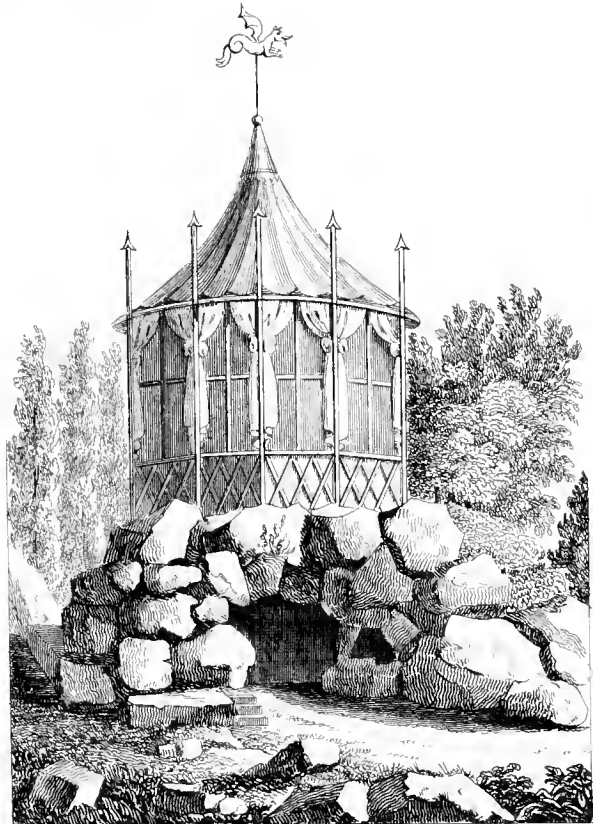
5

KIOSQUES.

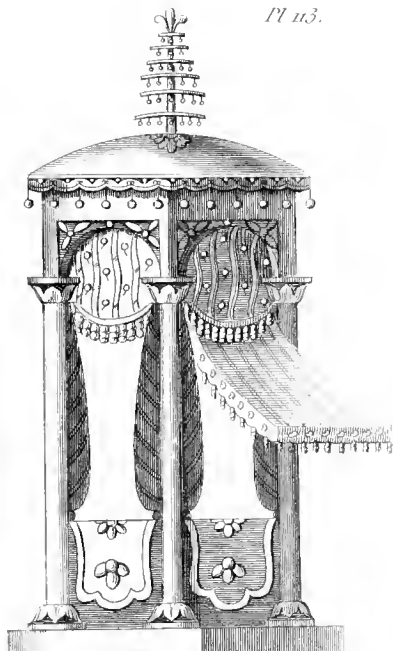




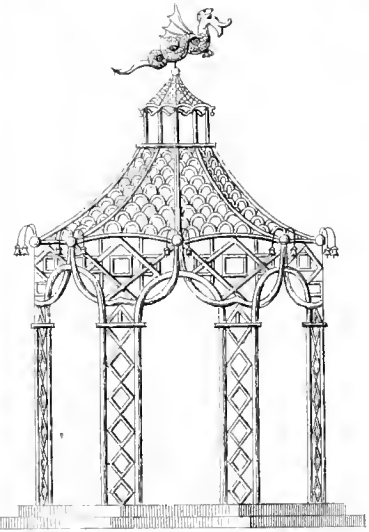
3



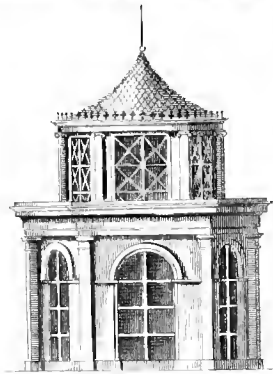
1



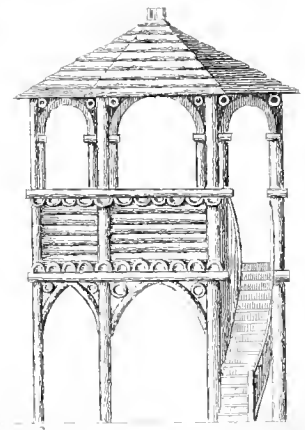
4



5



2



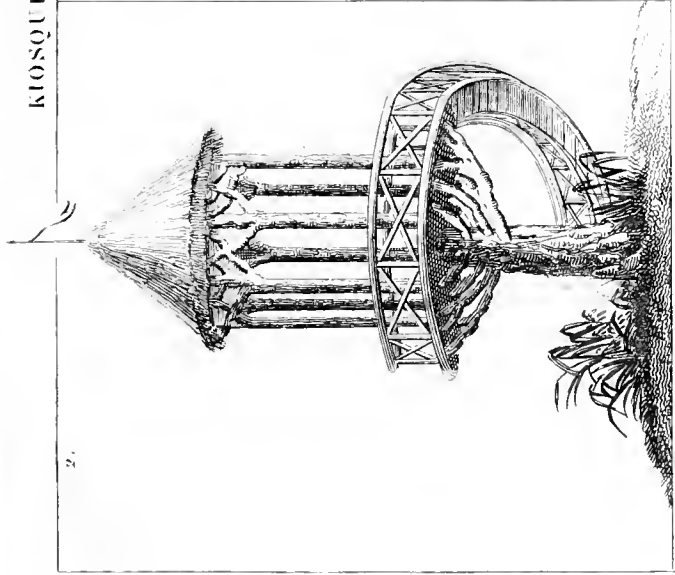
6



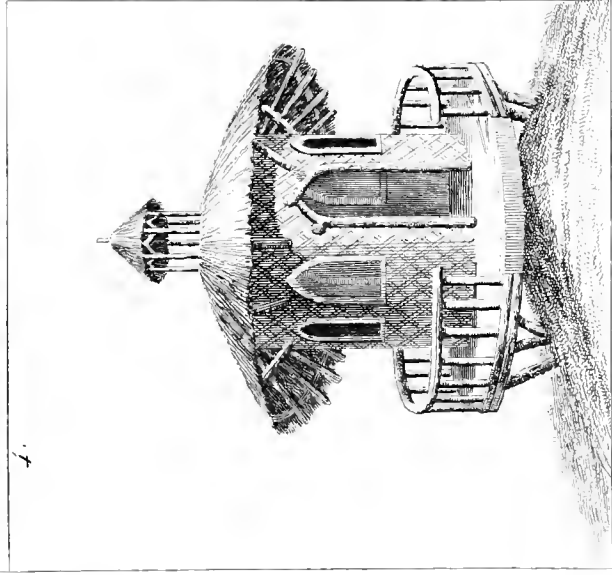
KIOSQUES



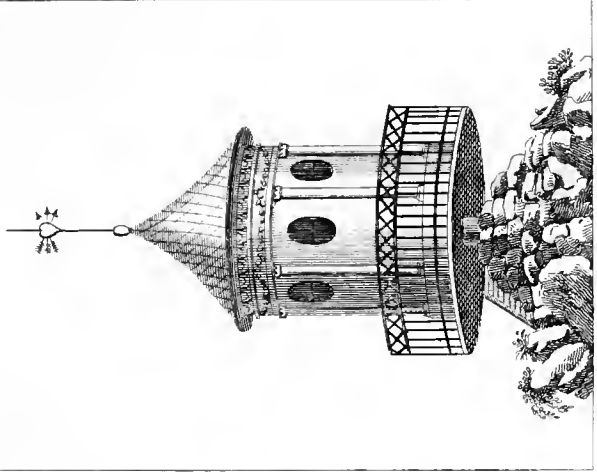
2.



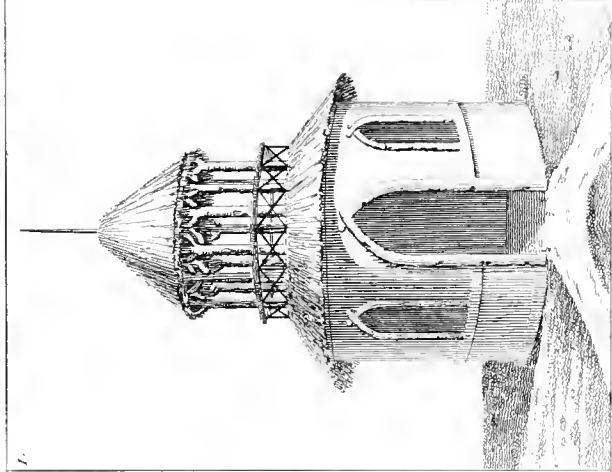
4.



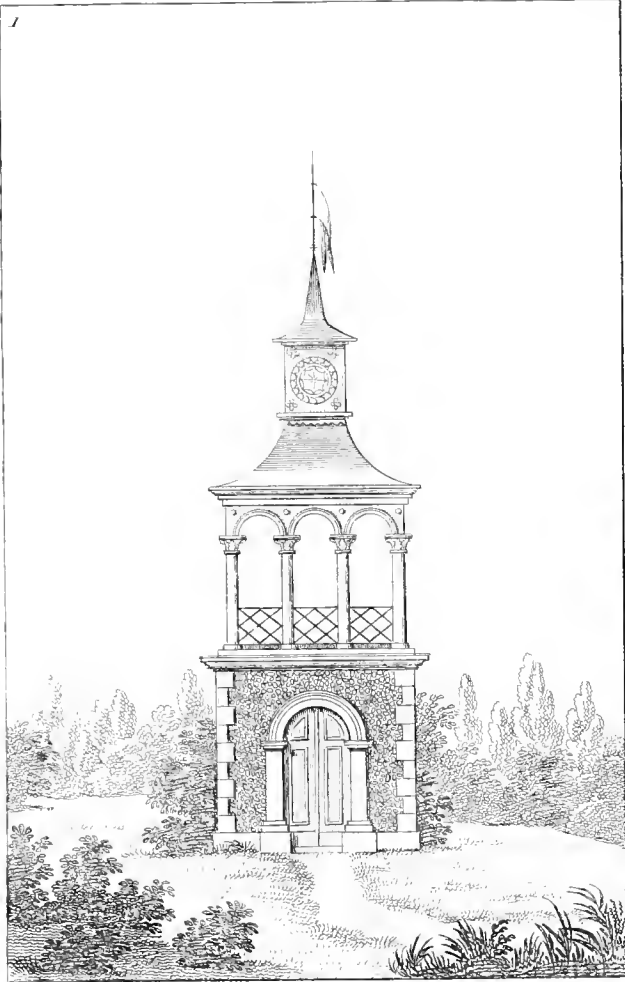
3.



1.



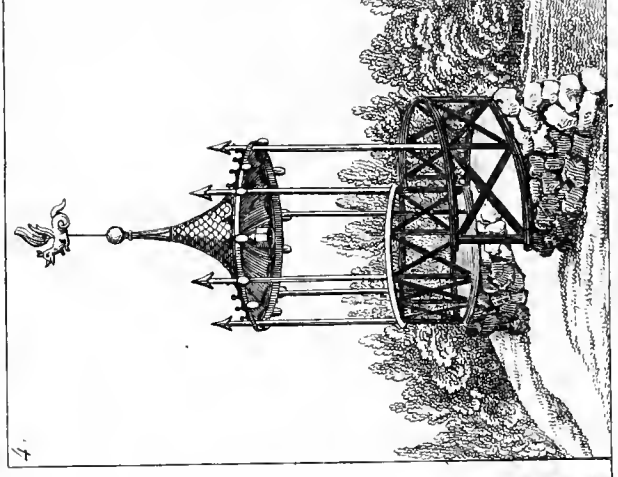
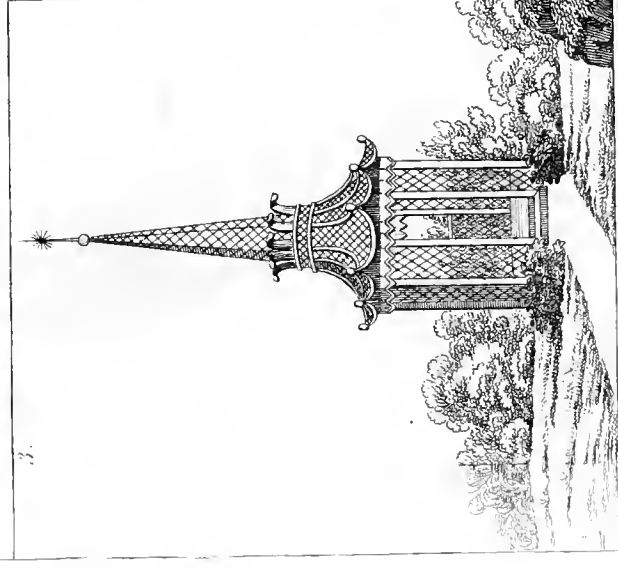
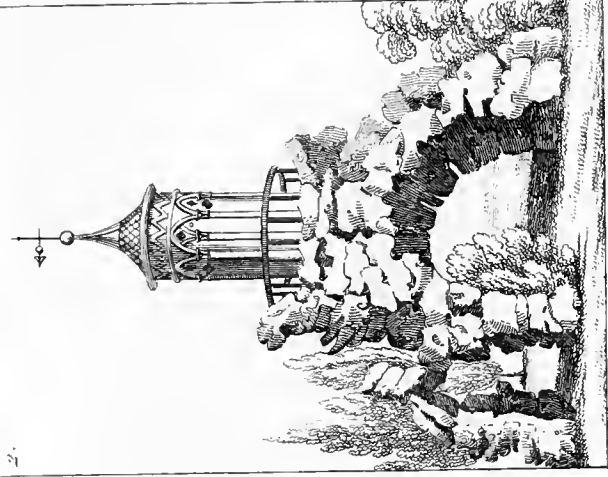
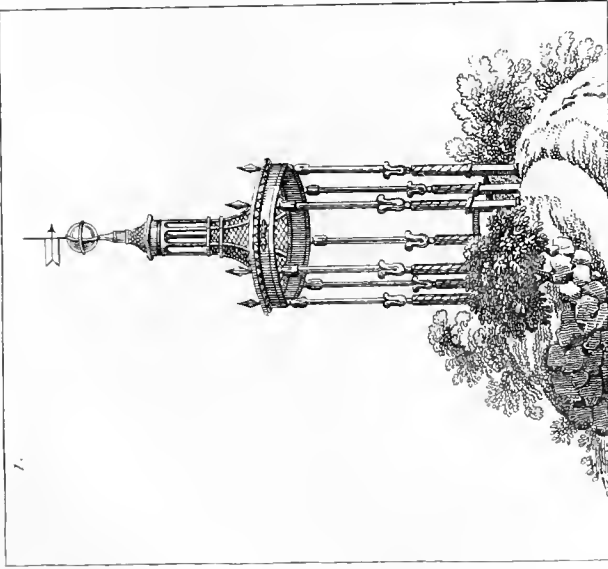






BELVEDERES.

Pl. no.

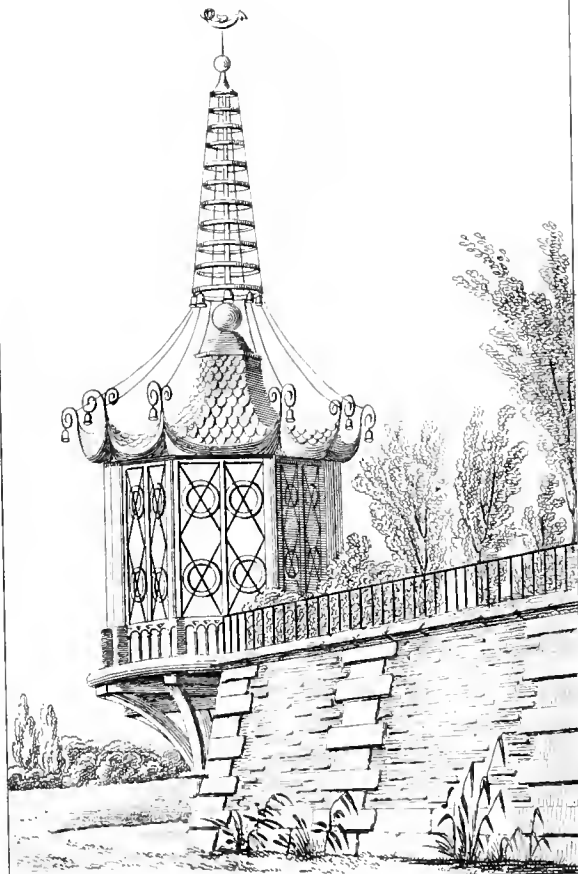
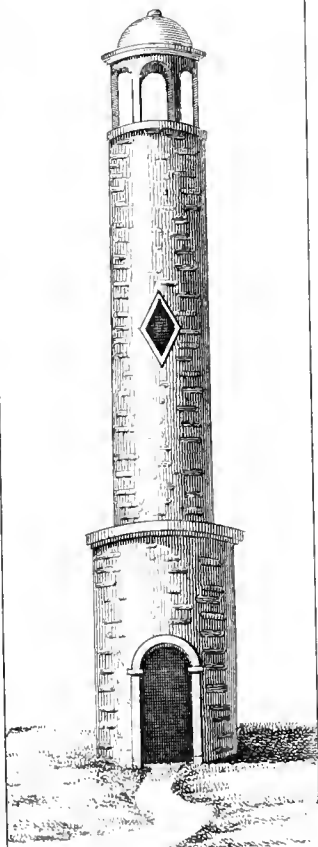
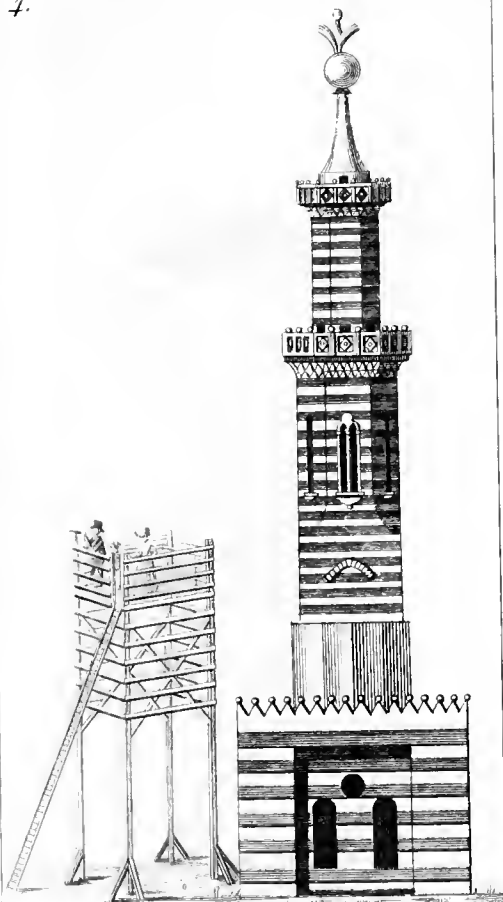


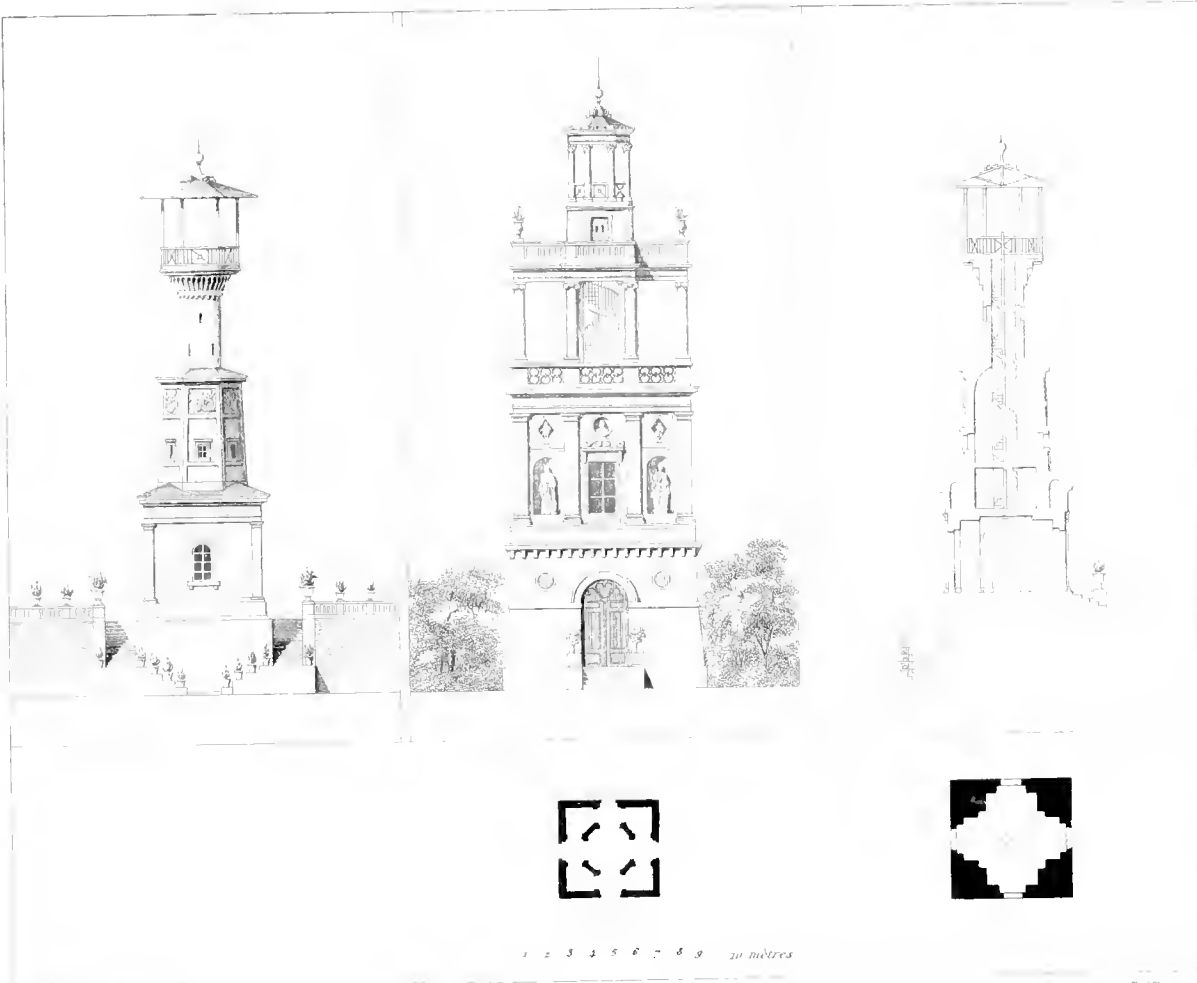


4.

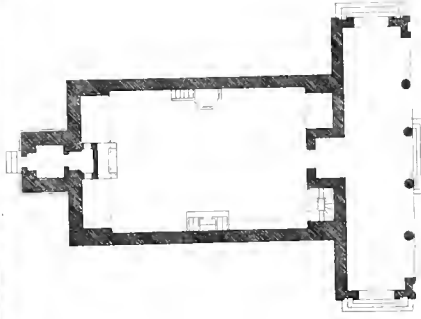
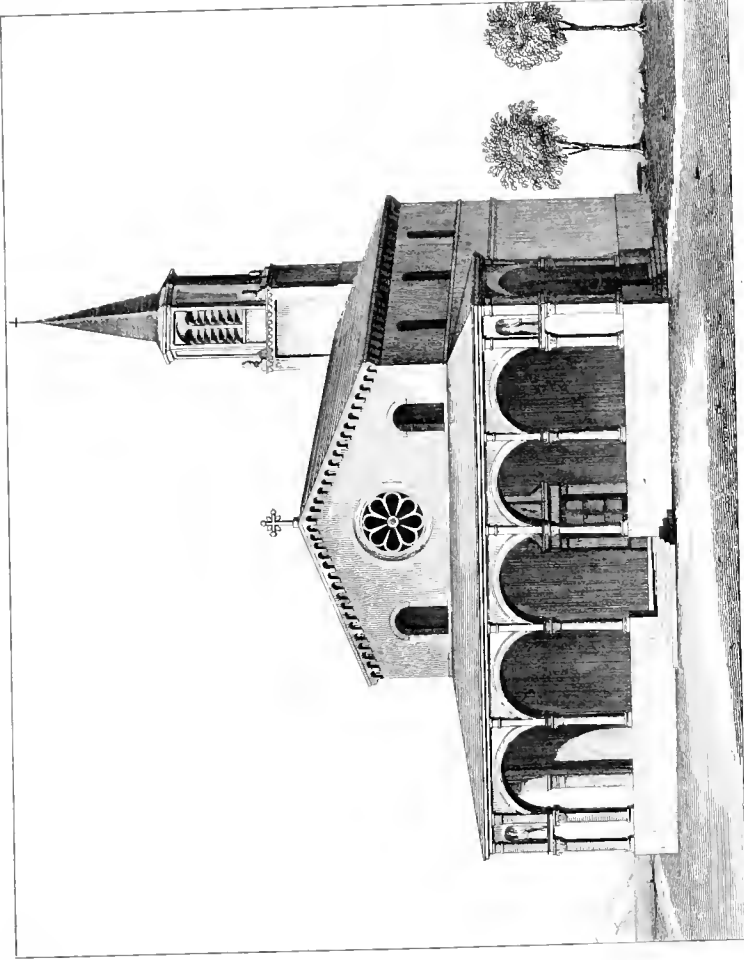
2.

3.



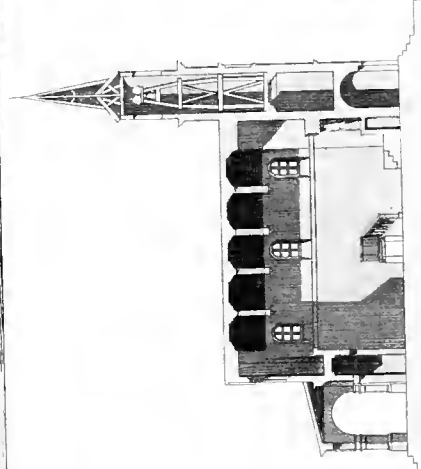






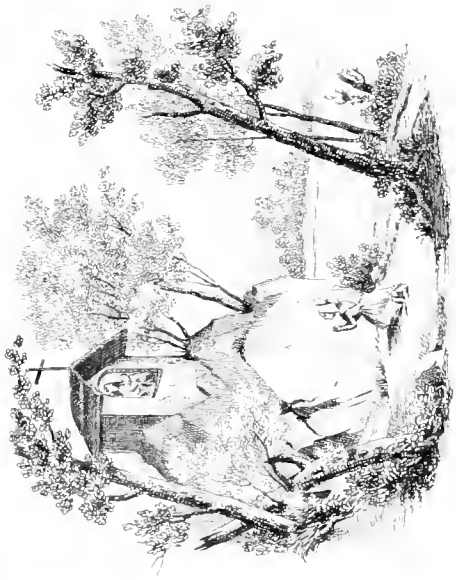
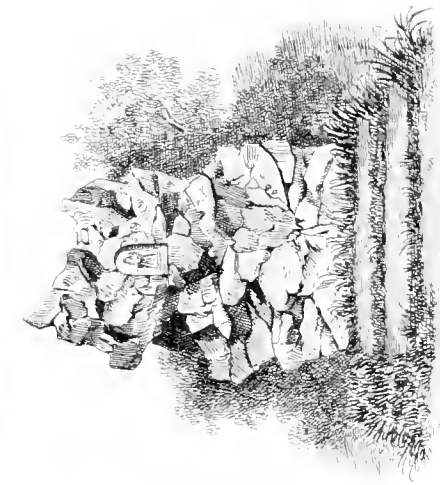
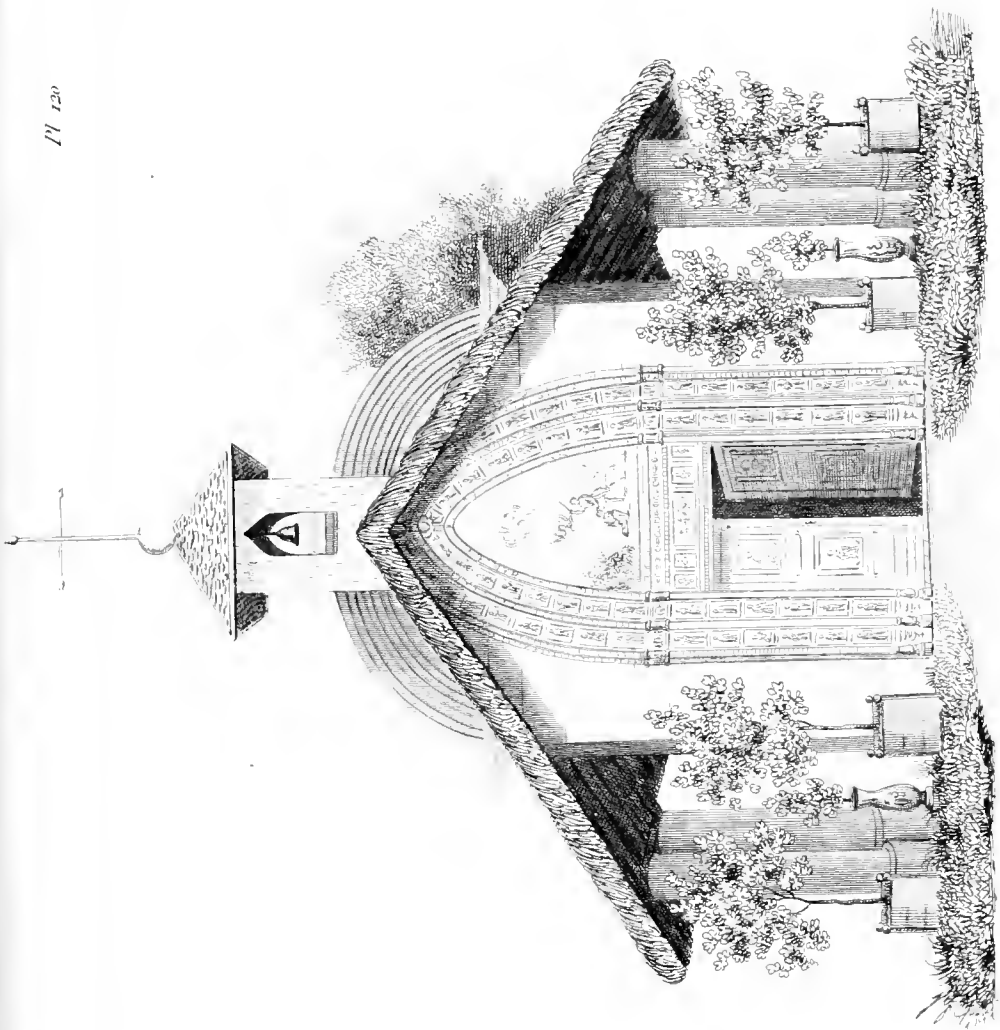
10 mètres

Pl. 119 A



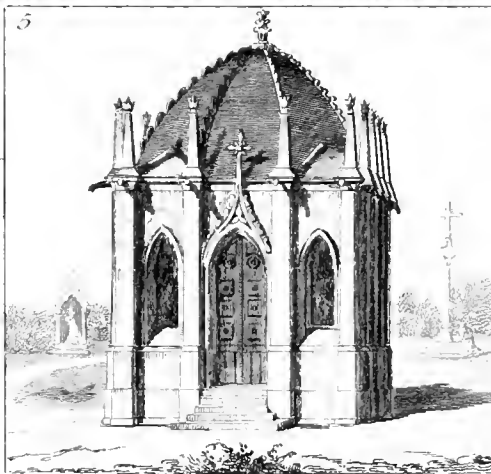
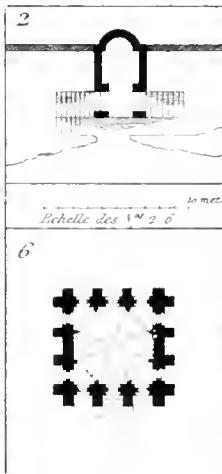
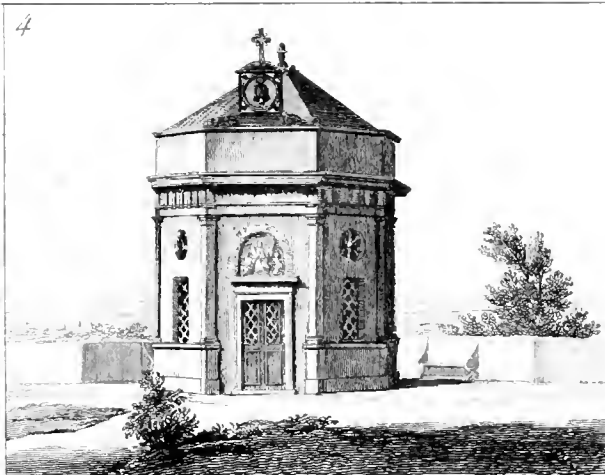
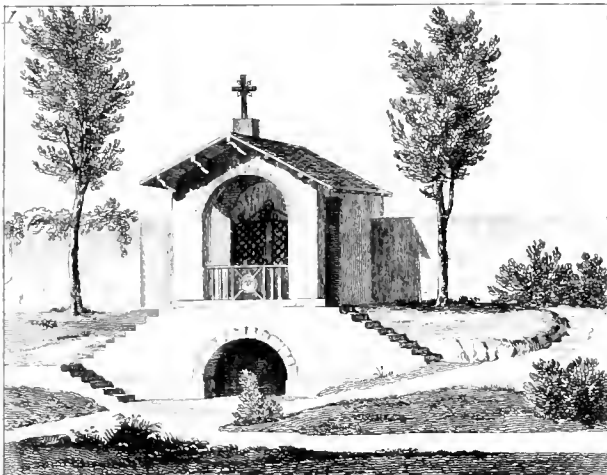
Pl. 119 B





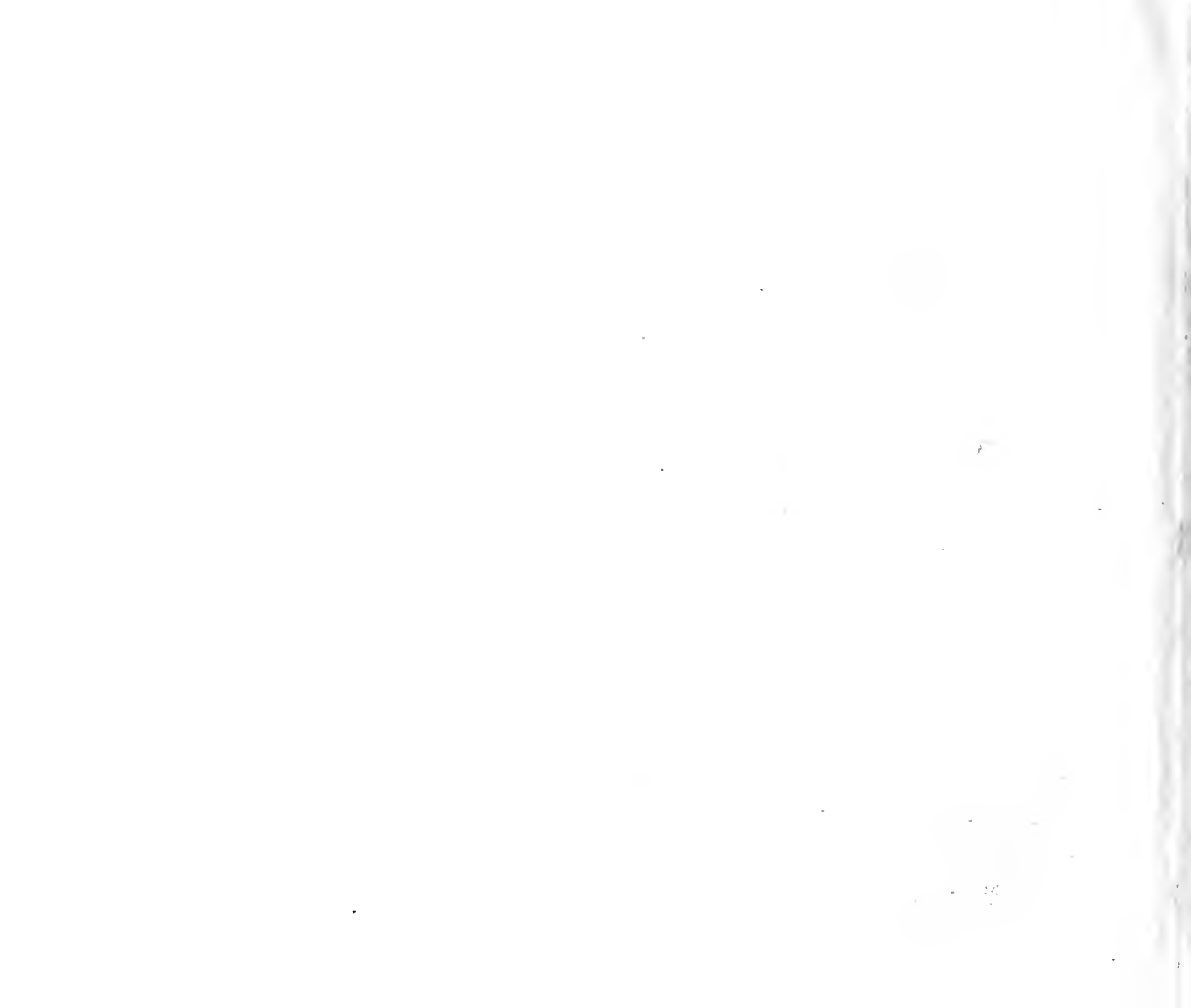
CHAPELLE — EN VOTO

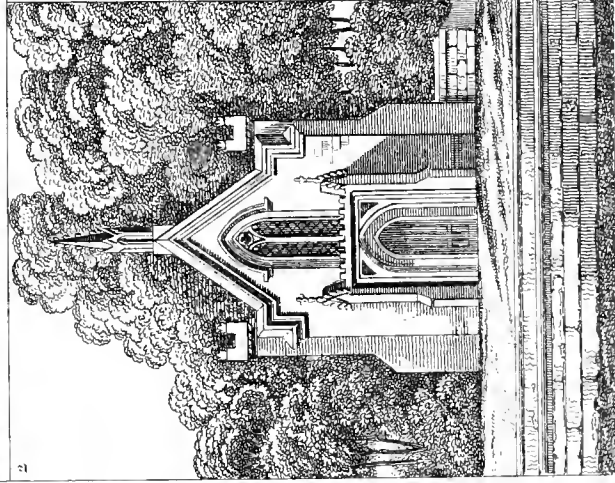
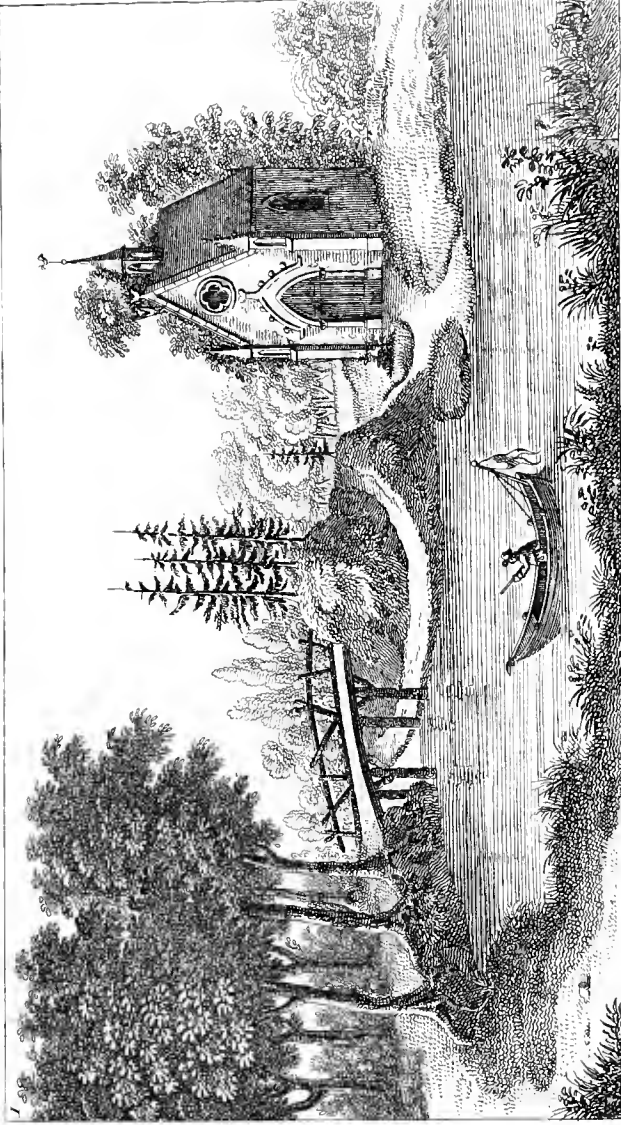




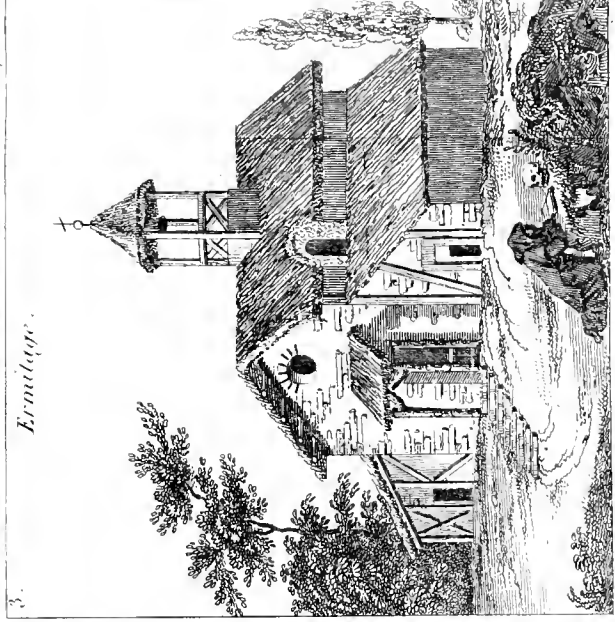
Carrière 120

Dureau 55



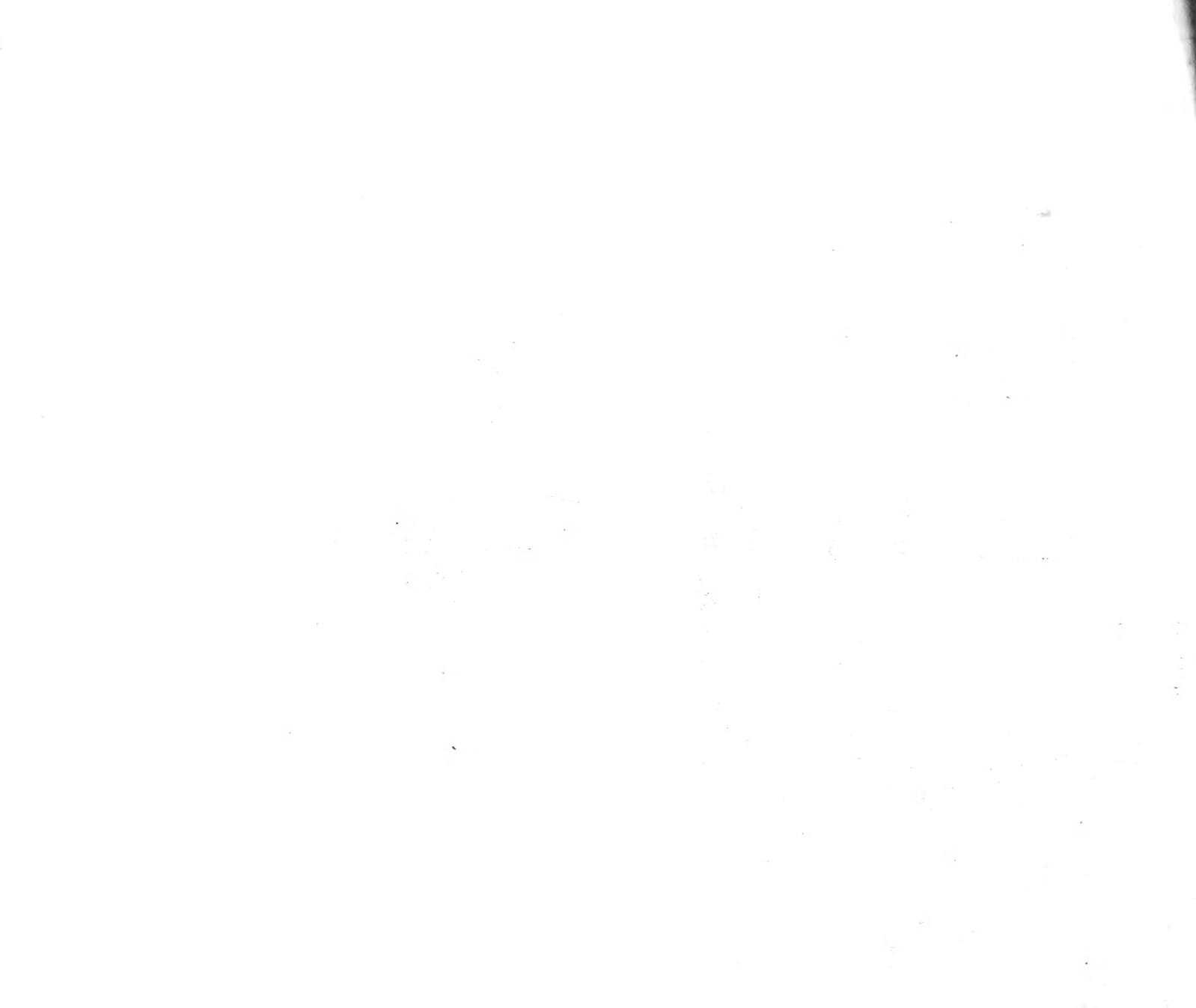


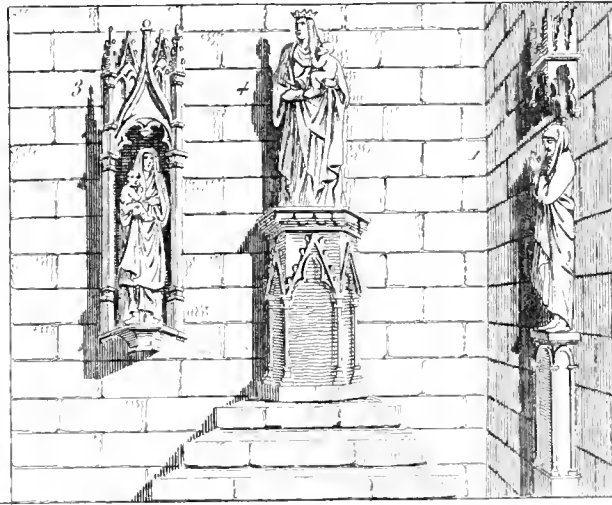
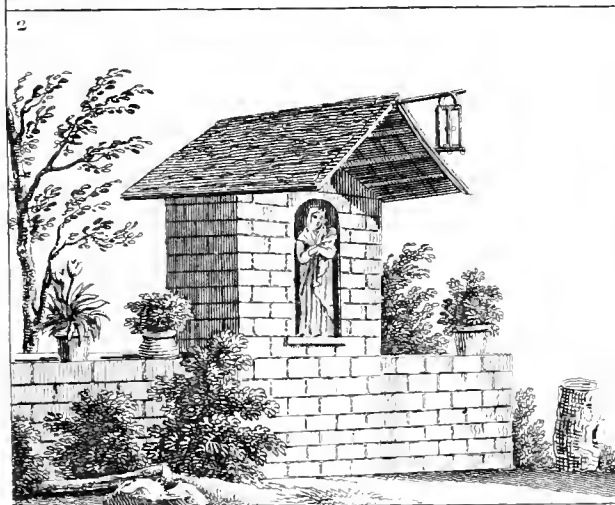
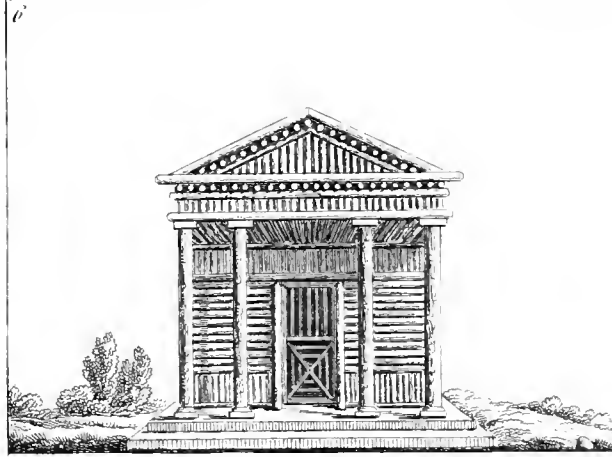
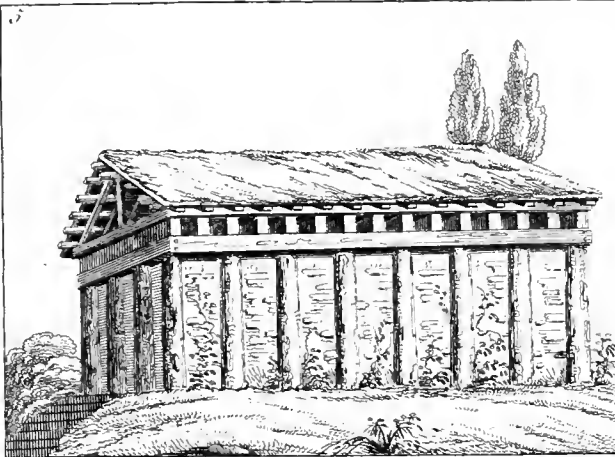
2



Ermitage.

3







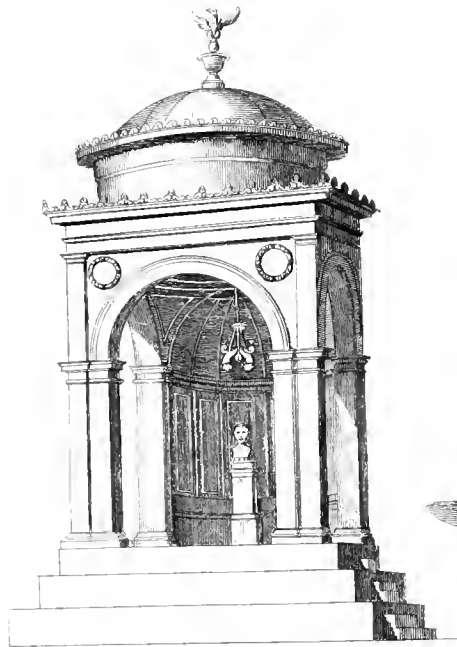


CROIX EX VOTO.





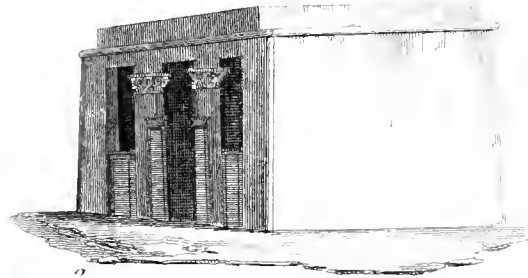
3



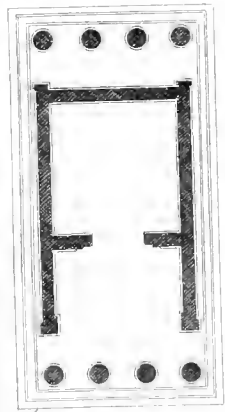
5



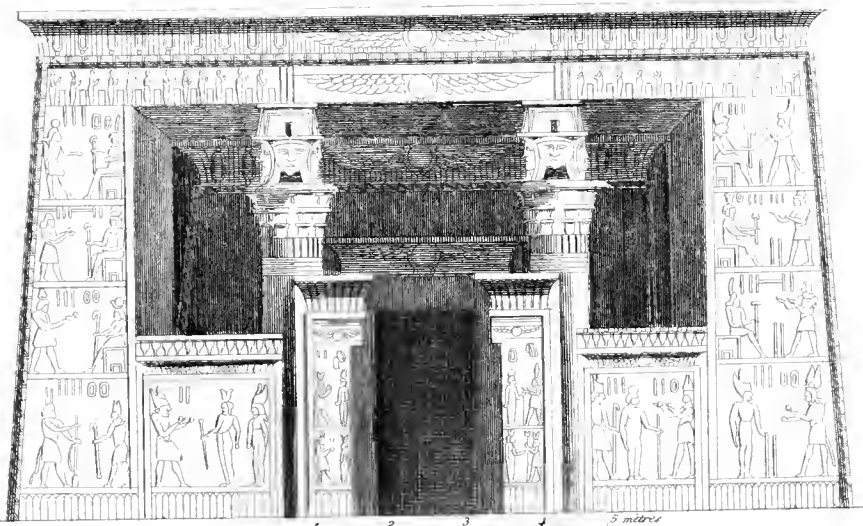
6



2



4



1

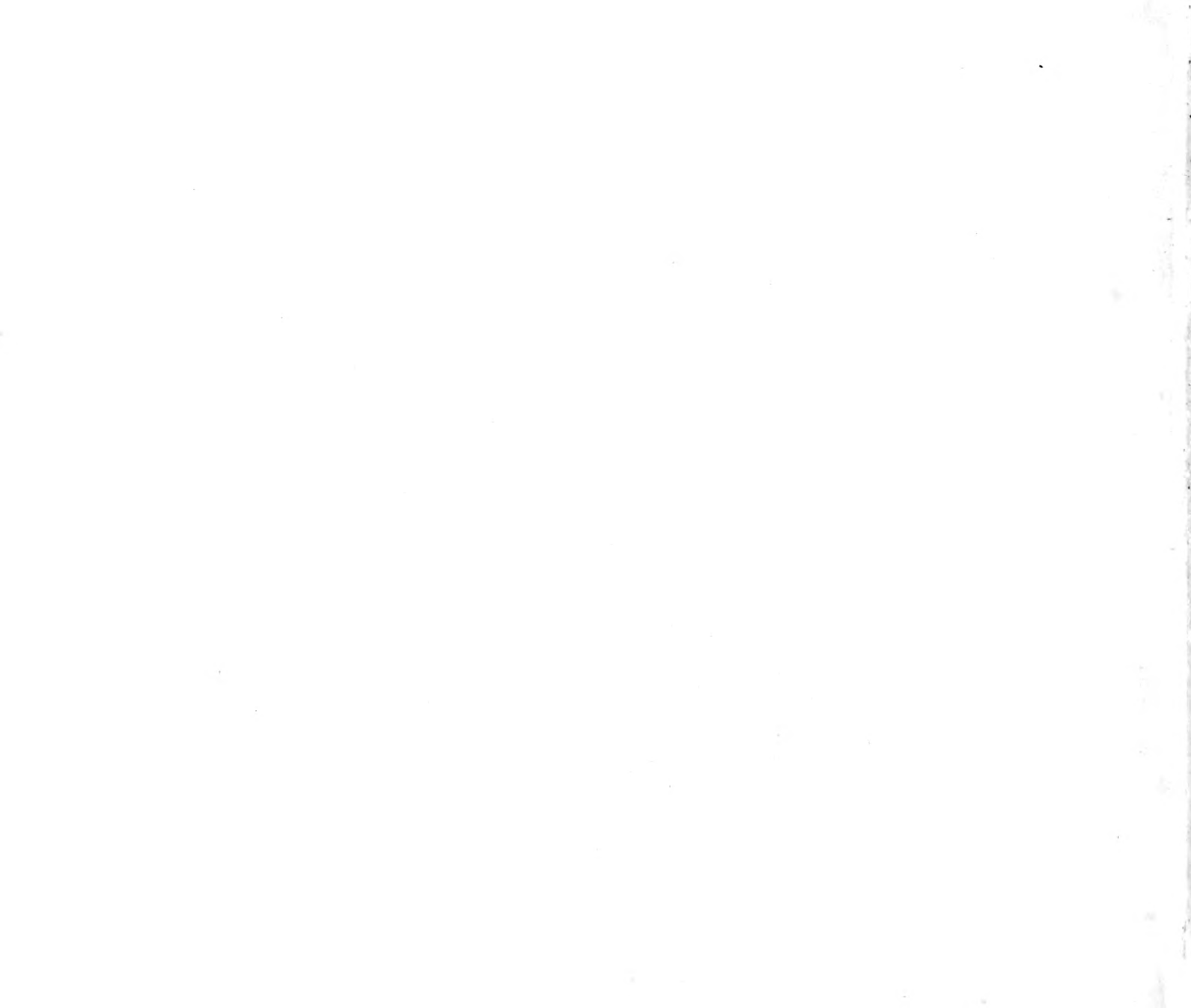
5 metres



7

Therap. sc.

MONUMENTS. TEMPLES.





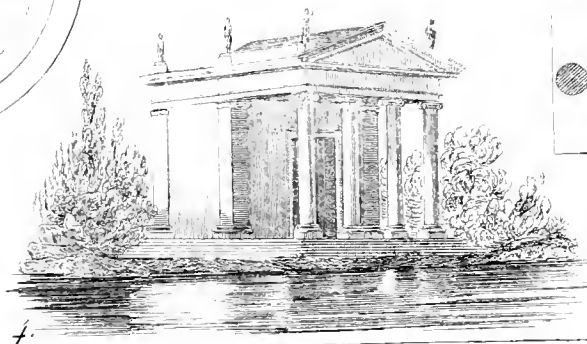
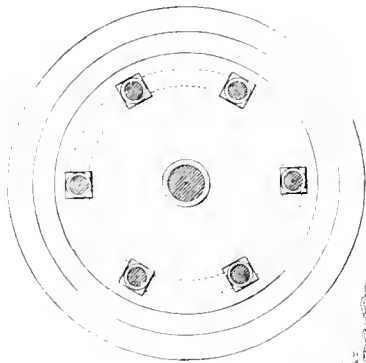
1.



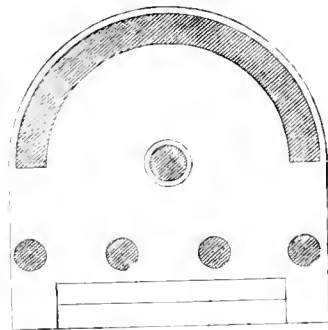
3.



2.

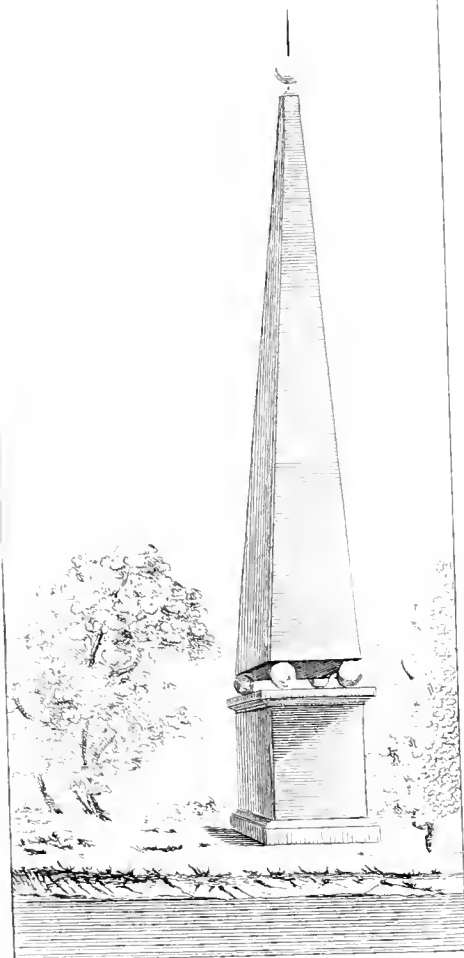


4.

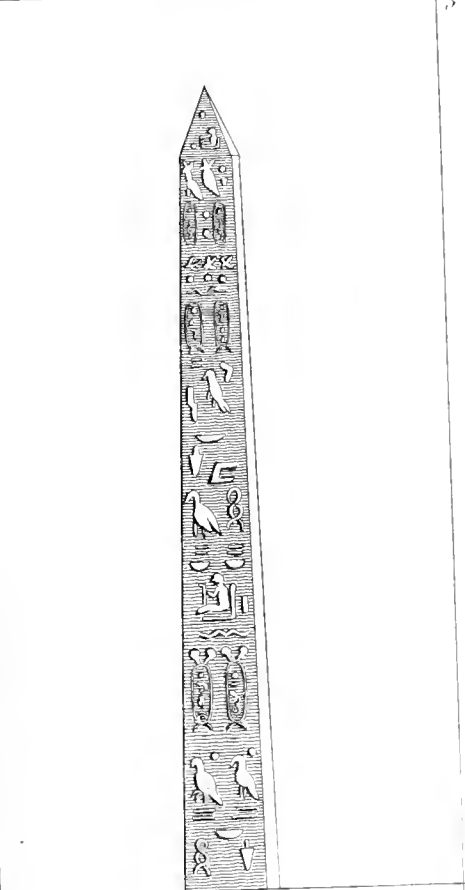




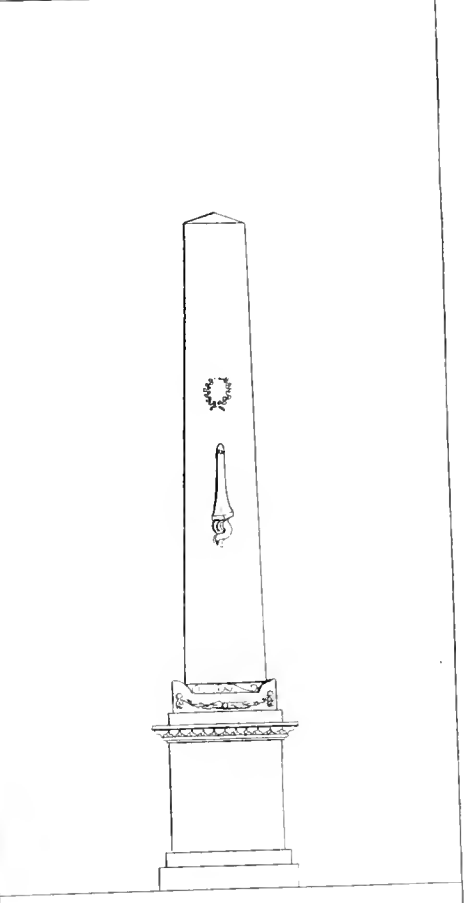
1



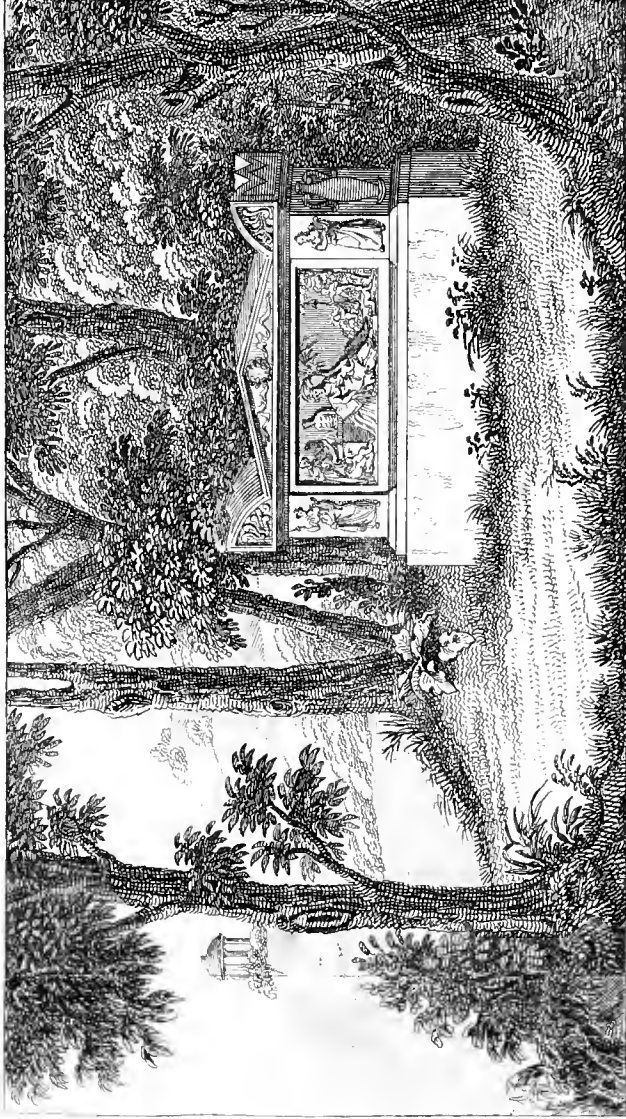
2



3

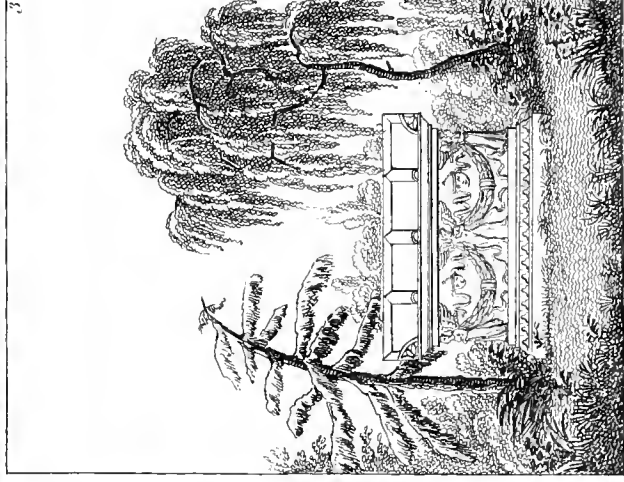
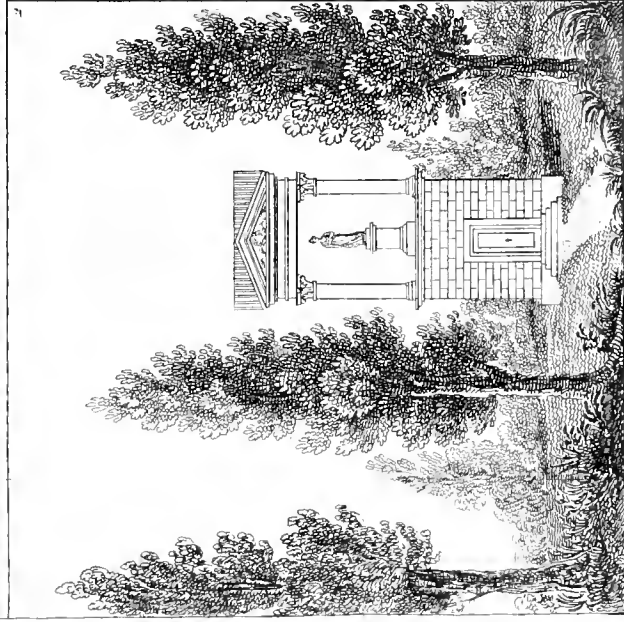






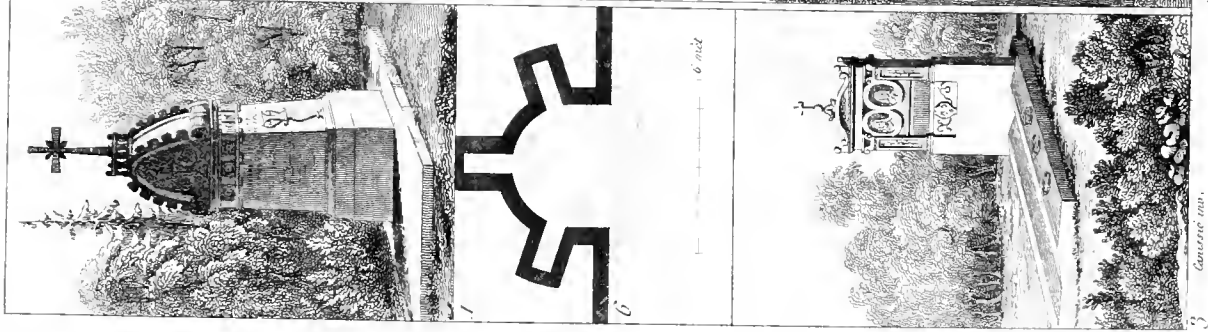
2.

1.

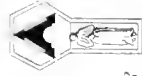
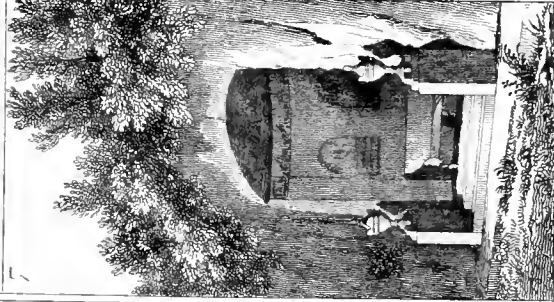
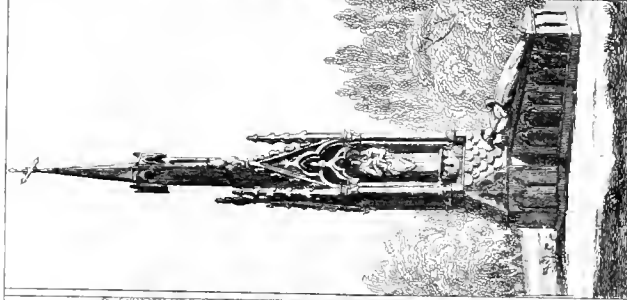


TOMBEAUX.

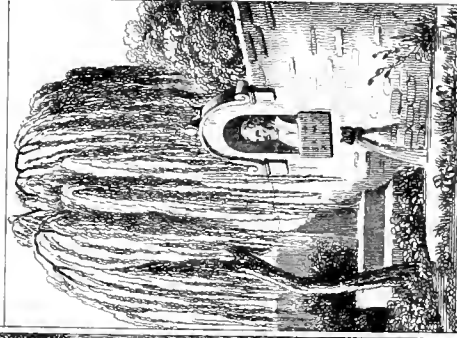
N. 129.



6. met.



6. met.

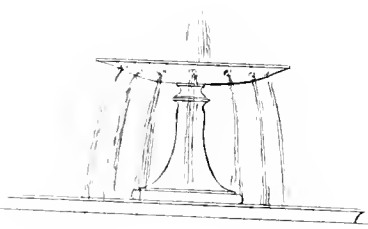


Paris 1810.

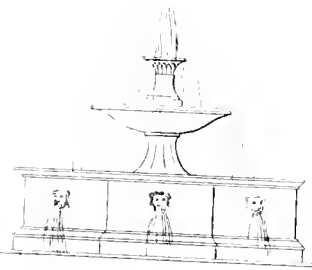


FONTAINES.

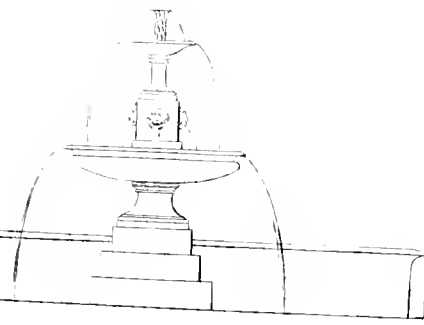
4



5



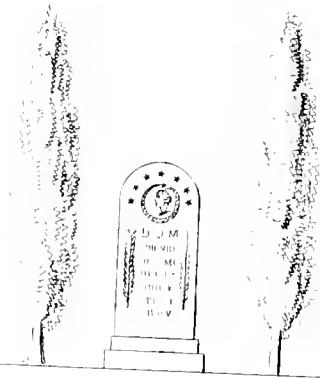
6



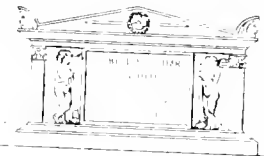
TOMBEAUX.

Pl. 30

1



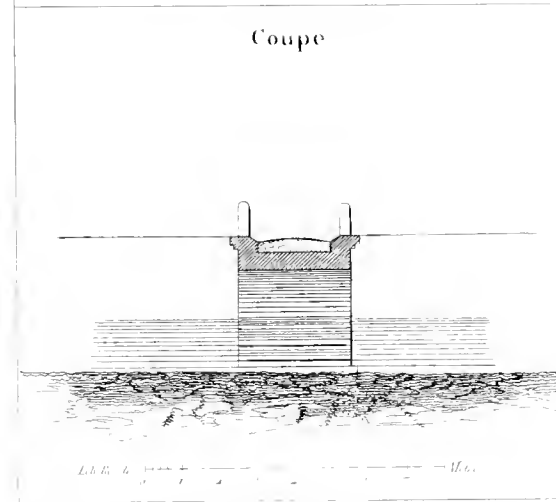
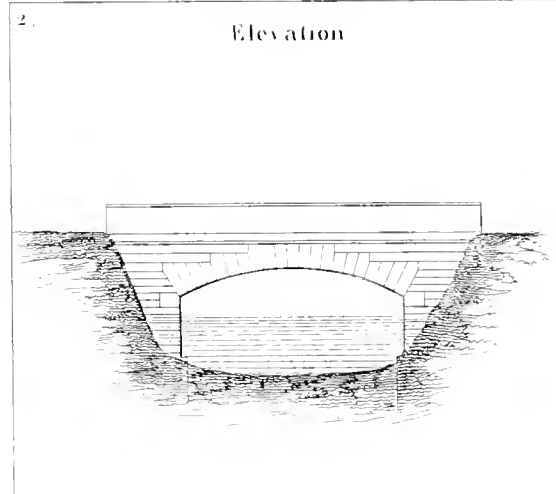
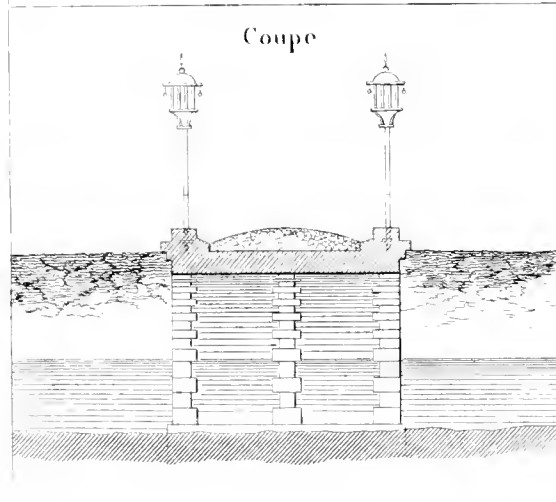
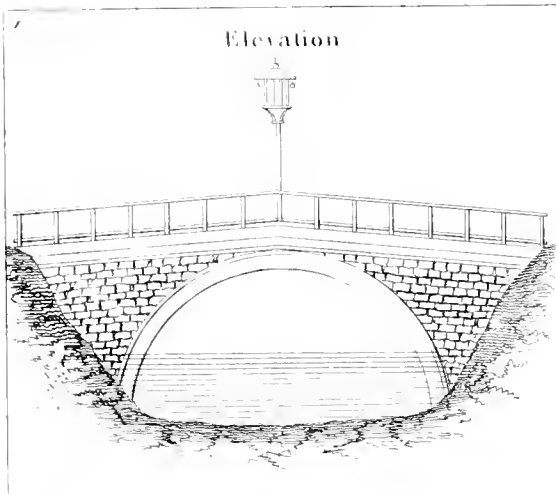
2



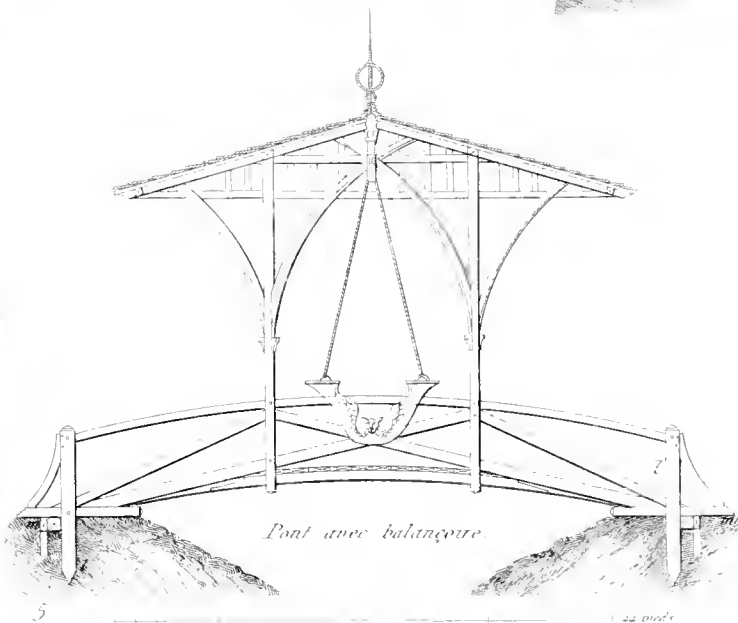
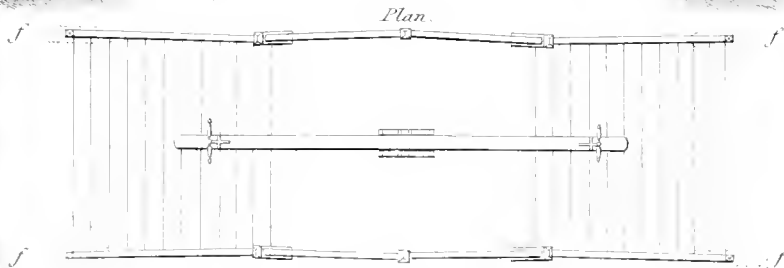
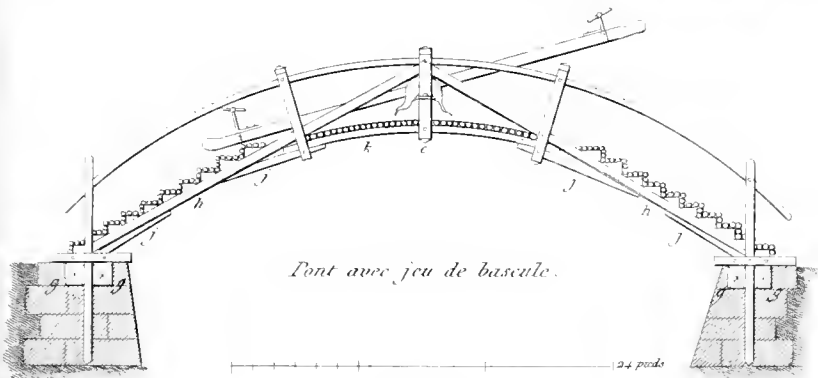
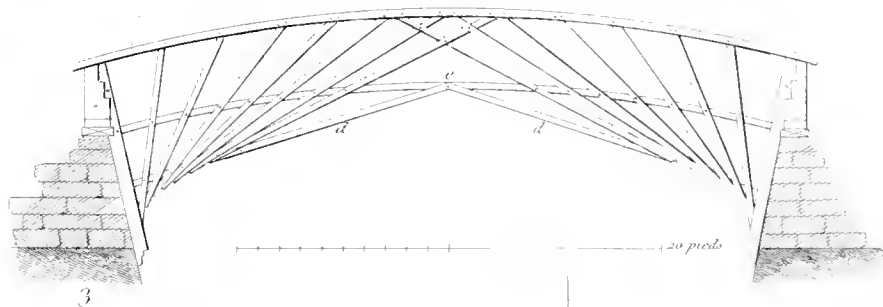
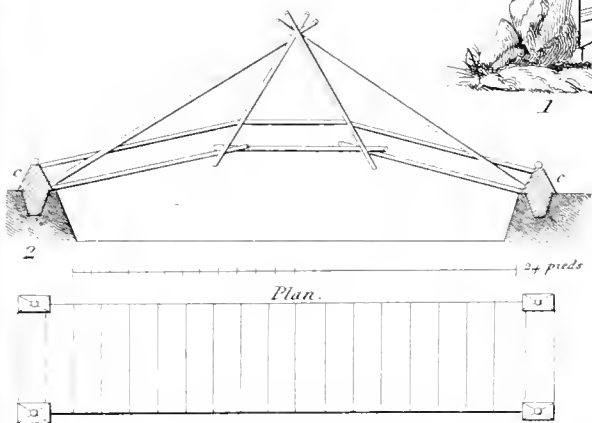
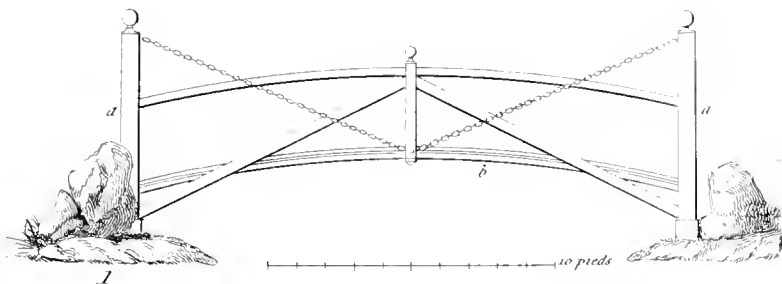
3



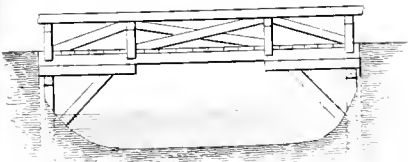




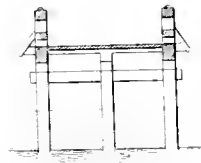




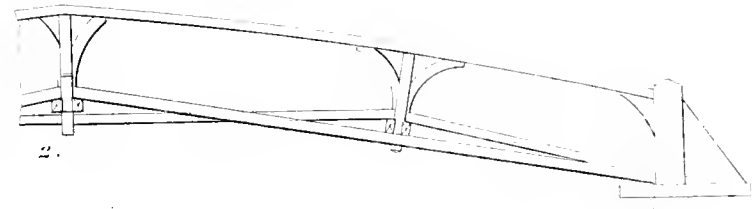




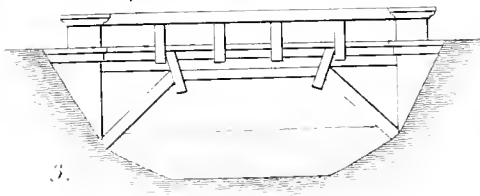
Coupe 3.



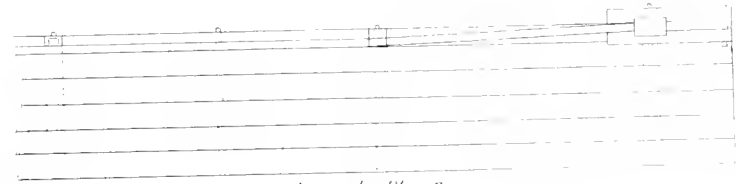
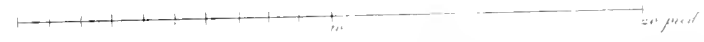
Coupe 3.



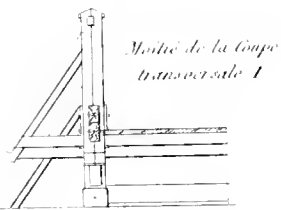
2.



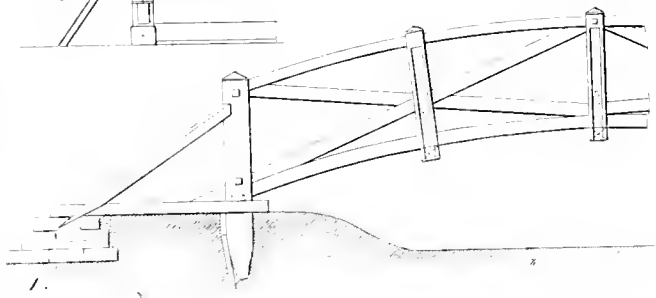
3.



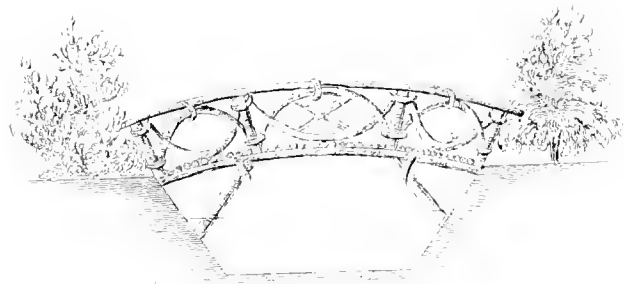
Quart du Plan 2



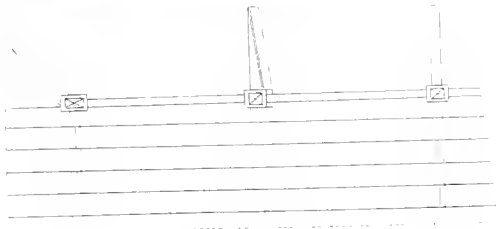
Montée de la coupe transversale 1



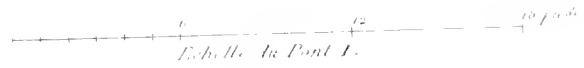
1.



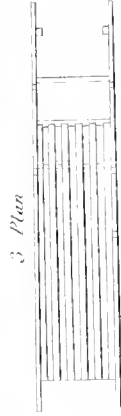
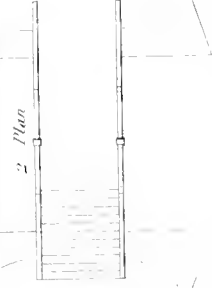
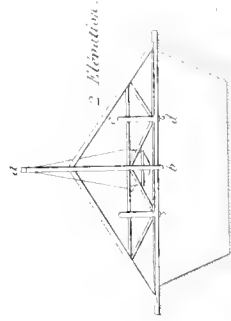
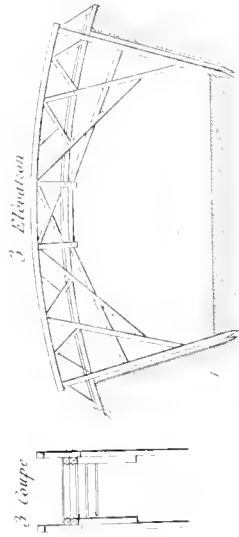
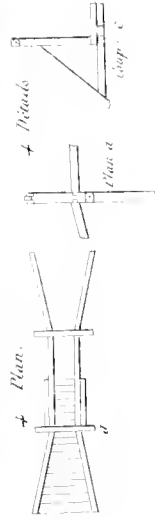
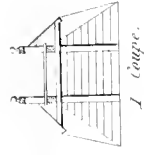
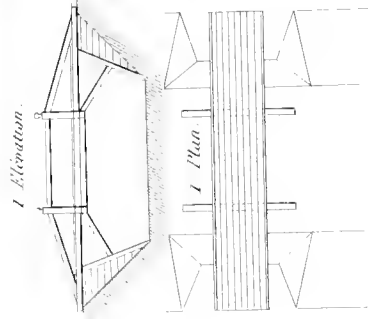
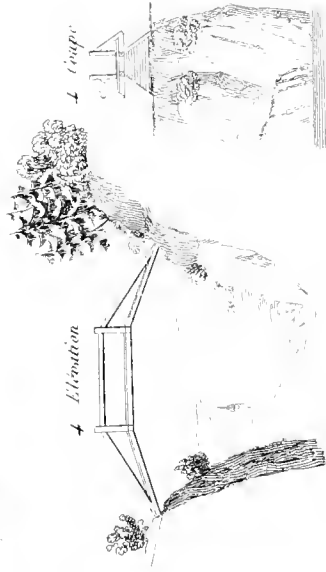
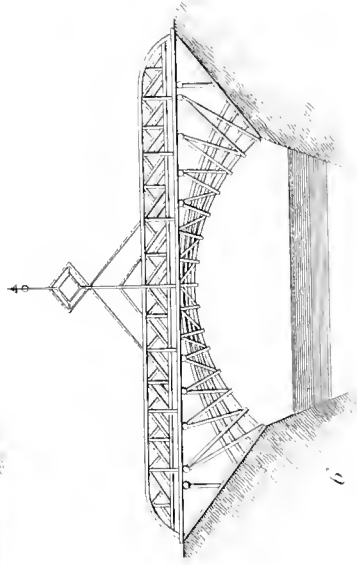
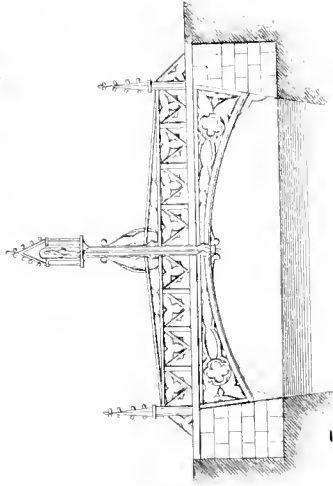
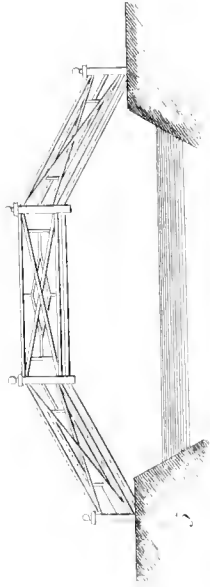
4.



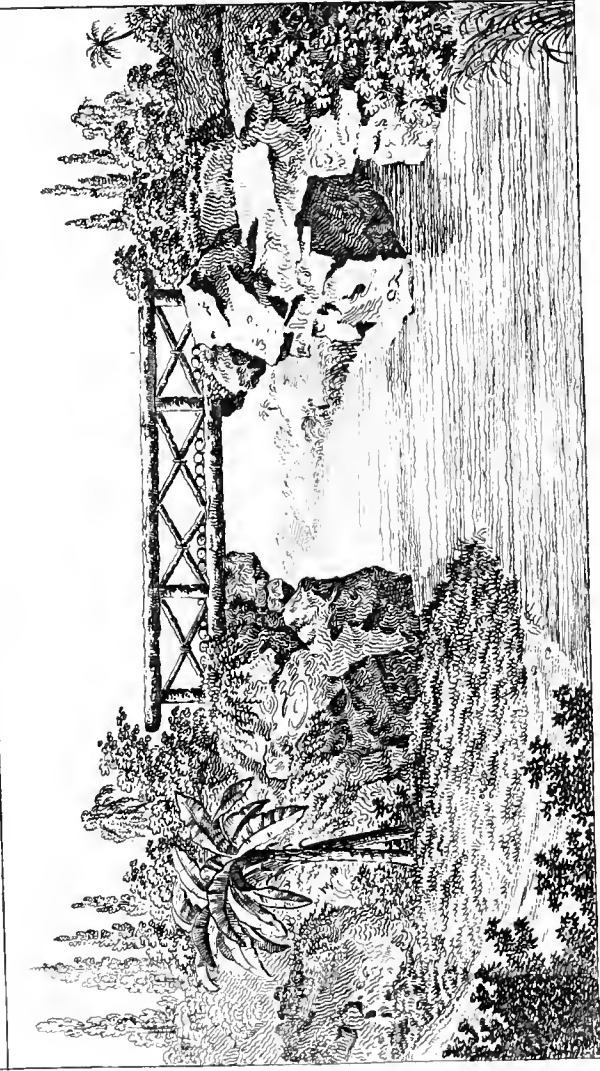
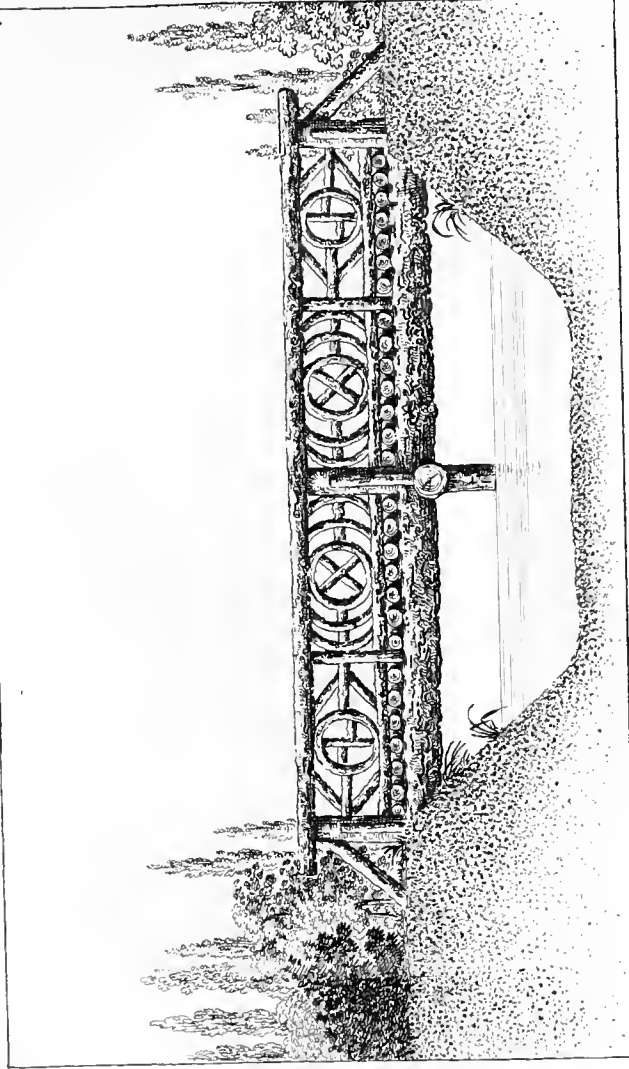
Quart du Plan 1

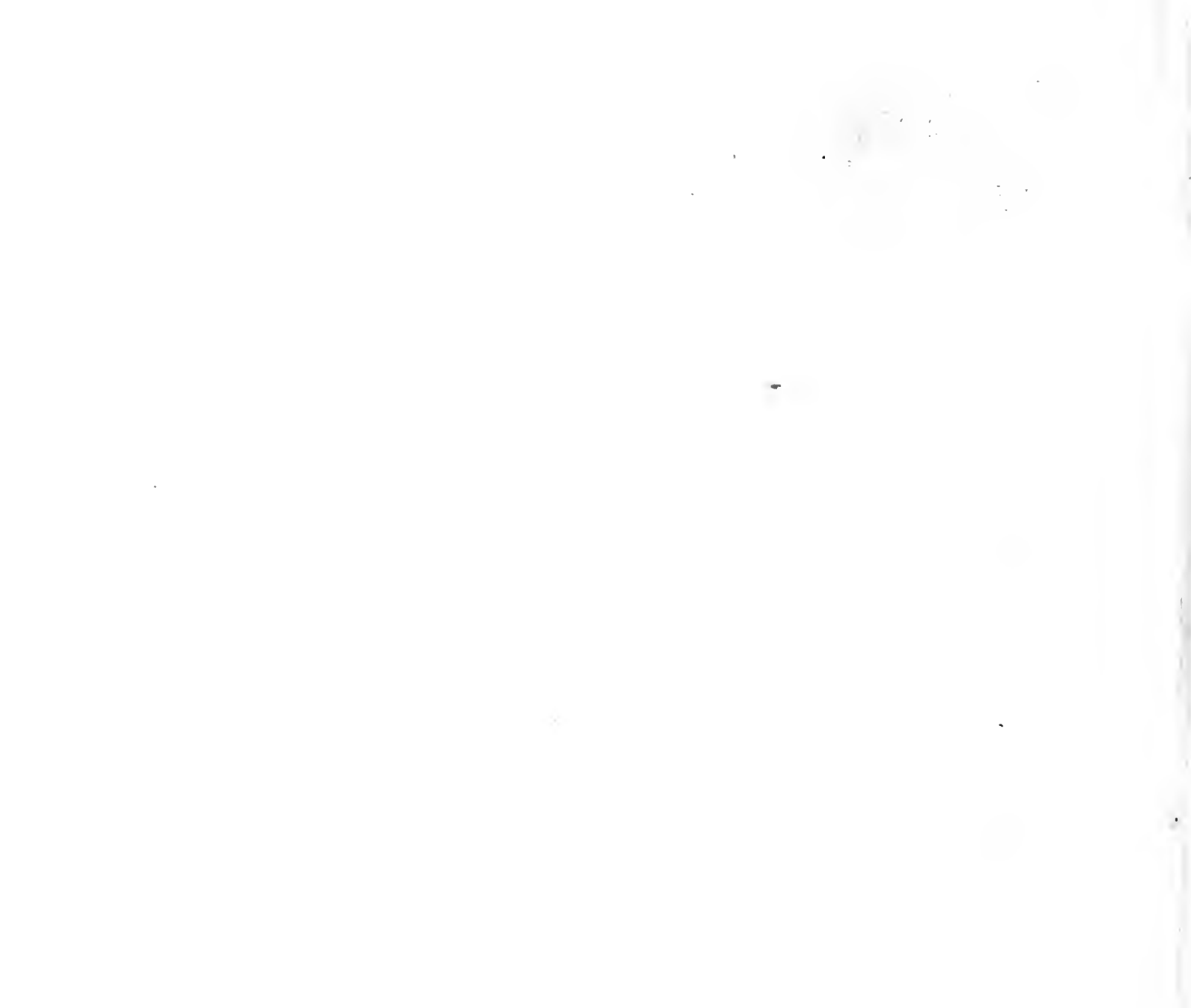


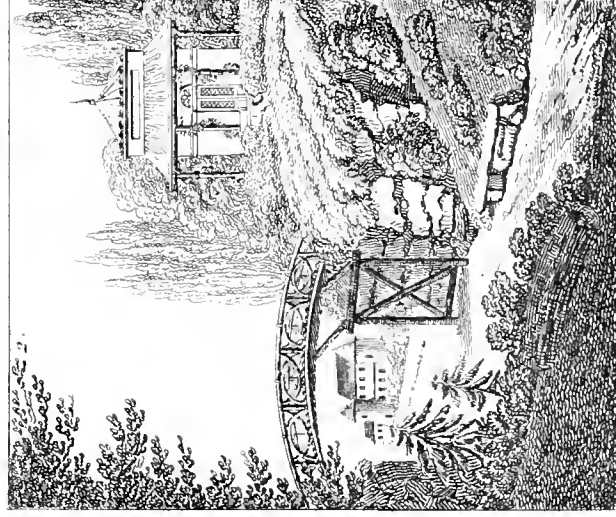
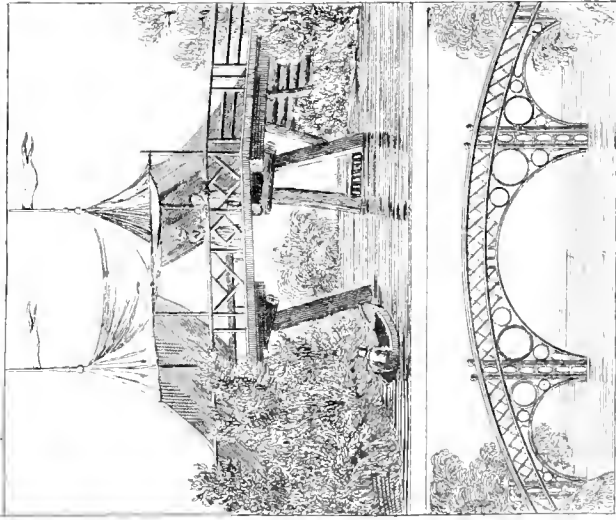
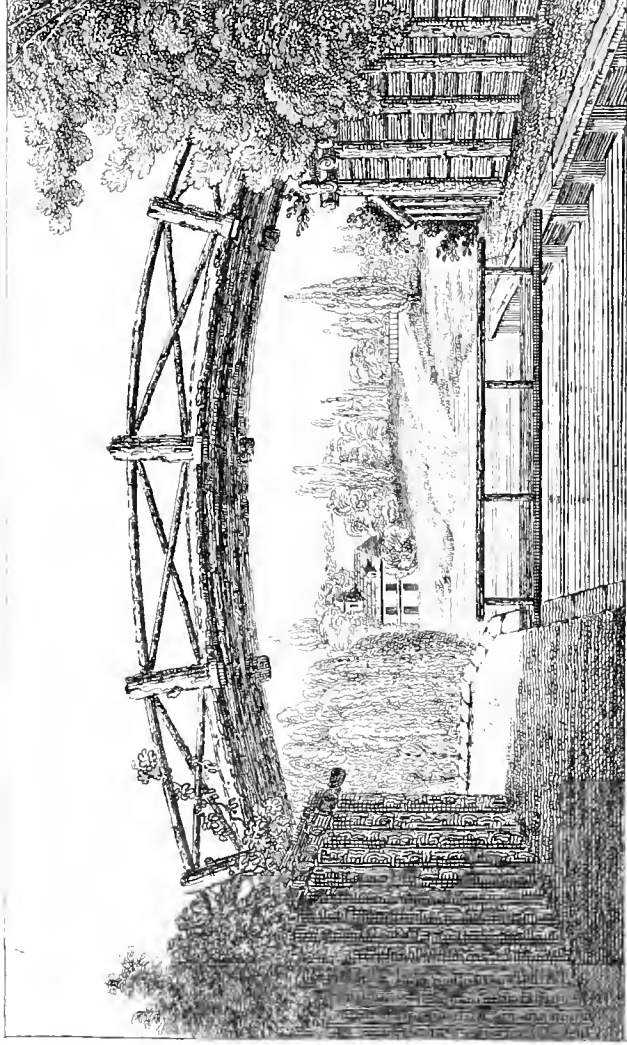
Echelle du Pont 4.





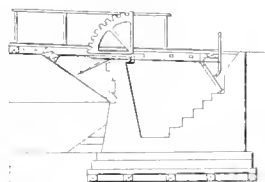




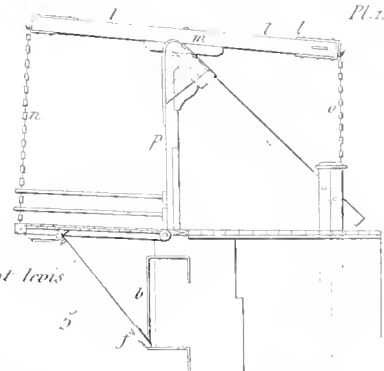




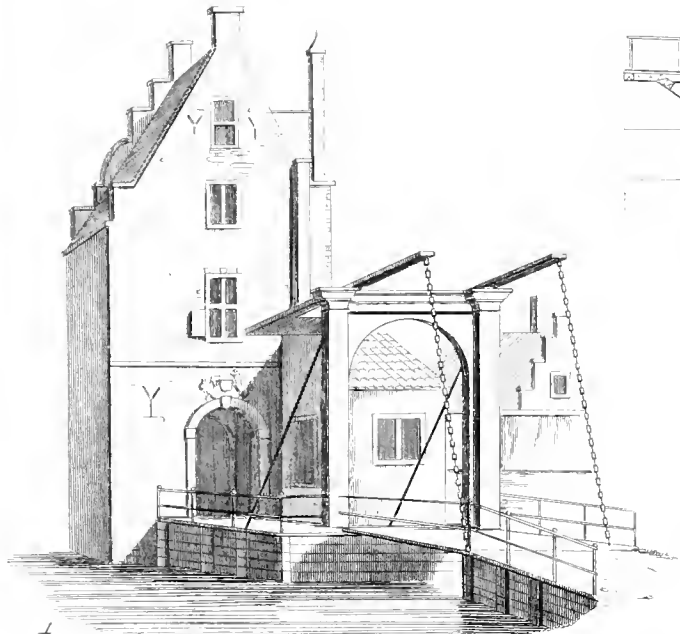
PONTS



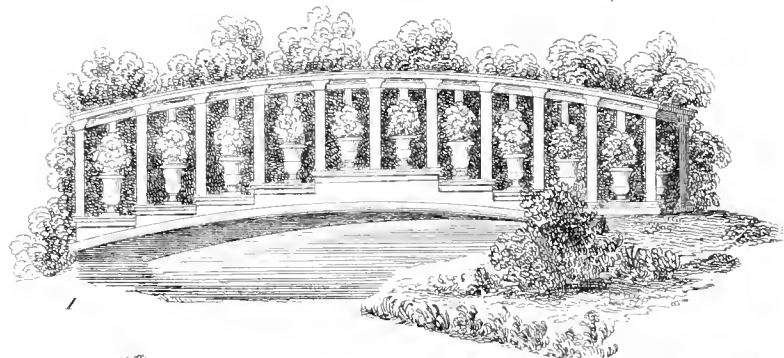
Pont à bascule



Pont levé



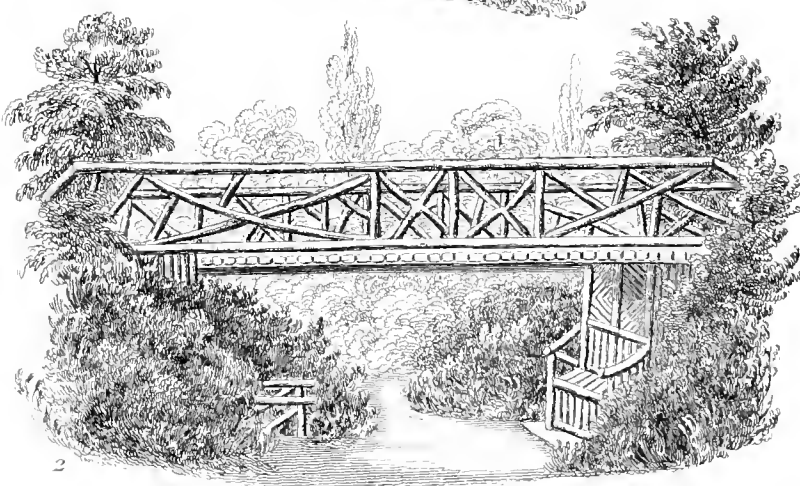
Pont levé hollandais.



1

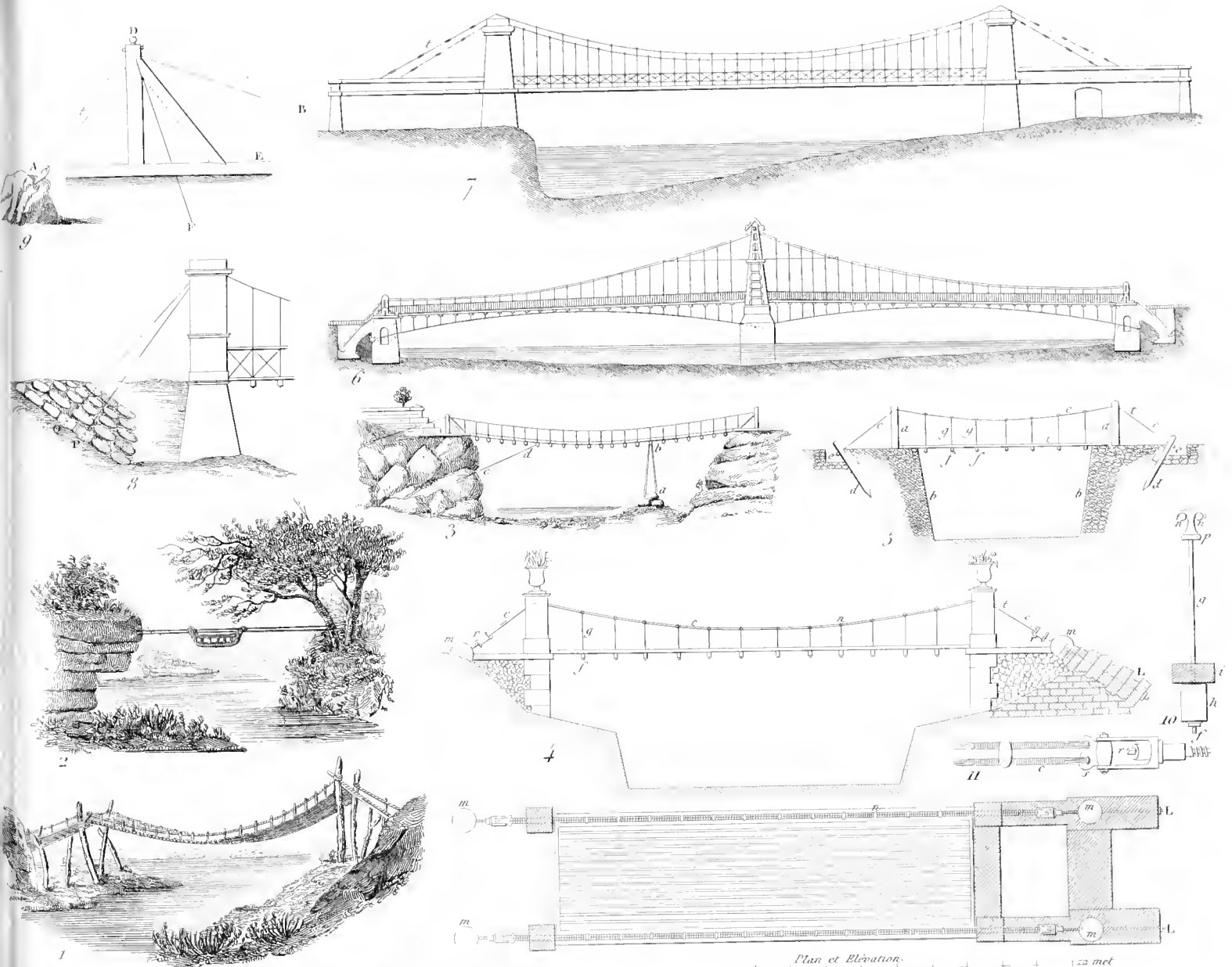


3



2





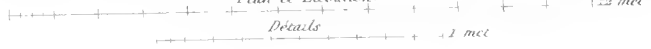
PONTS SUSPENDUS

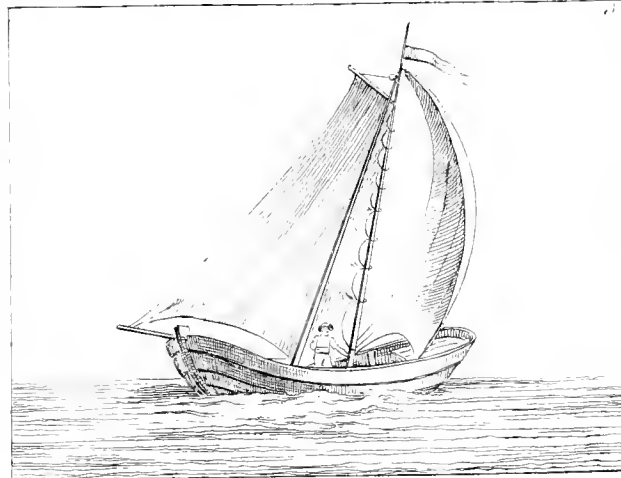
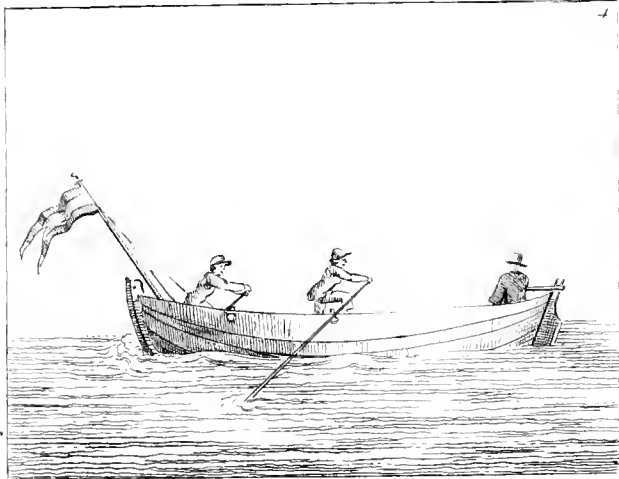
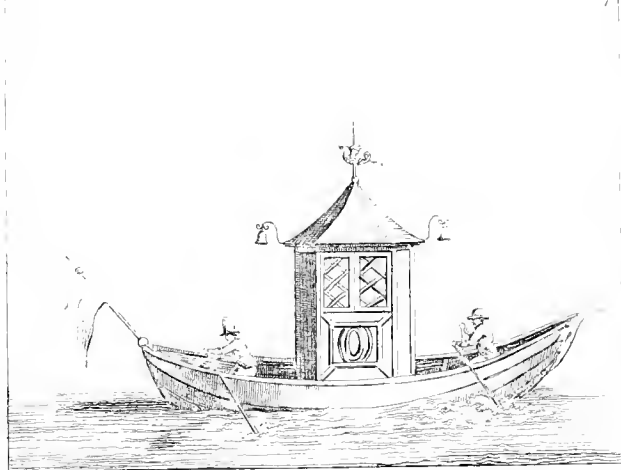
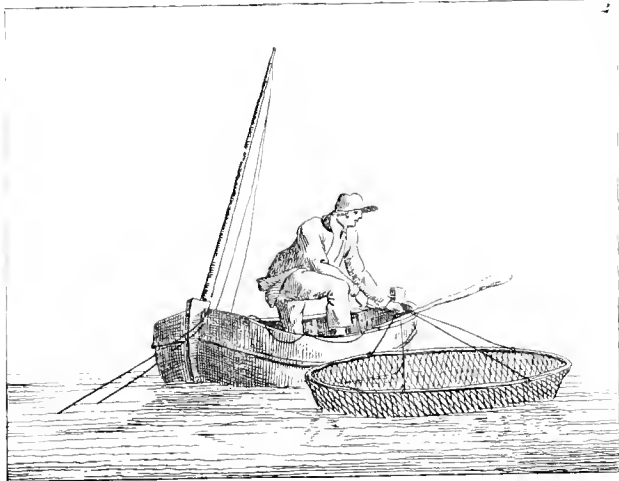
Plan et Elevation.

Détails

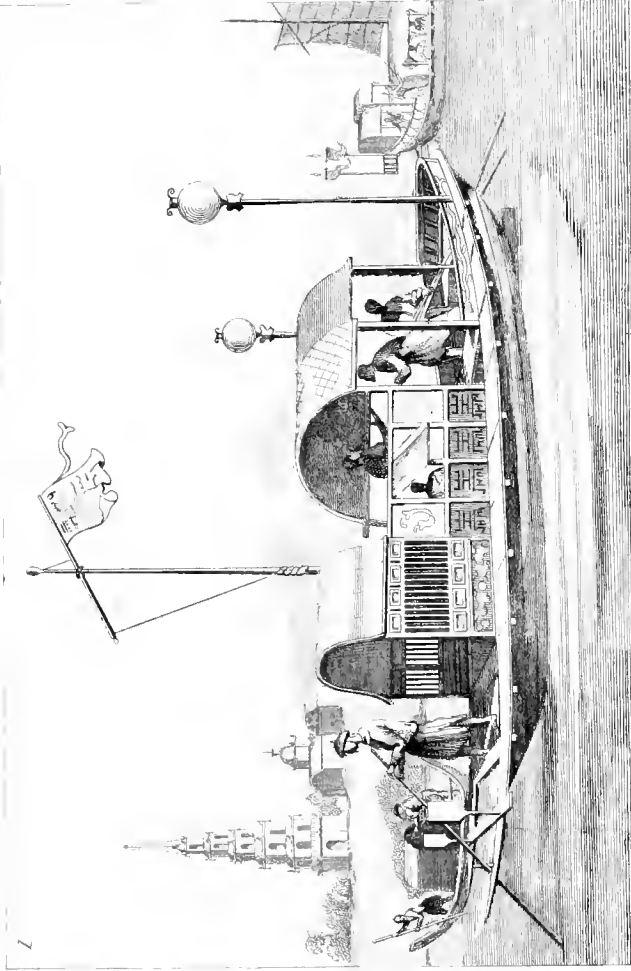
1/22 met

1 met



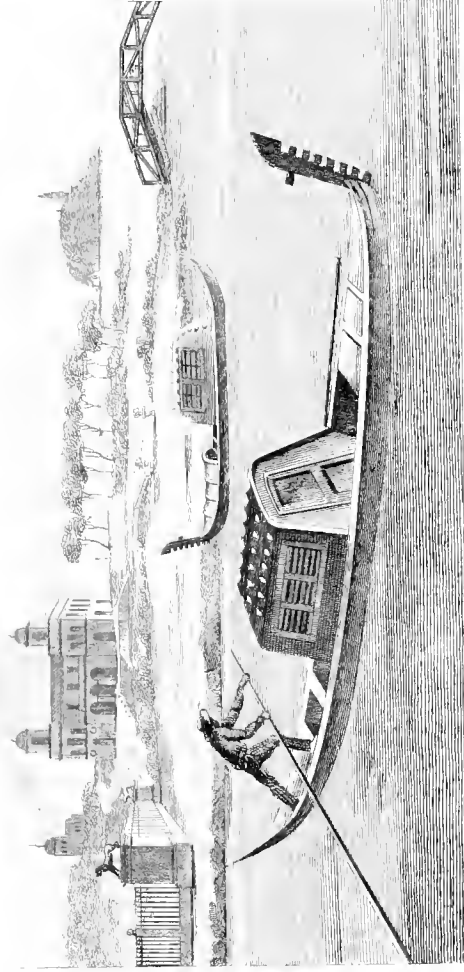






GONDOLE VENETIENNE.

2



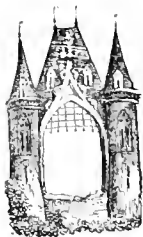
Canotto del

Parigi 55





8



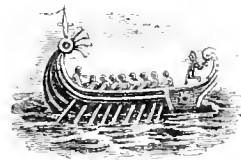
1



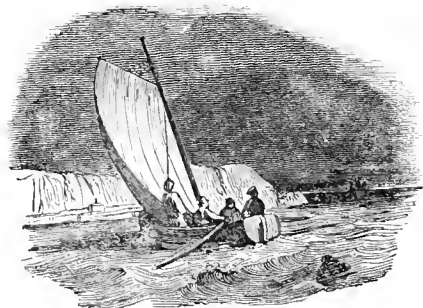
12



2



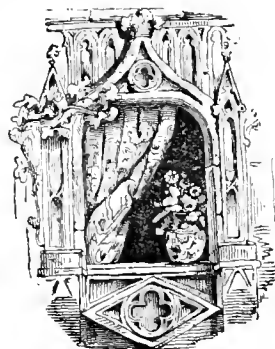
10



9



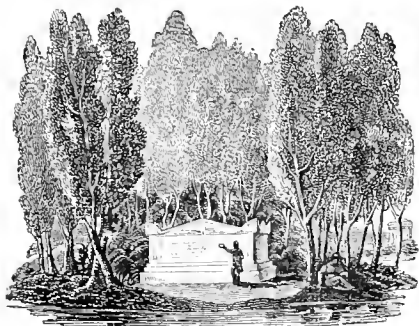
4



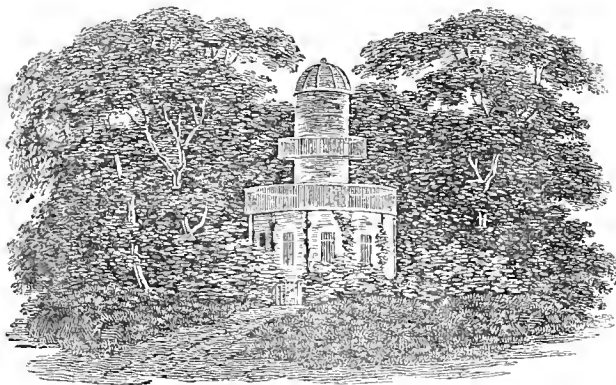
3



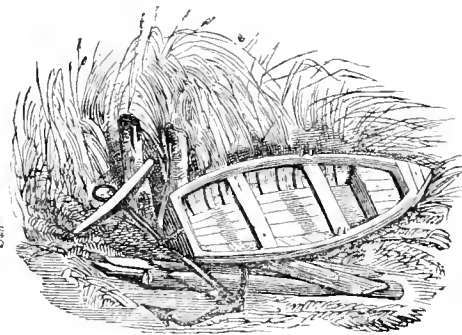
5



6

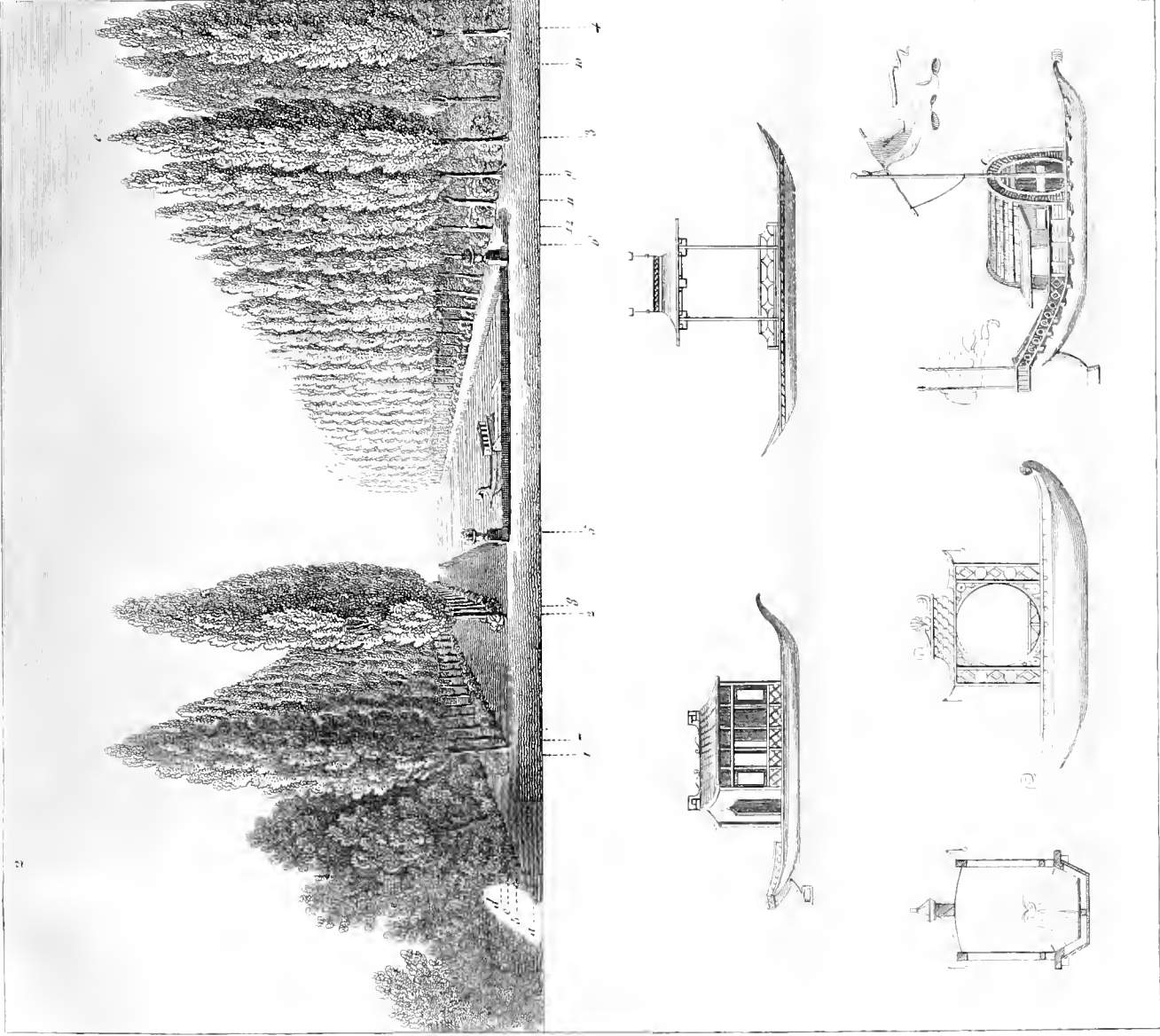


7



11

ÉGLISE. PORTES. FENÊTRES. PAVILLON. VASQUES. BARQUES. TOMBEAU.

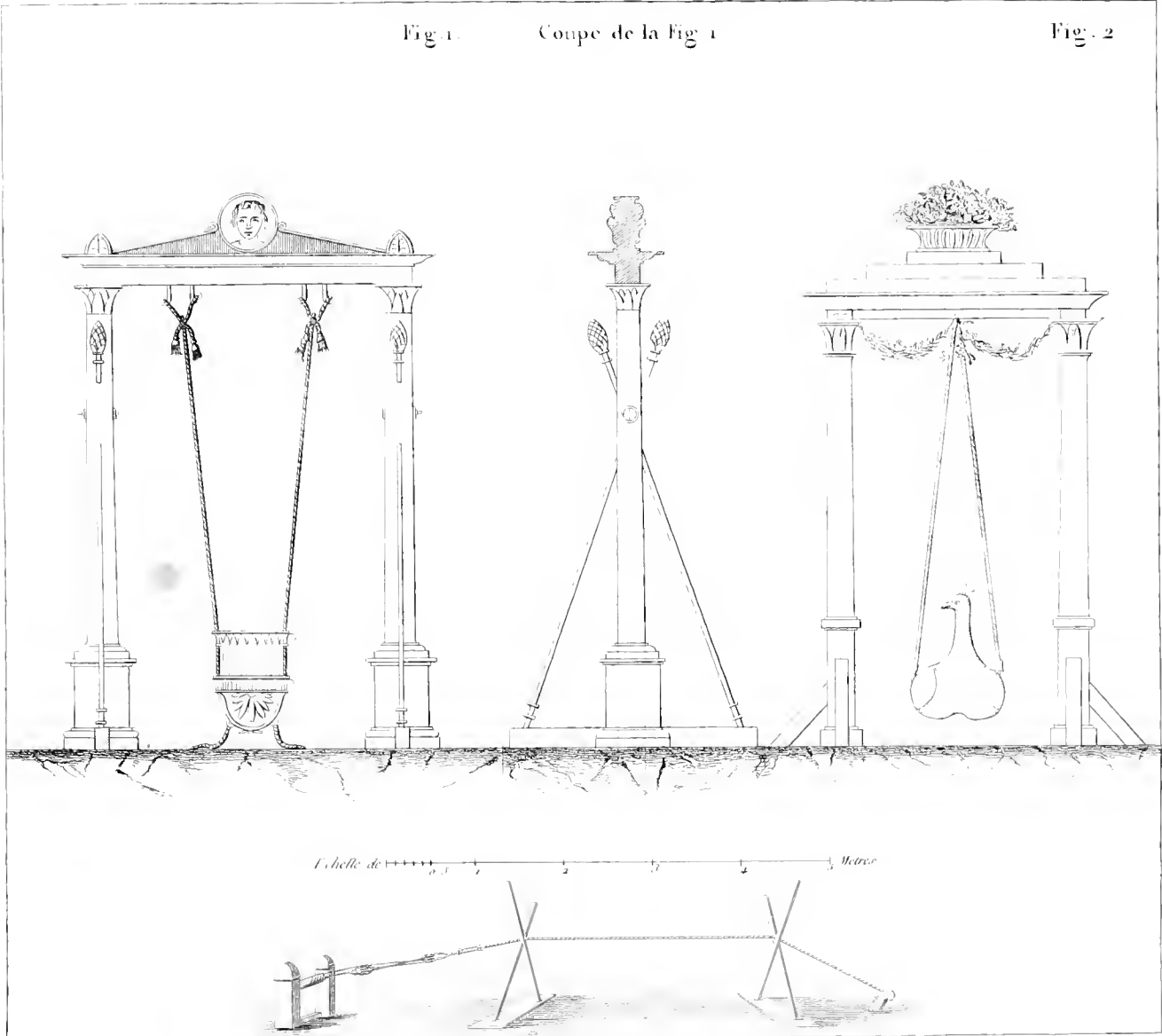


Barques et Jonques chinoises.

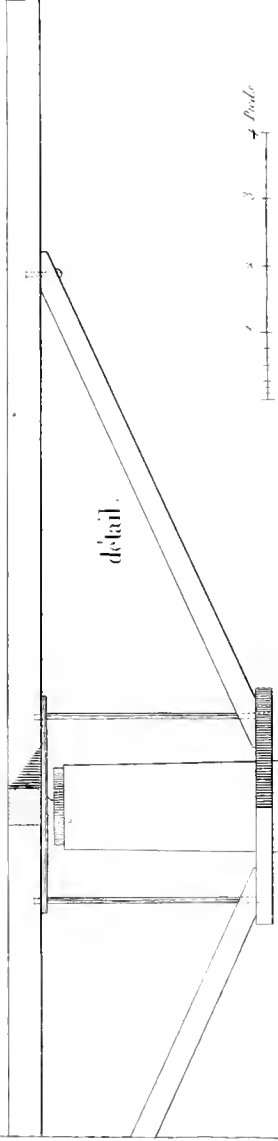
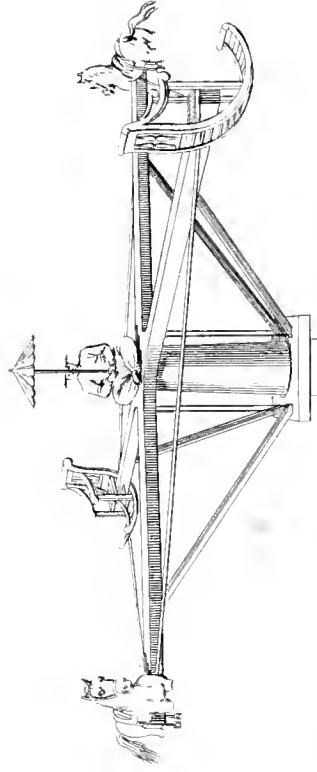


Fig. 1. Coupe de la Fig. 1

Fig. 2

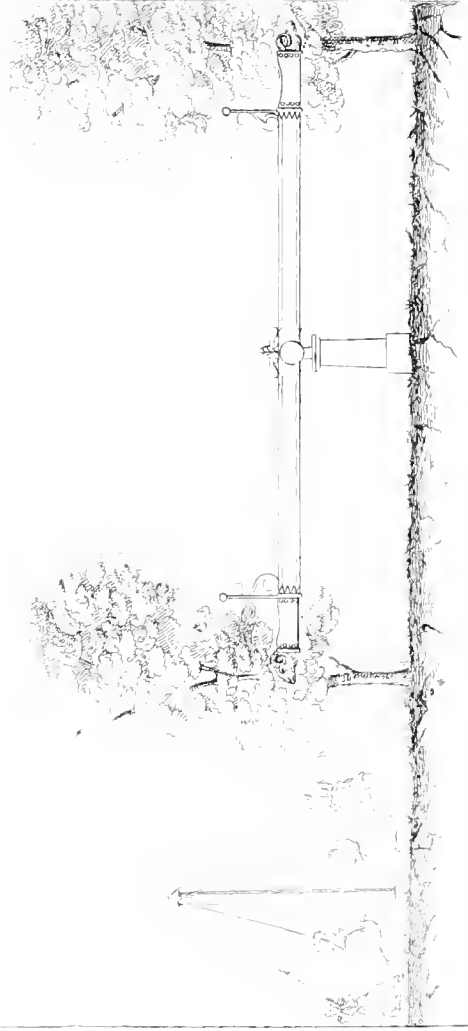




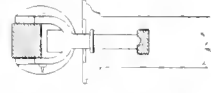


Empâchée des gants.

BASCULE.

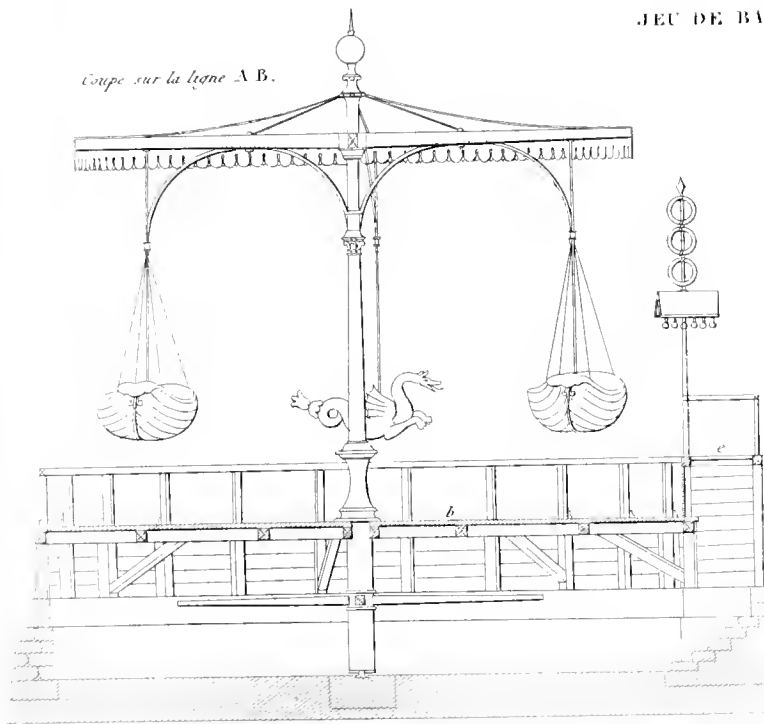


detail

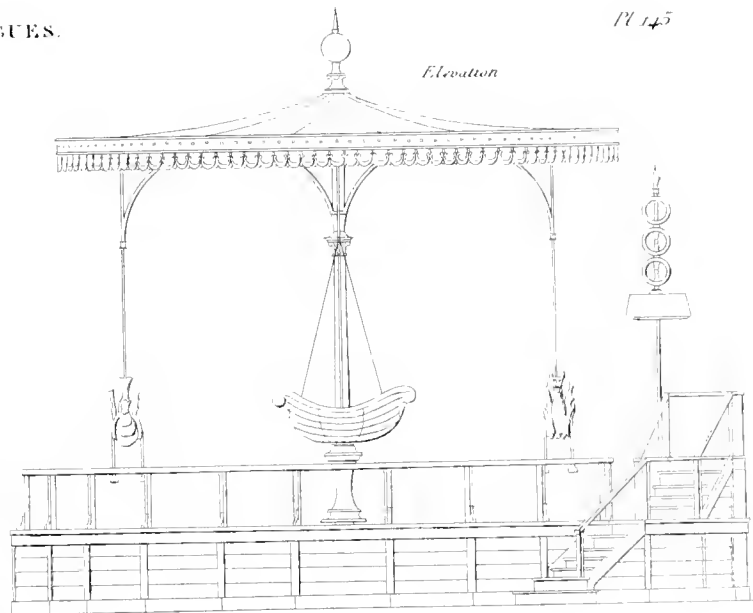




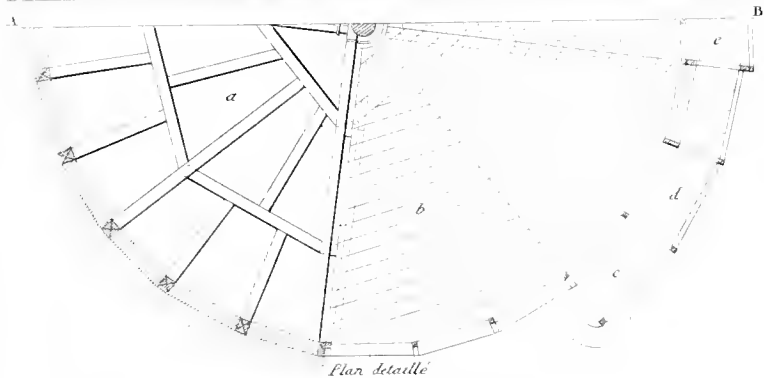
Coupe sur la ligne A B.



Elevation

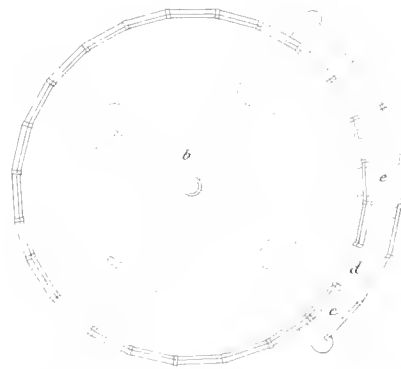


Plan



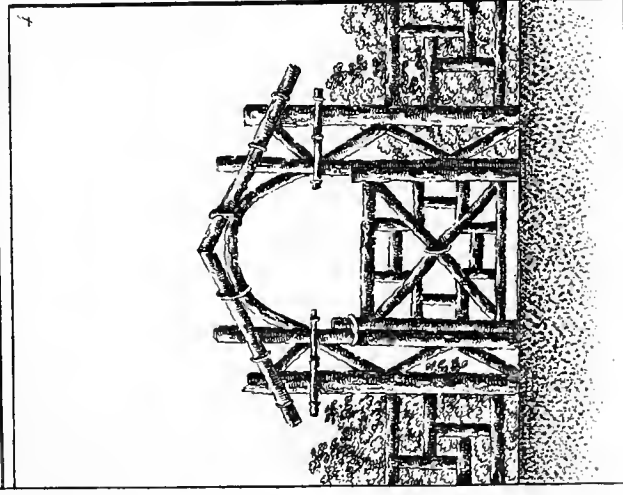
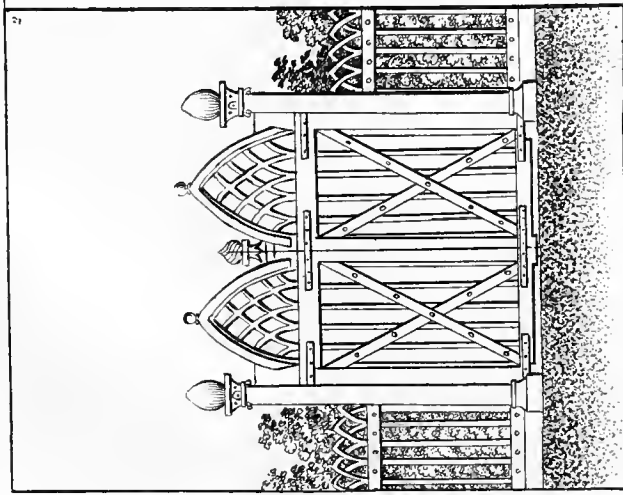
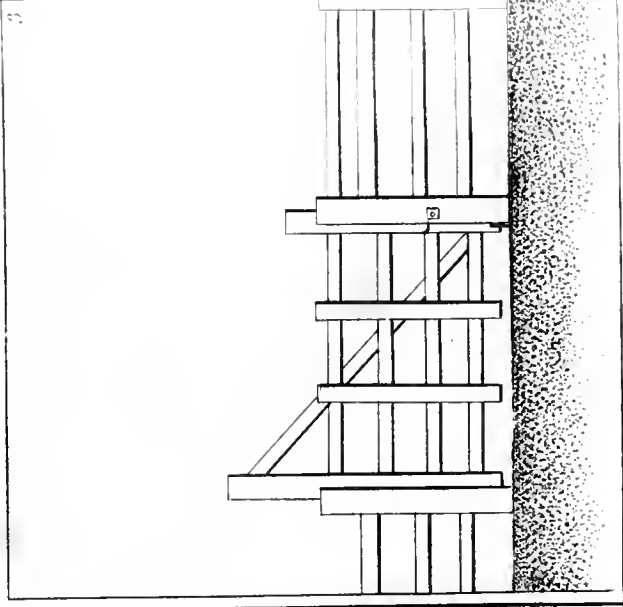
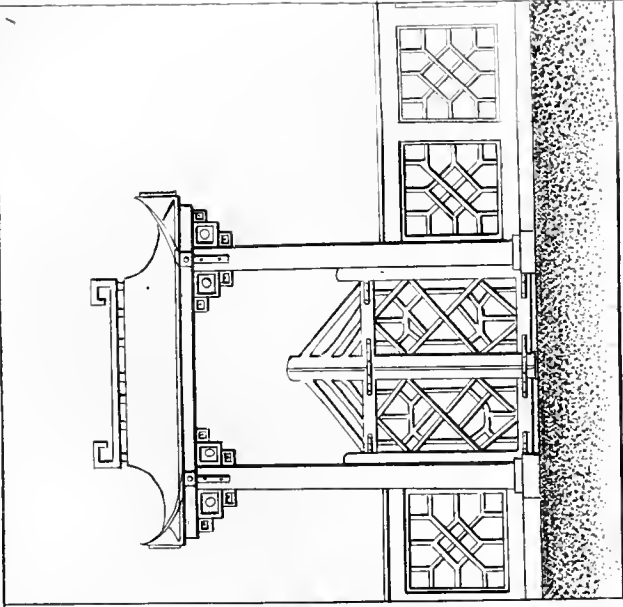
Plan détaillé

0 1 2 3 4 5 mètres

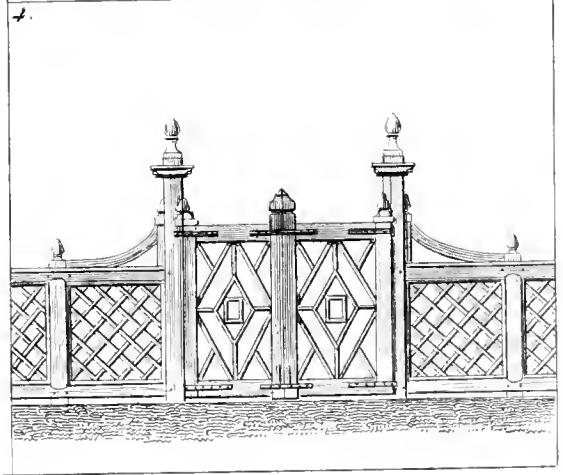
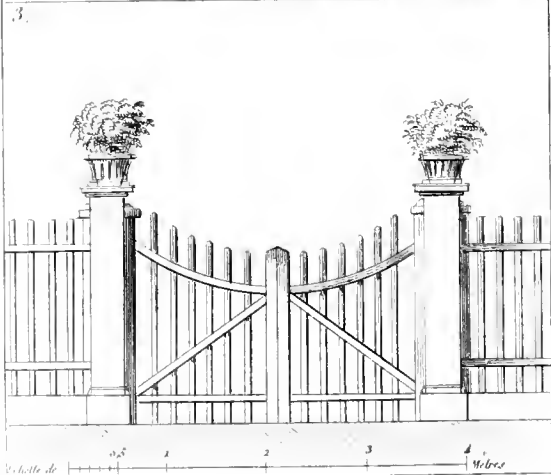
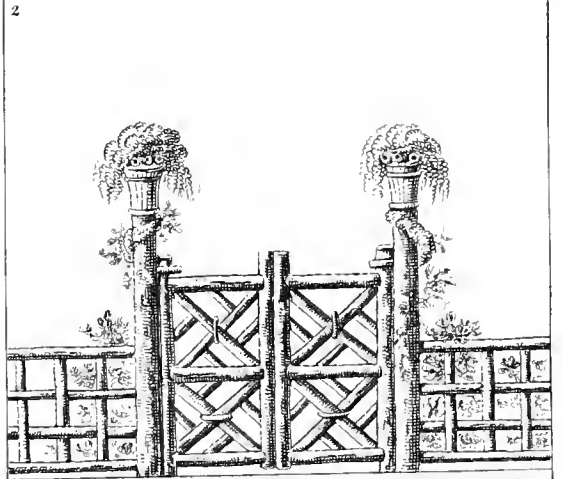
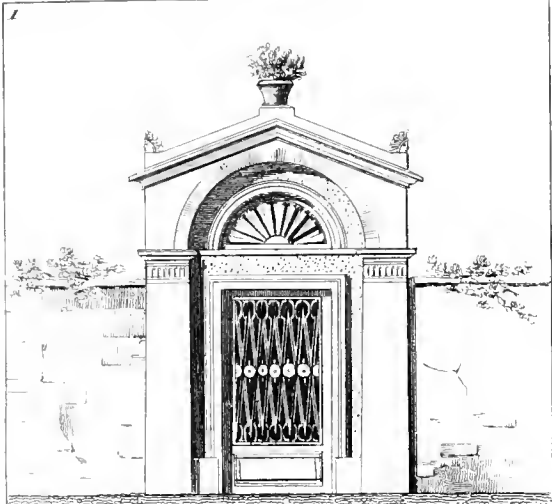


0 1 2 3 4 5 6 7 8 10 mètres Paris



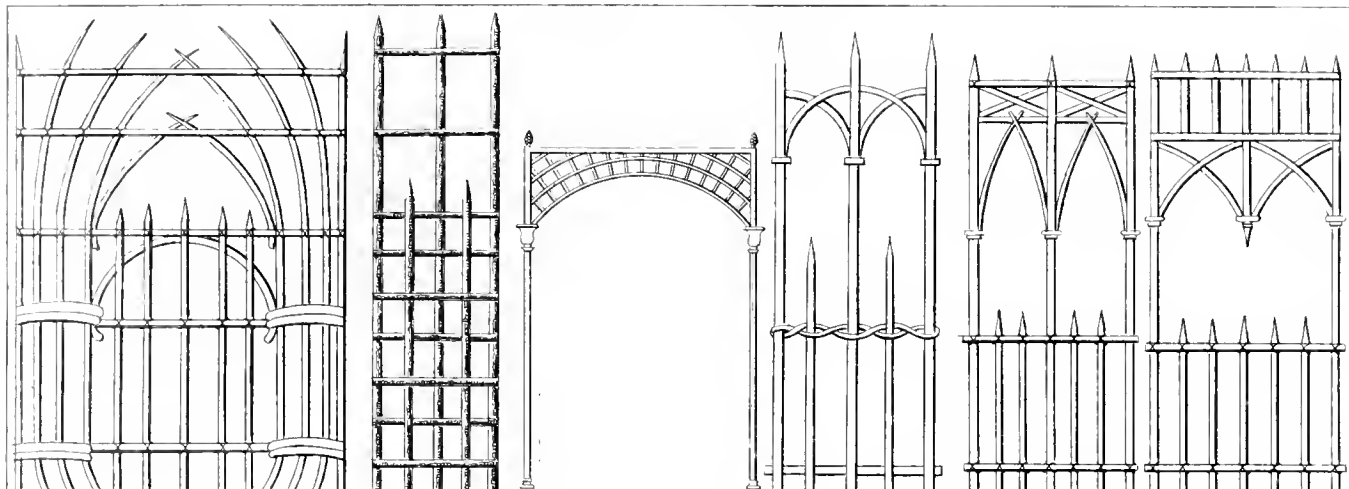




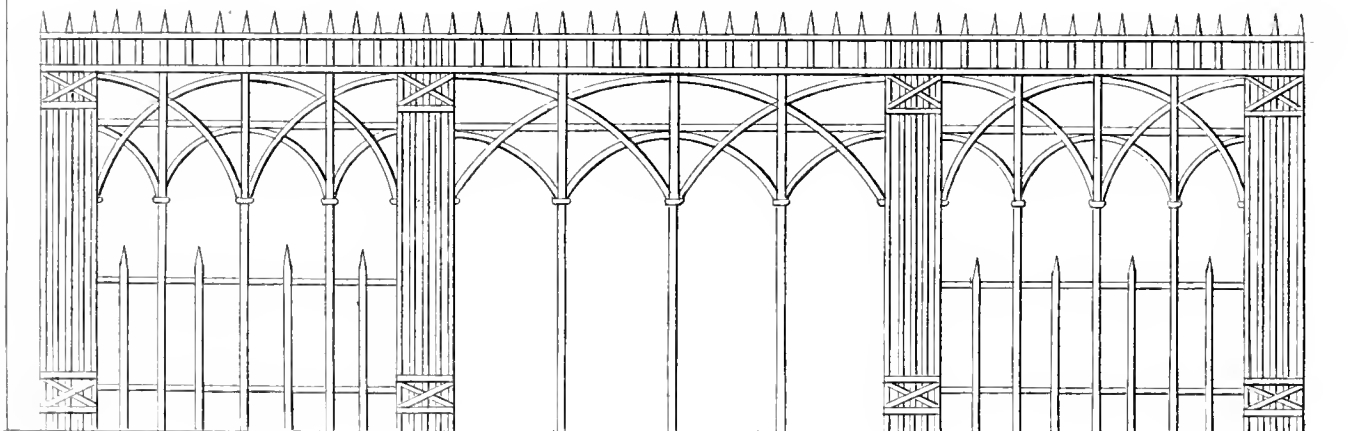


1/2 1 2 3 4
 Echelle de 1/2 toise

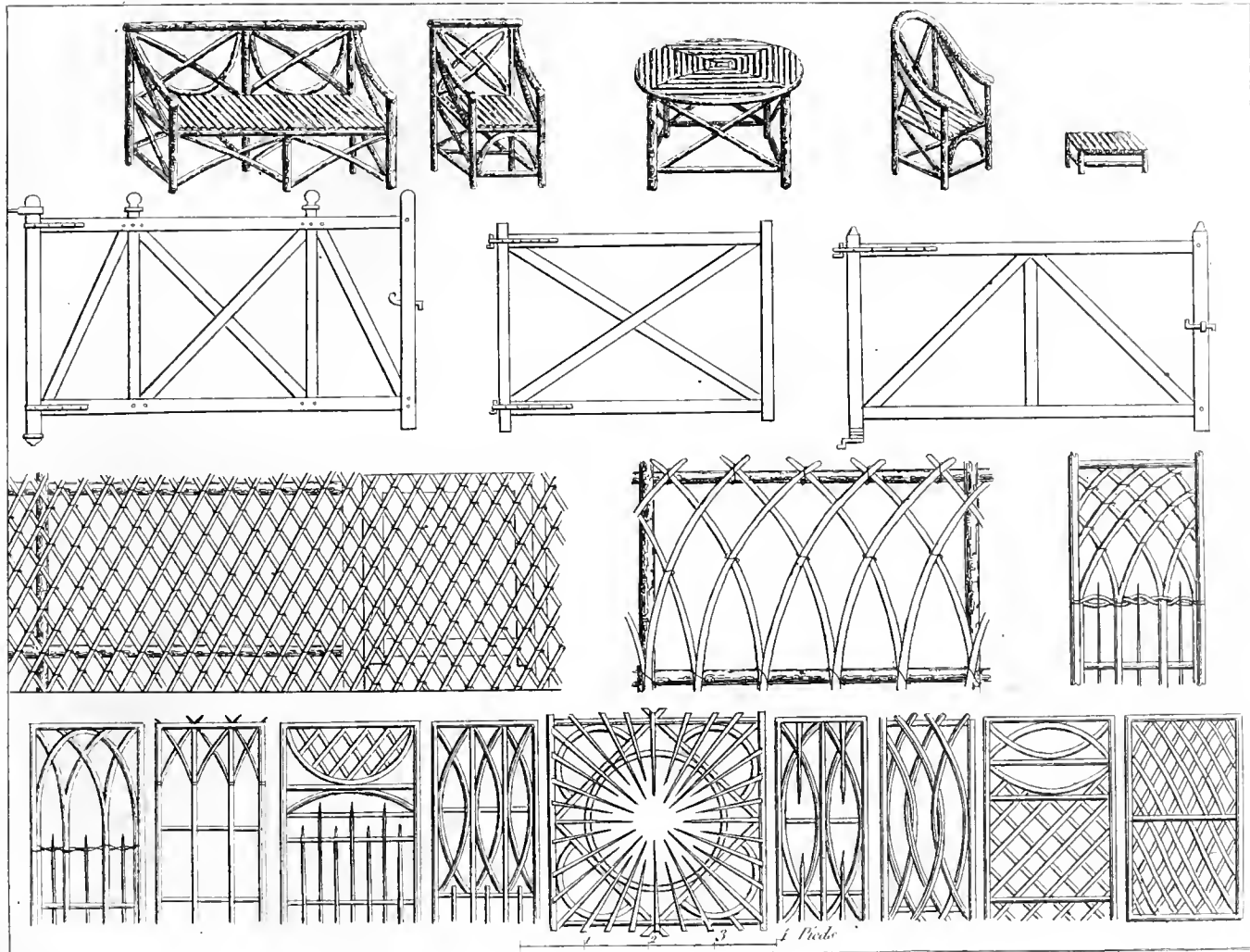




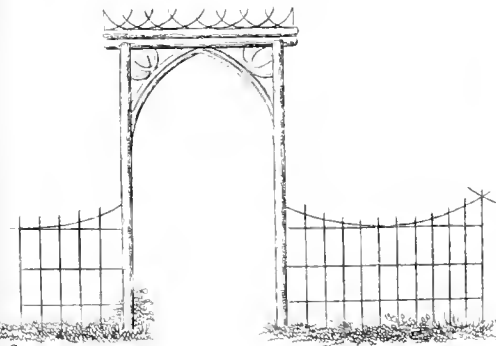
1 2 3 4 5 = 6 7 8 Pieds.



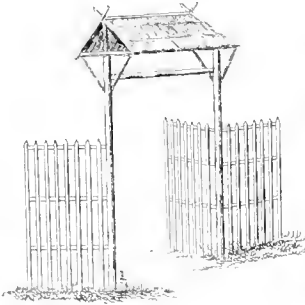




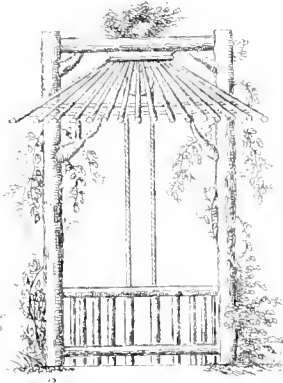




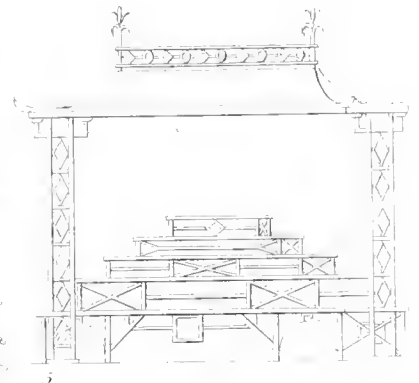
3



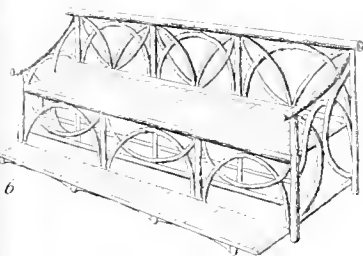
4



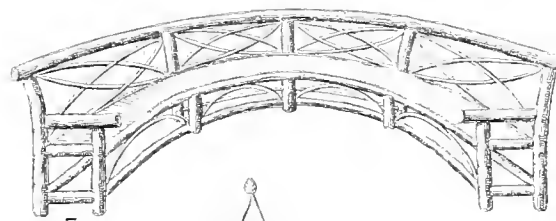
13



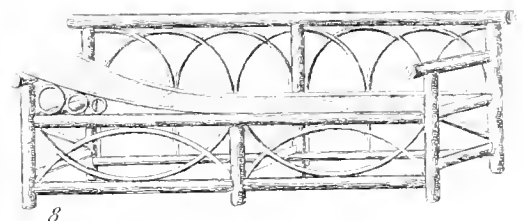
5



6



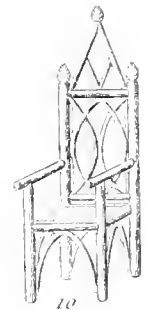
7



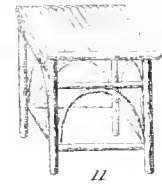
8



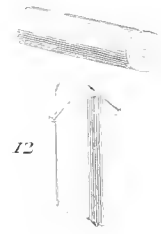
9



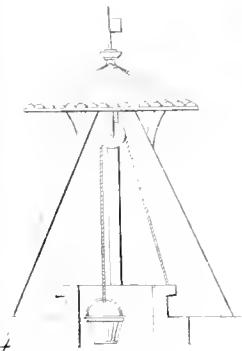
10



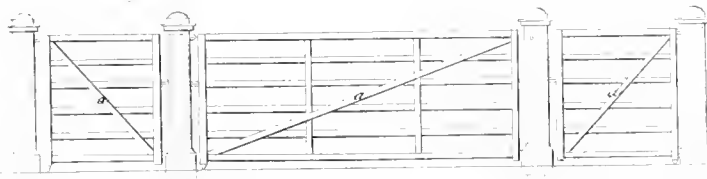
11



12



14



1



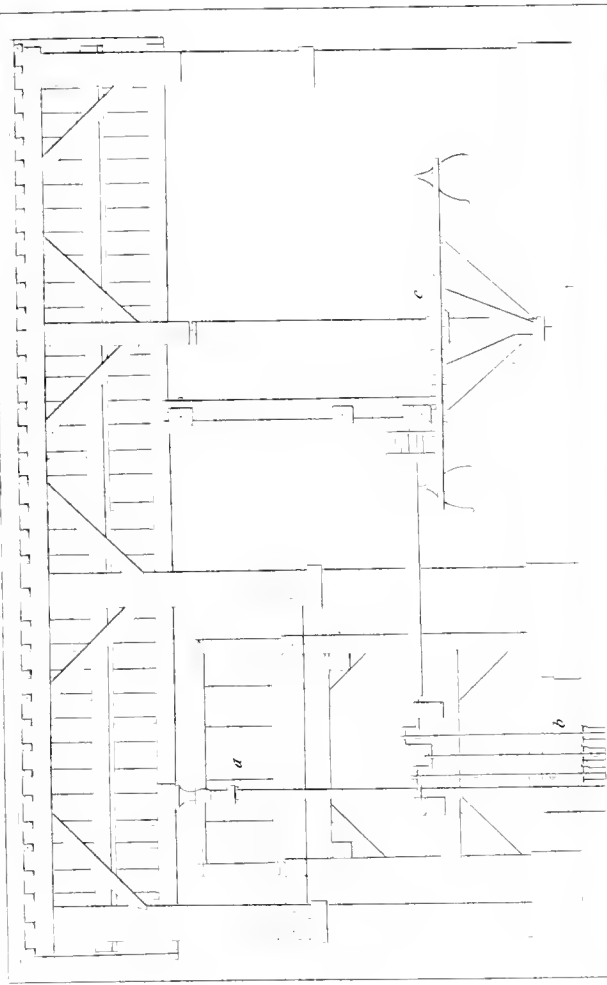
2

15



MANÈGE, POUR ÉLÉVER L'EAU.
Coupe longitudinale. Fig. 1.

Pl. LII.



10 mètres.

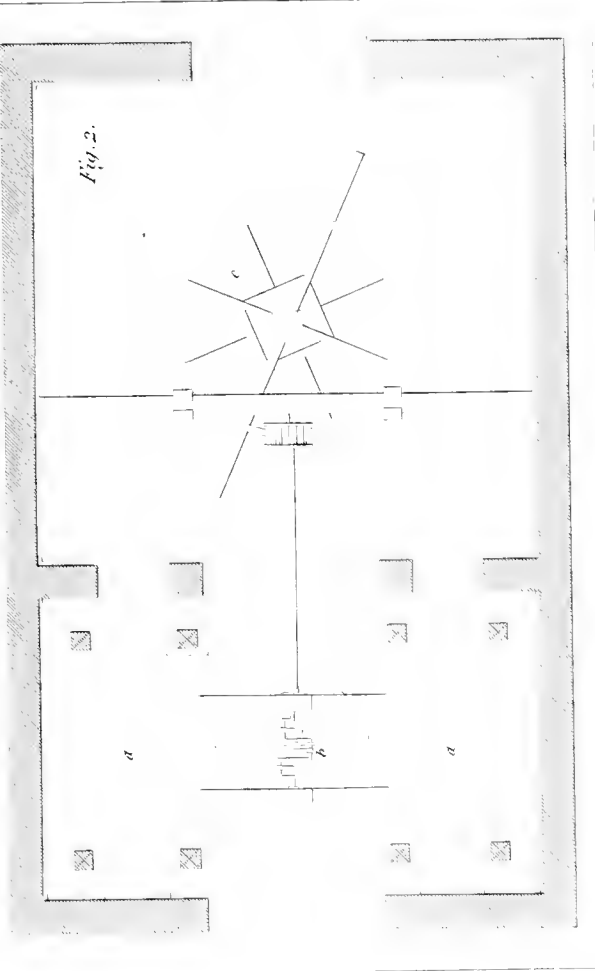
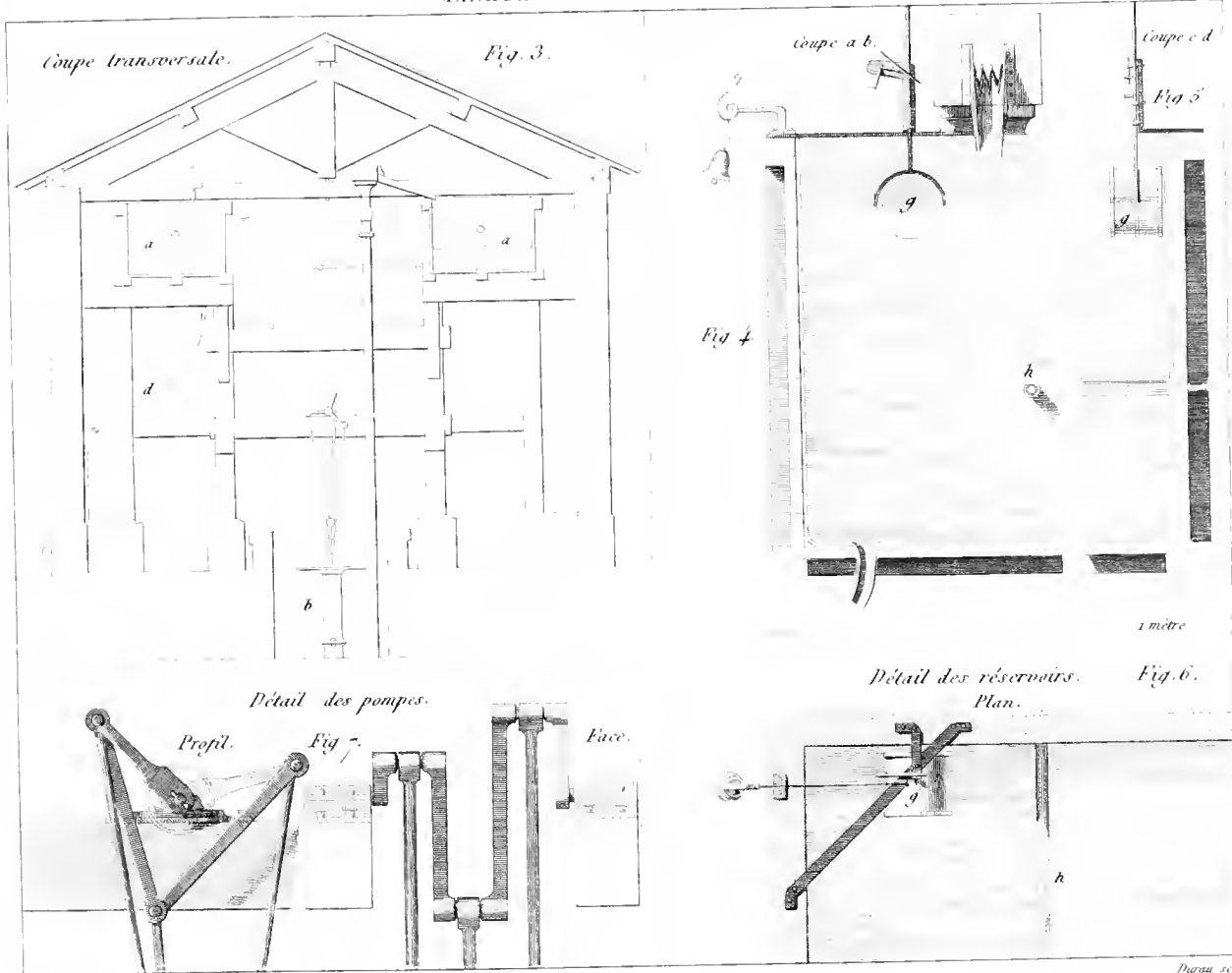


Fig. 2.

Parau 2.

Canson del.



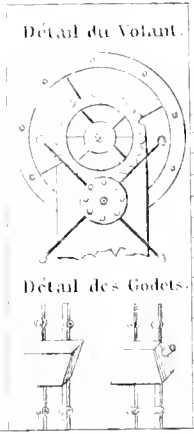
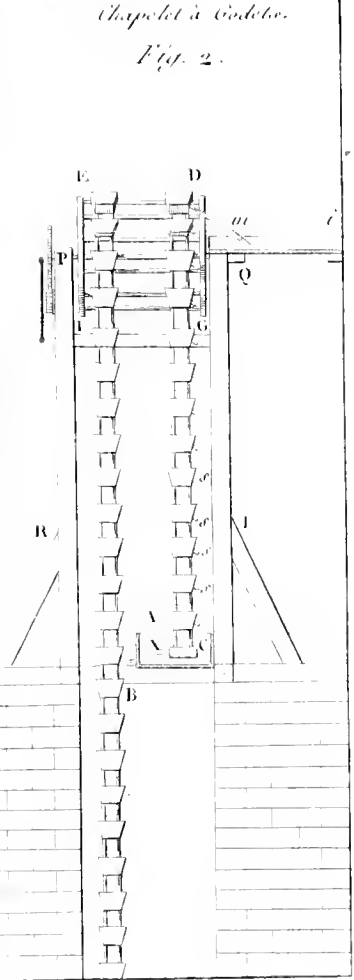
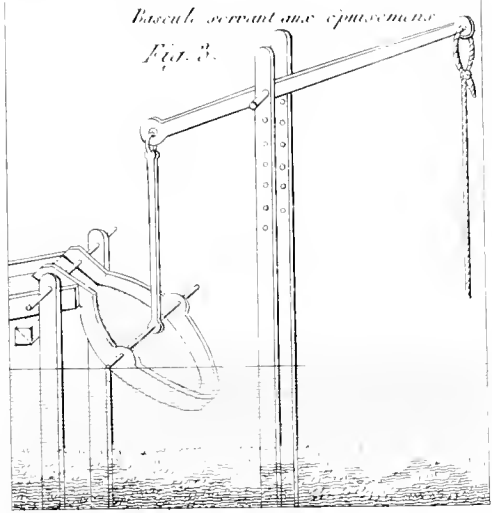
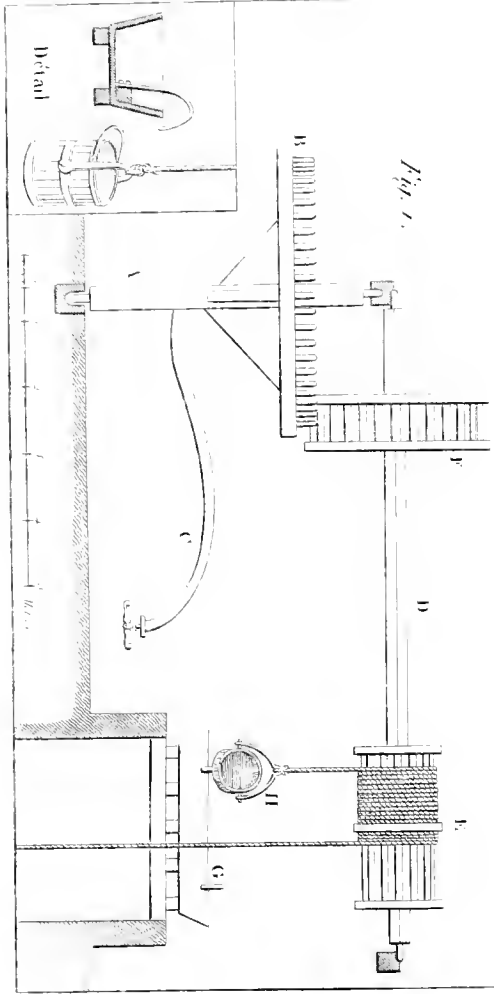


Canasse del

Dureau sc



Fontaine pour élever l'eau





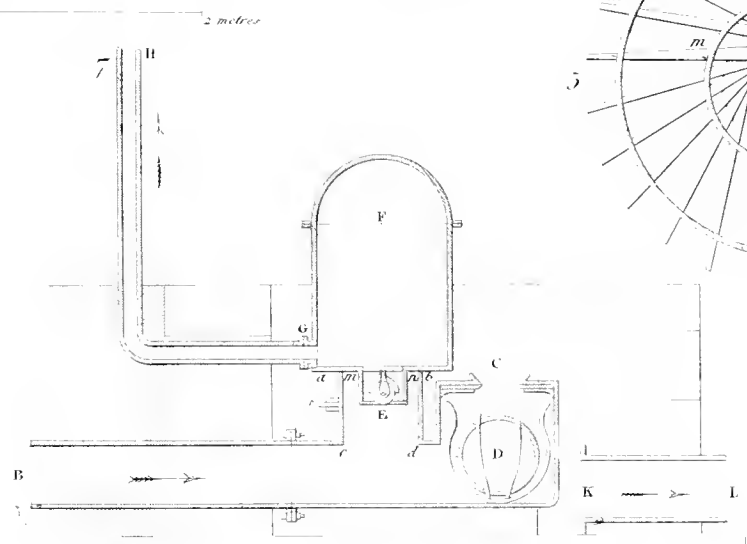
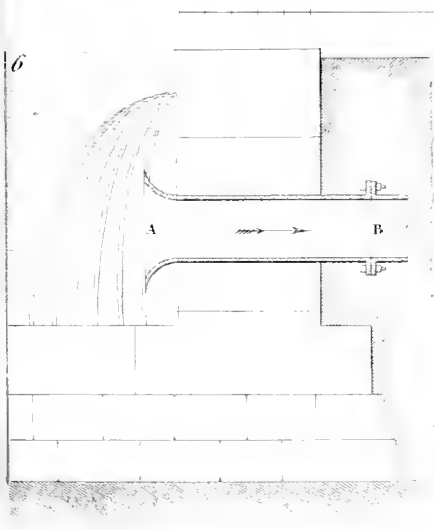
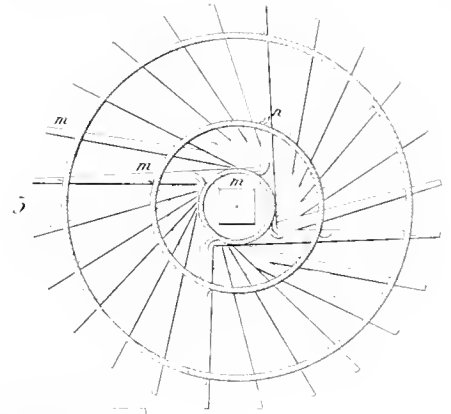
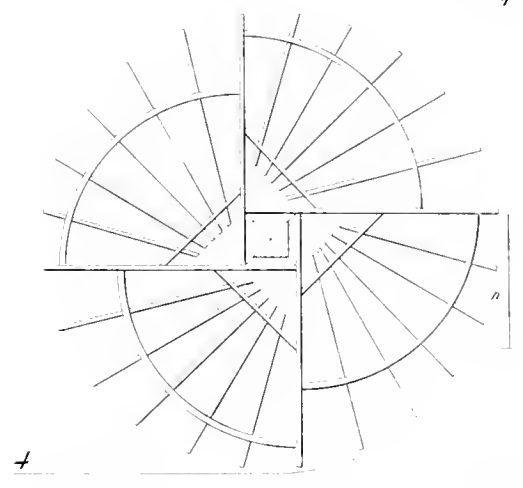
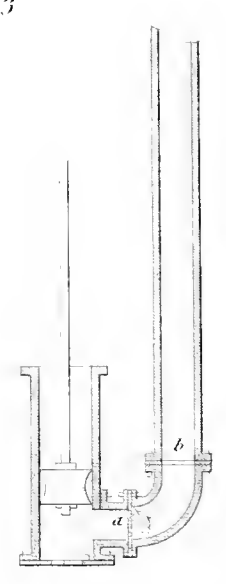
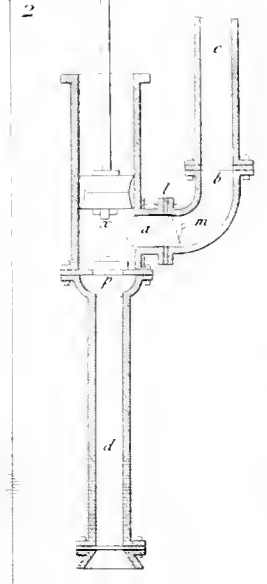
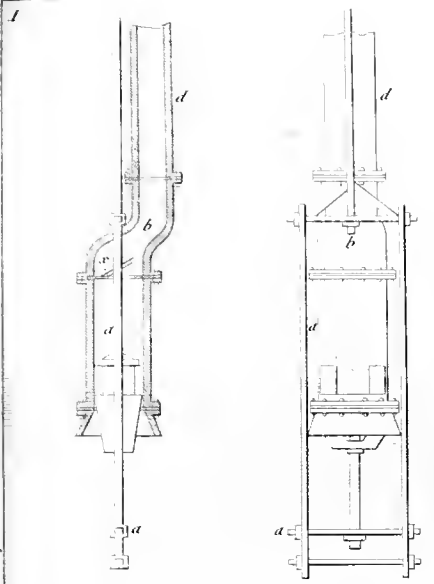




Fig. 2.

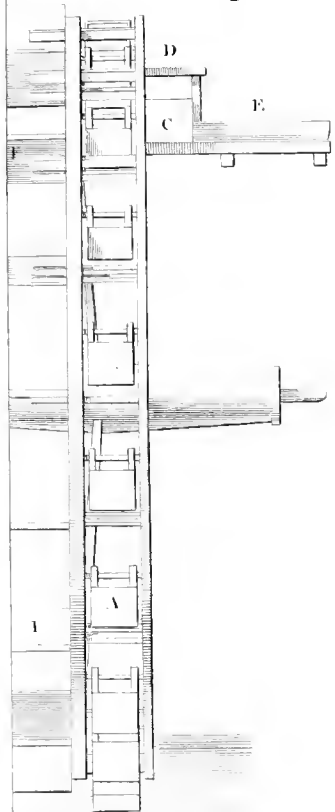
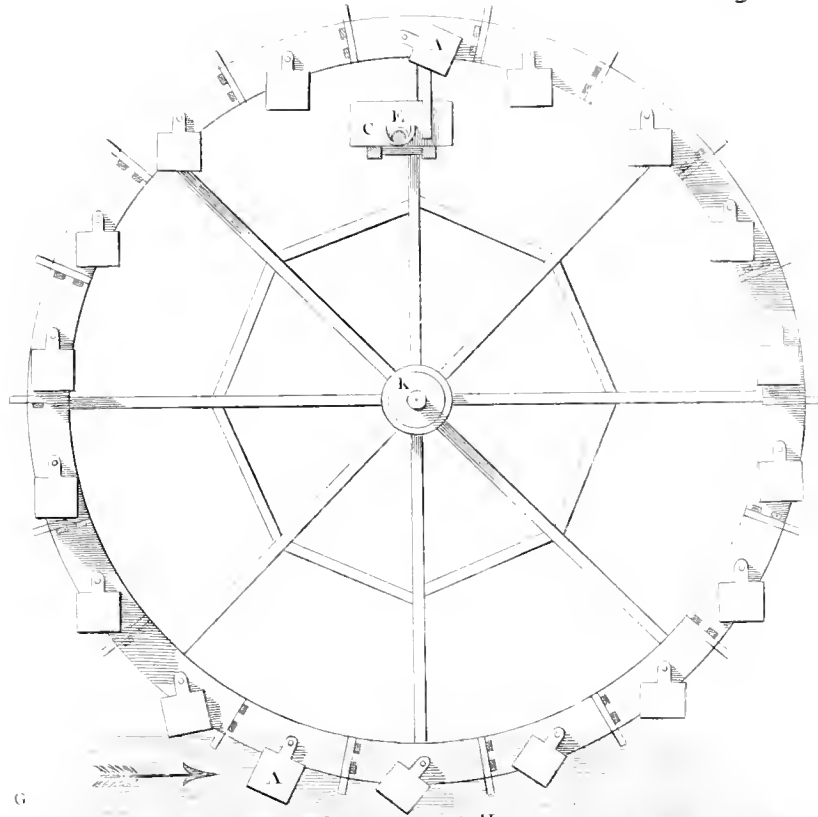


Fig. 1.



1/2 to 1/3

1

2

3

4

5

6

7

8

9

10

11

12

13

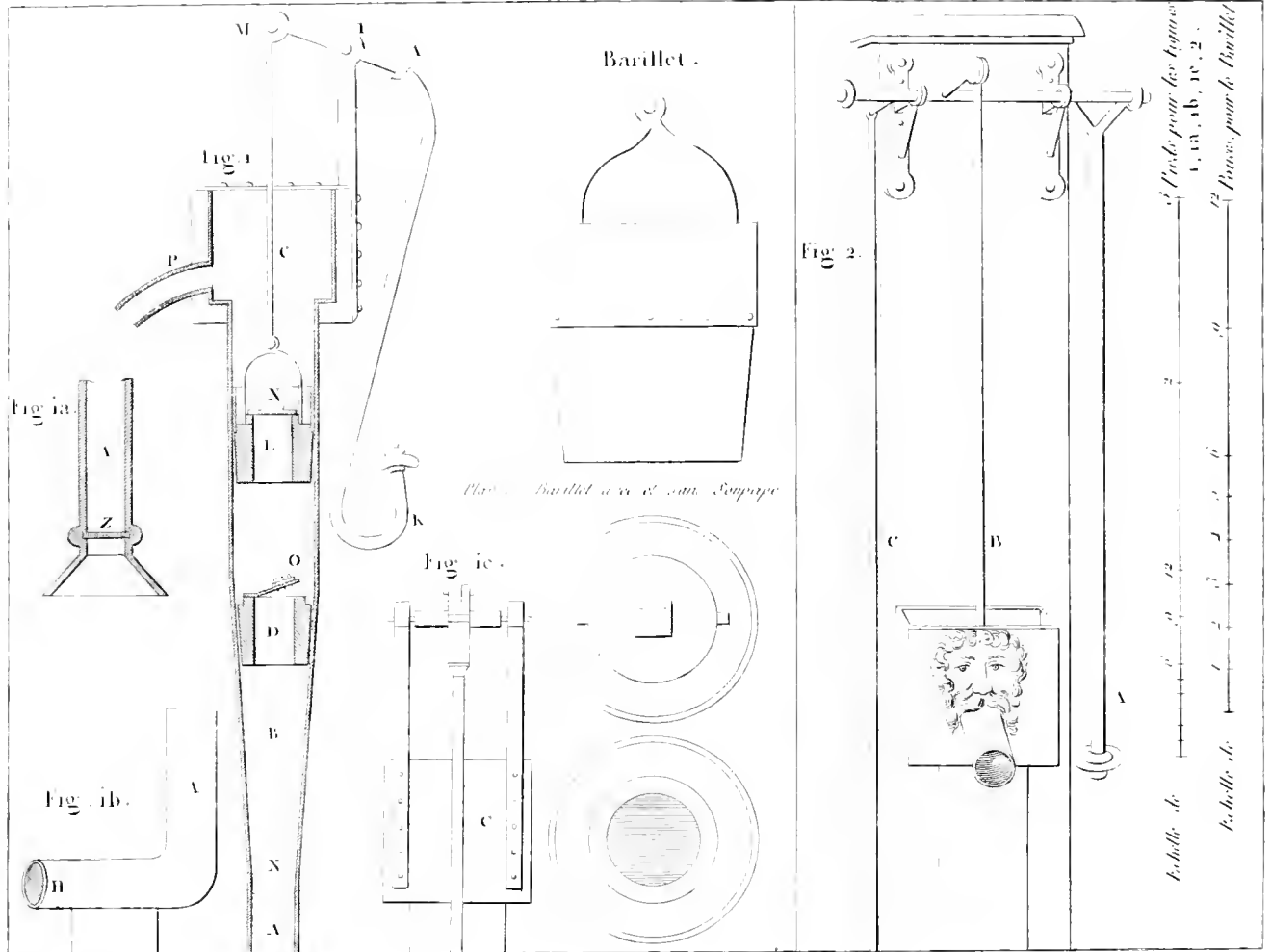
14

15

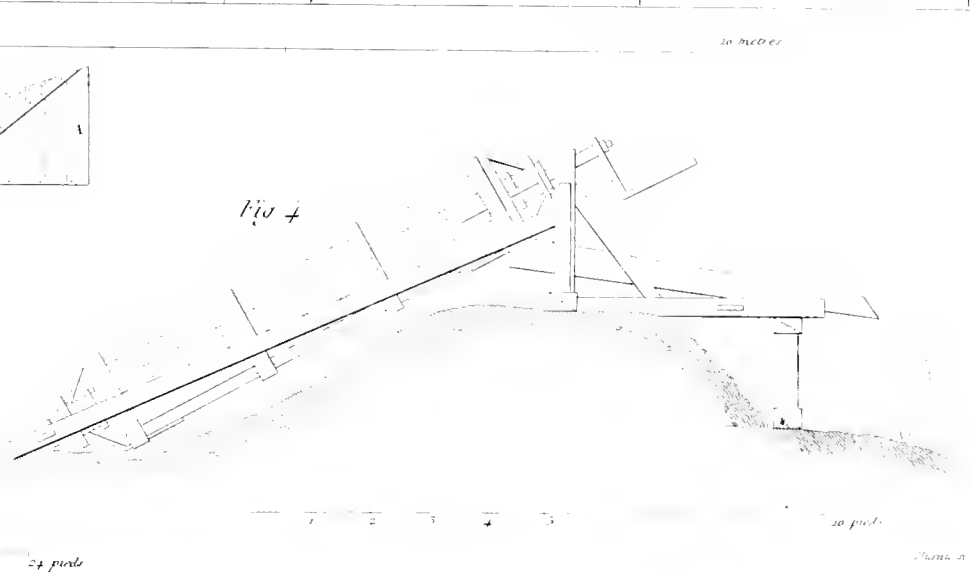
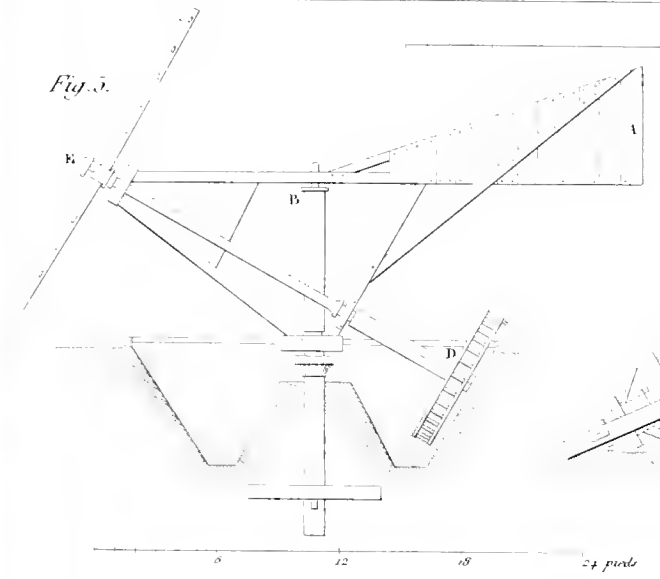
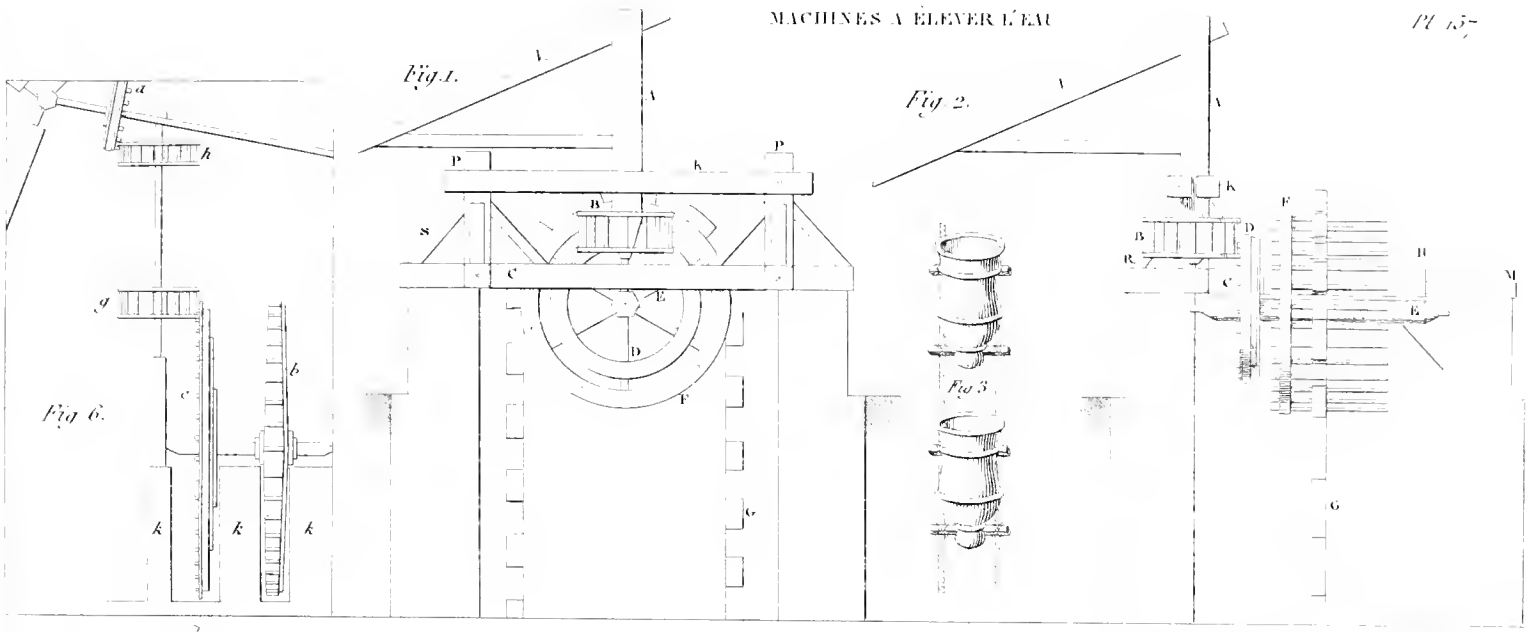
16

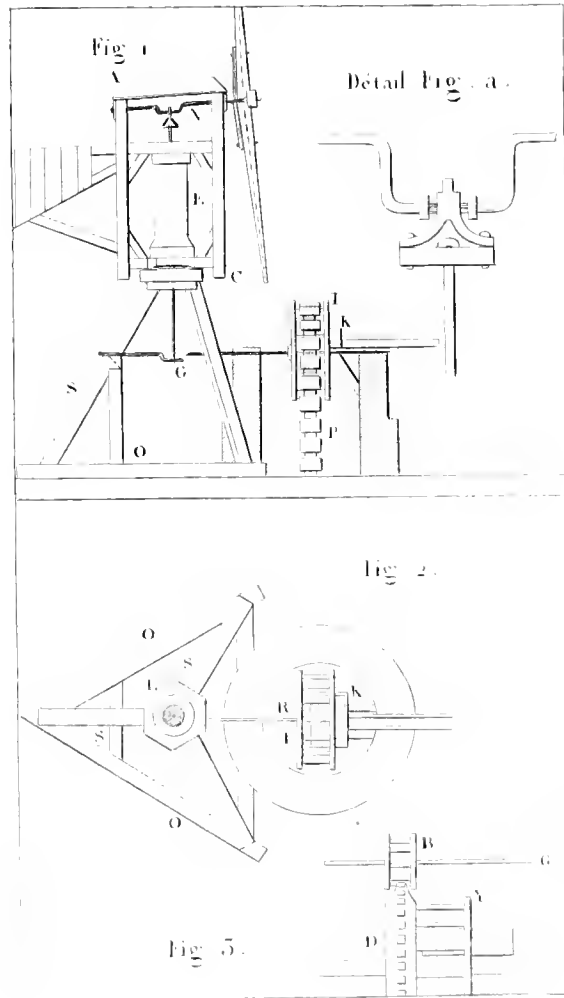
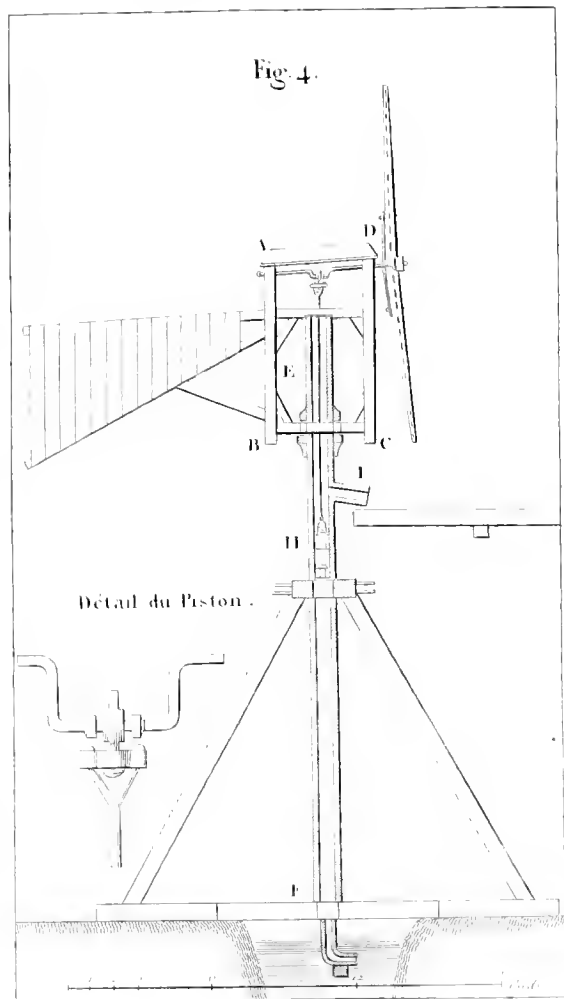
17



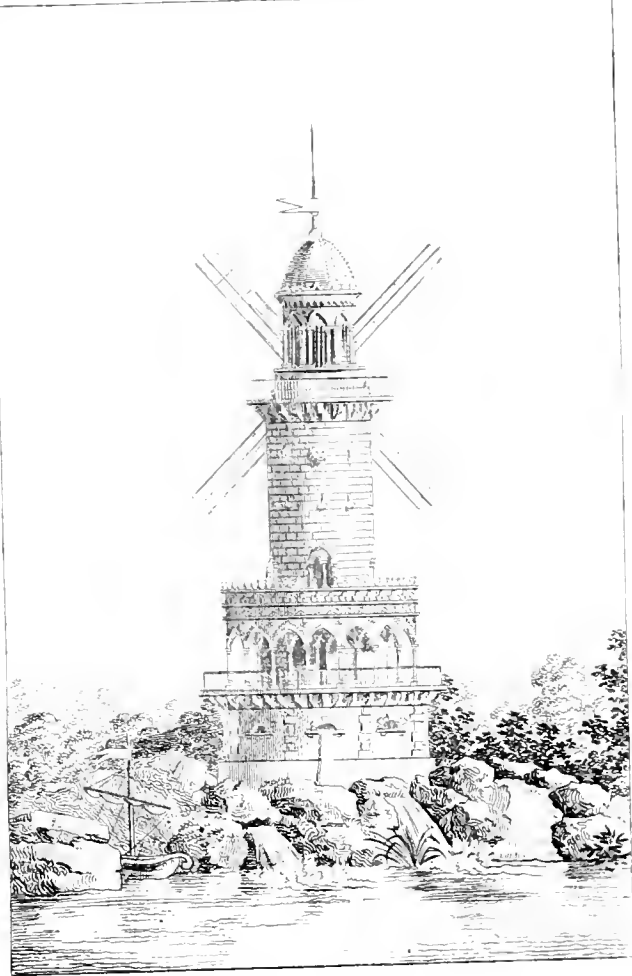
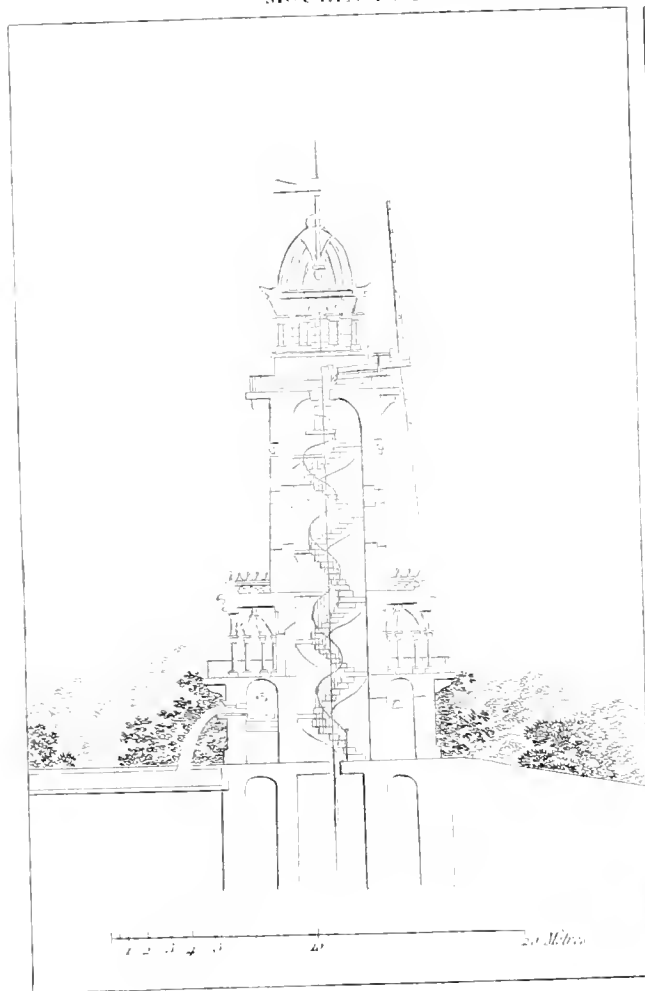


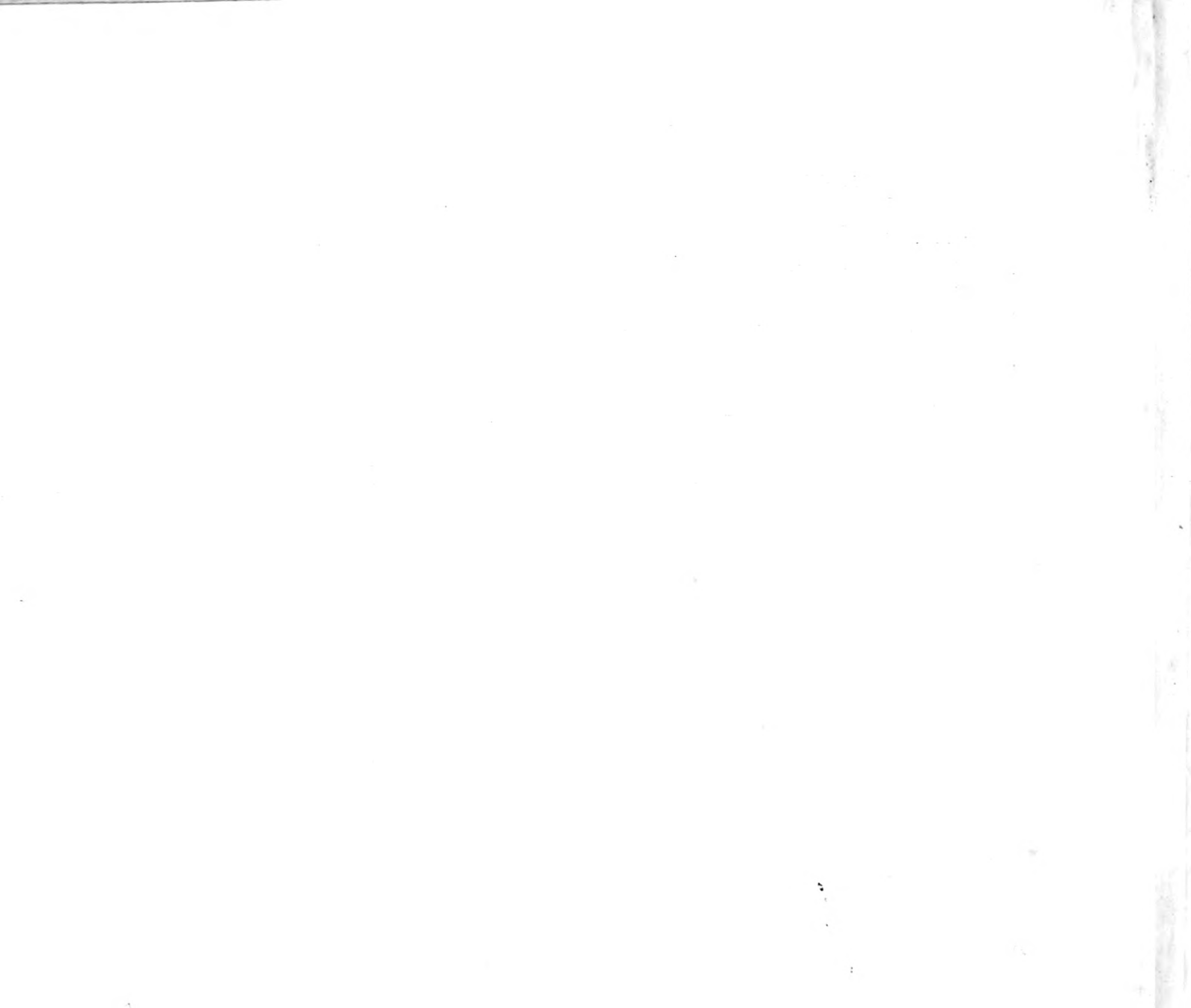




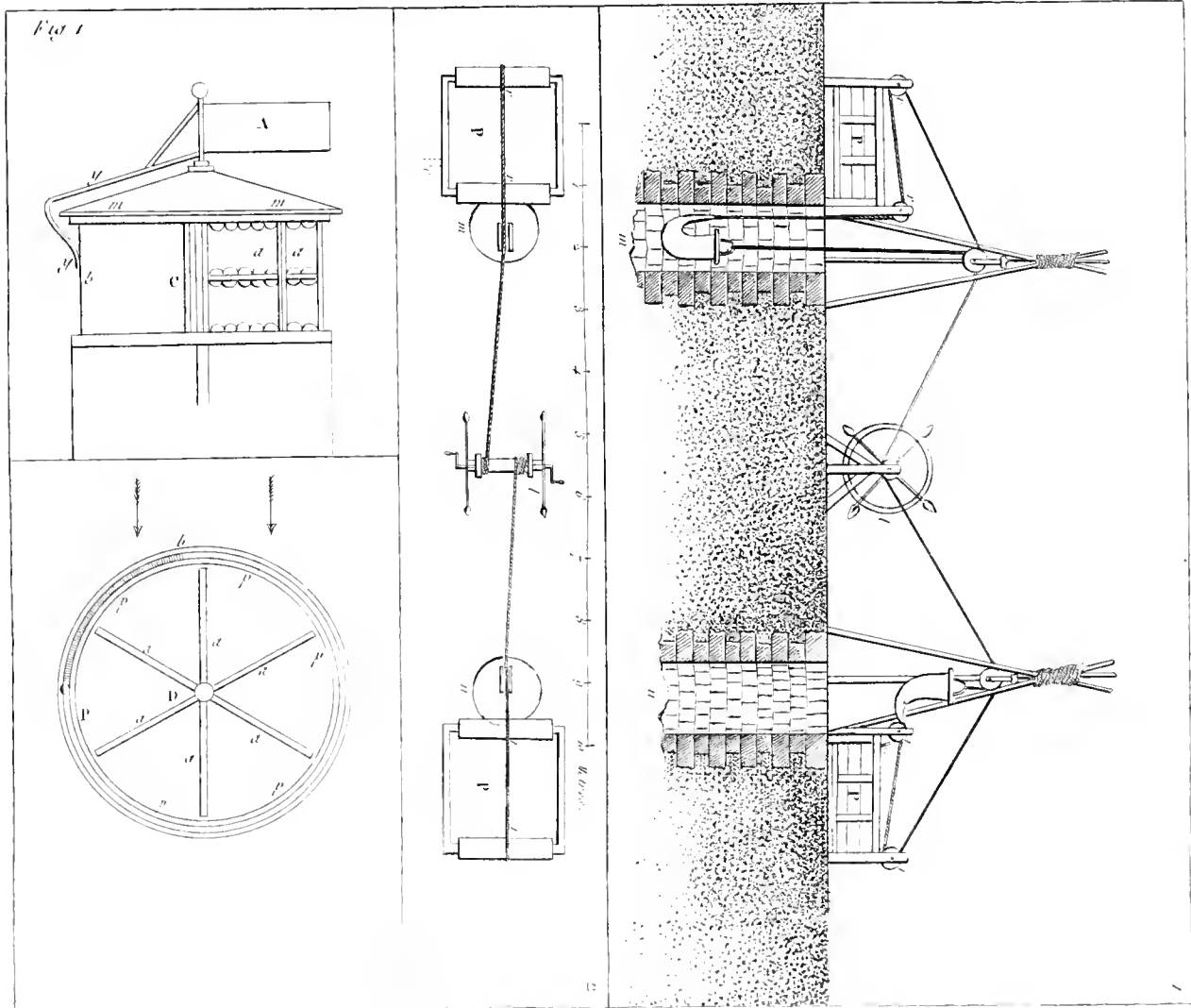


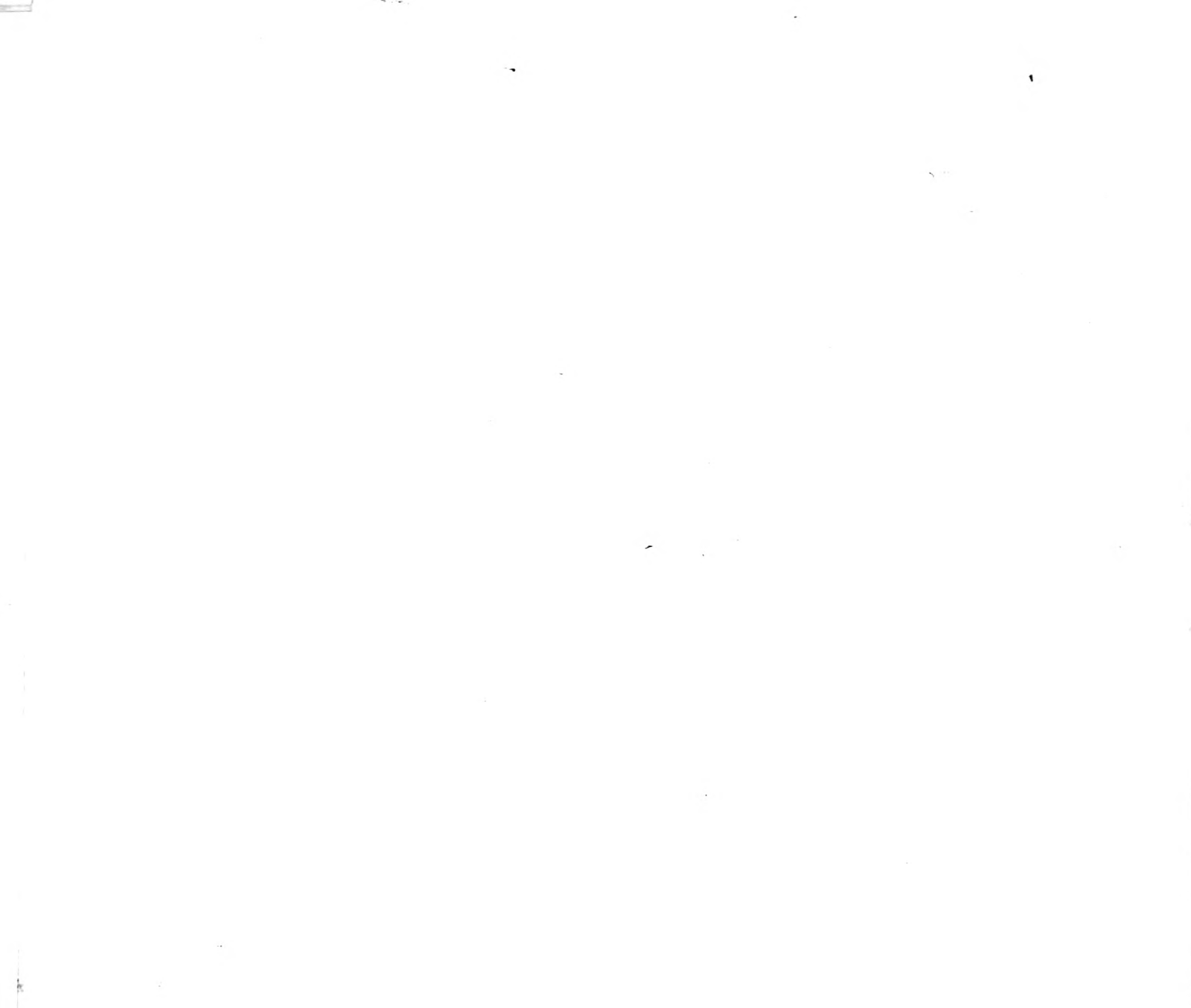






MOULIN A GIROUETTE.





Special
84-B
26371
v.2

GETTY CENTER

