

S. G. B 10.

TRANSACTIONS



CAMBRIDGE

PHILOSOPHICAL SOCIETY.

ESTABLISHED NOVEMBER 15, 1819.

VOLUME THE TENTH.

CAMBRIDGE:

Printed at the University Press;

AND SOLD BY

DEIGHTON, BELL AND CO. AND MACMILLAN AND CO. CAMBRIDGE;
BELL AND DALDY, LONDON.

M.DCCC.LXIV.

Cambridge:

PRINTED BY C. J. CLAY, M.A.
AT THE UNIVERSITY PRESS.



CONTENTS.

PART I.

		PAGE
No. I.	<i>On a Direct Method of estimating Velocities, Accelerations, and all similar Quantities with respect to Axes moveable in any manner in Space, with Applications.</i> By R. B. HAYWARD, M.A., Fellow of St John's College, Reader in Natural Philosophy in the University of Durham.....	1
II.	<i>On the question, What is the Solution of a Differential Equation? A Supplement to the third section of a paper, On some points of the Integral Calculus, printed in Vol. IX. Part II.</i> By AUGUSTUS DE MORGAN, of Trinity College, Vice-President of the Royal Astronomical Society, and Professor of Mathematics in University College, London	21
III.	<i>On Faraday's Lines of Force.</i> By J. CLERK MAXWELL, B.A., Fellow of Trinity College, Cambridge	27
IV.	<i>The Structure of the Athenian Trireme; considered with reference to certain difficulties of interpretation.</i> By J. W. DONALDSON, D.D., late Fellow of Trinity College, Cambridge	84
V.	<i>Of the Platonic Theory of Ideas.</i> By W. WHEWELL, D.D., Master of Trinity College, Cambridge	94
VI.	<i>On the Discontinuity of Arbitrary Constants which appear in Divergent Developments.</i> By G. G. STOKES, M.A., D.C.L., Sec. R.S., Fellow of Pembroke College, and Lucasian Professor of Mathematics in the University of Cambridge	105
VII.	<i>On the Beats of Imperfect Consonances.</i> By AUGUSTUS DE MORGAN, F.R.A.S., of Trinity College, Professor of Mathematics in University College, London	129
VIII.	<i>On the Genuineness of the Sophista of Plato, and on some of its philosophical bearings.</i> By W. H. THOMPSON, M.A., Fellow of Trinity College, and Regius Professor of Greek	146
IX.	<i>On the Substitution of Methods founded on Ordinary Geometry for Methods based on the General Doctrine of Proportions, in the Treatment of some Geometrical Problems.</i> By G. B. AIRY, Esq., Astronomer Royal.	166
X.	<i>On the Syllogism, No. III., and on Logic in general.</i> By AUGUSTUS DE MORGAN, F.R.A.S., of Trinity College, Professor of Mathematics in University College, London	173
XI.	<i>On the Statue of Solon mentioned by Æschines and Demosthenes.</i> By J. W. DONALDSON, D.D., Vice-President of the Society	231
XII.	<i>Instances of remarkable Abnormalities in the Voluntary Muscles.</i> By G. E. PAGET, M.D., F.R.C.P., late Fellow of Gonville and Caius College	240
XIII.	<i>On Organic Polarity.</i> By H. F. BAXTER, Esq., M.R.C.S.L.	248
XIV.	<i>A Proof of the Existence of a Root in every Algebraic Equation: with an examination and extension of Cauchy's Theorem on Imaginary Roots, and Remarks on the Proofs of the existence of Roots given by Argand and by Mourey.</i> By AUGUSTUS DE MORGAN, F.R.A.S., of Trinity College, Professor of Mathematics in University College, London.....	261

CONTENTS.

PART II.

		PAGE
No. I.	<i>On a Chart and Diagram for facilitating Great-Circle Sailing. By HUGH GODFRAY, M.A., St John's College</i>	271
II.	<i>Suggestion of a Proof of the Theorem that every Algebraic Equation has a Root. By G. B. AIRY, Esq., Astronomer Royal.....</i>	283
III.	<i>On the General Principles of which the Composition or Aggregation of Forces is a Consequence. By AUGUSTUS DE MORGAN, F.R.A.S., of Trinity College, Professor of Mathematics in University College, London</i>	290
IV.	<i>On Plato's Cosmical System as exhibited in the Tenth Book of "The Republic." By J. W. DONALDSON, D.D., Trinity College; Vice-President of the Society</i>	305
V.	<i>On the Origin and Proper Use of the word ARGUMENT. By J. W. DONALDSON, D.D., late Fellow of Trinity College, Cambridge</i>	317
VI.	<i>Supplement to a Proof of the Theorem that every Algebraic Equation has a Root. By G. B. AIRY, Esq., Astronomer Royal</i>	327
VII.	<i>On the Syllogism, No. IV., and on the Logic of Relations. By AUGUSTUS DE MORGAN, F.R.A.S., of Trinity College, Professor of Mathematics in University College, London</i>	331
VIII.	<i>On the Motion of Beams and thin Elastic Rods. By J. H. RÖHRS, M.A., Fellow of the Cambridge Philosophical Society.....</i>	359
IX.	<i>On a Metrical Latin Inscription copied by Mr BLAKESLEY at Cirta and published in his "Four Months in Algeria." By H. A. J. MUNRO, M.A., Fellow of Trinity College</i>	374
X.	<i>On the Theory of Errors of Observation. By AUGUSTUS DE MORGAN, F.R.A.S., of Trinity College, Professor of Mathematics in University College, London</i>	409
XI.	<i>On the Syllogism, No. V., and on various points of the Onymatic System. By AUGUSTUS DE MORGAN, F.R.A.S., of Trinity College, Professor of Mathematics in University College, London.....</i>	428

ADVERTISEMENT.

THE Society as a body is not to be considered responsible for any facts and opinions advanced in the several Papers, which must rest entirely on the credit of their respective Authors.

THE SOCIETY takes this opportunity of expressing its grateful acknowledgments to the SYNDICS of the University Press, for their liberality in taking upon themselves the expense of printing this Volume of the Transactions.

TRANSACTIONS



CAMBRIDGE

PHILOSOPHICAL SOCIETY.

VOLUME X. PART I.

CAMBRIDGE:

PRINTED BY C. J. CLAY, M. A. AT THE UNIVERSITY PRESS;

AND SOLD BY

DEIGHTON, BELL AND CO. AND MACMILLAN AND CO. CAMBRIDGE;

BELL AND DALDY, LONDON.

M. DCCC. LVIII.



I. *On a Direct Method of estimating Velocities, Accelerations, and all similar Quantities with respect to Axes moveable in any manner in Space, with Applications.* By R. B. HAYWARD, M.A. Fellow of St John's College, Reader in Natural Philosophy in the University of Durham.

[Read Feb. 25, 1856.]

"...gardons-nous de croire qu'une science soit faite quand on l'a réduite à des formules analytiques. Rien ne nous dispense d'étudier les choses en elles-mêmes, et de nous bien rendre compte des idées qui font l'objet de nos spéculations." POINSOT.

"...c'est une remarque que nous pouvons faire dans toutes nos recherches mathématiques; ces quantités auxiliaires, ces calculs longs et difficiles où l'on se trouve entraîné, y sont presque toujours la preuve que notre esprit n'a point, dès le commencement, considéré les choses en elles-mêmes et d'une vue assez directe, puisqu'il nous faut tant d'artifices et de détours pour y arriver; tandis que tout s'abrège et se simplifie sitôt qu'on se place au vrai point de vue." *Ibid.*

THE general principles, which I have endeavoured to keep in view in the investigations of this paper, are those contained in the above quotations from Poinsot. My object is not so much to obtain new results, as to regard old ones from a point of view which renders all our equations directly significant, and to develop a corresponding method, by which these equations result directly from one central principle instead of being (as is commonly the case) deduced by long processes of transformation and elimination from certain fundamental equations, in which that principle has been embodied.

The frequent occurrence of exactly corresponding equations, (though this correspondence is sometimes disguised under a different mode of expression) in many investigations of Kinematics and Dynamics suggests the inquiry whether they do not result from some common principle, from which they may be deduced once for all. An investigation based on this idea forms the first part of this paper, in which it will be shewn how the variations of any magnitude, which is capable of representation by a line of definite length in a definite direction and is subject to the *parallelogrammic* law of combination, may be *simply* and *directly* estimated relatively to any axes whatever. The second part is devoted to the general problem of the dynamics of a material system, treated in that form which the previous Calculus suggests, together with a development of the solution in the case of a body of invariable form.

Since whatever novelty of view is contained in this paper consists rather in the relation of the details to the general method than in the details themselves, much that is familiar to every student of Dynamics must be repeated in its proper place, but it is hoped that such repetition will in general be compensated by a new or fuller significance being obtained. As regards the problem of rotation, M. Poinsot's solution in the "Théorie de la Rotation" is so

complete and so entirely satisfies the conditions expressed in our quotations above from that work, as to leave nothing to be desired. But it does not appear to me that his method, which depends essentially on the summation of the centrifugal forces, is so widely applicable beyond the limits of this particular problem as that by which the same results are obtained in this paper: but be this as it may, any new point of view, if a true one ("vrai point de vue") has its special advantages, and on this ground may claim some attention.

SECTION I.

The Method, with some kinematical Applications.

1. As we shall here be concerned only with the *directions* of lines in space, and not with their absolute positions, it will be convenient to suppose them all to pass through a common origin O , and to define the inclination of two lines as OP, OQ by the arc PQ of the great circle, in which the plane POQ meets a sphere whose centre is O and radius constant. We shall also suppose any linear velocity, acceleration or force, represented by a length along OP , to tend *from O towards P* , and any angular velocity or the like, represented in like manner, to tend in such a direction about OP that, if OP were directed to the north pole, the direction of rotation would coincide with that of the diurnal motion of the heavens.

2. Let u denote any magnitude, which can be completely represented by a certain length along the line OU , and which can be combined with a similar magnitude v along OV by means of a parallelogram, like the parallelogram of forces or velocities. Then of course u may be resolved in different directions by the same principles, and thus if we adopt *rectangular* resolution, the resolved part of u along OP will be $u \cos UP$, which may be denoted by u_p . We proceed to inquire how u_p varies by a change in the position of OP .

3. Suppose OP to be a line moving in any manner about O , and that it shifts from OP to a consecutive position OP' in the time dt ; and conceive that this motion arises from an angular velocity Ω about an instantaneous axis OI . Resolve Ω into its components $\Omega \cos IU$ about OU and $\Omega \sin IU$ about a line in the plane IOU , perpendicular to OU : and farther resolve this latter component in the plane perpendicular to OU into the components $\Omega \sin IU \cdot \cos IUP$ in the plane POU and $\Omega \sin IU \cdot \sin IUP$ perpendicular to the same plane.

Then the component in OU and that perpendicular to it in the plane POU produce displacements of P perpendicular to the arc UP , and consequently do not ultimately alter the length of the arc UP , so that u_p remains ultimately unchanged so far as the motion of OP is due to these components: but the component perpendicular to the plane POU increases UP by the arc $\Omega \sin IU \cdot \sin IUP \cdot dt$, and therefore the increment of u_p from this component (being equal to $-u \cdot \sin UP \cdot d \cdot UP$) is

$$-u\Omega \sin UP \cdot \sin IU \cdot \sin IUP \cdot dt.$$

But the other increments being zero, this is the *total* increment of u_p , wherefore we have

$$\frac{d \cdot u_p}{dt} = -u\Omega \sin IU \cdot \sin UP \cdot \sin IUP \dots (A).$$

It is well to observe that $\frac{d \cdot u_p}{dt}$ vanishes, when the three axes OI , OU , OP lie in the same plane, and in particular when two of them coincide, as is evident from the above equations, or from considerations similar to those by which it was obtained.

4. In the above investigation we have supposed u to be constant both in direction and intensity; let us now suppose u to vary in both respects with the time (t). The change in u in the time dt may be conceived to arise from its composition with the quantity $f dt$ in the line OF , and f may properly be called the acceleration of u at the time t . Now $f dt$ may be resolved in the plane UOF into $f \cdot dt \cos FU$ along OU and $f \cdot dt \sin FU$ perpendicular to OU , and the components of $u + du$ will therefore be $u + f \cdot dt \cos FU$ along OU and $f \cdot dt \sin FU$ perpendicular to OU ; whence, if $d\phi$ denote the angle through which OU shifts in the time dt towards OF , it will readily be seen that ultimately

$$\frac{du}{dt} = f \cos FU, \quad u \frac{d\phi}{dt} = f \sin FU \dots (B).$$

If then the acceleration f be known both as to direction and intensity at every instant, the motion of OU and the variation in the intensity of u may be determined by these last equations. In fact, the point U on the sphere of reference continually follows the point F with the velocity $\frac{d\phi}{dt}$, so that the problem of determining U 's path is the same as the old problem of the path described by a dog always running towards his master who is himself in motion, the only difference being that the path is here on a sphere instead of a plane.

5. Next for the variation of u_p , when u varies with the time. It is plain that u_p varies from two causes; first, by reason of the acceleration f , and secondly, by reason of the motion of OP due to the angular velocity Ω about OI , and that the total variation will be the sum of these two partial variations. Now the latter has been calculated above, and the former is obviously the resolved part of $f dt$ along OP or $f \cdot dt \cos FP$, therefore we obtain the equation*

$$\frac{d \cdot u_p}{dt} = f \cos FP - u \Omega \sin IU \cdot \sin UP \cdot \sin IUP \dots (C).$$

This equation of course contains the previous equations (B): thus, if OP and OU coincide always, UP is always zero and the second side of (C) reduces to its first term: and again if OP be always in the plane FOU and perpendicular to OU , u_p is always zero, $\Omega = \frac{d\phi}{dt}$, IU and UP are quadrants, IUP a right angle, and FP the complement of FU , and therefore, as above,

$$0 = f \sin FU - u \frac{d\phi}{dt}.$$

6. We may farther illustrate the application of equation (C) by supposing OP to coincide with certain other lines specially connected with OU and OF .

* It should be remarked here that the angle IUP must be considered positive or negative, according as the positive rotation Ω about OI causes the motion of P , resolved in the arc UP , to be from or towards U .

Let U, U', U'' and F, F', F'' be three consecutive positions of U and F respectively, and K, K' those poles of $FF', F'F''$ respectively, (considered as arcs of great circles) about which positive rotation brings F to F' , and F' to F'' . We know that U' lies on the arc UF between U and F , and U'' on the arc $U'F'$ between U' and F' . Also it is plain that F' is the pole of KK' , and therefore that KK' measures the *angle of contingence* between the consecutive elements $FF', F'F''$: in fact, the loci of K and F are so connected that the elementary arcs of the one are equal to the angles of contingence of the other, and vice versa.

Suppose the locus of F to be defined by elements, corresponding to what Dr Whewell has named in plane curves *intrinsic* elements, that is, by elements α, ϵ such that the elementary arc $FF' = d\alpha$, and the angle of contingence between FF' and $F'F'' = d\epsilon$: and suppose the locus of U defined in like manner, so that $UU' = d\phi$, and the angle of contingence $FU'U'' = d\eta$. Also let $UF = \mu$, and angle $UFF' = \nu$.

Now let OP coincide always with OF . Then will $u_p = u \cos \mu$, and I being taken to coincide with k , $\Omega = \frac{d\alpha}{dt}$, and therefore equation (3) becomes

$$\frac{d}{dt} (u \cos \mu) = f - u \frac{d\alpha}{dt} \cdot \sin \mu \cdot \sin KU \cdot \sin KUF.$$

But $\sin kU \cdot \sin kUF = \sin kFU = \sin \left(\frac{\pi}{2} - \nu \right) = \cos \nu$,

$$\text{and } \frac{du}{dt} = f \cos \mu;$$

therefore we obtain after reduction

$$\frac{d\mu}{dt} - \frac{d\alpha}{dt} \cos \nu + \frac{f}{u} \sin \mu = 0 \dots (1).$$

Again let OP coincide always with OK , then

$$u_p = u \cos UK = u \sin \mu \cdot \cos UFK = u \sin \mu \cdot \sin \nu,$$

and I may be taken to coincide with F'' or ultimately with F , so that (3) becomes,

$\left(\Omega \text{ being } = \frac{d\epsilon}{dt} \right),$

$$\begin{aligned} \frac{d}{dt} (u \sin \mu \cdot \sin \nu) &= -u \frac{d\epsilon}{dt} \cdot \sin FU \cdot \sin UK \cdot \sin FUK \\ &= -u \frac{d\epsilon}{dt} \sin \mu \cdot \cos \nu, \end{aligned}$$

or after reduction

$$\frac{d\mu}{dt} + \left(\frac{d\nu}{dt} + \frac{d\epsilon}{dt} \right) \cdot \frac{\tan u}{\tan \nu} + \frac{f}{u} \sin \mu = 0 \dots (2).$$

The equations (1) and (2) together with the two equations (B) serve to determine (after eliminating μ and ν) $\frac{du}{dt}$ and $\frac{d\phi}{dt}$, when $f, \frac{d\alpha}{dt}, \frac{d\epsilon}{dt}$ are given, that is, when the intensity and

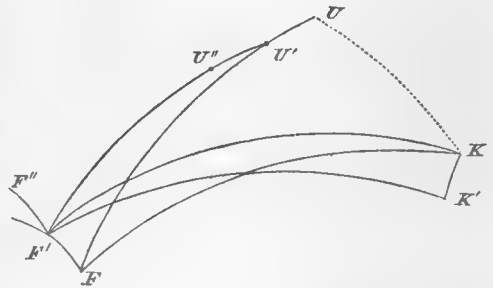

variation in direction of the acceleration of u are given for every instant. And we have also from the triangle $FU'F'$ ultimately

$$\frac{d\eta}{dt} \cdot \sin \mu = \frac{da}{dt} \cdot \sin \nu,$$

to determine $\frac{d\eta}{dt}$: and therefore we have equations to determine the intensity and variation in direction of u itself. Hence we have obtained a solution of the problem, "Given the path of F and the variable intensity of f , to determine the path of U and the intensity of u ," the whole being referred to intrinsic elements.

7. It will be useful to obtain results analogous to equation (C) for three rectangular axes in a somewhat different form. Of course these might be obtained from that equation itself, but it will be better to investigate them independently by the same kind of reasoning.

Let u_x, u_y, u_z denote the resolved parts of u along the moveable rectangular axes Ox, Oy, Oz , and let $\Omega_x, \Omega_y, \Omega_z$ and f_x, f_y, f_z denote in like manner the resolved parts of Ω and f . Now by reason of the acceleration f , u_x receives in the time dt the increment $f_x dt$: also Ox changes its position by reason of the rotations Ω_y, Ω_z , the first of which shifts it in the plane of zx through the angle $\Omega_y dt$ from Oz , and the latter in the plane of xy through the angle $\Omega_z dt$ towards Oy ; and from the first of these causes u_x receives the increment

$$u_x \cos \left(\frac{\pi}{2} + \Omega_y dt \right) + u_x \cos (\Omega_y dt) - u_x,$$

or $-u_x \Omega_y dt$ ultimately, while from the second it receives the increment

$$u_y \cos \left(\frac{\pi}{2} - \Omega_z dt \right) + u_x \cos (\Omega_z dt) - u_x,$$

or $u_y \Omega_z dt$ ultimately. Hence the total increment of u_x , being the sum of these partial increments, we obtain the equation

$$\frac{du_x}{dt} = f_x + u_y \Omega_z - u_x \Omega_y,$$

Similarly for u_y, u_z we should obtain

$$\frac{du_y}{dt} = f_y + u_x \Omega_z - u_y \Omega_x,$$

$$\frac{du_z}{dt} = f_z + u_x \Omega_y - u_y \Omega_x,$$

}(E).

8. To illustrate the applicability of these last obtained equations, we will select a few particular kinematical problems.

a. Relative velocities of a point in motion with respect to revolving axes.

From the nature of the quantity u , it will be seen that it may be taken to denote the radius vector OP of a point P , and u_x, u_y, u_z may then be replaced by the co-ordinates, x, y, z : also f , denoting the acceleration of u , will in this case denote the absolute velocity of P , and f_x, f_y, f_z the absolute velocities resolved in the directions of the axes, which we will denote by v_x, v_y, v_z . Then by the equations above we have three equations, of which the type is

$$\frac{dx}{dt} = v_x + y\Omega_z - z\Omega_y,$$

and which determine the relative velocities $\frac{dx}{dt}$, $\frac{dy}{dt}$, $\frac{dz}{dt}$ of the point with respect to the co-ordinate axes.

If the point be fixed relatively to the axes, and x_0, y_0, z_0 be its co-ordinates, the above equation becomes

$$v_x = \Omega_y \cdot z_0 - \Omega_z \cdot y_0,$$

one of a set of well known equations, determining the linear velocity of a point in a body revolving with given angular velocities.

If the point lie in the axis of x , so that y, z both vanish,

$$\frac{dx}{dt} = v_x, \quad 0 = v_y - x\Omega_z, \quad 0 = v_z + x\Omega_y.$$

In these, if x, y, z are in the directions of the radius vector, a perpendicular to it in the vertical plane, and a perpendicular to this plane respectively, and if r, θ, ϕ denote radius vector, altitude and azimuth, then

$$x = r, \quad \Omega_y = -\frac{d\phi}{dt} \cos \theta, \quad \Omega_z = \frac{d\theta}{dt},$$

whence

$$v_x = \frac{dr}{dt}, \quad v_y = r \frac{d\theta}{dt}, \quad v_z = r \cos \theta \frac{d\phi}{dt},$$

the common expressions for the components, relatively to polar co-ordinates, of the velocity of a point.

b. Accelerations, radial, transversal in the vertical plane, and perpendicular to that plane.

In our general formulæ u will now denote a velocity, and f an acceleration strictly so called. And in this case

$$u_x = \frac{dr}{dt}, \quad u_y = r \frac{d\theta}{dt}, \quad u_z = r \cos \theta \frac{d\phi}{dt},$$

$$\Omega_x = -\frac{d\phi}{dt} \sin \theta, \quad \Omega_y = -\frac{d\phi}{dt} \cos \theta, \quad \Omega_z = \frac{d\theta}{dt},$$

wherefore, by equations (E)

$$\text{radial acceleration} = f_x = \frac{d^2r}{dt^2} - \left(r \cdot \frac{d\theta}{dt} \right)^2 + r \cos^2 \theta \left(\frac{d\phi}{dt} \right)^2,$$

transversal acceleration in the vertical plane = f_y

$$= \frac{d}{dt} \left(r \frac{d\theta}{dt} \right) - \left(-r \sin \theta \cdot \cos \theta \frac{d\phi}{dt} \right)^2 - \frac{dr}{dt} \cdot \frac{d\theta}{dt}$$

$$= \frac{1}{r} \frac{d}{dt} \left(r^2 \frac{d\theta}{dt} \right) + r \sin \theta \cdot \cos \theta \frac{d\phi}{dt} \left(\frac{d\phi}{dt} \right)^2,$$

$$\text{azimuthal acceleration} = f_z = \frac{d}{dt} \left(r \cos \theta \frac{d\phi}{dt} \right) - \left(-\frac{dr}{dt} \cdot \frac{d\phi}{dt} \cos \theta + r \sin \theta \frac{d\theta}{dt} \cdot \frac{d\phi}{dt} \right)$$

$$= \frac{1}{r \cos \theta} \cdot \frac{d}{dt} \left(r^2 \cos^2 \theta \cdot \frac{d\phi}{dt} \right).$$

c. Let the axes of x, y, z be always parallel to the tangent, principal normal and normal to the osculating plane of any curve. Then

$$\begin{aligned} u_x &= \frac{ds}{dt}, & u_y &= 0, & u_z &= 0, \\ \Omega_x &= \frac{d\tau}{dt}, & \Omega_y &= 0, & \Omega_z &= \frac{d\epsilon}{dt}, \end{aligned}$$

where $d\epsilon, d\tau$ denote respectively the angle between consecutive tangents, and that between consecutive osculating planes.

Hence

$$\text{tangential acceleration} = f_x = \frac{d^2s}{dt^2},$$

$$\text{acceleration in principal normal} = f_y = \frac{ds}{dt} \cdot \frac{d\epsilon}{dt} = \left(\frac{ds}{dt} \right)^2 \cdot \frac{d\epsilon}{ds} = \frac{1}{\rho} \left(\frac{ds}{dt} \right)^2,$$

$$\text{acceleration in normal to osculating plane} = f_z = 0.$$

SECTION II.

Dynamical Applications.

9. I propose here to consider the problem of the motion of *any* material system, so far as it depends on *external forces only*, and to develop the solution in that case in which the *entire* motion is determined by these forces, namely, in the case of an *invariable* system.

10. This problem naturally resolves itself into two: for, since every system of forces is reducible to a single force and a single couple, we have to investigate the effects of that force, and the effects of that couple. Now we know that the resultant force determines the motion of the centre of gravity of the system, be the constitution of the system what it may. In like manner the resultant couple determines something relatively to the motion of the system *about* its centre of gravity, which in the case of an invariable system defines its motion of rotation about that point, but which in other cases is not usually recognised as a definite objective magnitude, and has therefore no received name. This defect will be remedied by adopting *momentum* as the intermediate term between *force* and *velocity*, and by regarding as distinct steps the passage from *force* to *momentum* and that from *momentum* to *velocity*. In accordance with this idea we proceed to shew that as in our first problem we shall be concerned with the magnitudes, *force*, *linear momentum* or *momentum of translation*, and *linear velocity* or *velocity of translation*, so in the other we shall be concerned with the corresponding magnitudes, *couple*, *angular momentum* or *momentum of rotation*, and *angular velocity* or *velocity of rotation*; and that, as all these magnitudes possess the properties characteristic of the magnitude u in the previous section, the Calculus there developed is applicable to them.

11. Consider a material system at any instant of its motion. Each particle is moving with a definite momentum in a definite direction, which may be resolved into components in given directions in the same manner as a velocity or a force. Let this momentum be resolved in the direction of a given axis OP , and its moment about that axis taken, the resolved part may be called the *linear momentum*, and the moment the *angular momentum*, of the particle relatively to the axis OP . Let the same be done for every particle of the system, and the sums of their linear and angular momenta taken, these sums may then be called respectively the *linear and angular momenta of the system* relatively to the axis OP .

12. Let the linear momenta relatively to the three axes Ox, Oy, Oz be denoted by u_x, u_y, u_z , and the corresponding angular momenta by h_x, h_y, h_z respectively; then it may easily be shewn that the linear momentum relatively to the axis, whose direction-cosines are l, m, n , is

$$lu_x + mu_y + nu_z,$$

and that the angular momentum relatively to the same axis is

$$lh_x + mh_y + nh_z.$$

The first expression will be a maximum, and equal to $\{u_x^2 + u_y^2 + u_z^2\}^{\frac{1}{2}}$, when

$$l : m : n :: u_x : u_y : u_z;$$

and if this be denoted by u , it is plain that the linear momentum along any line inclined to the direction of u at an angle θ will be $u \cos \theta$. Hence we may regard the whole linear momentum of the system as equivalent to the single linear momentum u determinate in intensity and direction.

In like manner we may conclude that the whole angular momentum is reducible to a single angular momentum h determinate in intensity and direction.

13. Thus, just as a system of forces is reducible to a single force and a single couple, the momenta of the several particles of a system are reducible to a single linear and a single angular momentum, which we shall speak of as *the* linear and angular momenta of the system. It is to be observed that the linear momentum u is independent of the origin O both as regards direction and intensity, but the angular momentum h is in both respects dependent on the position of O . Also it may be proved, as in the case of a system of forces, that the angular momentum h remains constant, while O moves along the direction of the linear momentum u , but changes, as O moves in any other direction; and finally, that its intensity will be a minimum and its direction coincident with that of u , when O lies upon a certain determinate line, which (from analogy) may be termed the *central axis of momenta*.

14. Now let us consider the changes in the linear and angular momenta, as the time changes, when the system is acted on by any forces.

In the time dt any force P generates in the particle on which it acts the momentum Pdt , and these momenta, being resolved and summed as was done above, will give rise to a linear momentum Rdt in the direction of the resultant force R of the forces (P), and an angular momentum Gdt relatively to the axis of the resultant couple G of the same forces. Since however the internal forces consist of pairs of equal and opposite forces in the same straight line, by the nature of action and reaction, the momenta produced by them will vanish in the

summation over the whole system; we may therefore regard R and G as the resultant force and resultant couple of the *external* forces. Then the linear momentum u along the line OU must be compounded with the linear momentum Rdt in the line OR in order to obtain its value at the time $t + dt$: and in like manner the angular momentum h relatively to the axis OH must be compounded with the angular momentum Gdt relatively to the axis OG .

15. Hence the method of the previous section applies to momenta of both kinds, replacing f in one case by R and in the other case by G . Thus the equations (B) give us

$$\frac{du}{dt} = R \cos RU, \quad u \frac{d\phi}{dt} = R \sin RU,$$

where $d\phi$ is the arc through which U moves towards R in the time dt : and

$$\frac{dh}{dt} = G \cos GH, \quad h \frac{d\psi}{dt} = G \sin GH,$$

where $d\psi$ is the arc through which H moves towards G in the time dt .

Also for fixed rectangular axes, with respect to which the components of R and G are X, Y, Z and L, M, N respectively, it is plain from the above reasoning that we should have

$$\begin{aligned} \frac{du_x}{dt} &= X, & \frac{du_y}{dt} &= Y, & \frac{du_z}{dt} &= Z, \\ \frac{dh_x}{dt} &= L, & \frac{dh_y}{dt} &= M, & \frac{dh_z}{dt} &= N, \end{aligned}$$

which are really the six fundamental equations of motion of our works on Dynamics.

For rectangular axes moveable about O , the equations (E) of the last section furnish two sets of three equations, of which the types are

$$\begin{aligned} \frac{du_x}{dt} &= X + u_y \Omega_z - u_z \Omega_y, \\ \frac{dh_x}{dt} &= L + h_y \Omega_z - h_z \Omega_y. \end{aligned}$$

16. If the system be acted on by no external forces, it follows that both u and h are constant in intensity and invariable in direction. This result might by analogy be named the principle of the *Conservation of Momentum*.

This principle, as applied to linear momentum, is obviously equivalent to the principle of the conservation of motion of the centre of gravity: as applied to angular momentum, the constancy of direction of the axis of h and therefore of a plane perpendicular to it shews that there is an invariable axis or plane, while the constancy of its intensity and therefore of its resolved part in any fixed direction is equivalent to the assertion of the truth of the principle of the conservation of areas for any fixed axis.

It may also be noted that there is an infinite number of invariable axes, and that, if the origin O be taken on the central axis of momenta, the corresponding invariable axis will coincide with the central axis, and the angular momentum about it will then be

a minimum: also that for any other position of the origin the direction of the invariable axis and the intensity of the momentum about it will depend upon the position of the line, parallel to the central axis, in which the origin lies, just as in the corresponding propositions relative to couples.

17. Any one of the different sets of equations in § (15) may be used to determine completely u and h , when the forces are given or vice versa. It is to be observed that the equations involving h , refer either to a fixed origin, or to an origin, whose motion is always in the instantaneous direction of u the linear momentum, for, as we saw, a change of the origin in this direction does not produce a change in h , as its change in any other direction does. It would be easy to introduce terms depending on the motion of the origin; in the last set of equations, for instance, if u_x, u_y, u_z denote the linear velocities of the origin in the directions of the axes, the equation for h_x becomes

$$\frac{dh_x}{dt} = L + h_y \Omega_z - h_z \Omega_y + u_y a_x - u_x a_y.$$

The equations involving u , are entirely independent of the origin, and will therefore not be affected, however the origin be supposed to move.

18. It appears then that the linear and angular momenta are determined solely by the *external forces* acting on the system, and not on the system itself otherwise than the forces themselves depend on it: in fact, they are simply the accumulated effects of the forces and the initial momenta. To proceed to the determination of the actual motion of the system from these momenta, the system must be particularised, and as one system may differ from another both as to the quantity of matter included in it, and as to its arrangement, we may consider separately how much farther particularisation in either respect will enable us to carry our results.

19. If the quantity of matter or mass of the whole system be given, it is well known that the linear momentum of the system is that of its whole mass collected at its centre of gravity, so that, M denoting this mass, the velocity of the centre of gravity is $\frac{u}{M}$ in the direction of the linear momentum: thus the motion of a certain point definitely related to the system is obtained, and this is usually regarded as defining its motion of translation. For any other point definitely related to the system, the motion will in general depend also on h and the arrangement of its matter.

20. If then the translation of the system be referred to its centre of gravity, its motion *about* the centre of gravity will depend solely on h and the *arrangement* of its mass; for the direction of motion of the centre of gravity being that of the linear momentum, h referred to that point as origin will be independent of u . Now the *arrangement* of a system of matter may be either permanent or variable. If the former, it is spoken of as a *body*

or *system of invariable form**, and the investigation of its motion *about* the centre of gravity requires only the determination of its axis of rotation and the intensity of rotation about that axis.

If the arrangement be *variable*, the laws of its variation must be given, and according to the number of possible laws will be the number of different solutions of the problem: here then the problem diverges into special problems; such as that of the motion of a body expanding or contracting according to a given law and the like, where the law of variation is *geometrically* expressed; and such as the problems of the motion of fluids, of elastic bodies, or of systems of bodies like the solar system, where the law of variation is *mechanically* expressed by defining the nature of the internal actions and reactions of the system. We shall confine our attention to the simpler problem of the motion of a system of invariable form, which we proceed to discuss.

21. The motion of an invariable system is always reducible to the motion of translation of some point invariably connected with it combined with a motion of rotation about a certain axis through that point. Let v_x, v_y, v_z denote the resolved velocities along Ox, Oy, Oz of the point O , to which the translation is referred, and let $\omega_x, \omega_y, \omega_z$ denote the resolved angular velocities about the same lines; then the velocity of any particle m , whose co-ordinates are x, y, z , is $v_x + \omega_y z - \omega_z y$ in the direction of Ox , with similar expressions for the directions Oy, Oz . Hence summing the linear and angular momenta of the several particles of the system, we find

$$u_x = \Sigma(m) \cdot v_x + \omega_y \cdot \Sigma(mz) - \omega_z \Sigma(my),$$

* I avoid the use of the term *rigid body* because of the *mechanical* notion conveyed in the term *rigid*. The propositions usually enunciated with reference to a *rigid* body must, if that term be retained, be understood of a *geometrically*, not a *mechanically*, rigid body; that is, of a body the disposition of whose parts is by hypothesis unaltered, not of one in which the disposition *cannot* be altered or can only be *insensibly* altered by force applied to it. But it is difficult (and perhaps not desirable) to divest this term of its mechanical meaning, as is seen in the modes of expression commonly adopted in the case of flexible strings, fluids, &c., where it is frequently demanded of us to suppose our strings to *become inflexible*, our fluids to *become rigid*, or to be enclosed in *rigid envelops*, and the like—a process which must always stagger a beginner and leave a certain want of confidence in his results, until this is gained by familiarity with the process, or until he learns that it simply amounts to asserting that what has been laid down to be true of a rigid body is no less true of a non-rigid body, while there is no change in the disposition of its parts. As another instance of a needless limitation in our current definitions, we may cite that of Statics as the science which treats of the *equilibrium* of forces, whereas the truer view would be to regard it as treating of those relations of forces which are *independent of time*, and thus every dynamical problem would have its *statical* part in which the *state* of the system and the forces is considered *at each instant*, and its truly *dynamical* part in which the changes effected *from instant to instant* are deter-

mined. This view presents Statics as a natural preparation for Dynamics, instead of as a science of co-ordinate rank separated by a gulf to be bridged over by a *fictitious* reduction of dynamical problems to problems of equilibrium through the introduction of *fictitious* forces. In several of our more recent works the terms *accelerating force* and *centrifugal force* have been rejected or explained as mere abbreviations, the one as not being properly a *force*, the other as being a *fictitious* and not an *actual* force: this it would be well to carry out still more completely, to restrict *force* in fact to that which is expressible by *weight* and to admit only *actual* forces (to the exclusion of *centrifugal forces*, *effective forces* and the like) under the two divisions of *internal* forces, or those whose opposite *Reactions* are included within the system, and *external* forces, or those whose opposite *Reactions* are not so included. If then Statics and Dynamics were defined as above, one great division of Rational Mechanics would be formed of the Statics and Dynamics of a system of given invariable form, without the particular constitution of the system being defined and therefore independent of *Internal Forces*; while the other great division would include the Statics and Dynamics of special systems of defined constitutions, as flexible bodies, fluids, elastic solids and the like, in which the laws of the *internal forces* must be more or less completely known. These remarks are thrown out as suggestions for a more *natural* system of grouping the special mechanical sciences than has yet been commonly received.

and
$$h_x = \Sigma m(y \cdot v_z + w_x y - w_y x - z \cdot v_y + w_z x - w_x z)$$

$$= \Sigma(my) \cdot v_z - \Sigma(mz) \cdot v_y + \Sigma(m \cdot y^2 + z^2) \cdot \omega_x - \Sigma(mxy)\omega_y - \Sigma(mzx) \cdot \omega_z,$$
with similar expressions for u_y, u_z and h_y, h_z .

From these equations it appears that, when the linear and angular velocities of the system are referred to an arbitrary point O , each depends in general on *both* the linear and the angular momentum. If however O be the centre of gravity, the linear velocity depends on the linear momentum only, and the angular velocity on the angular momentum only, for in this case $\Sigma(mx), \Sigma(my), \Sigma(mz)$ all vanish, and the equations become those, of which the types are

$$u_x = \Sigma(m) \cdot v_x,$$

$$h_x = \Sigma(my^2 + z^2)\omega_x - \Sigma(mxy) \cdot \omega_y - \Sigma(mzx)\omega_z.$$

22. Thus the motions of translation of the centre of gravity and of rotation about it are independent, a property which is true of no other point. Also it is to be observed that the direction of motion of the centre of gravity coincides with that of the linear momentum, while that of the axis of angular velocity does not in general coincide with that of the angular momentum. This is the cause of a greater complication in the problem of rotation than in that of translation. In the former the passage from momentum to velocity involves the changing of the direction of the axis as well as division by a quantity of the dimensions of a moment of inertia, whose value depends on the position of the momental axis in the system: in the latter the corresponding step involves simply division by a constant quantity, the mass, without change of direction. If the operation by which the step is taken from momentum to velocity, be considered as the *measure of the inertia*, we may express the above by stating that the measure of the inertia of a system relatively to translation (the centre of gravity* being the point of reference) is the mass of the system, and that the measure of its inertia relatively to rotation is not a simple numerically expressible magnitude, but, in Sir W. Hamilton's language, a *quaternion*, dependent on the position of the axis of angular momentum or of that of angular velocity in the system.

23. Confining our attention henceforth to the problem of rotation, we must first obtain a more distinct idea of the relation between the axes of angular momentum and velocity. We may obtain this from our previous equations for h_x, h_y, h_z , in their general form; but more simply when we consider our axes as coincident with the principal axes through the centre of gravity. If A, B, C denote the moments of inertia about these axes, the equations become (substituting 1, 2, 3 as subscripts for x, y, z respectively)

$$h_1 = A\omega_1, \quad h_2 = B\omega_2, \quad h_3 = C\omega_3;$$

hence the axis of angular momentum OH , whose equation is

$$\frac{x}{h_1} = \frac{y}{h_2} = \frac{z}{h_3},$$

is parallel to the normal to the central ellipsoid

* It will be observed that, if the translation be referred to any other point than the centre of gravity, the measure of inertia relatively to translation is also a quaternion.

$$Ax^2 + By^2 + Cz^2 = 1,$$

at the point, where the axis of angular velocity OI , whose equation is

$$\frac{x}{\omega_1} = \frac{y}{\omega_2} = \frac{z}{\omega_3},$$

meets it. Also reciprocally OI is parallel to the normal to the ellipsoid, whose equation is

$$\frac{x^2}{A} + \frac{y^2}{B} + \frac{z^2}{C} = 1,$$

at the point where OH meets it.

Thus a simple geometrical construction enables us to determine OI , when OH is given, and vice versa. If now ω be the angular velocity about OI , and I the moment of inertia about the same line, the angular momentum about it must be $I\omega$, since ω is the *total* angular velocity, and therefore the angular velocity about a line perpendicular to OI is zero; hence

$$I\omega = h \cdot \cos HI,$$

an equation connecting h and ω , the quantities I and HI being known when the above construction has been made.

24. If h be constant, and its direction OH invariable, it is plain from the above construction that OI will not in general remain fixed, nor ω constant, for, by the motion of the system about OI , the position of OH in the system is altered, and to this new position of OH a new position of OI will correspond, and then ω will change by reason of the variation of $\frac{\cos HI}{I}$. There is an exception however in the case where OH and OI coincide, for then the rotation does not change the position of OH in the system: this can only be the case when the radius OI of the central ellipsoid is also a normal, that is, when it coincides with one of the principal axes. Hence the principal axes are the only permanent axes of rotation of a body acted on by no forces (as is implied in our supposition of h being constant): in all other cases the axis of rotation moves in the body and in space, and the angular velocity about it varies.

25. If ω be constant and its axis OI fixed in the body, OH will also be fixed in the body, and h will be constant; but OH will then in general move in space, and the system must therefore be acted on by forces, whose resultant couple has its axis perpendicular to OH and in the plane of motion of OH . Hence the plane of the couple is HOI , if OI be fixed in space as well as in the body, and its moment is constant, since the velocity of OH is constant; thus the constraining couple on a body revolving uniformly about a fixed axis through its centre of gravity is determined.

In the exceptional case of a principal axis, OH is also fixed in space, and there is no constraining couple.

26. Before proceeding to the solution of the problem of a body's rotation about its centre of gravity by a method more in accordance with the plan of this paper, it will be well to shew how readily Euler's equations may be obtained from our principles.

If the moveable rectangular axes in § (15) be supposed fixed in the body and coincident with the principal axes, we must substitute

$$\omega_1, \omega_2, \omega_3 \text{ for } \Omega_x, \Omega_y, \Omega_z, \text{ and } h_1, h_2, h_3, \text{ or } A\omega_1, B\omega_2, C\omega_3 \text{ for } h_x, h_y, h_z,$$

and then we obtain three equations, of which the type is, either

$$\frac{dh_1}{dt} = L + \left(\frac{1}{C} - \frac{1}{B}\right)h_2h_3,$$

$$\text{or } A\frac{d\omega_1}{dt} = L + (B - C) \cdot \omega_2\omega_3.$$

The latter is the well known form of Euler's equations.

27. Instead of employing these equations, let us endeavour to solve our problem more directly. Our object is to determine the motion of OI , the axis of rotation, both in the body and in space, and the variation of ω , the angular velocity about it. This may be conceived to be due to an angular acceleration of definite intensity about a definite line; and this may be regarded as compounded of two similar accelerations, the one arising from the acceleration of momentum produced by the couple G about its axis OG , the other being the angular acceleration which would exist if no forces acted. Now the forces in the elementary time dt produce the angular momentum Gdt about OG , and this momentum gives rise to a corresponding angular velocity Kdt about an axis OK related to OG , just as OI is OH : thus the angular acceleration κ due to the forces is determined as to direction and intensity. The other component of the angular acceleration is in like manner due to a corresponding acceleration of momentum, which it is now necessary to determine.

28. Regard any line OP fixed in the body and moving with it by reason of the velocity ω about OI ; and apply equation (C) of section I., putting h for u ; therefore

$$\frac{dh_P}{dt} = -h\omega \cdot \sin IH \cdot \sin HP \cdot \sin IHP,$$

which determines the acceleration of momentum for any line OP . This acceleration will be zero, if OP be in the plane HOI , and a maximum, if OP be perpendicular to HOI , when its value is $h\omega \sin HI$: we may therefore regard the total acceleration* (f) due to the motion of the body as being about the line OF , perpendicular to HOI , and equal to $+h\omega \sin HI$, when OF is taken on that side of HOI on which a positive rotation about OF would move OH towards OI . Now to this acceleration of momentum (f) about OF will correspond an acceleration of angular velocity (λ) about a line OL which is related to OF , just as OI is to OH .

29. To sum up our results, we have shewn that, if OH be the axis of angular momentum (h) and OI that radius of the central ellipsoid at whose extremity the normal is parallel to OH , OI is the axis of angular velocity (ω): if OG be the axis of the impressed couple (G), and OK the radius for which the normal is parallel to OG , OK is the axis of angular accele-

* This result is that which M. Poinsot states thus: "The axis of the couple due to the centrifugal forces is perpendicular at once to the axis of rotation and to that of the 'couple d'impul-

tion.'"—M. Poinsot's "couple d'impulsion" is our *angular momentum*.

ration due to the forces (κ): lastly, if OF be perpendicular to the plane HOI , it is the axis of acceleration of angular momentum in the moving body, and OL , the radius for which the normal is parallel to OH , is the axis of angular acceleration due to the motion of the body (λ). Also we have the three equations for ω, κ, λ ,

$$\begin{aligned} I\omega &= h \cos HI, \\ K\kappa &= G \cos GK, \\ L\lambda &= f \cos FL, \end{aligned}$$

where $f = h\omega \sin HI$,

I, K, L denoting the moments of inertia about OI, OK, OL respectively. It will be observed that OI is the direction, to which the plane through O perpendicular to OH is diametral, and that OL is the direction to which the plane HOI is diametral, hence OL lies in the plane perpendicular to OH . Also if the rectangular planes HOI, FOL intersect in OM , it will be seen that the axes* OI, OL, OM are conjugate diameters of the central ellipsoid.

30. We will develop the solution in the simpler case of OG coinciding with OH and therefore OK with OI . In this case OH remains fixed in space, and the motion of OI is conveniently referred to its motion in the plane HOI and the motion of that plane about OH .

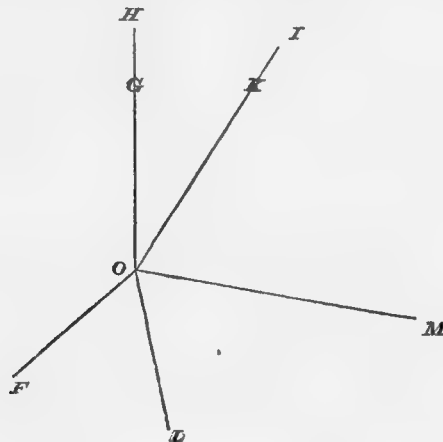

Let the conjugate radii OI, OL, OM be denoted by r, r', r'' , then the moments of inertia about them are $\frac{1}{r^2}, \frac{1}{r'^2}, \frac{1}{r''^2}$, by the property of the central ellipsoid: also let the angles HOI, FOL be denoted by θ, θ' : then our last equations become

$$(1) \quad \omega = hr^2 \cos \theta, \quad (2) \quad \kappa = Gr^2 \cos \theta, \quad (3) \quad \lambda = (h\omega \sin \theta) \cdot r'^2 \cos \theta'.$$

Resolve ω, κ, λ along the axes OH, OM, OF ; the component velocities are then $\omega \cos \theta$ along OH , $\omega \sin \theta$ along OM , and zero along OF , while the component accelerations are $\kappa \cos \theta$ along OH , $\kappa \sin \theta + \lambda \sin \theta'$ along OM , and $\lambda \cos \theta'$ along OF ; whence, by applying either the equation (C) or the equations (E),

$$\frac{d}{dt}(\omega \cos \theta) = \kappa \cos \theta = Gr^2 \cos^2 \theta, \dots \dots \dots (4)$$

* Hence if no forces act, the instantaneous motion of the axis of rotation OI will be towards OL , the radius with respect to which the plane HOI is diametral.

$$\frac{d}{dt}(\omega \sin \theta) = \kappa \sin \theta + \lambda \sin \theta' = Gr^2 \cos \theta \sin \theta + (h\omega \sin \theta) \cdot r'^2 \cos \theta' \sin \theta', \dots (5)$$

$$\omega \sin \theta \cdot \Omega = \lambda \cos \theta' = (h\omega \sin \theta) \cdot r'^2 \cos^2 \theta', \dots (6)$$

where Ω is the angular velocity of OM (*i. e.* of the plane HOI) about OH .

Also we have
$$\frac{dh}{dt} = G \dots (7)$$

Let p, p' denote the perpendiculars from O on the tangent planes to the central ellipsoid at I, L respectively, then $p = r \cos \theta, p' = r' \cos \theta'$.

Equation (4) becomes by (1) $\frac{d}{dt}(hp^2) = Gp^2$, whence by (7), p is constant. This shews that the tangent plane at I to the central ellipsoid is fixed, and that the central ellipsoid therefore rolls on it as a fixed plane.

Also by (4) and (5)

$$\frac{d(\tan \theta)}{dt} = \frac{d(\omega \sin \theta)}{dt(\omega \cos \theta)} = \frac{\lambda \sin \theta'}{\omega \cos \theta} = hp'^2 \tan \theta \cdot \tan \theta', \dots (8)$$

and from (6)
$$\Omega = hp'^2 \dots (9)$$

31. Now r, r', r'' being conjugate radii of the central ellipsoid, there exist three relations between them and the conjugate axes; these are, (putting $p \sec \theta, p' \sec \theta'$ for r, r' respectively and denoting the angle IOL by χ)

$$p^2 \sec^2 \theta + p'^2 \sec^2 \theta' + r''^2 = \frac{1}{A} + \frac{1}{B} + \frac{1}{C} = E, \text{ suppose,}$$

$$p^2 r''^2 + p'^2 r''^2 + p^2 p'^2 \sec^2 \theta \sec^2 \theta' \cdot \sin^2 \chi = \frac{1}{BC} + \frac{1}{CA} + \frac{1}{AB} = F, \text{ suppose,}$$

$$p^2 p'^2 r''^2 = \frac{1}{ABC} = G, \text{ suppose,}$$

and by reason of the rectangularity of the planes IOM, LOM , we have

$$\cos \chi = \sin \theta \sin \theta'.$$

Eliminating r'' and χ , we obtain

$$p^2 \sec^2 \theta + p'^2 \sec^2 \theta' + \frac{G}{p^2 p'^2} = E,$$

$$G \left(\frac{1}{p^2} + \frac{1}{p'^2} \right) + p^2 p'^2 (\sec^2 \theta + \sec^2 \theta' - 1) = F.$$

From these eliminating $\sec^2 \theta'$, we obtain

$$p'^2 = p^2 \left\{ 1 + \left(1 - \frac{E}{p^2} + \frac{F}{p^4} - \frac{G}{p^6} \right) \cot^2 \theta \right\},$$

which, (remembering what E, F, G denote, and putting α, β, γ for the three quantities

$$1 - \frac{1}{Ap^2}, 1 - \frac{1}{Bp^2}, 1 - \frac{1}{Cp^2} \text{ respectively)}$$

is equivalent to

$$p'^2 = p^2 (1 + \alpha \beta \gamma \cot^2 \theta);$$

also, since p', θ' are involved in precisely the same manner as p, θ , it follows that

$$p'^2 = p'^2(1 + \alpha'\beta'\gamma' \cot^2 \theta');$$

where α', β', γ' are what α, β, γ become, when p' is put for p .

From these equations we obtain

$$\cot^2 \theta' = - \frac{\alpha\beta\gamma}{\alpha'\beta'\gamma'} \frac{\cot^2 \theta}{1 + \alpha\beta\gamma \cot^2 \theta};$$

but
$$\alpha' = 1 - \frac{1}{Ap'^2} = 1 - \frac{1}{Ap^2} \cdot \frac{1}{1 + \alpha\beta\gamma \cot^2 \theta} = \alpha \frac{1 + \beta\gamma \cot^2 \theta}{1 + \alpha\beta\gamma \cot^2 \theta};$$

whence, with the corresponding expressions for β', γ' ,

$$\cot^2 \theta' = - \cot^2 \theta \cdot \frac{(1 + \alpha\beta\gamma \cot^2 \theta)^2}{(1 + \beta\gamma \cot^2 \theta)(1 + \gamma\alpha \cot^2 \theta)(1 + \alpha\beta \cot^2 \theta)},$$

hence p', θ' are known in terms of p, θ .

32. Substituting now for p', θ' in terms of p, θ , we obtain from equation (8)

$$\begin{aligned} \frac{d(\cot \theta)}{dt} &= hp'^2 \frac{\cot \theta}{\cot \theta'} \\ &= \pm hp^2 \left\{ - (1 + \beta\gamma \cot^2 \theta)(1 + \gamma\alpha \cot^2 \theta)(1 + \alpha\beta \cot^2 \theta) \right\}^{\frac{1}{2}}, \dots\dots\dots (10) \end{aligned}$$

and from equation (9)

$$\Omega = hp^2 (1 + \alpha\beta\gamma \cot^2 \theta).$$

If h be known by means of (7), these two equations determine completely the motion of OI the axis of angular velocity in altitude and azimuth, since p , and therefore α, β, γ , are constants.

If ϕ denote the azimuth at any instant, $\frac{d\phi}{dt} = \Omega$, and dividing the last equation by the preceding, we obtain a relation involving ϕ and θ only, which will therefore be the differential equation to the conical path of OI in space; and it is worth notice that, this relation being independent of h , the path of OI is the same whether the body be acted on by a couple whose axis coincides with OH , or whether it be acted on by no forces. The effect of the couple in this case is in fact only to alter the velocities of the different lines, not the paths which they describe.

Also equation (1) gives $\omega = hp^2 \sec \theta$, from which ω is known when θ is known by means of equation (10), and thus the velocity about OI is known completely as well as its position at any time.

33. If there be no forces acting, i. e. if $G = 0$, h is constant, as is also $\omega \cos \theta$, the resolved angular velocity of the body about OH . Also the *vis viva* of the body

$$= I\omega^2 = \frac{\omega^2}{r^2} = \frac{h^2 p^4}{r^2 \cos^2 \theta} = h^2 p^2,$$

and is therefore constant; and hence $\frac{\omega}{r}$ is constant, or $\omega \propto r$; both well known results. It may

also be well to note that $p^2 = \frac{\text{vis viva}}{(\text{angular momentum})^2}$, even if G do not vanish, and therefore that the vis viva $\propto (\text{angular momentum})^2$, when the angular momentum has a fixed direction.

It is needless to carry the solution farther by investigating the path of OI in the body, the position of the principal axes relatively to OH , OI at any time, &c., since all these questions are discussed with the utmost completeness and elegance in M. Poinsot's *Théorie de la Rotation*.

34. We will conclude this paper by solving the problems of Foucault's Gyroscope as applied to shew the effects of the earth's rotation, as it will furnish a good illustration of the advantages of the methods of this paper in enabling us to form our equations immediately with respect to the most convenient axes.

The Gyroscope is essentially a body, whose central ellipsoid is an oblate spheroid by reason of its two lesser principal moments being equal, and which is capable of moving freely about its centre of gravity. In this case, if a rapid rotation be communicated to it about its axis of unequal moment, that axis will evidently retain a fixed direction in space however the centre of gravity move, and therefore relatively to a place on the surface of the earth will alter its position just like a telescope, whose axis is always directed to the same star. But there are two other remarkable cases, where the motion about the centre of gravity is partially constrained; the first, where the axis of rotation is compelled to remain in the plane of the meridian, the second, when it is compelled to remain in the horizontal plane. These we will now consider.

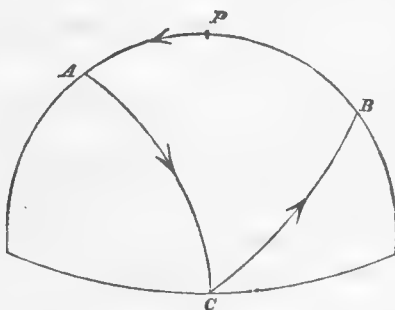

35. When the polar axis of the central spheroid always lies in the plane of the meridian, let θ denote the north polar distance of its extremity A . Let OB coincide with the equatorial axis in the plane of the meridian, and OC with that perpendicular to the same plane, and refer the motion to the axes OA , OB , OC . Now if Ω denote the angular velocity of the earth about its axis, the motions of OA , OB , OC will be due to the velocities $\Omega \cos \theta$, $\Omega \sin \theta$, $\frac{d\theta}{dt}$ about them respectively: also the actual velocities of the body about the same axes are respectively ω , $\Omega \sin \theta$, $\frac{d\theta}{dt}$, and the consequent angular momenta $A\omega$, $B\Omega \sin \theta$, $B\frac{d\theta}{dt}$, where ω , $\frac{d\theta}{dt}$, are reckoned positive when the motion about their axes is in the same direction as the earth's about its axis.

It is evident that in this case the constraint is equivalent to a couple, whose axis coincides with OB , let this be denoted by G . Then the equations (E) in the first section applied to the case before us give

$$\begin{aligned}\frac{d}{dt}(A\omega) &= B \frac{d\theta}{dt} \cdot \Omega \sin \theta - B\Omega \sin \theta \cdot \frac{d\theta}{dt} = 0, \\ \frac{d}{dt}(B\Omega \sin \theta) &= G + A\omega \cdot \frac{d\theta}{dt} - B \frac{d\theta}{dt} \cdot \Omega \cos \theta, \\ \frac{d}{dt}\left(B \frac{d\theta}{dt}\right) &= B\Omega \sin \theta \cdot \Omega \cos \theta - A\omega \cdot \Omega \sin \theta ;\end{aligned}$$

from the first equation, ω is constant, and from the last

$$\frac{d^2\theta}{dt^2} = - \left(\frac{A}{B}\omega - \Omega \cos \theta\right) \Omega \sin \theta ;$$

now in this case Ω the velocity of the earth's rotation is very small compared with ω , neglecting therefore the second term of this equation,

$$\frac{d^2\theta}{dt^2} = - \frac{A}{B} \omega \Omega \sin \theta,$$

whence the motion of the axis OA is precisely similar to that of the circular pendulum, whose length is l , where $\frac{g}{l} = \frac{A}{B} \omega \Omega$, and therefore $l = \frac{Bg}{A\omega\Omega}$, the direction of the earth's axis taking the place of the direction of the force of gravity.

Also since $\frac{d^2\theta}{dt^2} = 0$, when $\sin \theta = 0$, there are two positions of equilibrium of the axis OA , namely, when $\theta = 0$, and $\theta = \pi$: the former is stable and the latter unstable, when ω and Ω have the same sign. Hence the axis of rotation will remain at rest, if originally placed in the direction of the earth's axis, stably or unstably according as the rotation regarded from the end directed to the north pole is in the same direction, or the contrary, with the earth's rotation regarded from the same pole. If placed originally in any other position, it will oscillate about its position of stable equilibrium according to the same laws as a circular pendulum.

36. Next, let the polar axis OA always remain in the horizontal plane, and let ϕ denote its azimuth from the south towards the east. Taking OB and OC as before, the latter will now coincide with the vertical.

If c denote the co-latitude, Ω may be resolved into $\Omega \cos c$ vertical and $\Omega \sin c$ horizontal in the north direction: hence the angular velocities by which the axes move, are relatively to OA , OB , OC respectively

$$- \Omega \sin c \cos \phi, \quad - \Omega \sin c \sin \phi, \quad \frac{d\phi}{dt} + \Omega \cos c,$$

and the corresponding angular momenta are

$$A\omega, \quad - B\Omega \sin c \sin \phi, \quad B\left(\frac{d\phi}{dt} + \Omega \cos c\right),$$

whence as before,

$$\frac{d(A\omega)}{dt} = 0,$$

$$\frac{d}{dt}(-B\Omega \sin c \sin \phi) = G + A\omega \left(\frac{d\phi}{dt} + \cos c\right) + B\left(\frac{d\phi}{dt} + \Omega \cos c\right) \cdot \Omega \sin c \cos \phi,$$

$$\frac{d}{dt}\left(B\frac{d\phi}{dt} + \Omega \cos c\right) = B\Omega \sin c \sin \phi \cdot \Omega \sin c \cos \phi + A\omega \cdot \Omega \sin c \sin \phi,$$

and therefore ω is constant, and

$$\frac{d^2\phi}{dt^2} = \frac{A}{B} \omega \Omega \sin c \sin \phi + \Omega^2 \sin^2 c \cdot \sin \phi \cos \phi,$$

or approximately

$$\frac{d^2\phi}{dt^2} = \frac{A}{B} \omega \Omega \sin c \cdot \sin \phi;$$

whence, the rotation about OA being in the same direction seen from A as that of the earth seen from the north pole, it will be in a position of stable equilibrium when directed to the north, and of unstable equilibrium in the opposite position: also if originally directed in any other direction, it will oscillate about its position of stable equilibrium like a circular pendulum about the vertical whose length is $\frac{Bg}{A\omega\Omega \sin c}$.

DURHAM, Feb. 19, 1856.

R. B. H.

II. *On the question, What is the Solution of a Differential Equation? A Supplement to the third section of a paper, On some points of the Integral Calculus, printed in Vol. IX. Part II. By AUGUSTUS DE MORGAN, of Trinity College, Vice-President of the Royal Astronomical Society, and Professor of Mathematics in University College, London.*

[Read April 28, 1856.]

TRUSTING that it will be sufficient excuse for a very elementary paper, that writers of the highest character are not agreed with each other on a very elementary point, I beg to offer some remarks upon the usual solution of such an equation as $dy^2 - a^2 dx^2 = 0$, to which Euler assigns the integral form $(y - ax + b)(y + ax + c) = 0$, where b and c are independent constants. Most other writers insist on the condition $b = c$.

Lacroix refers only to Euler and to a paper by D'Alembert (*Berl. Mem.* 1748) which I have not seen. All the reasons which have been given on the subject are reducible, so far as I have met with them, to those which I shall cite from Lacroix himself and from Cauchy.

Lacroix (ii. 280) in his explanation of this case, and in defence of the substitution of $(y - ax + b)(y + ax + b)$ for $(y - ax + b)(y + ax + c)$, makes two remarks. The first,—chacun de ses facteurs doit être considéré isolément; the second, alluding to the form with two constants, is—on n'en tire pas d'autres lignes que celles qui résulteraient de l'intégrale renfermant une seule constante. M. Cauchy (*Moigno*, ii. 456) says—On ne restreindra pas la généralité de cette intégrale en désignant toutes les constantes arbitraires par la même lettre...: and grounds the right to do this on the possibility of thus obtaining *all* the curves which can satisfy the equation.

In searching out this matter, I found it by no means clearly laid down what is meant by the *solution of a differential equation*: and, on looking further, I found some degree of ambiguity attaching to the word *equation* itself. The following remarks will sufficiently explain what I mean.

A connexion between the values of letters, by which one is inevitably determined when the rest are given, may be called a *relation*. But an *equation* is the assertion of the equality of two expressions. Every simple explicit relation leads to an equation, to *one* equation: but every equation does not imply only *one* relation. The object of the problem being relation between y and x , the equation $(y - x)(y - x^2) = 0$ implies power of choice between the relations $y = x^2$, $y = x$. The equation $(y - x^2)(x - 1) = 0$ implies the relation $y = x^2$ with a *dispensation* from all relation in the case of $x = 1$.

Now I assert that in mathematical writings confusion between the equation and the simple relation is by no means infrequent: without dwelling on instances, I think we shall find, by

examining approved modes of reasoning, that the confusion cannot but be seen to have existed, so soon as the statement of what it consists in is made.

It is affirmed that the primitive of a primordial equation cannot have two arbitrary constants: but all that can be proved is that no such differential equation can have two *related* arbitrary constants in its primitive.

Let $f(x, y, y') = 0$ involve any number of relations between x, y, y' : and let $\phi(x, y, a, b) = 0$ be a relation between a and b , or any number of relations. Consequently, selecting one relation by which to satisfy $\phi = 0$, values of a and b can be found to satisfy both $\phi(x, y, a, b) = 0$, and also $\phi(x + h, y + k, a, b) = 0$, for any values of x, y, h, k . Hence, for any values of x and y , y' may have any value whatever: and this is incompatible with $f(x, y, y') = 0$. But this is no argument against any form of $\phi(x, y, a, b) = 0$, in which the constants are not in relation; as $\psi(x, y, a) \cdot \chi(x, y, b) = 0$. For we cannot pretend to satisfy

$$\psi(x, y, a) \cdot \chi(x, y, b) = 0, \quad \psi(x + h, y + k, a) \cdot \chi(x + h, y + k, b) = 0,$$

for any values of x, y, h, k , except by $\psi(x, y, a) = 0$, and $\chi(x + h, y + k, b) = 0$, or else by $\psi(x + h, y + k, a) = 0$, $\chi(x, y, b) = 0$. And from neither set can we deduce y' . If $\psi(x, y, a) = 0$ be a primitive of $f(x, y, y') = 0$, there appears nothing *à priori* to prevent our saying that $\psi(x, y, a) \cdot \psi(x, y, b) = 0$ is a primitive. This point will be presently examined.

It is affirmed that a primordial differential equation cannot have two really different primitives with an arbitrary constant in each: but all that can be proved is that one primordial *relation* cannot have two distinct primitives. If $y' = f(x, y)$ be satisfied by different relations $\phi(x, y, a) = 0$; $\psi(x, y, b) = 0$, then, taking a and b so as to satisfy both at a given point (x, y) , we find, generally, two values of y' at (x, y) . But $y' = f(x, y)$ may give these two values; irreducibly connected, as in $y' = 1 \pm \sqrt{y}$, or reducibly, as in $y' = 1 \pm \sqrt{y^2}$. The great point of algebraical interest, namely, that when the two values of y' are irreducibly connected $\phi = 0$ and $\psi = 0$ are the alternatives of an equation which can be rationalised or otherwise inverted into $\chi = 0$, where χ is of univocal form, is foreign to the present purpose. That purpose is, to make it clear that the common theorems about the singularity of the constant of integration must be transferred from differential *equations* to differential *relations*, of which one *equation* may contain any number.

The question whether $y = x^2$, which is certainly one relation for determination of y from x , is to be considered as giving *one* or *two* relations for determination of x from y , ends in a question of definition, perhaps, but ends in a question which cannot be adequately treated without a close attention to the meaning of the word *continuity*. And here immediately arises the distinction of permanence of *form* and continuity of *value*.

Form is expression of *modus operandi*: and permanence of form implies and is implied in permanence of the *modus operandi* through all *values* of the quantities to be operated on. In arithmetic, the signs $+$ or $-$ are of the form, and not of the value: but in algebra, the $+$ or $-$ which the *letter* carries in its signification are of the *value*, so called. Accordingly, permanence of form does not necessarily give continuity of value. The immediate passage of $\int_0^{\infty} \sin xv \cdot v^{-1} dv$ from $+\frac{1}{2}\pi$ to $-\frac{1}{2}\pi$, as x passes through 0, might be discovered by the

arithmetical computer, utterly ignorant of the Integral Calculus, by use of *skeleton forms* set up from one form of type. Nor does discontinuity of form necessarily give discontinuity of value. The branch of $y = x$ which ends at $x = 0$ joins the branch of $y = x + e^{-x^2}$ which begins at $x = 0$ with a contact of the order ∞ , as order of contact is usually defined. We may even propound the question whether $(-x)^2$ and $(+x)^2$ be not different *forms*?

Let continuity of no order, or *non-ordinal* continuity, be when and so long as infinitely small accessions to the variable give infinitely small accessions to the function. And let the passage from $\pm \infty$ to $\mp \infty$ be counted under this term. I will not, on this point, give more than an expression of my conviction that the word *continuity* must, by that dictation which has turned *unity* into a *number*, and its factor into a *multiplier*, be extended to contain the usual passage through infinity. Let *n-ordinal* continuity be when and so long as $y, y', y'', \dots y^{(n)}$ are of non-ordinal continuity.

These definitions being premised, we have in the passage from the positive to the negative value of $x^{\frac{1}{2}}$ an interminable continuity, and a change of form answering to, and indeed derived from, the change of form seen in $(+x)^2$ and $(-x)^2$. We have, in truth, all the *quantitative* properties of *one* relation, and all the *formal* properties of *two*. The attainment of a reducible case is the loss of the quantitative properties also: thus $(x^2 + a)^{\frac{1}{2}}$ is non-ordinally continuous, and not so much as primordially, when $a = 0$.

We are now in a condition to answer the question, What is the solution of a differential equation?—at least so far as having a clear view of the imperfect manner in which the question is put. We are obliged to ask in return, what requirements as to continuity are conveyed in the word *solution*?

1. The word *solution* may require the most absolute notion of permanence of form, not granting even the passage from $(-x)^2$ to $(+x)^2$. In this case we must be compelled to satisfy the differential equation by a relation of permanence equally strict, and in so many ways as we can do this, in so many ways can we announce a solution. Thus to $y'^2 = 2\sqrt{y} \cdot y'$ we announce three solutions. To $y' = 0$, any parallel to the axis of x . To $y' = 2 \times$ the positive value of \sqrt{y} , the right hand branch, from $x = a$ onwards, as figures are usually drawn, of any parabola $y = (x - a)^2$. To $y' = 2 \times$ the negative value of \sqrt{y} , the left hand branch of the same up to $x = a$. The change from any one of these to any other is entirely forbidden: and a must be less in one case, and greater in the other, than any value of x which is to be employed. Problems are frequently stated in a manner which will admit only one branch of an ordinary solution: and the investigator, so soon as this is perceived, generally widens his enunciation, rather than narrow his notion of a solution.

2. In a solution we may allow only such changes of form as take place in the inversions of ordinary algebra, and no others. In this case we should say, that we have $y = a$ and $y = (x - b)^2$, which we please, but only one, for the solution of $y'^2 = 2\sqrt{y} \cdot y'$. In this case and the last we satisfy Lacroix's requirement that the factors must be considered *in isolation*: but it is not correct to imply that such isolation is part of the meaning of a compound relation. From $PQ = 0$ we only learn that one of the two factors is to vanish: the equation has no power to deny us the use of one factor for some values of x , and of the other factor for others. The isolation of the factors is the postulation of a certain permanence of form.

3. In a solution we may allow change of form, with a given kind of continuity at the junction. If we mean to stipulate nothing whatever about continuity, we may at any value of x leave one curve, and proceed upon another. If we require non-ordinal continuity, we can only do this where two curves join each other. If we require *ordinal continuity* or continuity of the same order as the equation, we may propound as a solution of $y' = 2\sqrt{y}$ any number of parabolas with as much of the singular solution $y = 0$ as lies between their vertices. If we require every degree of continuity, we have, in the case before us, what is tantamount to requiring permanence of form, in its ordinary sense.

No prepossession derived from ordinary algebra would be offended by a solution which has a continuity of no higher order than the order of the equation itself: which would allow us, on arriving at the singular solution, or *connecting curve*, to break off from the curve thitherto employed, to proceed along any arc of the connecting curve, and to abandon this last at any chosen point in favour of the ordinary solution which there touches it.

In the graphical method by which the possibility of a solution is established, that is, by construction of a polygon from $\Delta y = \chi(x, y) \cdot \Delta x$, with a very small value of Δx , which may be as small as we please in the reasoning, a solution of $y' = \chi(x, y)$ is shewn to exist: but it may be one of the kind just alluded to. The draughtsman employed to construct such a solution, when his arc of the ordinary curve comes very near the point of contact with the singular solution, cannot undertake to remain on that ordinary curve, without reference to quantities of the second order. The accidents of paper and pencil are casualties of this order, which might divert his arc of solution from the ordinary curve on to the singular solution, might keep it there for a while, and then throw it off upon another ordinary solution. In fact, the solution established *à priori* has not of necessity permanence of form, but has only continuity of the order of the equation. And this remark applies to equations of all orders. In the case of $y' = 2\sqrt{y}$, when once a side of the polygon ends on $y = 0$, the draughtsman can never leave that line again, without constructing one side by help of $\Delta y = (\Delta x)^2$.

It may now be affirmed that $(y - ax + b)(y + ax + c) = 0$, b and c being perfectly independent constants, is a solution of $y'^2 - a^2 = 0$; nothing in the general theory of the primordial differential *relation* in any way withstanding. It remains to examine the assertion that the *generality* of this solution is not restricted by the supposition $b = c$.

To a certain extent this assertion is true: no more curves are obtained or included before the limitation than after it. Beyond this point the assertion is not true. The condition $b = c$ belongs to one mode of grouping a solution of $y' = a$ with a solution of $y' = -a$: but there is an infinite number of modes in $b = \phi c$. If ordinal continuity be held sufficient, and if $\phi(x, y, b) = 0$, $\psi(x, y, c) = 0$ be independent relations satisfying $f(x, y, y') = 0$, and if $P = 0$ be the most complete singular solution, then

$$P \cdot \phi(x, y, b_1) \cdot \phi(x, y, b_2) \dots \psi(x, y, c_1) \cdot \psi(x, y, c_2) \dots = 0$$

is the most general solution, where $b_1, b_2, \dots, c_1, c_2, \dots$ are in any number, and of any values. This however is but equivalent to $P \cdot \phi(x, y, b) \cdot \psi(x, y, c) = 0$ with the usual addition 'for any values whatever of b and c '.

This point will be best illustrated by reference to the biordinal equation and its theory. A primordial equation belongs to a group or family of curves which may be called of *single*

entry: a biordinal equation to a group of double entry, out of which an infinite number of groups of single entry may be collected. Thus, b and c being in relation in $\phi(x, y, b, c) = 0$, we may designate all the curves contained in $\phi(x, y, fc, c) = 0$ as the group (fc, c) . Generally speaking, the curves of the group (fc, c) are different from those of (Fc, c) . The unlimited number of cases of (fc, c) is the key to the unlimited number of primordinal equations which give rise to one and the same biordinal equation. It is then the characteristic of the biordinal equation that it represents a group of double entry. When the constants are not in relation, as in $\phi(x, y, b) \cdot \psi(x, y, c) = 0$, we have still groups of double entry, but the biordinal equation ceases to exist: the distinction between one group and another consists in the distinct ways in which individuals of the two groups $\phi = 0$ and $\psi = 0$ are joined together. This defective grouping—not defective in the variety of its cases, but defective in the variety of the elements out of which cases are to be compounded—is within the compass of a primordinal equation, into which therefore the biordinal equation degenerates.

As an instance, let $(P - b)(Q - c) + R = 0$, P, Q, R , being each a function of x and y : and let P' represent $P_x + P_y \cdot y'$, &c.

When $b = fc$, the primordinal equation of the group (fc, c) is

$$Q + \frac{R' + \sqrt{(R'^2 + 4P'Q'R)}}{2P'} = f \left\{ P + \frac{R' - \sqrt{(R'^2 + 4P'Q'R)}}{2Q'} \right\}.$$

Let $R = \mu V$, where V is a finite function, and μ a constant. When μ diminishes without limit, and finally vanishes, each primordinal equation becomes either $P' = 0$ or $Q' = 0$, for otherwise we have only $Q = fP$, the algebraic result of eliminating c between $(P - b)(Q - c) = 0$, and $(P - fc)Q' + (Q - c)P' = 0$. And the biordinal equation is determined by differentiating

$$b = Q + \frac{R' + \sqrt{(R'^2 + 4P'Q'R)}}{2P'}.$$

Do this fully, clear the result of fractions, and write μV for R : it will then appear that y'' is seen only in terms multiplied by positive powers of μ ; and so that $\mu = 0$ gives $P'Q' = 0$ in place of a biordinal equation.

The correction which the common theory requires is as follows;—An equation in which n constants are *in relation* with x and y , cannot have any differential equation clear of those constants under the n th order; and an equation of single and irreducible relation between $x, y, y', \dots, y^{(n)}$ must have a primitive containing n constants in relation to x and y . But a primitive equation in which n constants are contained in alternative relations, n_1 in one relation, n in a second, &c. does not require a differential equation of the n th order; but has an equation of alternative relations, one of the n_1 th order, one of the n_2 th order, &c.

From a primitive having n constants, in relation with x and y , no constants can be eliminated in favour of $y', y'',$ &c without one new equation of differentiation for every constant which is to disappear. But this is by no means true of constants in relation with x, y , and one or more of the set y', y'', \dots , to begin with. This point is made clear enough in the section of my former paper to which these remarks form a supplement: but the whole may be illustrated as follows. If $\phi(x, y, a) = 0$ give $a = \Phi(x, y)$, and therefore $\Phi_x + \Phi_y \cdot y' = 0$ for a differential equation, in which a has disappeared and y' is introduced, it is easy to give this differential

equation a primitive containing any number of separate and independent constants. For $A_0 + A_1 \Phi(x, y) + A_2 \{\Phi(x, y)\}^2 + \dots = 0$ cannot give any relation in which one of these constants disappears in favour of y' except $\Phi_x + \Phi_y \cdot y' = 0$, in which they all disappear. But this is merely formal; for $A_0 + A_1 \Phi(x, y) + \dots = 0$ is but a transformation of some case of $\Phi(x, y) = f(A_0, A_1, \dots)$ or of $\phi\{x, y, f(A_0, A_1, \dots)\} = 0$. All we have done, then, amounts to no more than use of the obvious theorem that a single arbitrary constant is equivalent to an arbitrary function of as many arbitrary constants as we please. Moreover, we may prove that $P + y'$ can only be a factor in the differential of one class of forms. If $\{F(x, y)\}'$ give $M(P + y')$, nothing but $\{\psi F(x, y)\}'$ can give $N(P + y')$: and $F(x, y) = \text{const.}$ and $\psi F(x, y) = \text{const.}$ are the same equations.

But it is otherwise with $P + y''$, P being a function of x, y, y' . This occurs, as previously shewn, in the differentiations of two distinct classes of forms. Thus $0 + y''$ is a factor in $\{f(xy' - y)\}'$ and in $\{Fy'\}'$. The equation

$$f(xy' - y) = A_0 + A_1 Fy' + A_2 \{Fy'\}^2 + \dots$$

is one which contains in every sense, formal and quantitative, as many arbitrary constants as we please; and an alteration in the value of one of them, is an alteration in the character of the relation subsisting between $xy' - y$ and y' . Nevertheless, it is impossible to get rid of any one constant in favour of y'' in any way except one which results in $y'' = 0$, an equation from which all the constants have disappeared.

Considerations similar to those which have been applied to primordial equations might also be applied to equations of any order.

A. DE MORGAN.

UNIVERSITY COLLEGE, LONDON,

March 29, 1856.

III. *On Faraday's Lines of Force.* By J. CLERK MAXWELL, B.A. *Fellow of Trinity College, Cambridge.*

[Read *Dec. 10, 1855,* and *Feb. 11, 1856.*]

THE present state of electrical science seems peculiarly unfavourable to speculation. The laws of the distribution of electricity on the surface of conductors have been analytically deduced from experiment; some parts of the mathematical theory of magnetism are established, while in other parts the experimental data are wanting; the theory of the conduction of galvanism and that of the mutual attraction of conductors have been reduced to mathematical formulæ, but have not fallen into relation with the other parts of the science. No electrical theory can now be put forth, unless it shews the connexion not only between electricity at rest and current electricity, but between the attractions and inductive effects of electricity in both states. Such a theory must accurately satisfy those laws, the mathematical form of which is known, and must afford the means of calculating the effects in the limiting cases where the known formulæ are inapplicable. In order therefore to appreciate the requirements of the science, the student must make himself familiar with a considerable body of most intricate mathematics, the mere retention of which in the memory materially interferes with further progress. The first process therefore in the effectual study of the science, must be one of simplification and reduction of the results of previous investigation to a form in which the mind can grasp them. The results of this simplification may take the form of a purely mathematical formula or of a physical hypothesis. In the first case we entirely lose sight of the phenomena to be explained; and though we may trace out the consequences of given laws, we can never obtain more extended views of the connexions of the subject. If, on the other hand, we adopt a physical hypothesis, we see the phenomena only through a medium, and are liable to that blindness to facts and rashness in assumption which a partial explanation encourages. We must therefore discover some method of investigation which allows the mind at every step to lay hold of a clear physical conception, without being committed to any theory founded on the physical science from which that conception is borrowed, so that it is neither drawn aside from the subject in pursuit of analytical subtleties, nor carried beyond the truth by a favourite hypothesis.

In order to obtain physical ideas without adopting a physical theory we must make ourselves familiar with the existence of physical analogies. By a physical analogy I mean that partial similarity between the laws of one science and those of another which makes each of them illustrate the other. Thus all the mathematical sciences are founded on relations between physical laws and laws of numbers, so that the aim of exact science is to reduce the problems of nature to the determination of quantities by operations with numbers. Passing from the most universal of all analogies to a very partial one, we find the same resemblance in mathematical form between two different phenomena giving rise to a physical theory of light.

The changes of direction which light undergoes in passing from one medium to another, are identical with the deviations of the path of a particle in moving through a narrow space in which intense forces act. This analogy, which extends only to the direction, and not to the velocity of motion, was long believed to be the true explanation of the refraction of light; and we still find it useful in the solution of certain problems, in which we employ it without danger, as an artificial method. The other analogy, between light and the vibrations of an elastic medium, extends much farther, but, though its importance and fruitfulness cannot be over-estimated, we must recollect that it is founded only on a resemblance *in form* between the laws of light and those of vibrations. By stripping it of its physical dress and reducing it to a theory of "transverse alternations," we might obtain a system of truth strictly founded on observation, but probably deficient both in the vividness of its conceptions and the fertility of its method. I have said thus much on the disputed questions of Optics, as a preparation for the discussion of the almost universally admitted theory of attraction at a distance.

We have all acquired the mathematical conception of these attractions. We can reason about them and determine their appropriate forms or formulæ. These formulæ have a distinct mathematical significance, and their results are found to be in accordance with natural phenomena. There is no formula in applied mathematics more consistent with nature than the formula of attractions, and no theory better established in the minds of men than that of the action of bodies on one another at a distance. The laws of the conduction of heat in uniform media appear at first sight among the most different in their physical relations from those relating to attractions. The quantities which enter into them are *temperature, flow of heat, conductivity*. The word *force* is foreign to the subject. Yet we find that the mathematical laws of the uniform motion of heat in homogeneous media are identical in form with those of attractions varying inversely as the square of the distance. We have only to substitute *source of heat* for *centre of attraction*, *flow of heat* for *accelerating effect of attraction* at any point, and *temperature* for *potential*, and the solution of a problem in attractions is transformed into that of a problem in heat.

This analogy between the formulæ of heat and attraction was, I believe, first pointed out by Professor William Thomson in the *Cambridge Math. Journal*, Vol. III.

Now the conduction of heat is supposed to proceed by an action between contiguous parts of a medium, while the force of attraction is a relation between distant bodies, and yet, if we knew nothing more than is expressed in the mathematical formulæ, there would be nothing to distinguish between the one set of phenomena and the other.

It is true, that if we introduce other considerations and observe additional facts, the two subjects will assume very different aspects, but the mathematical resemblance of some of their laws will remain, and may still be made useful in exciting appropriate mathematical ideas.

It is by the use of analogies of this kind that I have attempted to bring before the mind, in a convenient and manageable form, those mathematical ideas which are necessary to the study of the phenomena of electricity. The methods are generally those suggested by the processes of reasoning which are found in the researches of Faraday*, and which, though they have been interpreted mathematically by Prof. Thomson and others, are very generally supposed to be of an indefinite and unmathematical character, when compared with those employed by the professed mathematicians. By the method which I adopt, I hope to render it evident that I am not attempting to establish any physical theory of a science in which I have hardly made a single experiment, and that the limit of my design is to shew how, by a strict application of the ideas and methods of Faraday, the connexion of the very different orders of phenomena which he has discovered may be clearly placed before the mathematical mind. I shall therefore avoid as much as I can the introduction of anything which does not serve as a direct illustration of Faraday's methods, or of the mathematical deductions which may be made from them. In treating the simpler parts of the subject I shall use Faraday's mathematical methods as well as his ideas. When the complexity of the subject requires it, I shall use analytical notation, still confining myself to the development of ideas originated by the same philosopher.

I have in the first place to explain and illustrate the idea of "lines of force."

When a body is electrified in any manner, a small body charged with positive electricity, and placed in any given position, will experience a force urging it in a certain direction. If the small body be now negatively electrified, it will be urged by an equal force in a direction exactly opposite.

The same relations hold between a magnetic body and the north or south poles of a small magnet. If the north pole is urged in one direction, the south pole is urged in the opposite direction.

In this way we might find a line passing through any point of space, such that it represents the direction of the force acting on a positively electrified particle, or on an elementary north pole, and the reverse direction of the force on a negatively electrified particle or an elementary south pole. Since at every point of space such a direction may be found, if we commence at any point and draw a line so that, as we go along it, its direction at any point shall always coincide with that of the resultant force at that point, this curve will indicate the direction of that force for every point through which it passes, and might be called on that account a *line of force*. We might in the same way draw other lines of force, till we had filled all space with curves indicating by their direction that of the force at any assigned point.

* See especially Series XXXVIII. of the *Experimental Researches*, and *Phil. Mag.* 1852.

We should thus obtain a geometrical model of the physical phenomena, which would tell us the *direction* of the force, but we should still require some method of indicating the *intensity* of the force at any point. If we consider these curves not as mere lines, but as fine tubes of variable section carrying an incompressible fluid, then, since the velocity of the fluid is inversely as the section of the tube, we may make the velocity vary according to any given law, by regulating the section of the tube, and in this way we might represent the intensity of the force as well as its direction by the motion of the fluid in these tubes. This method of representing the intensity of a force by the velocity of an imaginary fluid in a tube is applicable to any conceivable system of forces, but it is capable of great simplification in the case in which the forces are such as can be explained by the hypothesis of attractions varying inversely as the square of the distance, such as those observed in electrical and magnetic phenomena. In the case of a perfectly arbitrary system of forces, there will generally be interstices between the tubes; but in the case of electric and magnetic forces it is possible to arrange the tubes so as to leave no interstices. The tubes will then be mere surfaces, directing the motion of a fluid filling up the whole space. It has been usual to commence the investigation of the laws of these forces by at once assuming that the phenomena are due to attractive or repulsive forces acting between certain points. We may however obtain a different view of the subject, and one more suited to our more difficult inquiries, by adopting for the definition of the forces of which we treat, that they may be represented in magnitude and direction by the uniform motion of an incompressible fluid.

I propose, then, first to describe a method by which the motion of such a fluid can be clearly conceived; secondly to trace the consequences of assuming certain conditions of motion, and to point out the application of the method to some of the less complicated phenomena of electricity, magnetism, and galvanism; and lastly to shew how by an extension of these methods, and the introduction of another idea due to Faraday, the laws of the attractions and inductive actions of magnets and currents may be clearly conceived, without making any assumptions as to the physical nature of electricity, or adding anything to that which has been already proved by experiment.

By referring everything to the purely geometrical idea of the motion of an imaginary fluid, I hope to attain generality and precision, and to avoid the dangers arising from a premature theory professing to explain the cause of the phenomena. If the results of mere speculation which I have collected are found to be of any use to experimental philosophers, in arranging and interpreting their results, they will have served their purpose, and a mature theory, in which physical facts will be physically explained, will be formed by those who by interrogating Nature herself can obtain the only true solution of the questions which the mathematical theory suggests.

I. *Theory of the Motion of an incompressible Fluid.*

(1) The substance here treated of must not be assumed to possess any of the properties of ordinary fluids except those of freedom of motion and resistance to compression. It is not

even a hypothetical fluid which is introduced to explain actual phenomena. It is merely a collection of imaginary properties which may be employed for establishing certain theorems in pure mathematics in a way more intelligible to many minds and more applicable to physical problems than that in which algebraic symbols alone are used. The use of the word "Fluid" will not lead us into error, if we remember that it denotes a purely imaginary substance with the following property :

The portion of fluid which at any instant occupied a given volume, will at any succeeding instant occupy an equal volume.

This law expresses the incompressibility of the fluid, and furnishes us with a convenient measure of its quantity, namely its volume. The unit of quantity of the fluid will therefore be the unit of volume.

(2) The direction of motion of the fluid will in general be different at different points of the space which it occupies, but since the direction is determinate for every such point, we may conceive a line to begin at any point and to be continued so that every element of the line indicates by its direction the direction of motion at that point of space. Lines drawn in such a manner that their direction always indicates the direction of fluid motion are called *lines of fluid motion*.

If the motion of the fluid be what is called *steady motion*, that is, if the direction and velocity of the motion at any fixed point be independent of the time, these curves will represent the paths of individual particles of the fluid, but if the motion be variable this will not generally be the case. The cases of motion which will come under our notice will be those of steady motion.

(3) If upon any surface which cuts the lines of fluid motion we draw a closed curve, and if from every point of this curve we draw a line of motion, these lines of motion will generate a tubular surface which we may call a *tube of fluid motion*. Since this surface is generated by lines in the direction of fluid motion no part of the fluid can flow across it, so that this imaginary surface is as impermeable to the fluid as a real tube.

(4) The quantity of fluid which in unit of time crosses any fixed section of the tube is the same at whatever part of the tube the section be taken. For the fluid is incompressible, and no part runs through the sides of the tube, therefore the quantity which escapes from the second section is equal to that which enters through the first.

If the tube be such that unit of volume passes through any section in unit of time it is called a *unit tube of fluid motion*.

(5) In what follows, various units will be referred to, and a finite number of lines or surfaces will be drawn, representing in terms of those units the motion of the fluid. Now in order to define the motion in every part of the fluid, an infinite number of lines would have to be drawn at indefinitely small intervals; but since the description of such a system of lines would involve continual reference to the theory of limits, it has been thought better to suppose

the lines drawn at intervals depending on the assumed unit, and afterwards to assume the unit as small as we please by taking a small submultiple of the standard unit.

(6) To define the motion of the whole fluid by means of a system of unit tubes.

Take any fixed surface which cuts all the lines of fluid motion, and draw upon it any system of curves not intersecting one another. On the same surface draw a second system of curves intersecting the first system, and so arranged that the quantity of fluid which crosses the surface within each of the quadrilaterals formed by the intersection of the two systems of curves shall be unity in unit of time. From every point in a curve of the first system let a line of fluid motion be drawn. These lines will form a surface through which no fluid passes. Similar impermeable surfaces may be drawn for all the curves of the first system. The curves of the second system will give rise to a second system of impermeable surfaces, which, by their intersection with the first system, will form quadrilateral tubes, which will be tubes of fluid motion. Since each quadrilateral of the cutting surface transmits unity of fluid in unity of time, every tube in the system will transmit unity of fluid through any of its sections in unit of time. The motion of the fluid at every part of the space it occupies is determined by this system of unit tubes; for the direction of motion is that of the tube through the point in question, and the velocity is the reciprocal of the area of the section of the unit tube at that point.

(7) We have now obtained a geometrical construction which completely defines the motion of the fluid by dividing the space it occupies into a system of unit tubes. We have next to shew how by means of these tubes we may ascertain various points relating to the motion of the fluid.

A unit tube may either return into itself, or may begin and end at different points, and these may be either in the boundary of the space in which we investigate the motion, or within that space. In the first case there is a continual circulation of fluid in the tube, in the second the fluid enters at one end and flows out at the other. If the extremities of the tube are in the bounding surface, the fluid may be supposed to be continually supplied from without from an unknown source, and to flow out at the other into an unknown reservoir; but if the origin of the tube or its termination be within the space under consideration, then we must conceive the fluid to be supplied by a *source* within that space, capable of creating and emitting unity of fluid in unity of time, and to be afterwards swallowed up by a *sink* capable of receiving and destroying the same amount continually.

There is nothing self-contradictory in the conception of these sources where the fluid is created, and sinks where it is annihilated. The properties of the fluid are at our disposal, we have made it incompressible, and now we suppose it produced from nothing at certain points and reduced to nothing at others. The places of production will be called *sources*, and their numerical value will be the number of units of fluid which they produce in unit of time. The places of reduction will, for want of a better name, be called *sinks*, and will be estimated by the number of units of fluid absorbed in unit of time. Both places will sometimes be called *sources*, a source being understood to be a sink when its sign is negative.

(8) It is evident that the amount of fluid which passes any fixed surface is measured by the number of unit tubes which cut it, and the direction in which the fluid passes is determined by that of its motion in the tubes. If the surface be a closed one, then any tube whose terminations lie on the same side of the surface must cross the surface as many times in the one direction as in the other, and therefore must carry as much fluid out of the surface as it carries in. A tube which begins within the surface and ends without it will carry out unity of fluid; and one which enters the surface and terminates within it will carry in the same quantity. In order therefore to estimate the amount of fluid which flows out of the closed surface, we must subtract the number of tubes which end within the surface from the number of tubes which begin there. If the result is negative the fluid will on the whole flow inwards.

If we call the beginning of a unit tube a unit source, and its termination a unit sink, then the quantity of fluid produced within the surface is estimated by the number of unit sources minus the number of unit sinks, and this must flow out of the surface on account of the incompressibility of the fluid.

In speaking of these unit tubes, sources and sinks, we must remember what was stated in (5) as to the magnitude of the unit, and how by diminishing their size and increasing their number we may distribute them according to any law however complicated.

(9) If we know the direction and velocity of the fluid at any point in two different cases, and if we conceive a third case in which the direction and velocity of the fluid at any point is the resultant of the velocities in the two former cases at corresponding points, then the amount of fluid which passes a given fixed surface in the third case will be the algebraic sum of the quantities which pass the same surface in the two former cases. For the rate at which the fluid crosses any surface is the resolved part of the velocity normal to the surface, and the resolved part of the resultant is equal to the sum of the resolved parts of the components.

Hence the number of unit tubes which cross the surface outwards in the third case must be the algebraical sum of the numbers which cross it in the two former cases, and the number of sources within any closed surface will be the sum of the numbers in the two former cases. Since the closed surface may be taken as small as we please, it is evident that the distribution of sources and sinks in the third case arises from the simple superposition of the distributions in the two former cases.

II. *Theory of the uniform motion of an imponderable incompressible fluid through a resisting medium.*

(10) The fluid is here supposed to have no inertia, and its motion is opposed by the action of a force which we may conceive to be due to the resistance of a medium through which the fluid is supposed to flow. This resistance depends on the nature of the medium, and will in general depend on the direction in which the fluid moves, as well as on its velocity. For the present we may restrict ourselves to the case of a uniform medium, whose resistance is the same in all directions. The law which we assume is as follows.

Any portion of the fluid moving through the resisting medium is directly opposed by a retarding force proportional to its velocity.

If the velocity be represented by v , then the resistance will be a force equal to kv acting on unit of volume of the fluid in a direction contrary to that of motion. In order, therefore, that the velocity may be kept up, there must be a greater pressure behind any portion of the fluid than there is in front of it, so that the difference of pressures may neutralise the effect of the resistance. Conceive a cubical unit of fluid (which we may make as small as we please, by (5)), and let it move in a direction perpendicular to two of its faces. Then the resistance will be kv , and therefore the difference of pressures on the first and second faces is kv , so that the pressure diminishes in the direction of motion at the rate of kv for every unit of length measured along the line of motion; so that if we measure a length equal to h units, the difference of pressure at its extremities will be kvh .

(11) Since the pressure is supposed to vary continuously in the fluid, all the points at which the pressure is equal to a given pressure p will lie on a certain surface which we may call the *surface* (p) *of equal pressure*. If a series of these surfaces be constructed in the fluid corresponding to the pressures 0, 1, 2, 3 &c., then the number of the surface will indicate the pressure belonging to it, and the surface may be referred to as the surface 0, 1, 2 or 3. The unit of pressure is that pressure which is produced by unit of force acting on unit of surface. In order therefore to diminish the unit of pressure as in (5) we must diminish the unit of force in the same proportion.

(12) It is easy to see that these surfaces of equal pressure must be perpendicular to the lines of fluid motion; for if the fluid were to move in any other direction, there would be a resistance to its motion which could not be balanced by any difference of pressures. (We must remember that the fluid here considered has no inertia or mass, and that its properties are those only which are formally assigned to it, so that the resistances and pressures are the only things to be considered.) There are therefore two sets of surfaces which by their intersection form the system of unit tubes, and the system of surfaces of equal pressure cuts both the others at right angles. Let h be the distance between two consecutive surfaces of equal pressure measured along a line of motion, then since the difference of pressures = 1,

$$kvh = 1,$$

which determines the relation of v to h , so that one can be found when the other is known. Let s be the sectional area of a unit tube measured on a surface of equal pressure, then since by the definition of a unit tube

$$vs = 1,$$

we find by the last equation

$$s = kh.$$

(13) The surfaces of equal pressure cut the unit tubes into portions whose length is h and section s . These elementary portions of unit tubes will be called *unit cells*. In each of them unity of volume of fluid passes from a pressure p to a pressure ($p-1$) in unit of time, and therefore overcomes unity of resistance in that time. The work spent in overcoming resistance is therefore unity in every cell in every unit of time.

(14) If the surfaces of equal pressure are known, the direction and magnitude of the velocity of the fluid at any point may be found, after which the complete system of unit tubes may be constructed, and the beginnings and endings of these tubes ascertained and marked out as the sources whence the fluid is derived, and the sinks where it disappears. In order to prove the converse of this, that if the distribution of sources be given, the pressure at every point may be found, we must lay down certain preliminary propositions.

(15) If we know the pressures at every point in the fluid in two different cases, and if we take a third case in which the pressure at any point is the sum of the pressures at corresponding points in the two former cases, then the velocity at any point in the third case is the resultant of the velocities in the other two, and the distribution of sources is that due to the simple superposition of the sources in the two former cases.

For the velocity in any direction is proportional to the rate of decrease of the pressure in that direction; so that if two systems of pressures be added together, since the rate of decrease of pressure along any line will be the sum of the combined rates, the velocity in the new system resolved in the same direction will be the sum of the resolved parts in the two original systems. The velocity in the new system will therefore be the resultant of the velocities at corresponding points in the two former systems.

It follows from this, by (9), that the quantity of fluid which crosses any fixed surface is, in the new system, the sum of the corresponding quantities in the old ones, and that the sources of the two original systems are simply combined to form the third.

It is evident that in the system in which the pressure is the difference of pressure in the two given systems the distribution of sources will be got by changing the sign of all the sources in the second system and adding them to those in the first.

(16) If the pressure at every point of a closed surface be the same and equal to p , and if there be no sources or sinks within the surface, then there will be no motion of the fluid within the surface, and the pressure within it will be uniform and equal to p .

For if there be motion of the fluid within the surface there will be tubes of fluid motion, and these tubes must either return into themselves or be terminated either within the surface or at its boundary. Now since the fluid always flows from places of greater pressure to places of less pressure, it cannot flow in a re-entering curve; since there are no sources or sinks within the surface, the tubes cannot begin or end except on the surface; and since the pressure at all points of the surface is the same, there can be no motion in tubes having both extremities on the surface. Hence there is no motion within the surface, and therefore no difference of pressure which would cause motion, and since the pressure at the bounding surface is p , the pressure at any point within it is also p .

(17) If the pressure at every point of a given closed surface be known, and the distribution of sources within the surface be also known, then only one distribution of pressures can exist within the surface.

For if two different distributions of pressures satisfying these conditions could be found, a third distribution could be formed in which the pressure at any point should be the

difference of the pressures in the two former distributions. In this case, since the pressures at the surface and the sources within it are the same in both distributions, the pressure at the surface in the third distribution would be zero, and all the sources within the surface would vanish, by (15).

Then by (16) the pressure at every point in the third distribution must be zero; but this is the difference of the pressures in the two former cases, and therefore these cases are the same, and there is only one distribution of pressure possible.

(18) Let us next determine the pressure at any point of an infinite body of fluid in the centre of which a unit source is placed, the pressure at an infinite distance from the source being supposed to be zero.

The fluid will flow out from the centre symmetrically, and since unity of volume flows out of every spherical surface surrounding the point in unit of time, the velocity at a distance r from the source will be

$$v = \frac{1}{4\pi r^2}.$$

The rate of decrease of pressure is therefore kv or $\frac{k}{4\pi r^2}$, and since the pressure = 0 when r is infinite, the actual pressure at any point will be $p = \frac{k}{4\pi r}$.

The pressure is therefore inversely proportional to the distance from the source. It is evident that the pressure due to a unit sink will be negative and equal to

$$-\frac{k}{4\pi r}.$$

If we have a source formed by the coalition of S unit sources, then the resulting pressure will be $p = \frac{kS}{4\pi r}$, so that the pressure at a given distance varies as the resistance and number of sources conjointly.

(19) If a number of sources and sinks coexist in the fluid, then in order to determine the resultant pressure we have only to add the pressures which each source or sink produces. For by (15) this will be a solution of the problem, and by (17) it will be the only one. By this method we can determine the pressures due to any distribution of sources, as by the method of (14) we can determine the distribution of sources to which a given distribution of pressures is due.

(20) We have next to shew that if we conceive any imaginary surface as fixed in space and intersecting the lines of motion of the fluid, we may substitute for the fluid on one side of this surface a distribution of sources upon the surface itself without altering in any way the motion of the fluid on the other side of the surface.

For if we describe the system of unit tubes which defines the motion of the fluid, and wherever a tube enters through the surface place a unit source, and wherever a tube goes out through the surface place a unit sink, and at the same time render the surface impermeable to the fluid, the motion of the fluid in the tubes will go on as before.

(21) If the system of pressures and the distribution of sources which produce them be known in a medium whose resistance is measured by k , then in order to produce the same system of pressures in a medium whose resistance is unity, the rate of production at each source must be multiplied by k . For the pressure at any point due to a given source varies as the rate of production and the resistance conjointly; therefore if the pressure be constant, the rate of production must vary inversely as the resistance.

(22) *On the conditions to be fulfilled at a surface which separates two media whose coefficients of resistance are k and k' .*

These are found from the consideration, that the quantity of fluid which flows out of the one medium at any point flows into the other, and that the pressure varies continuously from one medium to the other. The velocity normal to the surface is the same in both media, and therefore the rate of diminution of pressure is proportional to the resistance. The direction of the tubes of motion and the surfaces of equal pressure will be altered after passing through the surface, and the law of this refraction will be, that it takes place in the plane passing through the direction of incidence and the normal to the surface, and that the tangent of the angle of incidence is to the tangent of the angle of refraction as k' is to k .

(23) Let the space within a given closed surface be filled with a medium different from that exterior to it, and let the pressures at any point of this compound system due to a given distribution of sources within and without the surface be given; it is required to determine a distribution of sources which would produce the same system of pressures in a medium whose coefficient of resistance is unity.

Construct the tubes of fluid motion, and wherever a unit tube enters either medium place a unit source, and wherever it leaves it place a unit sink. Then if we make the surface impermeable all will go on as before.

Let the resistance of the exterior medium be measured by k , and that of the interior by k' . Then if we multiply the rate of production of all the sources in the exterior medium (including those in the surface), by k , and make the coefficient of resistance unity, the pressures will remain as before, and the same will be true of the interior medium if we multiply all the sources in it by k' , including those in the surface, and make its resistance unity.

Since the pressures on both sides of the surface are now equal, we may suppose it permeable if we please.

We have now the original system of pressures produced in a uniform medium by a combination of three systems of sources. The first of these is the given external system multiplied by k , the second is the given internal system multiplied by k' , and the third is the system of sources and sinks on the surface itself. In the original case every source in the external medium had an equal sink in the internal medium on the other side of the surface, but now the source is multiplied by k and the sink by k' , so that the result is for every external unit source on the surface, a source = $(k - k')$. By means of these three systems of sources the original system of pressures may be produced in a medium for which $k = 1$.

(24) Let there be no resistance in the medium within the closed surface, that is, let $k' = 0$, then the pressure within the closed surface is uniform and equal to p , and the pressure at the surface itself is also p . If by assuming any distribution of pairs of sources and sinks within the surface in addition to the given external and internal sources, and by supposing the medium the same within and without the surface, we can render the pressure at the surface uniform, the pressures so found for the external medium, together with the uniform pressure p in the internal medium, will be the true and only distribution of pressures which is possible.

For if two such distributions could be found by taking different imaginary distributions of pairs of sources and sinks within the medium, then by taking the difference of the two for a third distribution, we should have the pressure of the bounding surface constant in the new system and as many sources as sinks within it, and therefore whatever fluid flows in at any point of the surface, an equal quantity must flow out at some other point.

In the external medium all the sources destroy one another, and we have an infinite medium without sources surrounding the internal medium. The pressure at infinity is zero, that at the surface is constant. If the pressure at the surface is positive, the motion of the fluid must be outwards from every point of the surface; if it be negative, it must flow inwards towards the surface. But it has been shewn that neither of these cases is possible, because if any fluid enters the surface an equal quantity must escape, and therefore the pressure at the surface is zero in the third system.

The pressure at all points in the boundary of the internal medium in the third case is therefore zero, and there are no sources, and therefore the pressure is everywhere zero, by (16).

The pressure in the bounding surface of the internal medium is also zero, and there is no resistance, therefore it is zero throughout; but the pressure in the third case is the difference of pressures in the two given cases, therefore these are equal, and there is only one distribution of pressure which is possible, namely, that due to the imaginary distribution of sources and sinks.

(25) When the resistance is infinite in the internal medium, there can be no passage of fluid through it or into it. The bounding surface may therefore be considered as impermeable to the fluid, and the tubes of fluid motion will run along it without cutting it.

If by assuming any arbitrary distribution of sources within the surface in addition to the given sources in the outer medium, and by calculating the resulting pressures and velocities as in the case of a uniform medium, we can fulfil the condition of there being no velocity across the surface, the system of pressures in the outer medium will be the true one. For since no fluid passes through the surface, the tubes in the interior are independent of those outside, and may be taken away without altering the external motion.

(26) If the extent of the internal medium be small, and if the difference of resistance in the two media be also small, then the position of the unit tubes will not be much altered from what it would be if the external medium filled the whole space.

On this supposition we can easily calculate the kind of alteration which the introduction of the internal medium will produce; for wherever a unit tube enters the surface we must conceive a source producing fluid at a rate $\frac{k' - k}{k}$, and wherever a tube leaves it we must place a sink annihilating fluid at the rate $\frac{k' - k}{k}$, then calculating pressures on the supposition that the resistance in both media is k the same as in the external medium, we shall obtain the true distribution of pressures very approximately, and we may get a better result by repeating the process on the system of pressures thus obtained.

(27) If instead of an abrupt change from one coefficient of resistance to another we take a case in which the resistance varies continuously from point to point, we may treat the medium as if it were composed of thin shells each of which has uniform resistance. By properly assuming a distribution of sources over the surfaces of separation of the shells, we may treat the case as if the resistance were equal to unity throughout, as in (23). The sources will then be distributed continuously throughout the whole medium, and will be positive whenever the motion is from places of less to places of greater resistance, and negative when in the contrary direction.

(28) Hitherto we have supposed the resistance at a given point of the medium to be the same in whatever direction the motion of the fluid takes place; but we may conceive a case in which the resistance is different in different directions. In such cases the lines of motion will not in general be perpendicular to the surfaces of equal pressure. If a, b, c be the components of the velocity at any point, and α, β, γ the components of the resistance at the same point, these quantities will be connected by the following system of linear equations, which may be called "*equations of conduction,*" and will be referred to by that name.

$$\begin{aligned} a &= P_1 a + Q_3 \beta + R_2 \gamma, \\ b &= P_2 \beta + Q_1 \gamma + R_3 a, \\ c &= P_3 \gamma + Q_2 a + R_1 \beta. \end{aligned}$$

In these equations there are nine independent coefficients of conductivity. In order to simplify the equations, let us put

$$\begin{aligned} Q_1 + R_1 &= 2S_1, & Q_1 - R_1 &= 2lT, \\ & \dots\dots\dots \&c. & \dots\dots\dots \&c. \end{aligned}$$

where $4T^2 = (Q_1 - R_1)^2 + (Q_2 - R_2)^2 + (Q_3 - R_3)^2$,
and l, m, n are direction cosines of a certain fixed line in space.

The equations then become

$$\begin{aligned} a &= P_1 a + S_3 \beta + S_2 \gamma + (n\beta - m\gamma)T, \\ b &= P_2 \beta + S_1 \gamma + S_3 a + (l\gamma - n\alpha)T, \\ c &= P_3 \gamma + S_2 a + S_1 \beta - (m\alpha - l\beta)T. \end{aligned}$$

By the ordinary transformation of coordinates we may get rid of the coefficients marked S . The equations then become

$$\begin{aligned} a &= P_1' a + (n'\beta - m'\gamma)T, \\ b &= P_2' \beta + (l'\gamma - n'\alpha)T, \\ c &= P_3' \gamma + (m'\alpha - l'\beta)T, \end{aligned}$$

where l' , m' , n' are the direction cosines of the fixed line with reference to the new axes. If we make

$$x = \frac{dp}{dx}, \quad y = \frac{dp}{dy}, \quad \text{and } z = \frac{dp}{dz},$$

the equation of continuity

$$\frac{da}{dx} + \frac{db}{dy} + \frac{dc}{dz} = 0,$$

becomes

$$P_1' \frac{d^2 p}{dx^2} + P_2' \frac{d^2 p}{dy^2} + P_3' \frac{d^2 p}{dz^2} = 0,$$

and if we make

$$x = \sqrt{P_1'} \xi, \quad y = \sqrt{P_2'} \eta, \quad z = \sqrt{P_3'} \zeta,$$

then

$$\frac{d^2 p}{d\xi^2} + \frac{d^2 p}{d\eta^2} + \frac{d^2 p}{d\zeta^2} = 0,$$

the ordinary equation of conduction.

It appears therefore that the distribution of pressures is not altered by the existence of the coefficient T . Professor Thomson has shewn how to conceive a substance in which this coefficient determines a property having reference to an axis, which unlike the axes of P_1 , P_2 , P_3 is *dipolar*.

For further information on the equations of conduction, see Professor Stokes *On the Conduction of Heat in Crystals* (Cambridge and Dublin Math. Journ.), and Professor Thomson *on the Dynamical Theory of Heat*, Part V. (*Transactions of Royal Society of Edinburgh*, Vol. XXI. Part I.)

It is evident that all that has been proved in (14), (15), (16), (17), with respect to the superposition of different distributions of pressure, and there being only one distribution of pressures corresponding to a given distribution of sources, will be true also in the case in which the resistance varies from point to point, and the resistance at the same point is different in different directions. For if we examine the proof we shall find it applicable to such cases as well as to that of a uniform medium.

(29) We now are prepared to prove certain general propositions which are true in the most general case of a medium whose resistance is different in different directions and varies from point to point.

We may by the method of (28), when the distribution of pressures is known, construct the surfaces of equal pressure, the tubes of fluid motion, and the sources and sinks. It is evident that since in each cell into which a unit tube is divided by the surfaces of equal pressure unity of fluid passes from pressure p to pressure $(p - 1)$ in unit of time, unity of work is done by the fluid in each cell in overcoming resistance.

The number of cells in each unit tube is determined by the number of surfaces of equal pressure through which it passes. If the pressure at the beginning of the tube be p and at the end p' , then the number of cells in it will be $p - p'$. Now if the tube had extended from the

source to a place where the pressure is zero, the number of cells would have been p , and if the tube had come from the sink to zero, the number would have been p' , and the true number is the difference of these.

Therefore if we find the pressure at a source S from which S tubes proceed to be p , Sp is the number of cells due to the source S ; but if S' of the tubes terminate in a sink at a pressure p' , then we must cut off $S'p'$ cells from the number previously obtained. Now if we denote the source of S tubes by S , the sink of S' tubes may be written $-S'$, sinks always being reckoned negative, and the general expression for the number of cells in the system will be $\Sigma(Sp)$.

(30) The same conclusion may be arrived at by observing that unity of work is done on each cell. Now in each source S , S units of fluid are expelled against a pressure p , so that the work done by the fluid in overcoming resistance is Sp . At each sink in which S' tubes terminate, S' units of fluid sink into nothing under pressure p' ; the work done upon the fluid by the pressure is therefore $S'p'$. The whole work done by the fluid may therefore be expressed by

$$W = \Sigma Sp - \Sigma S'p',$$

or more concisely, considering sinks as negative sources,

$$W = \Sigma(Sp).$$

(31) Let S represent the rate of production of a source in any medium, and let p be the pressure at any given point due to that source. Then if we superpose on this another equal source, every pressure will be doubled, and thus by successive superposition we find that a source nS would produce a pressure np , or more generally the pressure at any point due to a given source varies as the rate of production of the source. This may be expressed by the equation

$$p = RS,$$

where R is a coefficient depending on the nature of the medium and on the positions of the source and the given point. In a uniform medium whose resistance is measured by k ,

$$p = \frac{kS}{4\pi r}, \quad \therefore R = \frac{k}{4\pi r},$$

R may be called the coefficient of resistance of the medium between the source and the given point. By combining any number of sources we have generally

$$p = \Sigma(RS).$$

(32) In a uniform medium the pressure due to a source S

$$p = \frac{k}{4\pi} \frac{S}{r}.$$

At another source S' at a distance r we shall have

$$S'p = \frac{k}{4\pi} \frac{SS'}{r} = Sp',$$

if p' be the pressure at S due to S' . If therefore there be two systems of sources $\Sigma(S)$ and $\Sigma(S')$, and if the pressures due to the first be p and to the second p' , then

$$\Sigma(S'p) = \Sigma(Sp').$$

For every term $S'p$ has a term Sp' equal to it.

(33) Suppose that in a uniform medium the motion of the fluid is everywhere parallel to one plane, then the surfaces of equal pressure will be perpendicular to this plane. If we take two parallel planes at a distance equal to h from each other, we can divide the space between these planes into unit tubes by means of cylindric surfaces perpendicular to the planes, and these together with the surfaces of equal pressure will divide the space into cells of which the length is equal to the breadth. For if h be the distance between consecutive surfaces of equal pressure and s the section of the unit tube, we have by (13) $s = kh$.

But s is the product of the breadth and depth; but the depth is h , therefore the breadth is h and equal to the length.

If two systems of plane curves cut each other at right angles so as to divide the plane into little areas of which the length and breadth are equal, then by taking another plane at distance h from the first and erecting cylindric surfaces on the plane curves as bases, a system of cells will be formed which will satisfy the conditions whether we suppose the fluid to run along the first set of cutting lines or the second*.

Application of the Idea of Lines of Force.

I have now to shew how the idea of lines of fluid motion as described above may be modified so as to be applicable to the sciences of statical electricity, permanent magnetism, magnetism of induction, and uniform galvanic currents, reserving the laws of electro-magnetism for special consideration.

I shall assume that the phenomena of statical electricity have been already explained by the mutual action of two opposite kinds of matter. If we consider one of these as positive electricity and the other as negative, then any two particles of electricity repel one another with a force which is measured by the product of the masses of the particles divided by the square of their distance.

Now we found in (18) that the velocity of our imaginary fluid due to a source S at a distance r varies inversely as r^2 . Let us see what will be the effect of substituting such a source for every particle of positive electricity. The velocity due to each source would be proportional to the attraction due to the corresponding particle, and the resultant velocity due to all the sources would be proportional to the resultant attraction of all the particles. Now we may find the resultant pressure at any point by adding the pressures due to the given sources, and therefore we may find the resultant velocity in a given direction from the rate of decrease of pressure in that direction, and this will be proportional to the resultant attraction of the particles resolved in that direction.

Since the resultant attraction in the electrical problem is proportional to the decrease of pressure in the imaginary problem, and since we may select any values for the constants in the imaginary problem, we may assume that the resultant attraction in any direction is numerically equal to the decrease of pressure in that direction, or

$$X = -\frac{pd}{dv}.$$

* See *Cambridge and Dublin Mathematical Journal*, Vol. III, p. 286.

By this assumption we find that if V be the potential,

$$dV = Xdx + Ydy + Zdz = - dp,$$

or since at an infinite distance $V = 0$ and $p = 0$, $V = -p$.

In the electrical problem we have

$$V = - \sum \left(\frac{dm}{r} \right).$$

In the fluid $p = \sum \left(\frac{k}{4\pi} \frac{S}{r} \right)$;

$$\therefore S = \frac{4\pi}{k} dm.$$

If k be supposed very great, the amount of fluid produced by each source in order to keep up the pressures will be very small.

The potential of any system of electricity on itself will be

$$\sum (pdm) = \frac{k}{4\pi}, \sum (pS) = \frac{k}{4\pi} W.$$

If $\sum (dm)$, $\sum (dm')$ be two systems of electrical particles and pp' the potentials due to them respectively, then by (32)

$$\sum (pdm') = \frac{k}{4\pi}, \sum (pS') = \frac{k}{4\pi}, \sum (p'S) = \sum (p'dm),$$

or the potential of the first system on the second is equal to that of the second system on the first.

So that in the ordinary electrical problems the analogy in fluid motion is of this kind :

$$\begin{aligned} V &= -p, \\ X &= -\frac{dp}{dx} = ku, \\ dm &= \frac{k}{4\pi} S, \end{aligned}$$

whole potential of a system = $-\sum Vdm = \frac{k}{4\pi} W$, where W is the work done by the fluid in overcoming resistance.

The lines of force are the unit tubes of fluid motion, and they may be estimated numerically by those tubes.

Theory of Dielectrics.

The electrical induction exercised on a body at a distance depends not only on the distribution of electricity in the inductric, and the form and position of the inductive body, but on the nature of the interposed medium, or dielectric. Faraday * expresses this by the conception

* Series XI.

of one substance having a *greater inductive capacity*, or conducting the lines of inductive action more freely than another. If we suppose that in our analogy of a fluid in a resisting medium the resistance is different in different media, then by making the resistance less we obtain the analogue to a dielectric which more easily conducts Faraday's lines.

It is evident from (23) that in this case there will always be an apparent distribution of electricity on the surface of the dielectric, there being negative electricity where the lines enter and positive electricity where they emerge. In the case of the fluid there are no real sources on the surface, but we use them merely for purposes of calculation. In the dielectric there may be no real charge of electricity, but only an apparent electric action due to the surface.

If the dielectric had been of less conductivity than the surrounding medium, we should have had precisely opposite effects, namely, positive electricity where lines enter, and negative where they emerge.

If the conduction of the dielectric is perfect or nearly so for the small quantities of electricity with which we have to do, then we have the case of (24). The dielectric is then considered as a conductor, its surface is a surface of equal potential, and the resultant attraction near the surface itself is perpendicular to it.

Theory of Permanent Magnets.

A magnet is conceived to be made up of elementary magnetized particles, each of which has its own north and south poles, the action of which upon other north and south poles is governed by laws mathematically identical with those of electricity. Hence the same application of the idea of lines of force can be made to this subject, and the same analogy of fluid motion can be employed to illustrate it.

But it may be useful to examine the way in which the polarity of the elements of a magnet may be represented by the unit cells in fluid motion. In each unit cell unity of fluid enters by one face and flows out by the opposite face, so that the first face becomes a unit sink and the second a unit source with respect to the rest of the fluid. It may therefore be compared to an elementary magnet, having an equal quantity of north and south magnetic matter distributed over two of its faces. If we now consider the cell as forming part of a system, the fluid flowing out of one cell will flow into the next, and so on, so that the source will be transferred from the end of the cell to the end of the unit tube. If all the unit tubes begin and end on the bounding surface, the sources and sinks will be distributed entirely on that surface, and in the case of a magnet which has what has been called a solenoidal or tubular distribution of magnetism, all the imaginary magnetic matter will be on the surface*.

Theory of Paramagnetic and Diamagnetic Induction.

Faraday† has shewn that the effects of paramagnetic and diamagnetic bodies in the magnetic field may be explained by supposing paramagnetic bodies to conduct the lines of force better,

* See Professor Thomson *On the Mathematical Theory of Magnetism*, Chapters III. & V. *Phil. Trans.* 1851.

† *Experimental Researches* (3292).

and diamagnetic bodies worse, than the surrounding medium. By referring to (23) and (26), and supposing sources to represent north magnetic matter, and sinks south magnetic matter, then if a paramagnetic body be in the neighbourhood of a north pole, the lines of force on entering it will produce south magnetic matter, and on leaving it they will produce an equal amount of north magnetic matter. Since the quantities of magnetic matter on the whole are equal, but the southern matter is nearest to the north pole, the result will be attraction. If on the other hand the body be diamagnetic, or a worse conductor of lines of force than the surrounding medium, there will be an imaginary distribution of northern magnetic matter where the lines pass into the worse conductor, and of southern where they pass out, so that on the whole there will be repulsion.

We may obtain a more general law from the consideration that the potential of the whole system is proportional to the amount of work done by the fluid in overcoming resistance. The introduction of a second medium increases or diminishes the work done according as the resistance is greater or less than that of the first medium. The amount of this increase or diminution will vary as the square of the velocity of the fluid.

Now, by the theory of potentials, the moving force in any direction is measured by the rate of decrease of the potential of the system in passing along that direction, therefore when k' , the resistance within the second medium, is greater than k , the resistance in the surrounding medium, there is a force tending from places where the resultant force v is greater to where it is less, so that a diamagnetic body moves from greater to less values of the resultant force*.

In paramagnetic bodies k' is less than k , so that the force is now from points of less to points of greater resultant magnetic force. Since these results depend only on the relative values of k and k' , it is evident that by changing the surrounding medium, the behaviour of a body may be changed from paramagnetic to diamagnetic at pleasure.

It is evident that we should obtain the same mathematical results if we had supposed that the magnetic force had a power of exciting a polarity in bodies which is in the *same* direction as the lines in paramagnetic bodies, and in the *reverse* direction in diamagnetic bodies †. In fact we have not as yet come to any facts which would lead us to choose any one out of these three theories, that of lines of force, that of imaginary magnetic matter, and that of induced polarity. As the theory of lines of force admits of the most precise, and at the same time least theoretic statement, we shall allow it to stand for the present.

Theory of Magnecrystallic Induction.

The theory of Faraday ‡ with respect to the behaviour of crystals in the magnetic field may be thus stated. In certain crystals and other substances the lines of magnetic force are

* *Experimental Researches* (2797), (2798). See Thomson, *Cambridge and Dublin Mathematical Journal*, May, 1847.

† *Exp. Res.* (2429), (3320). See Weber, Poggendorff, lxxxvii. p. 145. Prof. Tyndall, *Phil. Trans.* 1856, p. 237.

‡ *Exp. Res.* (2836), &c.

conducted with different facility in different directions. The body when suspended in a uniform magnetic field will turn or tend to turn into such a position that the lines of force shall pass through it with least resistance. It is not difficult by means of the principles in (28) to express the laws of this kind of action, and even to reduce them in certain cases to numerical formulæ. The principles of induced polarity and of imaginary magnetic matter are here of little use; but the theory of lines of force is capable of the most perfect adaptation to this class of phenomena.

Theory of the Conduction of Current Electricity.

It is in the calculation of the laws of constant electric currents that the theory of fluid motion which we have laid down admits of the most direct application. In addition to the researches of Ohm on this subject, we have those of M. Kirchhoff, *Ann. de Chim.* xli. 496, and of M. Quincke, xlvii. 203, on the Conduction of Electric Currents in Plates. According to the received opinions we have here a current of fluid moving uniformly in conducting circuits, which oppose a resistance to the current which has to be overcome by the application of an electro-motive force at some part of the circuit. On account of this resistance to the motion of the fluid the pressure must be different at different points in the circuit. This pressure, which is commonly called electrical tension, is found to be physically identical with the *potential* in statical electricity, and thus we have the means of connecting the two sets of phenomena. If we knew what amount of electricity, measured statically, passes along that current which we assume as our unit of current, then the connexion of electricity of tension with current electricity would be completed*. This has as yet been done only approximately, but we know enough to be certain that the conducting powers of different substances differ only in degree, and that the difference between glass and metal is, that the resistance is a great but finite quantity in glass, and a small but finite quantity in metal. Thus the analogy between statical electricity and fluid motion turns out more perfect than we might have supposed, for there the induction goes on by conduction just as in current electricity, but the quantity conducted is insensible owing to the great resistance of the dielectrics †.

On Electro-motive Forces.

When a uniform current exists in a closed circuit it is evident that some other forces must act on the fluid besides the pressures. For if the current were due to difference of pressures, then it would flow from the point of greatest pressure in both directions to the point of least pressure, whereas in reality it circulates in one direction constantly. We

* See *Exp. Res.* (371).

† *Exp. Res.* Vol. III. p. 513.

must therefore admit the existence of certain forces capable of keeping up a constant current in a closed circuit. Of these the most remarkable is that which is produced by chemical action. A cell of a voltaic battery, or rather the surface of separation of the fluid of the cell and the zinc, is the seat of an electro-motive force which can maintain a current in opposition to the resistance of the circuit. If we adopt the usual convention in speaking of electric currents, the positive current is from the fluid through the platinum, the conducting circuit, and the zinc, back to the fluid again. If the electro-motive force act only in the surface of separation of the fluid and zinc, then the tension of electricity in the fluid must exceed that in the zinc by a quantity depending on the nature and length of the circuit and on the strength of the current in the conductor. In order to keep up this difference of pressure there must be an electro-motive force whose intensity is measured by that difference of pressure. If F be the electro-motive force, I the quantity of the current or the number of electrical units delivered in unit of time, and K a quantity depending on the length and resistance of the conducting circuit, then

$$F = IK = p - p',$$

where p is the electric tension in the fluid and p' in the zinc.

If the circuit be broken at any point, then since there is no current the tension of the part which remains attached to the platinum will be p , and that of the other will be p' . $p - p'$, or F affords a measure of the intensity of the current. This distinction of quantity and intensity is very useful*, but must be distinctly understood to mean nothing more than this:—The quantity of a current is the amount of electricity which it transmits in unit of time, and is measured by I the number of unit currents which it contains. The intensity of a current is its power of overcoming resistance, and is measured by F or IK , where K is the resistance of the whole circuit.

The same idea of quantity and intensity may be applied to the case of magnetism†. The quantity of magnetization in any section of a magnetic body is measured by the number of lines of magnetic force which pass through it. The intensity of magnetization in the section depends on the resisting power of the section, as well as on the number of lines which pass through it. If k be the resisting power of the material, and S the area of the section, and I the number of lines of force which pass through it, then the whole intensity throughout the section

$$= F = I \frac{k}{S}.$$

When magnetization is produced by the influence of other magnets only, we may put p for the magnetic tension at any point, then for the whole magnetic solenoid

$$F = I \int \frac{k}{S} dx = IK = p - p'.$$

* *Exp. Res.* Vol. III. p. 519.

† *Exp. Res.* (2870), (3293).

When a solenoidal magnetized circuit returns into itself, the magnetization does not depend on difference of tensions only, but on some magnetizing force of which the intensity is F .

If i be the quantity of the magnetization at any point, or the number of lines of force passing through unit of area in the section of the solenoid, then the total quantity of magnetization in the circuit is the number of lines which pass through any section $I = \sum i dydz$, where $dydz$ is the element of the section, and the summation is performed over the whole section.

The intensity of magnetization at any point, or the force required to keep up the magnetization, is measured by $ki = f$, and the total intensity of magnetization in the circuit is measured by the sum of the local intensities all round the circuit,

$$F = \sum (fdx),$$

where dx is the element of length in the circuit, and the summation is extended round the entire circuit.

In the same circuit we have always $F = IK$, where K is the total resistance of the circuit, and depends on its form and the matter of which it is composed.

On the Action of closed Currents at a Distance.

The mathematical laws of the attractions and repulsions of conductors have been most ably investigated by Ampère, and his results have stood the test of subsequent experiments.

From the single assumption, that the action of an element of one current upon an element of another current is an attractive or repulsive force acting in the direction of the line joining the two elements, he has determined by the simplest experiments the mathematical form of the law of attraction, and has put this law into several most elegant and useful forms. We must recollect however that no experiments have been made on these elements of currents except under the form of closed currents either in rigid conductors or in fluids, and that the laws of closed currents only can be deduced from such experiments. Hence if Ampère's formulæ applied to closed currents give true results, their truth is not proved for *elements* of currents unless we assume that the action between two such elements must be along the line which joins them. Although this assumption is most warrantable and philosophical in the present state of science, it will be more conducive to freedom of investigation if we endeavour to do without it, and to assume the laws of closed currents as the ultimate datum of experiment.

Ampère has shewn that when currents are combined according to the law of the parallelogram of forces, the force due to the resultant current is the resultant of the forces due to the component currents, and that equal and opposite currents generate equal and opposite forces, and when combined neutralize each other.

He has also shewn that a closed circuit of any form has no tendency to turn a moveable circular conductor about a fixed axis through the centre of the circle perpendicular to its plane, and that therefore the forces in the case of a closed circuit render $Xdx + Ydy + Zdz$ a complete differential.

Finally, he has shewn that if there be two systems of circuits similar and similarly situated, the quantity of electrical current in corresponding conductors being the same, the resultant forces are equal, whatever be the absolute dimensions of the systems, which proves that the forces are, *cæteris paribus*, inversely as the square of the distance.

From these results it follows that the mutual action of two closed currents whose areas are very small is the same as that of two elementary magnetic bars magnetized perpendicularly to the plane of the currents.

The direction of magnetization of the equivalent magnet may be predicted by remembering that a current travelling round the earth from east to west as the sun appears to do, would be equivalent to that magnetization which the earth actually possesses, and therefore in the reverse direction to that of a magnetic needle when pointing freely.

If a number of closed unit currents in contact exist on a surface, then at all points in which two currents are in contact there will be two equal and opposite currents which will produce no effect, but all round the boundary of the surface occupied by the currents there will be a residual current not neutralized by any other; and therefore the result will be the same as that of a single unit current round the boundary of all the currents.

From this it appears that the external attractions of a shell uniformly magnetized perpendicular to its surface are the same as those due to a current round its edge, for each of the elementary currents in the former case has the same effect as an element of the magnetic shell.

If we examine the lines of magnetic force produced by a closed current, we shall find that they form closed curves passing round the current and *embracing* it, and that the total intensity of the magnetizing force all along the closed line of force depends on the quantity of the electric current only. The number of unit lines* of magnetic force due to a closed current depends on the form as well as the quantity of the current, but the number of unit cells† in each complete line of force is measured simply by the number of unit currents which embrace it. The unit cells in this case are portions of space in which unit of magnetic quantity is produced by unity of magnetizing force. The length of a cell is therefore inversely as the intensity of the magnetizing force, and its section is inversely as the quantity of magnetic induction at that point.

The whole number of cells due to a given current is therefore proportional to the strength of the current multiplied by the number of lines of force which pass through it. If by any change of the form of the conductors the number of cells can be increased, there will be a force tending to produce that change, so that there is always a force urging a conductor transverse to the lines of magnetic force, so as to cause more lines of force to pass through the closed circuit of which the conductor forms a part.

The number of cells due to two given currents is got by multiplying the number of lines of inductive magnetic action which pass through each by the quantity of the currents respectively. Now by (9) the number of lines which pass through the first current is the sum of its own lines and those of the second current which would pass through the first if the

* *Exp. Res.* (3122). See Art. (6) of this paper.

† Art. (13).

second current alone were in action. Hence the whole number of cells will be increased by any motion which causes more lines of force to pass through either circuit, and therefore the resultant force will tend to produce such a motion, and the work done by this force during the motion will be measured by the number of new cells produced. All the actions of closed conductors on each other may be deduced from this principle.

On Electric Currents produced by Induction.

Faraday has shewn * that when a conductor moves transversely to the lines of magnetic force, an electro-motive force arises in the conductor, tending to produce a current in it. If the conductor is closed, there is a continuous current, if open, tension is the result. If a closed conductor move transversely to the lines of magnetic induction, then, if the number of lines which pass through it does not change during the motion, the electro-motive forces in the circuit will be in equilibrium, and there will be no current. Hence the electro-motive forces depend on the number of lines which are cut by the conductor during the motion. If the motion be such that a greater number of lines pass through the circuit formed by the conductor after than before the motion, then the electro-motive force will be measured by the increase of the number of lines, and will generate a current the reverse of that which would have produced the additional lines. When the number of lines of inductive magnetic action through the circuit is increased, the induced current will tend to diminish the number of the lines, and when the number is diminished the induced current will tend to increase them.

That this is the true expression for the law of induced currents is shewn from the fact that, in whatever way the number of lines of magnetic induction passing through the circuit be increased, the electro-motive effect is the same, whether the increase take place by the motion of the conductor itself, or of other conductors, or of magnets, or by the change of intensity of other currents, or by the magnetization or demagnetization of neighbouring magnetic bodies, or lastly by the change of intensity of the current itself.

In all these cases the electro-motive force depends on the *change* in the number of lines of inductive magnetic action which pass through the circuit †.

* *Exp. Res.* (3077), &c.

† The electro-magnetic forces, which tend to produce motion of the material conductor, must be carefully distinguished from the electro-motive forces, which tend to produce electric currents.

Let an electric current be passed through a mass of metal of any form. The distribution of the currents within the metal will be determined by the laws of conduction. Now let a constant electric current be passed through another conductor near the first. If the two currents are in the same direction the two conductors will be attracted towards each other, and would come nearer if not held in their positions. But though the material conductors are attracted, the currents (which are free to choose any course within the metal) will not alter their original distribution, or incline towards each other. For, since no change takes place in the system, there will be no electro-motive forces to modify the original distribution of currents.

In this case we have electro-magnetic forces acting on the material conductor, without any electro-motive forces tending to modify the current which it carries.

Let us take as another example the case of a linear conductor, not forming a closed circuit, and let it be made to traverse the lines of magnetic force, either by its own motion, or by changes in the magnetic field. An electro-motive force will act in the direction of the conductor, and, as it cannot produce a current, because there is no circuit, it will produce electric tension at the extremities. There will be no electro-magnetic attraction on the material conductor, for this attraction depends on the existence of the current within it, and this is prevented by the circuit not being closed.

Here then we have the opposite case of an electro-motive force acting on the electricity in the conductor, but no attraction on its material particles.

It is natural to suppose that a force of this kind, which depends on a change in the number of lines, is due to a change of state which is measured by the number of these lines. A closed conductor in a magnetic field may be supposed to be in a certain state arising from the magnetic action. As long as this state remains unchanged no effect takes place, but, when the state changes, electro-motive forces arise, depending as to their intensity and direction on this change of state. I cannot do better here than quote a passage from the first series of Faraday's *Experimental Researches*, Art. (60).

“While the wire is subject to either volta-electric or magneto-electric induction it appears to be in a peculiar state, for it resists the formation of an electrical current in it; whereas, if in its common condition, such a current would be produced; and when left uninfluenced it has the power of originating a current, a power which the wire does not possess under ordinary circumstances. This electrical condition of matter has not hitherto been recognised, but it probably exerts a very important influence in many if not most of the phenomena produced by currents of electricity. For reasons which will immediately appear (71) I have, after advising with several learned friends, ventured to designate it as the *electro-tonic* state.” Finding that all the phenomena could be otherwise explained without reference to the electro-tonic state, Faraday in his second series rejected it as not necessary; but in his recent researches* he seems still to think that there may be some physical truth in his conjecture about this new state of bodies.

The conjecture of a philosopher so familiar with nature may sometimes be more pregnant with truth than the best established experimental law discovered by empirical inquirers, and though not bound to admit it as a physical truth, we may accept it as a new idea by which our mathematical conceptions may be rendered clearer.

In this outline of Faraday's electrical theories, as they appear from a mathematical point of view, I can do no more than simply state the mathematical methods by which I believe that electrical phenomena can be best comprehended and reduced to calculation, and my aim has been to present the mathematical ideas to the mind in an embodied form, as systems of lines or surfaces, and not as mere symbols, which neither convey the same ideas, nor readily adapt themselves to the phenomena to be explained. The idea of the electro-tonic state, however, has not yet presented itself to my mind in such a form that its nature and properties may be clearly explained without reference to mere symbols, and therefore I propose in the following investigation to use symbols freely, and to take for granted the ordinary mathematical operations. By a careful study of the laws of elastic solids and of the motions of viscous fluids, I hope to discover a method of forming a mechanical conception of this electro-tonic state adapted to general reasoning †.

PART II. *On Faraday's "Electro-tonic State."*

When a conductor moves in the neighbourhood of a current of electricity, or of a magnet, or when a current or magnet near the conductor is moved, or altered in intensity, then a force

* (3172) (3269).

† See Prof. W. Thomson *On a Mechanical Representation of Electric, Magnetic and Galvanic Forces.* Camb. and Dub. Math. Jour. Jan. 1847.

acts on the conductor and produces electric tension, or a continuous current, according as the circuit is open or closed. This current is produced only by *changes* of the electric or magnetic phenomena surrounding the conductor, and as long as these are constant there is no observed effect on the conductor. Still the conductor is in different states when near a current or magnet, and when away from its influence, since the removal or destruction of the current or magnet occasions a current, which would not have existed if the magnet or current had not been previously in action.

Considerations of this kind led Professor Faraday to connect with his discovery of the induction of electric currents, the conception of a state into which all bodies are thrown by the presence of magnets and currents. This state does not manifest itself by any known phenomena as long as it is undisturbed, but any change in this state is indicated by a current or tendency towards a current. To this state he gave the name of the "Electro-tonic State," and although he afterwards succeeded in explaining the phenomena which suggested it by means of less hypothetical conceptions, he has on several occasions hinted at the probability that some phenomena might be discovered which would render the electro-tonic state an object of legitimate induction. These speculations, into which Faraday had been led by the study of laws which he has well established, and which he abandoned only for want of experimental data for the direct proof of the unknown state, have not, I think, been made the subject of mathematical investigation. Perhaps it may be thought that the quantitative determinations of the various phenomena are not sufficiently rigorous to be made the basis of a mathematical theory; Faraday, however, has not contented himself with simply stating the numerical results of his experiments and leaving the law to be discovered by calculation. Where he has perceived a law he has at once stated it, in terms as unambiguous as those of pure mathematics; and if the mathematician, receiving this as a physical truth, deduces from it other laws capable of being tested by experiment, he has merely assisted the physicist in arranging his own ideas, which is confessedly a necessary step in scientific induction.

In the following investigation, therefore, the laws established by Faraday will be assumed as true, and it will be shewn that by following out his speculations other and more general laws can be deduced from them. If it should then appear that these laws, originally devised to include one set of phenomena, may be generalized so as to extend to phenomena of a different class, these mathematical connexions may suggest to physicists the means of establishing physical connexions; and thus mere speculation may be turned to account in experimental science.

On Quantity and Intensity as Properties of Electric Currents.

It is found that certain effects of an electric current are equal at whatever part of the circuit they are estimated. The quantities of water or of any other electrolyte decomposed at two different sections of the same circuit, are always found to be equal or equivalent, however different the material and form of the circuit may be at the two sections. The magnetic effect of a conducting wire is also found to be independent of the form or material of the wire

in the same circuit. There is therefore an electrical effect which is equal at every section of the circuit. If we conceive of the conductor as the channel along which a fluid is constrained to move, then the quantity of fluid transmitted by each section will be the same, and we may define the *quantity* of an electric current to be the quantity of electricity which passes across a complete section of the current in unit of time. We may for the present measure quantity of electricity by the quantity of water which it would decompose in unit of time.

In order to express mathematically the electrical currents in any conductor, we must have a definition, not only of the entire flow across a complete section, but also of the flow at a given point in a given direction.

DEF. The quantity of a current at a given point and in a given direction is measured, when uniform, by the quantity of electricity which flows across unit of area taken at that point perpendicular to the given direction, and when variable by the quantity which would flow across this area, supposing the flow uniformly the same as at the given point.

In the following investigation, the quantity of electric current at the point (xyz) estimated in the directions of the axes x , y , z respectively will be denoted by a_2 b_2 c_2 .

The quantity of electricity which flows in unit of time through the elementary area dS

$$= dS (la_2 + mb_2 + nc_2),$$

where lmn are the direction-cosines of the normal to dS .

This flow of electricity at any point of a conductor is due to the electro-motive forces which act at that point. These may be either external or internal.

External electro-motive forces arise either from the relative motion of currents and magnets, or from changes in their intensity, or from other causes acting at a distance.

Internal electro-motive forces arise principally from difference of electric tension at points of the conductor in the immediate neighbourhood of the point in question. The other causes are variations of caemical composition or of temperature in contiguous parts of the conductor.

Let p_2 represent the electric tension at any point, and X_2 Y_2 Z_2 the sums of the parts of all the electro-motive forces arising from other causes resolved parallel to the co-ordinate axes, then if a_2 β_2 γ_2 be the effective electro-motive forces

$$\left. \begin{aligned} a_2 &= X_2 - \frac{dp_2}{dx} \\ \beta_2 &= Y_2 - \frac{dp_2}{dy} \\ \gamma_2 &= Z_2 - \frac{dp_2}{dz} \end{aligned} \right\} \quad (\text{A})$$

Now the quantity of the current depends on the electro-motive force and on the resistance of the medium. If the resistance of the medium be uniform in all directions and equal to k_2 ,

$$a_2 = k_2 a_{21}, \quad \beta_2 = k_2 b_{21}, \quad \gamma_2 = k_2 c_{21}, \quad (\text{B})$$

but if the resistance be different in different directions, the law will be more complicated.

These quantities a_2 β_2 γ_2 may be considered as representing the intensity of the electric action in the directions of xyz .

The intensity measured along an element $d\sigma$ of a curve

$$\epsilon = l\alpha + m\beta + n\gamma,$$

where lmn are the direction-cosines of the tangent.

The integral $\int \epsilon d\sigma$ taken with respect to a given portion of a curve line, represents the total intensity along that line. If the curve is a closed one, it represents the total intensity of the electro-motive force in the closed curve.

Substituting the values of $\alpha\beta\gamma$ from equations (A)

$$\int \epsilon d\sigma = \int (Xd\alpha + Yd\beta + Zd\gamma) - p + C.$$

If, therefore $(Xd\alpha + Yd\beta + Zd\gamma)$ is a complete differential, the value of $\int \epsilon d\sigma$ for a closed curve will vanish, and in all closed curves

$$\int \epsilon d\sigma = \int (Xd\alpha + Yd\beta + Zd\gamma),$$

the integration being effected along the curve, so that in a closed curve the total intensity of the effective electro-motive force is equal to the total intensity of the impressed electro-motive force.

The total *quantity* of conduction through any surface is expressed by

$$\int \epsilon dS,$$

where

$$e = la + mb + nc,$$

lmn being the direction-cosines of the normal,

$$\therefore \int \epsilon dS = \iint a dy dz + \iint b dz dx + \iint c dx dy,$$

the integrations being effected over the given surface. When the surface is a closed one, then we may find by integration by parts

$$\int \epsilon dS = \iiint \left(\frac{da}{dx} + \frac{db}{dy} + \frac{dc}{dz} \right) dx dy dz.$$

If we make

$$\frac{da}{dx} + \frac{db}{dy} + \frac{dc}{dz} = 4\pi\rho \dots \dots \dots (C)$$

$$\int \epsilon dS = 4\pi \iiint \rho dx dy dz,$$

where the integration on the right side of the equation is effected over every part of space within the surface. In a large class of phenomena, including all cases of uniform currents, the quantity ρ disappears.

Magnetic Quantity and Intensity.

From his study of the lines of magnetic force, Faraday has been led to the conclusion that in the tubular surface* formed by a system of such lines, the quantity of magnetic induction across any section of the tube is constant, and that the alteration of the character of these lines in passing from one substance to another, is to be explained by a difference of *inductive capacity* in the two substances, which is analogous to conductive power in the theory of electric currents.

* *Exp. Res.* 3271, definition of "Sphondyloid."

In the following investigation we shall have occasion to treat of magnetic quantity and intensity in connexion with electric. In such cases the magnetic symbols will be distinguished by the suffix 1, and the electric by the suffix 2. The equations connecting a , b , c , k , α , β , γ , p , and ρ , are the same in form as those which we have just given. a , b , c are the symbols of magnetic induction with respect to quantity; k , denotes the resistance to magnetic induction, and may be different in different directions; α , β , γ , are the effective magnetizing forces, connected with a , b , c , by equations (B); p , is the magnetic tension or potential which will be afterwards explained; ρ denotes the density of *real magnetic matter* and is connected with a , b , c by equations (C). As all the details of magnetic calculations will be more intelligible after the exposition of the connexion of magnetism with electricity, it will be sufficient here to say that all the definitions of total quantity, with respect to a surface, and total intensity with respect to a curve, apply to the case of magnetism as well as to that of electricity.

Electro-magnetism.

Ampère has proved the following laws of the attractions and repulsions of electric currents :

I. Equal and opposite currents generate equal and opposite forces.

II. A crooked current is equivalent to a straight one, provided the two currents nearly coincide throughout their whole length.

III. Equal currents traversing similar and similarly situated closed curves act with equal forces, whatever be the linear dimensions of the circuits.

IV. A closed current exerts no force tending to turn a circular conductor about its centre.

It is to be observed, that the currents with which Ampère worked were constant and therefore re-entering. All his results are therefore deduced from experiments on closed currents, and his expressions for the mutual action of the elements of a current involve the assumption that this action is exerted in the direction of the line joining those elements. This assumption is no doubt warranted by the universal consent of men of science in treating of attractive forces considered as due to the mutual action of particles; but at present we are proceeding on a different principle, and searching for the explanation of the phenomena, not in the currents alone, but also in the surrounding medium.

The first and second laws shew that currents are to be combined like velocities or forces.

The third law is the expression of a property of all attractions which may be conceived of as depending on the inverse square of the distance from a fixed system of points; and the fourth shews that the electro-magnetic forces may always be reduced to the attractions and repulsions of imaginary matter properly distributed.

In fact, the action of a very small electric circuit on a point in its neighbourhood is identical with that of a small magnetic element on a point outside it. If we divide any given portion of a surface into elementary areas, and cause equal currents to flow in the same direction round all these little areas, the effect on a point not in the surface will be the

same as that of a shell coinciding with the surface, and uniformly magnetized normal to its surface. But by the first law all the currents forming the little circuits will destroy one another, and leave a single current running round the bounding line. So that the magnetic effect of a uniformly magnetized shell is equivalent to that of an electric current round the edge of the shell. If the direction of the current coincide with that of the apparent motion of the sun, then the direction of magnetization of the imaginary shell will be the same as that of the real magnetization of the earth*.

The total intensity of magnetizing force in a closed curve passing through and embracing the closed current is constant, and may therefore be made a measure of the quantity of the current. As this intensity is independent of the form of the closed curve and depends only on the quantity of the current which passes through it, we may consider the elementary case of the current which flows through the elementary area $dydz$.

Let the axis of x point towards the west, z towards the south, and y upwards. Let xyz be the position of a point in the middle of the area $dydz$, then the total intensity measured round the four sides of the element is

$$\begin{aligned}
 &+ \left(B_1 + \frac{d\beta_1}{dx} \frac{dz}{2} \right) dy, \\
 &- \left(\gamma_1 + \frac{d\gamma_1}{dy} \frac{dy}{2} \right) dz, \\
 &- \left(\beta_1 - \frac{d\beta_1}{dz} \frac{dz}{2} \right) dy, \\
 &+ \left(\gamma_1 - \frac{d\gamma_1}{dy} \frac{dy}{2} \right) dz, \\
 \text{Total intensity} &= \left(\frac{d\beta_1}{dx} - \frac{d\gamma_1}{dy} \right) dy dz.
 \end{aligned}$$

The quantity of electricity conducted through the elementary area $dydz$ is $a_2 dydz$, and therefore if we define the measure of an electric current to be the total intensity of magnetizing force in a closed curve embracing it, we shall have

$$\begin{aligned}
 a_2 &= \frac{d\beta_1}{dx} - \frac{d\gamma_1}{dy}, \\
 b_2 &= \frac{d\gamma_1}{dx} - \frac{da_1}{dx}, \\
 c_2 &= \frac{da_1}{dy} - \frac{d\beta_1}{dx}.
 \end{aligned}$$

These equations enable us to deduce the distribution of the currents of electricity whenever we know the values of a , β , γ , the magnetic intensities. If a , β , γ be exact differentials of a function of xyz with respect to x , y and z respectively, then the values of a_2 , b_2 , c_2 disappear ;

* See *Experimental Researches* (3265) for the relations between the electrical and magnetic circuit, considered as *mutually embracing curves*.

and we know that the magnetism is not produced by electric currents in that part of the field which we are investigating. It is due either to the presence of permanent magnetism within the field, or to magnetizing forces due to external causes.

We may observe that the above equations give by differentiation

$$\frac{da_2}{dx} + \frac{db_2}{dy} + \frac{dc_2}{dz} = 0,$$

which is the equation of continuity for closed currents. Our investigations are therefore for the present limited to closed currents; and in fact we know little of the magnetic effects of any currents which are not closed.

Before entering on the calculation of these electric and magnetic states it may be advantageous to state certain general theorems, the truth of which may be established analytically.

THEOREM I.

The equation

$$\frac{d^2 V}{dx^2} + \frac{d^2 V}{dy^2} + \frac{d^2 V}{dz^2} + 4\pi\rho = 0,$$

(where V and ρ are functions of xyz never infinite, and vanishing for all points at an infinite distance,) can be satisfied by one, and only one, value of V . See Art. (17) above.

THEOREM II.

The value of V which will satisfy the above conditions is found by integrating the expression

$$\iiint \frac{\rho dx dy dz}{(x-x')^2 + (y-y')^2 + (z-z')^2)^{\frac{1}{2}}},$$

where the limits of xyz are such as to include every point of space where ρ is finite.

The proofs of these theorems may be found in any work on attractions or electricity, and in particular in Green's *Essay on the Application of Mathematics to Electricity*. See Arts. 18, 19 of this Paper. See also Gauss, *on Attractions*, translated in Taylor's *Scientific Memoirs*.

THEOREM III.

Let U and V be two functions of xyz , then

$$\begin{aligned} \iiint U \left(\frac{d^2 V}{dx^2} + \frac{d^2 V}{dy^2} + \frac{d^2 V}{dz^2} \right) dx dy dz &= - \iiint \left(\frac{dU}{dx} \frac{dV}{dx} + \frac{dU}{dy} \frac{dV}{dy} + \frac{dU}{dz} \frac{dV}{dz} \right) dx dy dz \\ &= \iiint \left(\frac{d^2 U}{dx^2} + \frac{d^2 U}{dy^2} + \frac{d^2 U}{dz^2} \right) V dx dy dz; \end{aligned}$$

where the integrations are supposed to extend over all the space in which U and V have values differing from 0.—(Green, p. 10.)

This theorem shews that if there be two attracting systems the actions between them are equal and opposite. And by making $U = V$ we find that the potential of a system on itself is proportional to the integral of the square of the resultant attraction through all space; a

result deducible from Art. (30), since the volume of each cell is inversely as the square of the velocity (Arts. 12, 13), and therefore the number of cells in a given space is directly as the square of the velocity.

THEOREM IV.

Let $\alpha, \beta, \gamma, \rho$ be quantities finite through a certain space and vanishing in the space beyond, and let k be given for all parts of space as a continuous or discontinuous function of xyz , then the equation in p

$$\frac{d}{dx} \frac{1}{k} \left(\alpha - \frac{dp}{dx} \right) + \frac{d}{dy} \frac{1}{k} \left(\beta - \frac{dp}{dy} \right) + \frac{d}{dz} \frac{1}{k} \left(\gamma - \frac{dp}{dz} \right) + 4\pi\rho = 0,$$

has one, and only one solution, in which p is always finite and vanishes at an infinite distance.

The proof of this theorem, by Prof. W. Thomson, may be found in the *Cambridge and Dublin Math. Journal*, Jan. 1848.

If $\alpha\beta\gamma$ be the electro-motive forces, p the electric tension, and k the coefficient of resistance, then the above equation is identical with the equation of continuity

$$\frac{da_x}{dx} + \frac{db_y}{dy} + \frac{dc_z}{dz} + 4\pi\rho = 0;$$

and the theorem shews that when the electro-motive forces and the rate of production of electricity at every part of space are given, the value of the electric tension is determinate.

Since the mathematical laws of magnetism are identical with those of electricity, as far as we now consider them, we may regard $\alpha\beta\gamma$ as magnetizing forces, p as *magnetic tension*, and ρ as *real magnetic density*, k being the coefficient of resistance to magnetic induction.

The proof of this theorem rests on the determination of the minimum value of

$$Q = \iiint \left\{ k \left(\alpha - \frac{dp}{dx} - k \frac{dV}{dx} \right)^2 + \frac{1}{k} \left(\beta - \frac{dp}{dy} - k \frac{dV}{dy} \right)^2 + \frac{1}{k} \left(\gamma - \frac{dp}{dz} - k \frac{dV}{dz} \right)^2 \right\} dx dy dz;$$

where V is got from the equation

$$\frac{d^2 V}{dx^2} + \frac{d^2 V}{dy^2} + \frac{d^2 V}{dz^2} + 4\pi\rho = 0,$$

and p has to be determined.

The meaning of this integral in electrical language may be thus brought out. If the presence of the media in which k has various values did not affect the distribution of forces, then the "quantity" resolved in x would be simply $\frac{dV}{dx}$ and the intensity $k \frac{dV}{dx}$. But the actual quantity and intensity are $\frac{1}{k} \left(\alpha - \frac{dp}{dx} \right)$ and $\alpha - \frac{dp}{dx}$, and the parts due to the distribution of media alone are therefore

$$\frac{1}{k} \left(\alpha - \frac{dp}{dx} \right) - \frac{dV}{dx} \text{ and } \alpha - \frac{dp}{dx} - k \frac{dV}{dx}.$$

Now the product of these represents the work done on account of this distribution of media, the distribution of sources being determined, and taking in the terms in y and z we get the expression Q for the total work done by that part of the whole effect at any point which is due to the distribution of conducting media, and not directly to the presence of the sources.

This quantity Q is rendered a minimum by one and only one value of p , namely, that which satisfies the original equation.

THEOREM V.

If a, b, c be three functions of x, y, z satisfying the equation

$$\frac{da}{dx} + \frac{db}{dy} + \frac{dc}{dz} = 0,$$

it is always possible to find three functions α, β, γ which shall satisfy the equations

$$\frac{d\beta}{dz} - \frac{d\gamma}{dy} = a,$$

$$\frac{d\gamma}{dx} - \frac{da}{dz} = b,$$

$$\frac{da}{dy} - \frac{d\beta}{dx} = c.$$

Let $A = \int c dy$, where the integration is to be performed upon c considered as a function of y , treating x and z as constants. Let $B = \int a dz$, $C = \int b dx$, $A' = \int b dz$, $B' = \int c dx$, $C' = \int a dy$, integrated in the same way.

Then

$$a = A - A' + \frac{d\psi}{dx},$$

$$\beta = B - B' + \frac{d\psi}{dy},$$

$$\gamma = C - C' + \frac{d\psi}{dz}$$

will satisfy the given equations; for

$$\frac{d\beta}{dz} - \frac{d\gamma}{dy} = \int \frac{da}{dy} dz - \int \frac{dc}{dz} dx - \int \frac{db}{dy} dx + \int \frac{da}{dy} dy,$$

and

$$0 = \int \frac{da}{dx} dx + \int \frac{db}{dy} dx + \int \frac{dc}{dz} dx;$$

$$\begin{aligned} \therefore \frac{d\beta}{dz} - \frac{d\gamma}{dy} &= \int \frac{da}{dx} dx + \int \frac{da}{dy} dy + \int \frac{da}{dz} dz \\ &= a. \end{aligned}$$

In the same way it may be shewn that the values of α , β , γ satisfy the other given equations. The function ψ may be considered at present as perfectly indeterminate.

The method here given is taken from Prof. W. Thomson's memoir on Magnetism (*Phil. Trans.* 1851, p. 283).

As we cannot perform the required integrations when a , b , c are discontinuous functions of x , y , z , the following method, which is perfectly general though more complicated, may indicate more clearly the truth of the proposition.

Let A , B , C be determined from the equations

$$\begin{aligned}\frac{d^2 A}{dx^2} + \frac{d^2 A}{dy^2} + \frac{d^2 A}{dz^2} + a &= 0, \\ \frac{d^2 B}{dx^2} + \frac{d^2 B}{dy^2} + \frac{d^2 B}{dz^2} + b &= 0, \\ \frac{d^2 C}{dx^2} + \frac{d^2 C}{dy^2} + \frac{d^2 C}{dz^2} + c &= 0,\end{aligned}$$

by the methods of Theorems I. and II., so that A , B , C are never infinite, and vanish when x , y , or z is infinite.

Also let

$$\begin{aligned}\alpha &= \frac{dB}{dz} - \frac{dC}{dy} + \frac{d\psi}{dx}, \\ \beta &= \frac{dC}{dx} - \frac{dA}{dz} + \frac{d\psi}{dy}, \\ \gamma &= \frac{dA}{dy} - \frac{dB}{dx} + \frac{d\psi}{dz},\end{aligned}$$

then

$$\begin{aligned}\frac{d\beta}{dz} - \frac{d\gamma}{dy} &= \frac{d}{dx} \left(\frac{dA}{dx} + \frac{dB}{dy} + \frac{dC}{dz} \right) - \left(\frac{d^2 A}{dx^2} + \frac{d^2 A}{dy^2} + \frac{d^2 A}{dz^2} \right) \\ &= \frac{d}{dx} \left(\frac{dA}{dx} + \frac{dB}{dy} + \frac{dC}{dz} \right) + a.\end{aligned}$$

If we find similar equations in y and z , and differentiate the first by x , the second by y , and the third by z , remembering the equation between a , b , c , we shall have

$$\left(\frac{d^2}{dx^2} + \frac{d^2}{dy^2} + \frac{d^2}{dz^2} \right) \left(\frac{dA}{dx} + \frac{dB}{dy} + \frac{dC}{dz} \right) = 0;$$

and since A , B , C are always finite and vanish at an infinite distance, the only solution of this equation is

$$\frac{dA}{dx} + \frac{dB}{dy} + \frac{dC}{dz} = 0,$$

and we have finally

$$\frac{d\beta}{dz} - \frac{d\gamma}{dy} = a,$$

with two similar equations, shewing that α , β , γ have been rightly determined.

The function ψ is to be determined from the condition

$$\frac{da}{dx} + \frac{d\beta}{dy} + \frac{d\gamma}{dz} = \left(\frac{d^2}{dx^2} + \frac{d^2}{dy^2} + \frac{d^2}{dz^2} \right) \psi;$$

if the left-hand side of this equation be always zero, ψ must be zero also.

THEOREM VI.

Let a, b, c be any three functions of x, y, z , it is possible to find three functions α, β, γ and a fourth V , so that

$$\frac{d\alpha}{dx} + \frac{d\beta}{dy} + \frac{d\gamma}{dz} = 0,$$

and

$$a = \frac{d\beta}{dz} - \frac{d\gamma}{dy} + \frac{dV}{dx},$$

$$b = \frac{d\gamma}{dx} - \frac{da}{dz} + \frac{dV}{dy},$$

$$c = \frac{da}{dy} - \frac{d\beta}{dx} + \frac{dV}{dz}.$$

Let

$$\frac{da}{dx} + \frac{db}{dy} + \frac{dc}{dz} = -4\pi\rho,$$

and let V be found from the equation

$$\frac{d^2V}{dx^2} + \frac{d^2V}{dy^2} + \frac{d^2V}{dz^2} = -4\pi\rho,$$

then

$$a' = a - \frac{dV}{dx},$$

$$b' = b - \frac{dV}{dy},$$

$$c' = c - \frac{dV}{dz},$$

satisfy the condition

$$\frac{da'}{dx} + \frac{db'}{dy} + \frac{dc'}{dz} = 0;$$

and therefore we can find three functions A, B, C , and from these a, β, γ , so as to satisfy the given equations.

THEOREM VII.

The integral throughout infinity

$$Q = \iiint (a_1\alpha_1 + b_1\beta_1 + c_1\gamma_1) dx dy dz,$$

where $a_1 b_1 c_1$, $a_1 \beta_1 \gamma_1$ are any functions whatsoever, is capable of transformation into

$$Q = + \iiint \{4\pi p \rho_1 - (a_0 a_2 + \beta_0 b_2 + \gamma_0 c_2)\} dx dy dz,$$

in which the quantities are found from the equations

$$\frac{da_1}{dx} + \frac{db_1}{dy} + \frac{dc_1}{dz} + 4\pi \rho_1 = 0,$$

$$\frac{d\alpha_1}{dx} + \frac{d\beta_1}{dy} + \frac{d\gamma_1}{dz} + 4\pi \rho_1' = 0;$$

$a_0 \beta_0 \gamma_0 V$ are determined from $a_1 b_1 c_1$ by the last theorem, so that

$$a_1 = \frac{d\beta_0}{dz} - \frac{d\gamma_0}{dy} + \frac{dV}{dx};$$

$a_2 b_2 c_2$ are found from $a_1 \beta_1 \gamma_1$ by the equations

$$a_2 = \frac{d\beta_1}{dz} - \frac{d\gamma_1}{dy} \text{ \&c.},$$

and p is found from the equation

$$\frac{d^2 p}{dx^2} + \frac{d^2 p}{dy^2} + \frac{d^2 p}{dz^2} + 4\pi \rho_1' = 0.$$

For, if we put a_1 in the form

$$\frac{d\beta_0}{dz} - \frac{d\gamma_0}{dy} + \frac{dV}{dx},$$

and treat b_1 and c_1 similarly, then we have by integration by parts through infinity, remembering that all the functions vanish at the limits,

$$Q = - \iiint \left\{ V \left(\frac{da_1}{dx} + \frac{d\beta_1}{dy} + \frac{d\gamma_1}{dz} \right) + a_0 \left(\frac{d\beta_1}{dz} - \frac{d\gamma_1}{dy} \right) + \beta_0 \left(\frac{d\gamma_1}{dx} - \frac{da_1}{dz} \right) + \gamma_0 \left(\frac{da_1}{dy} - \frac{d\beta_1}{dx} \right) \right\} dx dy dz,$$

$$\text{or } Q = + \iiint \{4\pi V \rho_1' - (a_0 a_2 + \beta_0 b_2 + \gamma_0 c_2)\} dx dy dz,$$

and by Theorem III.

$$\iiint V \rho_1' dx dy dz = \iiint p \rho dx dy dz,$$

so that finally

$$Q = \iiint \{4\pi p \rho - (a_0 a_2 + \beta_0 b_2 + \gamma_0 c_2)\} dx dy dz.$$

If $a_1 b_1 c_1$ represent the components of magnetic quantity, and $a_1 \beta_1 \gamma_1$ those of magnetic intensity, then ρ will represent the *real magnetic density*, and p the magnetic potential or tension. $a_2 b_2 c_2$ will be the components of quantity of electric currents, and $a_0 \beta_0 \gamma_0$ will be three functions deduced from $a_1 b_1 c_1$, which will be found to be the mathematical expression for Faraday's Electro-tonic state.

Let us now consider the bearing of these analytical theorems on the theory of magnetism. Whenever we deal with quantities relating to magnetism, we shall distinguish them by the suffix (1). Thus $a_1 b_1 c_1$ are the components resolved in the directions of x , y , z of the

quantity of magnetic induction acting through a given point, and $\alpha_1, \beta_1, \gamma_1$ are the resolved intensities of magnetization at the same point, or, what is the same thing, the components of the force which would be exerted on a unit south pole of a magnet placed at that point without disturbing the distribution of magnetism.

The electric currents are found from the magnetic intensities by the equations

$$a_2 = \frac{d\beta_1}{dz} - \frac{d\gamma_1}{dy} \text{ \&c.}$$

When there are no electric currents, then

$$\alpha_1 dx + \beta_1 dy + \gamma_1 dz = dp_1,$$

a perfect differential of a function of x, y, z . On the principle of analogy we may call p_1 the magnetic tension.

The forces which act on a mass m of south magnetism at any point are

$$-m \frac{dp_1}{dx}, \quad -m \frac{dp_1}{dy}, \quad \text{and} \quad -m \frac{dp_1}{dz},$$

in the direction of the axes, and therefore the whole work done during any displacement of a magnetic system is equal to the decrement of the integral

$$Q = \iiint \rho_1 p_1 dx dy dz$$

throughout the system.

Let us now call Q the *total potential of the system on itself*. The increase or decrease of Q will measure the work lost or gained by any displacement of any part of the system, and will therefore enable us to determine the forces acting on that part of the system.

By Theorem III. Q may be put under the form

$$Q = + \frac{1}{4\pi} \iiint (a_1 \alpha_1 + b_1 \beta_1 + c_1 \gamma_1) dx dy dz,$$

in which $\alpha_1, \beta_1, \gamma_1$ are the differential coefficients of p_1 with respect to x, y, z respectively.

If we now assume that this expression for Q is true whatever be the values of $\alpha_1, \beta_1, \gamma_1$, we pass from the consideration of the magnetism of permanent magnets to that of the magnetic effects of electric currents, and we have then by Theorem VII.

$$Q = \iiint \left\{ p_1 \rho_1 - \frac{1}{4\pi} (a_0 a_2 + \beta_0 b_2 + \gamma_0 c_2) \right\} dx dy dz.$$

So that in the case of electric currents, the components of the currents have to be multiplied by the functions $\alpha_0, \beta_0, \gamma_0$ respectively, and the summations of all such products throughout the system gives us the part of Q due to those currents.

We have now obtained in the functions $\alpha_0, \beta_0, \gamma_0$ the means of avoiding the consideration of the quantity of magnetic induction which *passes through* the circuit. Instead of this artificial method we have the natural one of considering the current with reference to quantities existing in the same space with the current itself. To these I give the name of *Electro-tonic functions*, or *components of the Electro-tonic intensity*.

Let us now consider the conditions of the conduction of the electric currents within the medium during changes in the electro-tonic state. The method which we shall adopt is an application of that given by Helmholtz in his memoir on the Conservation of Force*.

Let there be some external source of electric currents which would generate in the conducting mass currents whose quantity is measured by $a_2 b_2 c_2$ and their intensity by $a_2 \beta_2 \gamma_2$.

Then the amount of work due to this cause in the time dt is

$$dt \iiint (a_2 a_2 + b_2 \beta_2 + c_2 \gamma_2) dx dy dz$$

in the form of resistance overcome, and

$$\frac{dt}{4\pi} \frac{d}{dt} \iiint (a_2 a_0 + b_2 \beta_0 + c_2 \gamma_0) dx dy dz$$

in the form of work done mechanically by the electro-magnetic action of these currents. If there be no external cause producing currents, then the quantity representing the whole work done by the external cause must vanish, and we have

$$dt \iiint (a_2 a_2 + b_2 \beta_2 + c_2 \gamma_2) dx dy dz + \frac{dt}{4\pi} \frac{d}{dt} \iiint (a_2 a_0 + b_2 \beta_0 + c_2 \gamma_0) dx dy dz,$$

where the integrals are taken through any arbitrary space. We must therefore have

$$a_2 a_2 + b_2 \beta_2 + c_2 \gamma_2 = \frac{1}{4\pi} \frac{d}{dt} (a_2 a_0 + b_2 \beta_0 + c_2 \gamma_0)$$

for every point of space; and it must be remembered that the variation of Q is supposed due to variations of $a_0 \beta_0 \gamma_0$, and not of $a_2 b_2 c_2$. We must therefore treat $a_2 b_2 c_2$ as constants, and the equation becomes

$$a_2 \left(a_2 + \frac{1}{4\pi} \frac{da_0}{dt} \right) + b_2 \left(\beta_2 + \frac{1}{4\pi} \frac{d\beta_0}{dt} \right) + c_2 \left(\gamma_2 + \frac{1}{4\pi} \frac{d\gamma_0}{dt} \right) = 0.$$

In order that this equation may be independent of the values of $a_2 b_2 c_2$, each of these coefficients must = 0; and therefore we have the following expressions for the electro-motive forces due to the action of magnets and currents at a distance in terms of the electro-tonic functions,

$$a_2 = - \frac{1}{4\pi} \frac{da_0}{dt}, \quad \beta_2 = - \frac{1}{4\pi} \frac{d\beta_0}{dt}, \quad \gamma_2 = - \frac{1}{4\pi} \frac{d\gamma_0}{dt}.$$

It appears from experiment that the expression $\frac{da_0}{dt}$ refers to the change of electro-tonic state of a given particle of the conductor, whether due to change in the electro-tonic functions themselves or to the motion of the particle.

If a_0 be expressed as a function of x, y, z , and t , and if x, y, z be the co-ordinates of a moving article, then the electro-motive force measured in the direction of x is

$$a_2 = - \frac{1}{4\pi} \left(\frac{da_0}{dx} \frac{dx}{dt} + \frac{da_0}{dy} \frac{dy}{dt} + \frac{da_0}{dz} \frac{dz}{dt} + \frac{da_0}{dt} \right).$$

* Translated in Taylor's *New Scientific Memoirs*, Part II.

The expressions for the electro-motive forces in y and z are similar. The distribution of currents due to these forces depends on the form and arrangement of the conducting media and on the resultant electric tension at any point.

The discussion of these functions would involve us in mathematical formulæ, of which this paper is already too full. It is only on account of their physical importance as the mathematical expression of one of Faraday's conjectures that I have been induced to exhibit them at all in their present form. By a more patient consideration of their relations, and with the help of those who are engaged in physical inquiries both in this subject and in others not obviously connected with it, I hope to exhibit the theory of the electro-tonic state in a form in which all its relations may be distinctly conceived without reference to analytical calculations.

Summary of the Theory of the Electro-tonic State.

We may conceive of the electro-tonic state at any point of space as a quantity determinate in magnitude and direction, and we may represent the electro-tonic condition of a portion of space by any mechanical system which has at every point some quantity, which may be a velocity, a displacement, or a force, whose direction and magnitude correspond to those of the supposed electro-tonic state. This representation involves no physical theory, it is only a kind of artificial notation. In analytical investigations we make use of the three components of the electro-tonic state, and call them electro-tonic functions. We take the resolved part of the electro-tonic intensity at every point of a closed curve, and find by integration what we may call the *entire electro-tonic intensity round the curve*.

PROP. I. *If on any surface a closed curve be drawn, and if the surface within it be divided into small areas, then the entire intensity round the closed curve is equal to the sum of the intensities round each of the small areas, all estimated in the same direction.*

For, in going round the small areas, every boundary line between two of them is passed along twice in opposite directions, and the intensity gained in the one case is lost in the other. Every effect of passing along the interior divisions is therefore neutralized, and the whole effect is that due to the exterior closed curve.

LAW I. *The entire electro-tonic intensity round the boundary of an element of surface measures the quantity of magnetic induction which passes through that surface, or, in other words, the number of lines of magnetic force which pass through that surface.*

By PROP. I. it appears that what is true of elementary surfaces is true also of surfaces of finite magnitude, and therefore any two surfaces which are bounded by the same closed curve will have the same quantity of magnetic induction through them.

LAW II. *The magnetic intensity at any point is connected with the quantity of magnetic induction by a set of linear equations, called the equations of conduction*.*

* See Art. (28).

LAW III. *The entire magnetic intensity round the boundary of any surface measures the quantity of electric current which passes through that surface.*

LAW IV. *The quantity and intensity of electric currents are connected by a system of equations of conduction.*

By these four laws the magnetic and electric quantity and intensity may be deduced from the values of the electro-tonic functions. I have not discussed the values of the units, as that will be better done with reference to actual experiments. We come next to the attraction of conductors of currents, and to the induction of currents within conductors.

LAW V. *The total electro-magnetic potential of a closed current is measured by the product of the quantity of the current multiplied by the entire electro-tonic intensity estimated in the same direction round the circuit.*

Any displacement of the conductors which would cause an increase in the potential will be assisted by a force measured by the rate of increase of the potential, so that the mechanical work done during the displacement will be measured by the increase of potential.

Although in certain cases a displacement in direction or alteration of intensity of the current might increase the potential, such an alteration would not itself produce work, and there will be no tendency towards this displacement, for alterations in the current are due to electro-motive force, not to electro-magnetic attractions, which can only act on the conductor.

LAW VI. *The electro-motive force on any element of a conductor is measured by the instantaneous rate of change of the electro-tonic intensity on that element, whether in magnitude or direction.*

The electro-motive force in a closed conductor is measured by the rate of change of the entire electro-tonic intensity round the circuit referred to unit of time. It is independent of the nature of the conductor, though the current produced varies inversely as the resistance; and it is the same in whatever way the change of electro-tonic intensity has been produced, whether by motion of the conductor or by alterations in the external circumstances.

In these six laws I have endeavoured to express the idea which I believe to be the mathematical foundation of the modes of thought indicated in the *Experimental Researches*. I do not think that it contains even the shadow of a true physical theory; in fact, its chief merit as a temporary instrument of research is that it does not, even in appearance, account for anything.

There exists however a professedly physical theory of electro-dynamics, which is so elegant, so mathematical, and so entirely different from anything in this paper, that I must state its axioms, at the risk of repeating what ought to be well known. It is contained in M. W. Weber's *Electro-dynamic Measurements*, and may be found in the Transactions of the Leibnitz Society, and of the Royal Society of Sciences of Saxony*. The assumptions are,

(1) That two particles of electricity when in motion do not repel each other with the same force as when at rest, but that the force is altered by a quantity depending on the relative motion of the two particles, so that the expression for the repulsion at distance r is

* When this was written, I was not aware that part of M. Weber's Memoir is translated in Taylor's *Scientific Memoirs*, Vol. V. Art. XIV. The value of his researches, both experimental and theoretical, renders the study of his theory necessary to every electrician.

$$\frac{ee'}{r^2} \left(1 + a \frac{dr}{dt} \right)^2 + br \frac{d^2r}{dt^2}.$$

(2) That when electricity is moving in a conductor, the velocity of the positive fluid *relatively to the matter of the conductor* is equal and opposite to that of the negative fluid.

(3) The total action of one conducting element on another is the resultant of the mutual actions of the masses of electricity of both kinds which are in each.

(4) The electro-motive force at any point is the difference of the forces acting on the positive and negative fluids.

From these axioms are deducible Ampère's laws of the attraction of conductors, and those of Neumann and others, for the induction of currents. Here then is a really physical theory, satisfying the required conditions better perhaps than any yet invented, and put forth by a philosopher whose experimental researches form an ample foundation for his mathematical investigations. What is the use then of imagining an electro-tonic state of which we have no distinctly physical conception, instead of a formula of attraction which we can readily understand? I would answer, that it is a good thing to have two ways of looking at a subject, and to admit that there *are* two ways of looking at it. Besides, I do not think that we have any right at present to understand the action of electricity, and I hold that the chief merit of a temporary theory is, that it shall guide experiment, without impeding the progress of the true theory when it appears. There are also objections to making any ultimate forces in nature depend on the velocity of the bodies between which they act. If the forces in nature are to be reduced to forces acting between particles, the principle of the Conservation of Force requires that these forces should be in the line joining the particles and functions of the distance only. The experiments of M. Weber on the reverse polarity of diamagnetics, which have been recently repeated by Professor Tyndall, establish a fact which is equally a consequence of M. Weber's theory of electricity and of the theory of lines of force.

With respect to the history of the present theory, I may state that the recognition of certain mathematical functions as expressing the "electro-tonic state" of Faraday, and the use of them in determining electro-dynamic potentials and electro-motive forces, is, as far as I am aware, original; but the distinct conception of the possibility of the mathematical expressions arose in my mind from the perusal of Prof. W. Thomson's papers "On a Mechanical Representation of Electric, Magnetic and Galvanic Forces," *Cambridge and Dublin Mathematical Journal*, January, 1847, and his "Mathematical Theory of Magnetism," *Philosophical Transactions*, Part I. 1851, Art. 78, &c. As an instance of the help which may be derived from other physical investigations, I may state that after I had investigated the Theorems of this paper Professor Stokes pointed out to me the use which he had made of similar expressions in his "Dynamical Theory of Diffraction," Section 1, *Cambridge Transactions*, Vol. IX. Part 1. Whether the theory of these functions, considered with reference to electricity, may lead to new mathematical ideas to be employed in physical research, remains to be seen. I propose in the rest of this paper to discuss a few electrical and magnetic problems with reference to spheres. These are intended merely as concrete examples of the methods of which the theory has been given; I reserve the detailed investigation of cases chosen with special reference to experiment till I have the means of testing their results.

EXAMPLES.

I. *Theory of Electrical Images.*

The method of Electrical Images, due to Prof. W. Thomson*, by which the theory of spherical conductors has been reduced to great geometrical simplicity, becomes even more simple when we see its connexion with the methods of this paper. We have seen that the pressure at any point in a uniform medium, due to a spherical shell (radius = a) giving out fluid at the rate of $4\pi Pa^2$ units in unit of time, is $kP \frac{a^2}{r}$ outside the shell, and kPa inside it, where r is the distance of the point from the centre of the shell.

If there be two shells, one giving out fluid at a rate $4\pi Pa^2$, and the other absorbing at the rate $4\pi P'a'^2$, then the expression for the pressure will be, outside the shells,

$$p = 4\pi P \frac{a^2}{r} - 4\pi P' \frac{a'^2}{r'},$$

where r and r' are the distances from the centres of the two shells. Equating this expression to zero we have, as the surface of no pressure, that for which

$$\frac{r'}{r} = \frac{P'a'^2}{Pa^2}.$$

Now the surface, for which the distances to two fixed points have a given ratio, is a sphere of which the centre O is in the line joining the centres of the shells CC' produced, so that

$$CO = CC' \frac{\sqrt{P'a'^2}}{\sqrt{Pa^2} - \sqrt{P'a'^2}}$$

and its radius

$$= CC' \frac{Pa^2 \cdot P'a'^2}{\sqrt{Pa^2}^2 - \sqrt{P'a'^2}^2}.$$

If at the centre of this sphere we place another source of the fluid, then the pressure due to this source must be added to that due to the other two; and since this additional pressure depends only on the distance from the centre, it will be constant at the surface of the sphere, where the pressure due to the two other sources is zero.

We have now the means of arranging a system of sources within a given sphere, so that when combined with a given system of sources outside the sphere, they shall produce a given constant pressure at the surface of the sphere.

* See a series of papers "On the Mathematical Theory of Electricity," in the *Cambridge and Dublin Math. Jour.*, beginning March, 1846.

Let a be the radius of the sphere, and p the given pressure, and let the given sources be at distances b_1, b_2 &c. from the centre, and let their rates of production be $4\pi P_1, 4\pi P_2$ &c.

Then if at distances $\frac{a^3}{b_1}, \frac{a^3}{b_2}$ &c. (measured in the same direction as b_1, b_2 &c. from the centre) we place negative sources whose rates are

$$-4\pi P_1 \frac{a}{b_1}, -4\pi P_2 \frac{a}{b_2} \text{ \&c.}$$

the pressure at the surface $r = a$ will be reduced to zero. Now placing a source $4\pi \frac{pa}{k}$ at the centre, the pressure at the surface will be uniform and equal to p .

The whole amount of fluid emitted by the surface $r = a$ may be found by adding the rates of production of the sources within it. The result is

$$4\pi a \left\{ \frac{p}{k} - \frac{P_1}{b_1} - \frac{P_2}{b_2} - \text{\&c.} \right\}.$$

To apply this result to the case of a conducting sphere, let us suppose the external sources $4\pi P_1, 4\pi P_2$ to be small electrified bodies, containing e_1, e_2 of positive electricity. Let us also suppose that the whole charge of the conducting sphere is $= E$ previous to the action of the external points. Then all that is required for the complete solution of the problem is, that the surface of the sphere shall be a surface of equal potential, and that the total charge of the surface shall be E .

If by any distribution of imaginary sources within the spherical surface we can effect this, the value of the corresponding potential outside the sphere is the true and only one. The potential inside the sphere must really be constant and equal to that at the surface.

We must therefore find the *images* of the external electrified points, that is, for every point at distance b from the centre we must find a point on the same radius at a distance $\frac{a^2}{b}$, and at that point we must place a quantity $= -e \frac{a}{b}$ of imaginary electricity.

At the centre we must put a quantity E' such that

$$E' = E + e_1 \frac{a}{b_1} + e_2 \frac{a}{b_2} + \text{\&c.};$$

then if R be the distance from the centre, r_1, r_2 &c. the distances from the electrified points, and r'_1, r'_2 the distances from their images at any point outside the sphere, the potential at that point will be

$$\begin{aligned} p &= \frac{E'}{R} + e_1 \left(\frac{1}{r_1} - \frac{a}{b_1} \frac{1}{r'_1} \right) + e_2 \left(\frac{1}{r_2} - \frac{a}{b_2} \frac{1}{r'_2} \right) + \text{\&c.} \\ &= \frac{E}{R} + \frac{e_1}{b_1} \left(\frac{a}{R} + \frac{b_1}{r_1} - \frac{a}{r'_1} \right) + \frac{e_2}{b_2} \left(\frac{a}{R} + \frac{b_2}{r_2} - \frac{a}{r'_2} \right) + \text{\&c.} \end{aligned}$$

This is the value of the potential outside the sphere. At the surface we have

$$R=a \text{ and } \frac{b_1}{r_1} = \frac{a}{r_1}, \quad \frac{b_2}{r_2} = \frac{a}{r_2} \text{ \&c.}$$

so that at the surface

$$p = \frac{E}{a} + \frac{e_1}{b_1} + \frac{e_2}{b_2} + \text{\&c.}$$

and this must also be the value of p for any point within the sphere.

For the application of the principle of electrical images the reader is referred to Prof. Thomson's papers in the *Cambridge and Dublin Mathematical Journal*. The only case which we shall consider is that in which $\frac{e_1}{b_1^2} = I$, and b_1 is infinitely distant along axis of x , and $E=0$.

The value p outside the sphere becomes then

$$p = Ix \left(- \frac{a^3}{r^3} \right),$$

and inside $p=0$.

II. On the effect of a paramagnetic or diamagnetic sphere in a uniform field of magnetic force*.

The expression for the potential of a small magnet placed at the origin of co-ordinates in the direction of the axis of x is

$$\frac{d}{dx} \left(\frac{m}{r} \right) = - lm \frac{x}{r^3}.$$

The effect of the sphere in disturbing the lines of force may be supposed as a first hypothesis to be similar to that of a small magnet at the origin, whose strength is to be determined. (We shall find this to be accurately true.)

Let the value of the potential undisturbed by the presence of the sphere be

$$p = Ix.$$

Let the sphere produce an additional potential, which for external points is

$$p' = A \frac{a^3}{r^3} x,$$

and let the potential within the sphere be

$$p_1 = Bx.$$

Let k' be the coefficient of resistance outside, and k inside the sphere, then the conditions to be fulfilled are, that the interior and exterior potential should coincide at the

* See Prof. Thomson, on the Theory of Magnetic Induction, *Phil. Mag.* March, 1851. The inductive capacity of the sphere, according to that paper, is the ratio of the quantity of magnetic induction (not the intensity) within the sphere to that without. It is therefore equal to $\frac{1}{I} B \frac{k'}{k} = \frac{3k'}{2k+k}$, according to our notation.

surface, and that the induction through the surface should be the same whether deduced from the external or the internal potential. Putting $x = r \cos \theta$, we have for the external potential

$$p = \left(Ir + A \frac{a^3}{r^3} \right) \cos \theta,$$

and for the internal

$$p_1 = Br \cos \theta,$$

and these must be identical when $r = a$, or

$$I + A = B.$$

The induction through the surface in the external medium is

$$\frac{1}{k'} \frac{dp}{dr_{r=a}} = \frac{1}{k'} (I - 2A) \cos \theta,$$

and that through the interior surface is

$$\frac{1}{k} \frac{dp_1}{dr_{r=a}} = \frac{1}{k} B \cos \theta;$$

$$\text{and } \therefore \frac{1}{k'} (I - 2A) = \frac{1}{k} B.$$

These equations give

$$A = \frac{k - k'}{2k + k'} I, \quad B = \frac{3k}{2k + k'} I.$$

The effect outside the sphere is equal to that of a little magnet whose length is l and moment ml , provided

$$ml = \frac{k - k'}{2k + k'} a^3 I.$$

Suppose this uniform field to be that due to terrestrial magnetism, then, if k is less than k' as in paramagnetic bodies, the marked end of the equivalent magnet will be turned to the north. If k is greater than k' as in diamagnetic bodies, the unmarked end of the equivalent magnet would be turned to the north.

III. *Magnetic field of variable Intensity.*

Now suppose the intensity in the undisturbed magnetic field to vary in magnitude and direction from one point to another, and that its components in xyz are represented by $\alpha_1 \beta_1 \gamma_1$, then, if as a first approximation we regard the intensity within the sphere as sensibly equal to that at the centre, the change of potential outside the sphere arising from the presence of

the sphere, disturbing the lines of force, will be the same as that due to three small magnets at the centre, with their axes parallel to x , y , and z , and their moments equal to

$$\frac{k - k'}{2k + k'} a^3 \alpha, \quad \frac{k - k'}{2k + k'} a^3 \beta, \quad \frac{k - k'}{2k + k'} a^3 \gamma.$$

The actual distribution of potential within and without the sphere may be conceived as the result of a distribution of imaginary magnetic matter on the surface of the sphere; but since the external effect of this superficial magnetism is exactly the same as that of the three small magnets at the centre, the mechanical effect of external attractions will be the same as if the three magnets really existed.

Now let three small magnets whose lengths are $l_1 l_2 l_3$, and strengths $m_1 m_2 m_3$ exist at the point xyx with their axes parallel to the axes of xyx ; then, resolving the forces on the three magnets in the direction of X , we have

$$\begin{aligned} -X &= m_1 \begin{pmatrix} \alpha_1 + \frac{da l_1}{dx 2} \\ -\alpha_1 + \frac{da l_1}{dx 2} \end{pmatrix} + m_2 \begin{pmatrix} \alpha_1 + \frac{da l_2}{dy 2} \\ -\alpha_1 + \frac{da l_2}{dy 2} \end{pmatrix} + m_3 \begin{pmatrix} \alpha + \frac{da l_3}{dz 2} \\ -\alpha + \frac{da l_3}{dz 2} \end{pmatrix} \\ &= m_1 l_1 \frac{da}{dx} + m_2 l_2 \frac{da}{dy} + m_3 l_3 \frac{da}{dz}. \end{aligned}$$

Substituting the values of the moments of the imaginary magnets

$$-X = \frac{k - k'}{2k + k'} a^3 \left(\alpha \frac{da}{dx} + \beta \frac{d\beta}{dx} + \gamma \frac{d\gamma}{dx} \right) = \frac{k - k'}{2k + k'} \frac{a^3}{2} \frac{d}{dx} (\alpha^2 + \beta^2 + \gamma^2).$$

The force impelling the sphere in the direction of x is therefore dependent on the variation of the square of the intensity or $(\alpha^2 + \beta^2 + \gamma^2)$, as we move along the direction of x , and the same is true for y and z , so that the law is, that the force acting on diamagnetic spheres is from places of greater to places of less intensity of magnetic force, and that in similar distributions of magnetic force it varies as the mass of the sphere and the square of the intensity.

It is easy by means of Laplace's Coefficients to extend the approximation to the value of the potential as far as we please, and to calculate the attraction. For instance, if a north or south magnetic pole whose strength is M , be placed at a distance b from a diamagnetic sphere, radius a , the repulsion will be

$$R = M^2 (k - k') \frac{a^3}{b^5} \left(\frac{2 \cdot 1}{2k + k'} + \frac{3 \cdot 2}{3k + 2k'} \frac{a^2}{b^2} + \frac{4 \cdot 3}{4k + 3k'} \frac{a^4}{b^4} + \&c. \right)$$

When $\frac{a}{b}$ is small, the first term gives a sufficient approximation. The repulsion is then as the square of the strength of the pole and the mass of the sphere directly and the fifth power of the distance inversely, considering the pole as a point.

IV. *Two Spheres in uniform field.*

Let two spheres of radius a be connected together so that their centres are kept at a distance b , and let them be suspended in a uniform magnetic field, then, although each sphere by itself would have been in equilibrium at any part of the field, the disturbance of the field will produce forces tending to make the balls set in a particular direction.

Let the centre of one of the spheres be taken as origin, then the undisturbed potential is

$$p = I r \cos \theta,$$

and the potential due to the sphere is

$$p' = I \frac{k - k' a^3}{2k + k' r^3} \cos \theta.$$

The whole potential is therefore equal to

$$I \left(r + \frac{k - k' a^3}{2k + k' r^3} \right) \cos \theta = p,$$

$$\frac{dp}{dr} = I \left(1 - 2 \frac{k - k' a^3}{2k + k' r^3} \right) \cos \theta,$$

$$\frac{1}{r} \frac{dp}{d\theta} = -I \left(1 + \frac{k - k' a^3}{2k + k' r^3} \right) \sin \theta, \quad \frac{dp}{d\phi} = 0,$$

$$\therefore i^2 = \left[\frac{dp}{dr} \right]^2 + \frac{1}{r^2} \left[\frac{dp}{d\theta} \right]^2 + \frac{1}{r^2 \sin^2 \theta} \left[\frac{dp}{d\phi} \right]^2 = I^2 \left\{ 1 + \frac{k - k' a^3}{2k + k' r^3} (1 - 3 \cos^2 \theta) + \frac{k - k'}{2k + k'} \frac{a^6}{r^6} (1 + 3 \cos^2 \theta) \right\}.$$

This is the value of the square of the intensity at any point. The moment of the couple tending to turn the combination of balls in the direction of the original force

$$L = \frac{1}{2} \frac{d}{d\theta} i^2 \left(\frac{k - k'}{2k + k'} a^3 \right) \text{ when } r = b,$$

$$L = \frac{3}{2} I^2 \frac{k - k'}{2k + k'} \frac{a^6}{b^3} \left(1 - \frac{k - k'}{2k + k'} \frac{a^3}{b^3} \right) \sin 2\theta.$$

This expression, which must be positive, since b is greater than a , gives the moment of a force tending to turn the line joining the centres of the spheres towards the original lines of force.

Whether the spheres are magnetic or diamagnetic they tend to set in the *axial* direction, and that without distinction of north and south. If, however, one sphere be magnetic and the other diamagnetic, the line of centres will set equatorially. The magnitude of the force depends on the square of $(k - k')$, and is therefore quite insensible except in iron*.

V. *Two Spheres between the poles of a Magnet.*

Let us next take the case of the same balls placed not in a uniform field but between a north and a south pole, $\pm M$, distant $2c$ from each other in the direction of x .

* See Prof. Thomson in *Phil. Mag.* March, 1851.

The expression for the potential, the middle of the line joining the poles being the origin, is

$$p = M \left(\frac{1}{\sqrt{c^2 + r^2 - 2 \cos \theta cr}} - \frac{1}{\sqrt{c^2 + r^2 + 2 \cos \theta cr}} \right).$$

From this we find as the value of I^2 ,

$$I^2 = \frac{4M^2}{c^4} \left(1 - 3 \frac{r^2}{c^2} + 9 \frac{r^4}{c^4} \cos^2 \theta \right);$$

$$\therefore I \frac{dI}{d\theta} = -18 \frac{M^2}{c^6} r^2 \sin 2\theta,$$

and the moment to turn a pair of spheres (radius a , distance $2b$) in the direction in which θ is increased is

$$-36 \frac{k - k'}{2k + k'} \frac{M^2 a^3 b^2}{c^6} \sin 2\theta.$$

This force, which tends to turn the line of centres equatorially for diamagnetic and axially for magnetic spheres, varies directly as the square of the strength of the magnet, the cube of the radius of the spheres and the square of the distance of their centres, and inversely as the sixth power of the distance of the poles of the magnet, considered as points. As long as these poles are near each other this action of the poles will be much stronger than the mutual action of the spheres, so that as a general rule we may say that elongated bodies set axially or equatorially between the poles of a magnet according as they are magnetic or diamagnetic. If, instead of being placed between two poles very near to each other, they had been placed in a uniform field such as that of terrestrial magnetism or that produced by a spherical electro-magnet (see Ex. VIII.), an elongated body would set axially whether magnetic or diamagnetic.

In all these cases the phenomena depend on $k - k'$, so that the sphere conducts itself magnetically or diamagnetically according as it is more or less magnetic, or less or more diamagnetic than the medium in which it is placed.

VI. *On the Magnetic Phenomena of a Sphere cut from a substance whose coefficient of resistance is different in different directions.*

Let the axes of magnetic resistance be parallel throughout the sphere, and let them be taken for the axes of x, y, z . Let k_1, k_2, k_3 , be the coefficients of resistance in these three directions, and let k' be that of the external medium, and a the radius of the sphere. Let I be the undisturbed magnetic intensity of the field into which the sphere is introduced, and let its direction-cosines be l, m, n .

Let us now take the case of a homogeneous sphere whose coefficient is k_1 placed in a uniform magnetic field whose intensity is II in the direction of x . The resultant potential outside the sphere would be

$$p' = II \left(1 + \frac{k_1 - k'}{2k_1 + k'} \frac{a^3}{r^3} \right) x,$$

and for internal points

$$p_1 = II \frac{3k_1}{2k_1 + k'} x.$$

So that in the interior of the sphere the magnetization is entirely in the direction of x . It is therefore quite independent of the coefficients of resistance in the directions of x and y , which may be changed from k_1 into k_2 and k_3 without disturbing this distribution of magnetism. We may therefore treat the sphere as homogeneous for each of the three components of I , but we must use a different coefficient for each. We find for external points

$$p' = I \left\{ lx + my + nz + \left(\frac{k_1 - k'}{2k_1 + k'} lx + \frac{k_2 - k'}{2k_2 + k'} my + \frac{k_3 - k'}{2k_3 + k'} nz \right) \frac{a^3}{r^3} \right\},$$

and for internal points

$$p_1 = I \left(\frac{3k_1}{2k_1 + k'} lx + \frac{3k_2}{2k_2 + k'} my + \frac{3k_3}{2k_3 + k'} nz \right).$$

The external effect is the same as that which would have been produced if the small magnet whose moments are

$$\frac{k_1 - k'}{2k_1 + k'} lIa^3, \quad \frac{k_2 - k'}{2k_2 + k'} mIa^3, \quad \frac{k_3 - k'}{2k_3 + k'} nIa^3$$

had been placed at the origin with their directions coinciding with the axes of x, y, z . The effect of the original force I in turning the sphere about the axis of x may be found by taking the moments of the components of that force on these equivalent magnets. The moment of the force in the direction of y acting on the third magnet is

$$\frac{k_3 - k'}{2k_3 + k'} mnI^2 a^3,$$

and that of the force in z on the second magnet is

$$- \frac{k_2 - k'}{2k_2 + k'} mnI^2 a^3.$$

The whole couple about the axis of x is therefore

$$\frac{3k' (k_3 - k_2)}{(2k_3 + k')(2k_2 + k')} mnI^2 a^3,$$

tending to turn the sphere round from the axis of y towards that of z . Suppose the sphere to be suspended so that the axis of x is vertical, and let I be horizontal, then if θ be the angle which the axis of y makes with the direction of I , $m = \cos \theta$, $n = -\sin \theta$, and the expression for the moment becomes

$$\frac{3}{2} \frac{k' (k_2 - k_3)}{(2k_2 + k')(2k_3 + k')} I^2 a^3 \sin 2\theta$$

tending to increase θ . The axis of least resistance therefore sets axially, but with either end indifferently towards the north.

Since in all bodies, except iron, the values of k are nearly the same as in a vacuum,

the coefficient of this quantity can be but little altered by changing the value of k' to k , the value in space. The expression then becomes

$$\frac{1}{6} \frac{k_2 - k_3}{k} I^2 a^3 \sin 2\theta,$$

independent of the external medium*.

VII. *Permanent magnetism in a spherical shell.*

The case of a homogeneous shell of a diamagnetic or paramagnetic substance presents no difficulty. The intensity within the shell is less than what it would have been if the shell were away, whether the substance of the shell be diamagnetic or paramagnetic. When the resistance of the shell is infinite, and when it vanishes, the intensity within the shell is zero.

In the case of no resistance the entire effect of the shell on any point, internal or external, may be represented by supposing a superficial stratum of magnetic matter spread over the outer surface, the density being given by the equation

$$\rho = 3I \cos \theta.$$

Suppose the shell now to be converted into a permanent magnet, so that the distribution of imaginary magnetic matter is invariable, then the external potential due to the shell will be

$$p' = -I \frac{a^3}{r^2} \cos \theta,$$

and the internal potential

$$p_1 = -Ir \cos \theta.$$

Now let us investigate the effect of filling up the shell with some substance of which the resistance is k , the resistance in the external medium being k' . The thickness of the magnetized shell may be neglected. Let the magnetic moment of the permanent magnetism be Ia^3 , and that of the imaginary superficial distribution due to the medium $k = Aa^3$. Then the potentials are

$$\text{external } p' = (I + A) \frac{a^3}{r^2} \cos \theta, \quad \text{internal } p_1 = (I + A) r \cos \theta.$$

The distribution of real magnetism is the same before and after the introduction of the medium k , so that

$$\frac{1}{k'} I + \frac{2}{k'} I = \frac{1}{k} (I + A) + \frac{2}{k} (I + A),$$

$$\text{or } A = \frac{k - k'}{2k + k'} I.$$

The external effect of the magnetized shell is increased or diminished according as k is greater or less than k' . It is therefore increased by filling up the shell with diamagnetic matter, and diminished by filling it with paramagnetic matter, such as iron.

* Taking the more general case of magnetic induction referred to in Art. (28), we find, in the expression for the moment of the magnetic forces, a constant term depending on T , besides those terms which depend on sines and cosines of θ . The result is, that in every complete revolution in the negative direction round the axis of T , a certain positive amount of work is gained; but, since no inexhaustible source of work can exist

in nature, we must admit that $T=0$ in all substances, with respect to magnetic induction. This argument does not hold in the case of electric conduction, or in the case of a body through which heat or electricity is passing, for such states are maintained by the continual expenditure of work. See Prof. Thomson, *Phil. Mag.* March, 1851, p. 186.

VIII. *Electro-magnetic spherical shell.*

Let us take as an example of the magnetic effects of electric currents, an electro-magnet in the form of a thin spherical shell. Let its radius be a , and its thickness t , and let its external effect be that of a magnet whose moment is Ia^3 . Both within and without the shell the magnetic effect may be represented by a potential, but within the substance of the shell, where there are electric currents, the magnetic effects cannot be represented by a potential. Let p' , p_1 be the external and internal potentials,

$$p' = I \frac{a^3}{r^2} \cos \theta, \quad p_1 = Ar \cos \theta,$$

and since there is no permanent magnetism, $\frac{dp'}{dr} = \frac{dp_1}{dr}$, when $r = a$,

$$A = -2I.$$

If we draw any closed curve cutting the shell at the equator, and at some other point for which θ is known, then the total magnetic intensity round this curve will be $3Ia \cos \theta$, and as this is a measure of the total electric current which flows through it, the quantity of the current at any point may be found by differentiation. The quantity which flows through the element $t d\theta$ is $-3Ia \sin \theta d\theta$, so that the quantity of the current referred to unit of area of section is

$$-3I \frac{a}{t} \sin \theta.$$

If the shell be composed of a wire coiled round the sphere so that the number of coils to the inch varies as the sine of θ , then the external effect will be nearly the same as if the shell had been made of a uniform conducting substance, and the currents had been distributed according to the law we have just given.

If a wire conducting a current of strength I_2 be wound round a sphere of radius a so that the distance between successive coils measured along the axis of x is $\frac{2a}{n}$, then there will be n coils altogether, and the value of I_1 for the resulting electro-magnet will be

$$I_1 = \frac{n}{6a} I_2.$$

The potentials, external and internal, will be

$$p' = I_2 \frac{n}{6} \frac{a^2}{r^2} \cos \theta, \quad p_1 = -2I_2 \frac{n}{6} \frac{r}{a} \cos \theta.$$

The interior of the shell is therefore a uniform magnetic field.

IX. *Effect of the core of the electro-magnet.*

Now let us suppose a sphere of diamagnetic or paramagnetic matter introduced into the electro-magnetic coil. The result may be obtained as in the last case, and the potentials become

$$p' = I_2 \frac{n}{6} \frac{3k'}{2k + k'} \frac{a^2}{r^2} \cos \theta, \quad p_1 = -2I_2 \frac{n}{6} \frac{3k}{2k + k'} \frac{r}{a} \cos \theta.$$

The external effect is greater or less than before, according as k' is greater or less than k , that is, according as the interior of the sphere is magnetic or diamagnetic with

respect to the external medium, and the internal effect is altered in the opposite direction, being greatest for a diamagnetic medium.

This investigation explains the effect of introducing an iron core into an electro-magnet. If the value of k for the core were to vanish altogether, the effect of the electro-magnet would be three times that which it has without the core. As k has always a finite value, the effect of the core is less than this.

In the interior of the electro-magnet we have a uniform field of magnetic force, the intensity of which may be increased by surrounding the coil with a shell of iron. If $k' = 0$, and the shell infinitely thick, the effect on internal points would be tripled.

The effect of the core is greater in the case of a cylindrical magnet, and greatest of all when the core is a ring of soft iron.

X. *Electro-tonic functions in spherical electro-magnet.*

Let us now find the electro-tonic functions due to this electro-magnet.

They will be of the form

$$a_0 = 0, \quad \beta_0 = \omega x, \quad \gamma_0 = -\omega y,$$

where ω is some function of r . Where there are no electric currents, we must have a_2, b_2, c_2 each = 0, and this implies

$$\frac{d}{dr} \left(s\omega + r \frac{d\omega}{dr} \right) = 0,$$

the solution of which is

$$\omega = C_1 + \frac{C_2}{r^3}.$$

Within the shell ω cannot become infinite; therefore $\omega = C_1$ is the solution, and outside a must vanish at an infinite distance, so that

$$\omega = \frac{C_2}{r^3}$$

is the solution outside. The magnetic quantity within the shell is found by last article to be

$$-2I_2 \frac{n}{6a} \frac{s}{2k+k'} = a_1 = \frac{d\beta_0}{dr} - \frac{d\gamma_0}{dy} = 2C_1;$$

therefore within the sphere

$$\omega_0 = -\frac{I_2 n}{2a} \frac{1}{3k+k'}.$$

Outside the sphere we must determine ω so as to coincide at the surface with the internal value. The external value is therefore

$$\omega = -\frac{I_2 n}{2a} \frac{1}{3k+k'} \frac{a^3}{r^3},$$

where the shell containing the currents is made up of n coils of wire, conducting a current of total quantity I_2 .

Let another wire be coiled round the shell according to the same law, and let the total number of coils be n' ; then the total electro-tonic intensity EI_2 round the second coil is found by integrating

$$EI_2 = \int_0^{2\pi} \omega a \sin \theta ds,$$

along the whole length of the wire. The equation of the wire is

$$\cos \theta = \frac{\phi}{n' \pi},$$

where n is a large number; and therefore

$$\begin{aligned} ds &= a \sin \theta d\phi, \\ &= -an' \pi \sin^2 \theta d\theta, \end{aligned}$$

$$\therefore EI_2 = \frac{4\pi}{3} \omega a^2 n' = -\frac{2\pi}{3} ann' I \frac{1}{3k + k'}$$

E may be called the electro-tonic coefficient for the particular wire.

XI. *Spherical electro-magnetic Coil-Machine.*

We have now obtained the electro-tonic function which defines the action of the one coil on the other. The action of each coil on itself is found by putting n^2 or n'^2 for nn' . Let the first coil be connected with an apparatus producing a variable electro-motive force F . Let us find the effects on both wires, supposing their total resistances to be R and R' , and the quantity of the currents I and I' .

Let N stand for $\frac{2\pi}{3} \frac{a}{(3k + k')}$, then the electro-motive force of the first wire on the second is

$$- Nnn' \frac{dI}{dt}.$$

That of the second on itself is

$$- Nn'^2 \frac{dI'}{dt}.$$

The equation of the current in the second wire is therefore

$$- Nnn' \frac{dI}{dt} - Nn'^2 \frac{dI'}{dt} = R' I' \dots\dots\dots (1)$$

The equation of the current in the first wire is

$$- Nn^2 \frac{dI}{dt} - Nnn' \frac{dI'}{dt} + F = RI \dots\dots\dots (2)$$

Eliminating the differential coefficients, we get

$$\frac{R}{n} I - \frac{R'}{n'} I' = \frac{F}{n},$$

$$\text{and } N \left(\frac{n^2}{R} + \frac{n'^2}{R'} \right) \frac{dI}{dt} + I = \frac{F}{R} + N \frac{n'^2}{R'} \frac{dF}{dt} \dots\dots (3)$$

from which to find I and I' . For this purpose we require to know the value of F in terms of t .

Let us first take the case in which F is constant and I and I' initially = 0. This is the case of an electro-magnetic coil-machine at the moment when the connexion is made with the galvanic trough.

Putting $\frac{1}{2} \tau$ for $N \left(\frac{n^2}{R} + \frac{n'^2}{R'} \right)$ we find

$$I = \frac{F}{R} \left(1 - e^{-\frac{2t}{\tau}} \right),$$

$$I' = -F \frac{n'}{R'n} e^{-\frac{2t}{\tau}}.$$

The primary current increases very rapidly from 0 to $\frac{F}{R}$, and the secondary commences at $-\frac{F}{R} \frac{n'}{n}$ and speedily vanishes, owing to the value of τ being generally very small.

The whole work done by either current in heating the wire or in any other kind of action is found from the expression

$$\int_0^{\infty} I^2 R dt.$$

The total quantity of current is

$$\int_0^{\infty} I dt.$$

For the secondary current we find

$$\int_0^{\infty} I'^2 R' dt = \frac{F^2 n'^2}{R' n^2} \frac{\tau}{4}, \quad \int_0^{\infty} I' dt = \frac{F n'}{R' n} \frac{\tau}{2}.$$

The work done and the quantity of the current are therefore the same as if a current of quantity $I' = \frac{F n'}{2 R' n}$ had passed through the wire for a time τ , where

$$\tau = 2N \left(\frac{n^2}{R} + \frac{n'^2}{R'} \right).$$

This method of considering a variable current of short duration is due to Weber, whose experimental methods render the determination of the equivalent current a matter of great precision.

Now let the electro-motive force F suddenly cease while the current in the primary wire is I_0 and in the secondary = 0. Then we shall have for the subsequent time

$$I = I_0 e^{-\frac{2t}{\tau}}, \quad I' = \frac{I_0}{R} \frac{R n'}{n} e^{-\frac{2t}{\tau}}.$$

The equivalent currents are $\frac{1}{2} I_0$ and $\frac{1}{2} I_0 \frac{R}{R'} \frac{n'}{n}$, and their duration is τ .

When the communication with the source of the current is cut off, there will be a change of R . This will produce a change in the value of τ , so that if R be suddenly increased, the strength of the secondary current will be increased, and its duration diminished. This is the case in the ordinary coil-machines. The quantity N depends on the form of the machine, and may be determined by experiment for a machine of any shape.

XII. *Spherical shell revolving in magnetic field.*

Let us next take the case of a revolving shell of conducting matter under the influence of a uniform field of magnetic force. The phenomena are explained by Faraday in his *Experimental Researches*, Series II., and references are there given to previous experiments.

Let the axis of x be the axis of revolution, and let the angular velocity be ω . Let the magnetism of the field be represented in quantity by I , inclined at an angle θ to the direction of x , in the plane of xv .

Let R be the radius of the spherical shell, and T the thickness. Let the quantities $\alpha_0, \beta_0, \gamma_0$ be the electro-tonic functions at any point of space; $a_1, b_1, c_1, \alpha_1, \beta_1, \gamma_1$ symbols of magnetic quantity and intensity; $a_2, b_2, c_2, \alpha_2, \beta_2, \gamma_2$ of electric quantity and intensity. Let p_2 be the electric tension at any point,

$$\left. \begin{aligned} a_2 &= \frac{dp_2}{dx} + ka_2 \\ \beta_2 &= \frac{dp_2}{dy} + kb_2 \\ \gamma_2 &= \frac{dp_2}{dz} + kc_2 \end{aligned} \right\} \dots\dots\dots(1)$$

$$\frac{da_2}{dx} + \frac{db_2}{dy} + \frac{dc_2}{dz} = 0 \dots\dots\dots (2);$$

$$\therefore \frac{da_2}{dx} + \frac{d\beta_2}{dy} + \frac{d\gamma_2}{dz} = \nabla^2 p.$$

The expressions for $\alpha_0, \beta_0, \gamma_0$ due to the magnetism of the field are

$$\alpha_0 = A_0 + \frac{I}{2} y \cos \theta,$$

$$\beta_0 = B_0 + \frac{I}{2} (x \sin \theta - z \cos \theta),$$

$$\gamma_0 = C_0 - \frac{I}{2} y \sin \theta,$$

A_0, B_0, C_0 being constants; and the velocities of the particles of the revolving sphere are

$$\frac{dx}{dt} = -\omega y, \quad \frac{dy}{dt} = \omega x, \quad \frac{dz}{dt} = 0.$$

We have therefore for the electro-motive forces

$$\alpha_2 = -\frac{1}{4\pi} \frac{d\alpha_0}{dt} = -\frac{1}{4\pi} \frac{I}{2} \cos \theta \omega x,$$

$$\beta_2 = -\frac{1}{4\pi} \frac{d\beta_0}{dt} = \frac{1}{4\pi} \frac{I}{2} \cos \theta \omega y,$$

$$\gamma_2 = -\frac{1}{4\pi} \frac{d\gamma_0}{dt} = \frac{1}{4\pi} \frac{I}{2} \sin \theta \omega x.$$

Returning to equations (1), we get

$$\begin{aligned} k \left(\frac{db_2}{dz} - \frac{dc_2}{dy} \right) &= \frac{d\beta_2}{dz} - \frac{d\gamma_2}{dy} = 0, \\ k \left(\frac{dc_2}{dx} - \frac{da_2}{dz} \right) &= \frac{d\gamma_2}{dx} - \frac{d\alpha_2}{dz} = \frac{1}{4\pi} \frac{I}{2} \sin \theta \omega, \\ k \left(\frac{du_2}{dy} - \frac{db_2}{dx} \right) &= \frac{d\alpha_2}{dy} - \frac{d\beta_2}{dx} = 0. \end{aligned}$$

From which with equation (2) we find

$$\begin{aligned} a_2 &= -\frac{1}{k} \frac{1}{4\pi} \frac{I}{4} \sin \theta \omega x, \\ b_2 &= 0, \\ c_2 &= \frac{1}{k} \frac{1}{4\pi} \frac{I}{4} \sin \theta \omega x, \\ p_2 &= \frac{1}{16\pi} I \omega \{ (x^2 + y^2) \cos \theta - xz \sin \theta \}. \end{aligned}$$

These expressions would determine completely the motion of electricity in a revolving sphere if we neglect the action of these currents on themselves. They express a system of circular currents about the axis of y , the quantity of current at any point being proportional to the distance from that axis. The external magnetic effect will be that of a small magnet whose moment is $\frac{TR^3}{48\pi k} \omega I \sin \theta$, with its direction along the axis of y , so that the magnetism of the field would tend to turn it back to the axis of x^* .

The existence of these currents will of course alter the distribution of the electro-tonic functions, and so they will react on themselves. Let the final result of this action be a system of currents about an axis in the plane of xy inclined to the axis of x at an angle ϕ and producing an external effect equal to that of a magnet whose moment is $I'R^3$.

The magnetic inductive components within the shell are

$$\begin{aligned} I_1 \sin \theta - 2I' \cos \phi &\text{ in } x, \\ -2I' \sin \phi &\text{ in } y, \\ I_1 \cos \theta &\text{ in } z. \end{aligned}$$

Each of these would produce its own system of currents when the sphere is in motion, and these would give rise to new distributions of magnetism, which, when the velocity is uniform, must be the same as the original distribution,

$$\begin{aligned} (I_1 \sin \theta - 2I' \cos \phi) \text{ in } x &\text{ produces } 2 \frac{T}{48\pi k} \omega (I_1 \sin \theta - 2I' \cos \phi) \text{ in } y, \\ (-2I' \sin \phi) \text{ in } y &\text{ produces } 2 \frac{T}{48\pi k} \omega (2I' \sin \phi) \text{ in } x; \end{aligned}$$

$I_1 \cos \theta$ in z produces no currents.

* The expression for p_2 indicates a variable electric tension in the shell, so that currents might be collected by wires touching it at the equator and poles.

We must therefore have the following equations, since the state of the shell is the same at every instant,

$$I_1 \sin \theta - 2I' \cos \phi = I_1 \sin \theta + \frac{T}{24\pi k} \omega 2I' \sin \phi$$

$$- 2I' \sin \phi = \frac{T}{24\pi k} \omega (I_1 \sin \theta - 2I' \cos \phi),$$

whence

$$\cot \phi = -\frac{TR^3}{24\pi k} \omega, \quad I' = \frac{1}{2} \frac{\frac{T}{24\pi k} \omega}{\sqrt{1 + \frac{T}{24\pi k} \omega}}, I_1 \sin \theta.$$

To understand the meaning of these expressions let us take a particular case.

Let the axis of the revolving shell be vertical, and let the revolution be from north to west. Let I be the total intensity of the terrestrial magnetism, and let the dip be θ , then $I \cos \theta$ is the horizontal component in the direction of magnetic north.

The result of the rotation is to produce currents in the shell about an axis inclined at a small angle = $\tan^{-1} \frac{T}{24\pi k} \omega$ to the south of magnetic west, and the external effect of these currents is the same as that of a magnet whose moment is

$$\frac{1}{2} \frac{T\omega}{\sqrt{24\pi k}^2 + T^2 \omega^2} R^3 I \cos \theta.$$

The moment of the couple due to terrestrial magnetism tending to stop the rotation is

$$\frac{24\pi k}{2} \frac{T\omega}{24\pi k^2 + T^2 \omega^2} R^3 I^2 \cos^2 \theta,$$

and the loss of work due to this in unit of time is

$$\frac{24\pi k}{2} \frac{T\omega^2}{24\pi k^2 + T^2 \omega^2} R^3 I^2 \cos^2 \theta.$$

This loss of work is made up by an evolution of heat in the substance of the shell, as is proved by a recent experiment of M. Foucault, (see *Comptes Rendus*, xli. p. 450).

IV. *The Structure of the Athenian Trireme ; considered with reference to certain difficulties of interpretation.* By J. W. DONALDSON, D.D. late Fellow of Trinity College, Cambridge.

[Read November 6, 1856.]

THE formal recognition of philology, as one of the subjects for discussion at the meetings of the Cambridge Philosophical Society, seems to me to impose on those of the members, who have more especially devoted themselves to this branch of academic study, the duty of suggesting as soon as possible some discussion calculated to awaken an interest in this new or rather additional department of our transactions. And as pure linguistic investigation is a sealed book to many, and eminently uninviting to all those, who are not critical scholars by profession, I have thought it best to take an application of philological research, on which I have something new to offer, and which is, or ought to be, both intelligible and interesting to all, who care for the language or the doings of the ancient Greeks.

As the Athenians, at the time when their literature assumed its distinctive form, were pre-eminently a maritime people, it was to be expected that nautical terms would take their place among the most usual figures of speech. Many of their best writers had either, as we say, "served in the navy," or had become familiar with the language and habits of the sea-ports. Even if the wealthier men had not personally served as *strategi* or *trierarchs*, or had not made voyages for profit or pleasure, they had lounged in the dockyards and factories of the Piræus, and seen the triremes put to sea on some great expedition; and if the poorer citizens had not pulled the long oar on the upper benches, they had lived in familiar intercourse with many whose hands were hardened with constant rowing, and whose ears were ringing with the never ceasing drone of the pipe to which they kept stroke in the voyage or the onset of battle. It is not at all surprising then that Attic literature is full of direct allusions to the structure of the ship of war and to all the incidents of sea-life. And in point of fact nothing is more common than the occurrence of nautical metaphors. But although this has been duly noticed, and though much has been written on the subject, there are still some phrases in common use, which have not yet received an adequate explanation, and consequently some passages, which still require to be illustrated by a more complete and accurate investigation of the Athenian trireme. It is my intention, in the present paper, to submit to you some of the conclusions at which I have arrived after a renewed survey of the ancient authorities.

It is a well-known fact that ships of war in the most glorious days of the Athenian republic were mainly, if not entirely, triremes, or galleys with three banks of oars. This convenient form of the rowing-vessel, combining, as it seems, the maximum of speed and power, was invented by Ameinocles the Corinthian about 700 B. C. The elementary form, of which it

was an extension, and which kept its place by the side of the trireme, was the penteconter or single-banked galley with fifty rowers. The short flat-bottomed barges of the earliest seamen were not adapted either for rapid navigation or for warfare. And as soon as the Greek mariners put out to sea either to trade with or to plunder distant cities, they seem to have adopted the long sharp-prowed vessel with its twenty-five rowers on each side. Herodotus says expressly that the Phocæans, who navigated the Archipelago, the Adriatic, and the western Mediterranean as far as Tartessus, used for this purpose *οὐ στρογγύλησι νηυσί, ἀλλὰ πεντηκοντόροισι* (I. 163), and the mythical Argo, which represents the first of those voyages, half piratical, half commercial, which the Thessalians made into the Black Sea, was undoubtedly regarded as a penteconter. The tradition generally reckons fifty Argonauts, and it was not without a distinct reference to this, that Pindar describes the dragon killed by Jason as "bigger in length and breadth than a penteconter, which blows of steel have perfected" (*Pyth.* IV. 255). In these galleys it is presumed that all the rowers were armed men, and Homer is careful to tell us this in speaking of the penteconters which Philoctetes took to Troy (*Il.* II. 227). Whether the ships of the Bœotians, to which Homer gives a complement of 120 men (*Il.* II. 16), were biremes, or large penteconters, with double crews, is a point which can hardly be decided; Pliny mentions (*H. N.* VII. 57), on the authority of Damastes, a contemporary of Herodotus, that the Erythræans were the first to introduce biremes, but we do not know when this form was originally adopted, and it is clear that the galley with two banks was never very common. And Thucydides seems to have understood that the penteconters only were rowed by the soldiers, who in that case were bowmen, so that the other vessels would contain, beside the rowers, who served as archers, some seventy hoplites, who only pulled on an emergency. There is a special reason for coming to this conclusion. Thucydides (I. 10) speaks of the *περίνεψ* or supernumeraries in the ships which went to Troy, and limits them to the kings and their suite. But the Scholiast says that this term included all the *ἐπίβαται* or soldiers on board. Now in the nautical inscriptions published by Böckh, we have a particular class of oars called by this name, *αἱ περίνεψ κῶπαι*, and it is probable that these were intended to be used by the synonymous *ἐπίβαται* whenever additional hands were wanted, to make head against wind or tide.

All things considered, we may take the penteconter as the oldest and most permanent type of the Greek war-ship. Both with regard to the number of the crew, and the vessel's length and breadth of beam, it was the basis or starting-point of the trireme. The crew of the trireme consisted of about 170 rowers and 30 supernumeraries. As the length of the vessel over all from fore-castle to poop was greater than that of its keel, there were more seats for rowers in the upper tier than in the two lower tiers, and the Scholiast on Aristophanes (*Ran.* 1074) tells us that at the stern the first thranite sat before the first zygitæ, and the first zygitæ before the first thalamite. It seems indeed that there were 62 *θρανῖται*, or bench-rowers, in the highest tier, 54 *ζυγῖται* or cross-bit-rowers, on the second tier, and the same number of *θαλαμῖται*, or main-hold-rowers, on the lowest tier. Unless then some of the thranites were employed to work the two great oars, or *πηδάλια*, at the stern, they must have had four ports on each side more than the lower tiers. Supposing that the penteconter had exactly 50 rowers, it must have been nearly as long as the trireme, for it had 25 ports or

holes for the oars, whereas the corresponding or lower part of the trireme was pierced for 27 holes on each side. And as the *interscalmium*, or space between the ports, was two cubits (Vitruv. i. 2), or 3 feet 6 inches, we should require a length of 105 feet above, and 91 feet below, exclusively of the steerage and bow, or *parexeiresia*. That the trireme and the oldest penteconter were exactly of the same breadth of beam, I will prove directly. And of course the height was not increased more than was necessary for the accommodation of the additional tiers of rowers.

Having regard then to that permanence of numerical arrangements which is so remarkable among the ancient Greeks, we must see at once that the broad-side of the penteconter corresponded to the *enomoty* or *triakad*, a body of 25 to 30 men, sworn to act together, and constituting the basis of the Greek military system. Consequently, the whole crew of the penteconter corresponded to the *pentekostys*, and the crew of the trireme was a *lochus*, consisting, with the *epibatae*, of four *pentekostyes*, which was the Lacedæmonian arrangement at the first battle of Mantinea (Thuc. v. 68), or it was two *lochi* of 100 men each, if we prefer Xenophon's subdivision (*Rep. Lac.* ii. 4).

In regard to these general features all is plain enough. Our difficulty commences, when we come to speak of the arrangements for seating the three tiers of rowers, and it is here that I hope to clear up some obscurities, and throw a little new light on the subject. Dr Arnold has called this "an undiscoverable" or "unconquerable problem" (*Rom. Hist.* iii. 572 on Thucyd. iv. 32), and Mr James Smith, in his elaborate and interesting *Essay On the Voyage and Shipwreck of St Paul*, has proposed a solution quite at variance with the meaning of the Greek words which distinguish the classes of rowers*. Even Böckh, in his *Archives of the Athenian Navy*, can give us no definite information, and inclines to the erroneous belief that

* The following is Mr Smith's transverse section of a trireme. (*Voyage and Shipwreck of St Paul*, p. 194.)

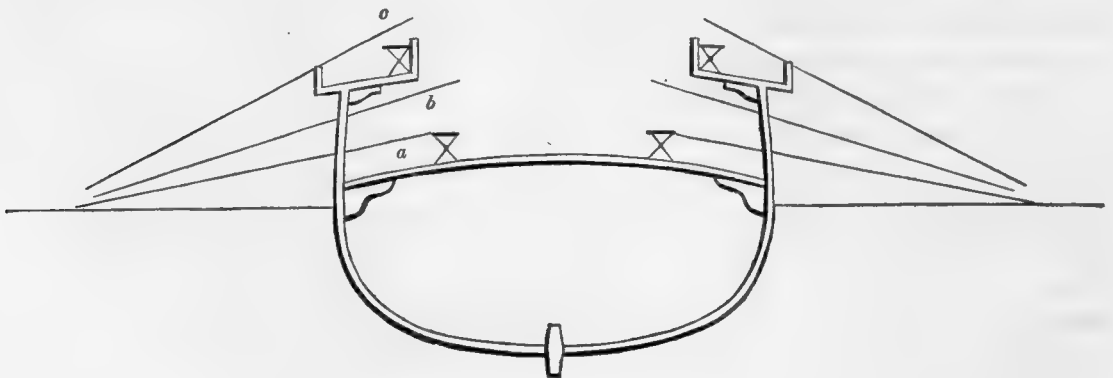

- a. Oar of thalamite seated on deck.
- b. Oar of zygitæ seated on stool on deck.
- c. Oar of thranite seated on stool on gangway.

Besides the objection stated in the text, that this arrangement will not explain the Greek names of the three tiers of rowers, it is impossible to conceive that the best rowers should have been placed on a platform within reach of the enemies' shot.

the rowers of all three tiers were furnished with seats of the same kind attached to the ribs of the vessels. I shall now endeavour to show, I believe for the first time, that the names of the three tiers of rowers accurately describe the manner in which they worked in the ships.

I. *The Zygita.*

There is a very primitive description of the structure of a Greek ship in the *Odyssey* v. 243 sqq., but we can infer from it that the ribs were always bound together with cross-beams before they were covered with planks. These cross-beams or cross-bits are called ἴκρια in the passage to which I refer, a name elsewhere limited to the planks of the partial deck fore and aft, which till a late period was the only κατάστρωμα of a war-ship. As the main-yard is termed the ἐπίκριον in this passage, and as the Christian cross was designated as an ἴκριον, we may conclude that the word implied a transverse or cross direction of these timbers; the root is probably that of ἰκό-μην, and therefore, as we shall see, the word is synonymous with σέλμα. These cross-bits are called κληῖδες in Homer, because, like the collar-bone, they locked together the two sides of the ship. The poets call them σέλματα, a word containing the old root *sel* or *sal*, "to go" (*New Crat.* § 269), and implying that they furnished the means of walking from one end to the other of the undecked vessel. The common name, retained to the last in the Athenian navy, was ζυγά, "the yokes" or bridges which joined the opposite sides of the ship. There is a reason for these changes of designation. In a mere pinnace, like that constructed by Ulysses, there would be no occasion for a hold, and the cross-planks might be placed close together, like the foot-boards of a boat. In this case, ἴκρια would be

TRANSVERSE SECTION OF AN ATHENIAN TRIREME.

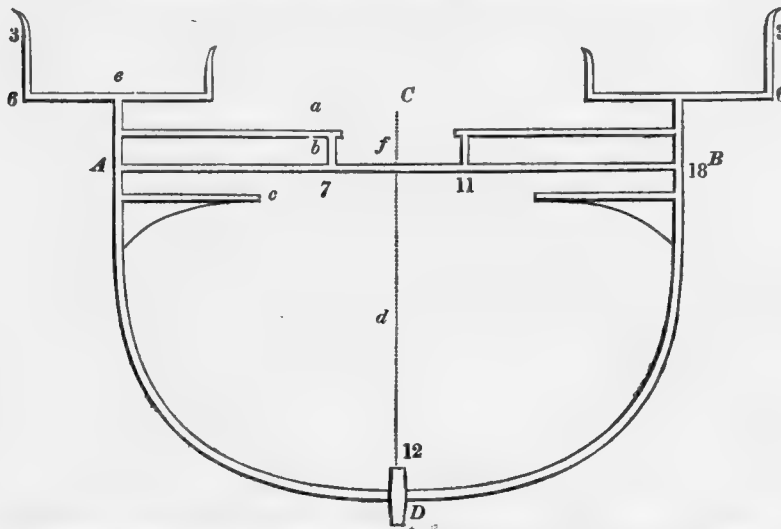

- a. *Thranus*, or long stool, placed on the alternate *zygon*, or supported by the *selis*, and extending 7 feet amidships.
 - b. *Zygon*, or cross-plank, running athwart the vessel at intervals.
 - c. *Thalamitic seat*, 4ft. 6in.
 - d. *Thalamos*, or hold leading to *antlos*.
 - e. Platform for *Epibatæ* running along the *traphex*, and 6 feet wide, with bulwarks of 3 feet.
 - f. *Selis*, or gangway, fore-and-aft, 4 feet wide.
- A—B, (Breadth of beam) = 18 feet. C—D, (Depth) = 12 feet.

an appropriate designation. In larger vessels, however, these ἴκρια would be remanded to the decks fore and aft, the cross-pieces would be separate κληῖδες or ζυγά, to furnish a ready access to the hold; and, in the case of a trireme, both to allow ventilation for the lowest tier of rowers who worked there, and also to permit the officers, who gave them the stroke, to hear the whistle or word of command, to say nothing of the fact that there was no room for a complete deck between them and the second tier of rowers. Still, however, these ζυγά would be σέλματα, or means of walking from stem to stern; for, by the nature of the case, there was no other footing. As then we know that there were ζυγά in a Greek trireme, as the middle tier of rowers were called ζυγῖται, because they sat there (Jul. Poll. i. 87: τὰ μέσα τῆς νεῶς ζυγά, οὗ οἱ ζυγῖται κάθηνται), and as it was necessary that room should be economized, and the length of the upper oars kept at a minimum, we conclude that these middle rowers actually sat upon the *transtra* or cross-planks of the vessel. Böckh is led to the opposite conclusion by the phrase ἑδρας κάπης ζυγίας in one of his Inscriptions (II. 40, p. 286). But this merely means that the trireme in question had one of the ζυγά broken close to the oar-hole, just as the same vessel is stated to have been defective in its τράφηξ or bulwark. And in a subsequent part of the same inscription (p. 291) we have the phrase τῶν ζυγῶν κεπώπηνται πέντε, "only five of the cross-bits are supplied with oars," which implies that the ζυγά were the proper place for one class of the rowers.

II. *The Thalamitæ.*

That the θαλαμίται got their name from having their seats in the θάλαμος (Jul. Poll. i. 87: θάλαμος οὗ οἱ θαλάμοι ἐρέττουσι), and that this meant the hold of the vessel, is quite obvious, and it would generally be supposed that the hold was so called, because, like the women's apartments, the nursery, the store-room, &c. in a house, it was the inner part, the least accessible quarter of the ship. It may however be doubted, whether, in its proper meaning, θάλαμος, like θόλος, did not imply specifically a vaulted chamber. If so, the hold, sloping inwards to the keel, would represent an inverted θάλαμος, just as the bees' cells were called by this name (*Anth. Pal.* ix. 404, 2):

ἄπλαστοι χειρῶν ἀυτοπαγεῖς θαλάμαι,

i. e. "chambers not formed by the hands, but all of a piece." We have a similar inversion in the *laquear* or *lacunar* of the ceiling, which was an inverted pit, bin, tray or trough, and in the word *obba*, which properly meant a drinking-vessel with a sharp point at the bottom, but was also used to designate a cap, with a sharp point at the top. In fact the words "cap" and "cup" might be taken as different forms of the same word denoting inverted uses of the same object. Be this as it may, it is clear that the θαλαμίται sat in the hold, with their feet upon the water-line; and as there was no lower range of cross-bits, they must have had benches projecting from the side of the ship. It is just possible that these benches were technically called θαλάμοι. At least, in the curious story told by Timæus (ap. *Athen.* p. 37) of the young men at Agrigentum who fancied that their house was a trireme at sea, one of them says ὑπὸ τοῦ δέου καταβαλὼν ἑμαυτὸν ὑπὸ τοὺς θαλάμους, ὡς ἔνι μάλιστα κατωτάτω

ἐκείμην, "having flung myself, in my fear, under the θάλαμοι, I lay as low down as possible." The bottom of the hold, however, was also called the ἄντλος, a name given afterwards to the bilge-water which settled there, and to the pump, by which it was bailed out.

III. *The Thranitæ.*

An examination of the name of the θρανῖται or "benchmen" of the highest tier, leads to some very interesting results. The whole of this tier was called the θράνος, because the rowers were seated on benches, which did not reach across the vessel, but rested by means of short legs on the ζυγά beneath, so as to resemble a θρήνυς or foot-stool. It has been supposed that θρήνυς and θράνος are other forms of θρόνος, but this seems very unlikely. It would be more reasonable to connect θρόνος with the root στρο-, and to understand an original form στρόνος, but to recognize in θράνος or θρήνυς the root of θραύω; for the idea conveyed by the latter is that of a fragment or separate piece, the θρόνος being the seat with its cushion, and the θρήνυς the detached ὑποπόδιον. And this view is not affected by the consideration that the θρήνυς in a trireme was really a seat and not a foot-stool. It could only have been high enough to enable the θρανίτης to use the ζυγόν immediately before him as a stretcher, and to carry the handle of his oar clear of the ζυγίτης below and behind him; and, by a proper arrangement of the seats, less than one foot six inches would suffice for this. Now we know that the θρήνυς was seven feet long, even in Homer's time. It was therefore just like a low foot-stool placed on the ζυγόν. Why it was so constructed may easily be shown. If the θρήνυς had run quite across the ship, the ζυγίται and θαλαμίται could not have got to their places without passing over the upper benches, and there would have been no passage fore and aft for the officers of the vessel. It must always be recollected that the trireme was not a three-decker, but a mere galley with three tiers of benches, and till a comparatively late period only partially decked over all. When the deck was introduced, it was carried from the poop to the fore-castle, either so raised in the middle that there was room for a man to walk upright along the ζυγά, or else carried to the same height above the bulwarks on each side, in which case the sides of the bulwark were an open grating for the whole length of the vessel. Originally, however, the ἴκρια were confined to the two ends of the vessel, and in going amidship it was necessary to step down, first to a θρήνυς and then to the ζυγά. In Homer's account of the attack on the Greek ships, which were drawn ashore, with their heads to the sea, it is stated that Ajax, who was their chief defender, passed along the line of quarter-decks, jumping from ship to ship, like a horse-vaulter, and driving off the enemy with a punting pole 22 cubits long; until at last he was obliged to yield to superior numbers, and retired a little way (ἀνεχάζετο τυτθόν) i. e. so as merely to get out of immediate danger, to a bench seven feet long (θρήνυς ἐφ' ἑπταπόδη), and "he left the deck of the equal ship" (λίπε δ' ἴκρια νῆος ἕϊσης); in this lower position he stood watching, and repulsing with his long pole any Trojan who endeavoured to set fire to the vessels (*Il.* xv. 674—731). That the θρήνυς was always seven feet long, in other words, that the war-ship had always the same breadth of beam, appears from the following considerations. In order to give the full advantage of the leverage for the longest oar, it is manifest that the rowers of the upper tier would sit as far as they could

from the side of the vessel. Consequently the passage for the officers, &c. along the ζυγά would be as narrow as possible. Now the minimum breadth for the free and rapid passage of a man up to his knees is two feet. With seven feet then for each of the benches, and two feet at least for the passage between them, we require sixteen feet for the minimum breadth of the trireme, and I am informed by travellers, who have just returned from Athens, and who have measured the slips in the docks of the Piræus, that this was precisely the breadth allowed for a Greek war galley under the water-line. Adding two feet for the breadth between the tops of the ribs, we shall get the means of passing the mast, and the whole beam will be eighteen feet, or, including the projecting gangways for the *epibatæ*, twenty-four feet over all. For the height of the trireme's sides and its draught, we have no authority. I conjecture that it drew about six feet, and that there was about the same depth from the platform of the *Epibatæ* to the water-line. Considering that the trireme was a sea-boat, and that the ports for the oars were large enough to admit of a man's head being thrust through them (Herod. v. 33), and to expose the rowers to missiles from boats rowing along-side (Thucyd. vii. 40), it is extremely unlikely that the lower ports would be less than two feet above the water. And as the oars were not too long to be carried by a single man on a march across the Isthmus (Thucyd. ii. 93) even those of the *thranitæ* must have been less than twenty feet long. The inscriptions mention the length of the supplementary oars only, and these seem to have varied from nine to nine and a half cubits. I have no doubt that the *thranitic* oars were longer than this, and the epithet *δολιχέρητος* which Pindar applies to Ægina (*Ol.* viii. 20), indicates that the length of the working oars in a trireme was as considerable as that of the long spear which was similarly designated (Hom. *Il.* xxi. 155: *δολιχερκής*, *III.* 346, &c.: *δολιχόσκιον ἔγκος*). And this must have been the case if they were pulled with a good leverage. The best result that I can obtain by conjectural measurements gives about fifteen feet for the *thranitic* oars, of which five feet were within and ten without the ship; twelve feet for the *zygitic* oars, and nine or ten for the *thalamitic*. That there was a great difference between the length of the *thranitic* oars and those of the lower tiers is implied by what Thucydides says (vi. 31), as illustrated by the Scholiast: οἱ δὲ θρανῖται μετὰ μακροτέρων κωπῶν ἐρέττοντες πλείονα κόπον ἔχουσι τῶν ἄλλων· διὰ τοῦτο τούτοις μόνοις ἐπίδοσις ἐποιοῦντο οἱ τριηράρχαι οὐχὶ δὲ πᾶσι τοῖς ἐρέταις. It appears that all the oars were longest at the middle of the ship. For though the oar-blades touched the water in the same line, the trireme was broader in the middle, the *thranus* was longer there, and the rower sat farther from the side. This is clear from what Galen says, when he compares the oars to the fingers of the human hand when clenched (*de usu partium corporis humani*, I. 24, Vol. III. p. 85, Kuhn): καθάπερ οἶμαι κὰν ταῖς τριήρεσι τὰ πείρατα τῶν κωπῶν εἰς ἴσον ἐξικνεῖται καὶ τοι γ' οὖν οὐκ ἰσῶν ἀπασῶν οὐσῶν, καὶ γὰρ οὖν κάκει τὰς μέσας μεγίστας. Aristotle makes a similar comparison (*de partibus animalium*, iv. 10, § 27: ὁ μέσος [δάκτυλος] μακρός, ὥσπερ κώπη μεσόνης); and he enters more fully into the subject in his *Mechanica*, c. 4, where he answers the question: διὰ τί οἱ μεσόνοι μάλιστα τὴν ναῦν κινοῦσιν; by referring to the principle of the lever—though he takes the water as the weight and the rowlock as the fulcrum—and having asserted the principle, he says: ἐν μέσῃ δὲ τῇ νηὶ πλείστον τῆς κώπης ἐντός ἐστίν· καὶ γὰρ ἡ ναῦς ταύτη εὐρυτάτη ἐστίν, ὥστε πλείον ἐπ' ἀμφοτέρα ἐνδέχσθαι μέρος τῆς κώπης ἐκατέρω

τοίχου ἐντός εἶναι τῆς νεώς,—and at the end he adds: διὰ τοῦτο οἱ μεσόνοι μάλιστα κινούσιν· μέγιστον γὰρ ἐν μέσῃ νηὶ τὸ ἀπὸ τοῦ σκαλοῦ τῆς κόπης τὸ ἐντός ἐστίν. To a strange misunderstanding of these statements respecting the oars at the middle of the trireme combined with the remark of the Scholiast on Aristophanes (above, p. 4) that each *xygite* sat between the *thranite* and *thalamite* immediately next to him, and the words of Pollux (above, p. 7) that the ζυγά were τὰ μέσα τῆς νεώς (i. e. considering the three tiers as horizontal lines), we owe the perplexing theory, first started, I believe, by Schneider in his Lexicon, s. v. μεσόνοι, that the *xygites*, as a body, sat in the middle of the ship, and that their oars were the longest! The inferior position of the *thalamites* as compared with the other rowers is coarsely intimated by Aristophanes (*Ranæ* 1074), and implied in the fact that they were left on board when the rest of the crew disembarked to serve on shore (Thucyd. iv. 32). And from what Aristophanes says, in his description of the bustle in the dockyard which attended a sudden preparation for sea, I am disposed to infer that the first step in the equipment of a trireme was to provide it with oars for the *thalamites*, who navigated the vessel provisionally, and until it got its full complement or fighting crew; for, in immediate connexion with making the spars into oars (κωπέων πλατουμένων), he speaks of fitting the lowest oars with thongs (θαλαμιῶν τροπουμένων, *Acharn.* 552, 553). The interval between two oar-ports on the same tier was two cubits (Vitruv. i. 2), or three feet six inches, and as the *thranite* sat before (i. e. nearer to the stern than) the *zygite*, and he than the *thalamite*, it is not difficult to conceive an arrangement by which the bodies of the lower rowers would have free play as they bent forward to their work. The measurement, which I have proposed (p. 6), leaves ample room for the *thalamites* to pull under the platform for the *epibatæ*. It is not impossible that the *thranus* rested on the *selis*, so that there were *xyga* or cross planks only where the *zygites* sat. This seems to be suggested by the explanation in Julius Pollux (i. 87): τὸ δὲ περὶ τὸ κατάστρωμα θρᾶνος, οὗ οἱ θραῦνται, for the only κατάστρωμα was the gangway.

I will now apply these considerations to the removal of some difficulties which have been very troublesome to editors.

(a) The conjecture that the interval between the ends of the upper benches or *thranos* was intended to leave a passage along the σέλματα or ζυγά is supported by the fact that the special name for this passage was *σελῖς*, a name also given to the spaces between the benches in the theatre. Hesychius defines the *σελίδας* as τὰ μεταξὺ διαφράγματα τῶν διαστημάτων τῆς νεώς, “the middle partitions of the passages in the ship.” And that this was the primary meaning is clear from the glosses in Eustathius and Julius Pollux, which connect *σελῖς* with σέλμα. In later times *σελῖς* was commonly used to denote the blank space between two columns in a written page. When Phrynichus says (Bekk. *Anecd.* 62, 27): *σελῖς βιβλίου· λέγεται δὲ καὶ σελῖς θεάτρου*, like a grammarian, he confuses between the primary and the secondary meaning. The application of this term to the intercolumnal space in a manuscript, and hence to the page of a book in general, is due to the resemblance between the *κερκίδες* of the theatre, which were divided by the *σελίδες*, and the lines of writing divided by the intervening space of blank paper; and the corridors of the theatre again were called *σελίδες*, because they were flanked on each side by seated spectators, just as the *σελίδες* in the trireme

passed between rowers seated below one another. And hence we derive the explanation of the passage in Aristophanes (*Equites* 546), which has been found unintelligible:

αἶρεσθ' αὐτῶ πολὺ τὸ ρόθιον, παραπέμψατ' ἐφ' ἑνδεκα κώπαις
θόρυβον χρηστὸν ληναίτην—

“raise for him a splash of applause in good measure, and waft him a noble Lenæan cheer with eleven oars.” It seems that there were eleven tiers of seats between each diazoma of the Theatre at Athens, the diazoma itself being counted as the twelfth row. Accordingly, each wedge would suggest the idea of eleven benches of rowers, and the applause, which the chorus demands, would come like the splash of eleven oars striking the water at once.

(b) As the *σελίς* was the only uninterrupted thoroughfare by which the officers could pass to and fro to give their orders and keep the men to their work, we get at last the long sought explanation of a passage in Æschylus, which all the commentators have failed to elucidate. In the course of the altercations between Ægisthus and the chorus at the end of the *Agamemnon*, the usurper is made to address the senators as follows (v. 1588):

σὺ ταῦτα φωνεῖς νερτέρῃα προσήμενος
κώπη, κρατούντων τῶν ἐπὶ ζυγῶ δορός;

“These words from thee, that sittest at the oar
Below, while rulers on the cross-bits walk?”

Here the editors are quite at sea. They cannot understand why the *ζυγῖται* should be described as the *κρατοῦντες* instead of the *θρανῖται*. Dr Blomfield went so far, in his struggle to get out of the difficulty, as to suppose that the old men of the Chorus were the *θαλάμιοι*, Ægisthus and Clytæmnestra the *ζυγῖται*, and the murdered Agamemnon the *θρανίτης*! Paley is satisfied with saying, that the third tier was as inferior to the second, as the second was to the first, “*quare satis recte se habet comparatio.*” And Klausen fancies he has unravelled the perplexity by supposing that Æschylus is speaking of a bireme, being quite ignorant of the fact, that if biremes had been used at Athens, the upper tier of rowers would still have been *θρανῖται*!! The fact is that all these commentators have overlooked a refinement of Greek Syntax. Æschylus, who was as well acquainted with sea-life as any of the men that pulled at Salamis, has been careful to introduce the participle *προσήμενος* in speaking of the rower, while by writing *ἐπὶ ζυγῶ* instead of *ἐπὶ ζυγῶν*, he expressly tells us that the *κρατοῦντες* were not seated on the *ζυγά*, but had their feet upon them. Every Greek scholar is aware that when we wish to say that a man is seated with his legs hanging from his seat, whether it be on a chair, a rowing-bench, or on horse-back, we use *ἐπὶ* with the genitive; but *ἐπὶ* with the dative, when we wish to say that the whole man is upon that which serves as his footing. If the officers had seats they were placed upon the *ζυγά*, and were much higher than the stools of the *θρανῖται*, so that even when seated, the *κρατοῦντες*, or officers, might speak of the rowers of the highest tier as *νερτέρῃα προσημένους κώπη*. Their seats then being placed on the *ζυγά*, they might be said either *καθῆσθαι* or *ἑστηκέναι ἐπὶ ζυγοῖς*, because their feet rested on them; but the *ζυγῖται* could only be said *καθῆσθαι ἐπὶ ζυγῶν*. Hence we have in Eurip. *Phœniss.* 74: *ἐπεὶ δ' ἐπὶ ζυγοῖς καθέζετ' ἀρχῆς*, and Eustathius tells us that the

Homeric epithet ὑψίζυγος is derived from the high seat of the pilot in a ship (p. 131, 18): καὶ τοῦτο δὲ ἀπὸ κυβερνητικῆς μετήνεκται καταστάσεως. For the same reason Æschylus speaks of the Gods as σέλημα σεμνὸν ἡμένων (*Agam.* 176).

(c) Another difficult passage in the same play furnishes an illustration of the fact that the middle part of the σέλιματα or ζυγά, in an old Greek vessel, belonged to the officers and supernumeraries. In v. 1413 it is said of Cassandra, who came with Agamemnon from Troy, that she was ναυτίλων σελμάτων ἰστοτριβῆς, where some read ἰσοτριβῆς. The allusion to Chryseis a line or two before makes it probable that Æschylus had in his recollection the lines in the *Iliad*, where Agamemnon says that old age shall find her: ἰστὸν ἐποιχομένην καὶ ἐμὸν λέχος ἀντιώσαν. Here it is implied that the σέλιματα were her only *gynæceum*, just as Persius says (v. 146): “tun’ mare transsilies? tibi torta cannabe fulto, cœna sit *in transtro*?” Or if ἰστός has its nautical meaning, it will imply that the captain’s quarters were amidships near the mast. But to this it may be objected with reason that, at all events in later times, the captain or admiral occupied a pavilion or round-house on the poop; Jul. Poll. i. 87: ἐκεί που καὶ σκῆνη ὀνομάζεται τὸ πηγνύμενον στρατηγῶ ἢ τριηράρχῳ. And Æschylus himself describes the sovereign of a state as a pilot or captain who keeps sleepless watch at the helm on the quarter-deck of the city (*Sept c. Theb.* 2, 3: ὅστις φυλάσσει πρᾶγος ἐν πρύμνῃ πόλεως οἶακα νωμῶν, βλέφαρα μὴ κοιμῶν ὕπνῳ).

(d) To the practice of moving fore and aft along these cross-planks with frequent intervals, at least where the rowers sat, even if the *selis* was planked, I also refer the proverbial expression of warning, that “we must take care not to step into the bilge-water, or put our foot into the hold” (εἰς ἄντλον ἐμβῆσαι πόδα, Eurip. *Hercul.* 168). It is clear, from this mode of describing it, that the caution referred to some risk of common occurrence. Mr Haliburton connects the corresponding American phrase of “putting your foot into it” with an incident in the backwoods, where a bear grapples with a saw-mill, and is bisected accordingly. Some risk not much less formidable is implied in the Greek expression. When Æschylus says (*Choeph.* 695): ἔξω κομίζων ὀλεθρίου πηλοῦ πόδα, he refers to an escape from serious danger, and not to the mere avoidance of dirt. So this phrase cannot apply to the fear of getting one’s feet wet with bilge-water, or with dirty water in general, but must mean that there was a constant risk of tumbling between the ζυγά, to the very bottom of the ship, if those who walked across the planks did not attend to their feet; and that this often happened with serious consequences to the sailors, officers, and passengers in a trireme.

I submit these observations in the hope that they will tend to clear up some obscurities in Greek history and antiquities, and, at all events, reconcile the language of the best authorities with a probable theory respecting the structure and management of the swift war-boat which dashed through the water and wheeled round at the command of some sea-captain like Phormio, or, as the Greek poet says, sped across the main, keeping pace with the hundred feet of the Nereids (*Soph. Œd. Col.* 720 sqq.).

V. *Of the Platonic Theory of Ideas.* By W. WHEWELL, D.D. *Master of Trinity College, Cambridge.*

[Read *November 10, 1856.*]

THOUGH Plato has, in recent times, had many readers and admirers among our English scholars, there has been an air of unreality and inconsistency about the commendation which most of these professed adherents have given to his doctrines. This appears to be no captious criticism, for instance, when those who speak of him as immeasurably superior in argument to his opponents, do not venture to produce his arguments in a definite form as able to bear the tug of modern controversy;—when they use his own Greek phrases as essential to the exposition of his doctrines, and speak as if these phrases could not be adequately rendered in English;—and when they assent to those among the systems of philosophy of modern times which are the most clearly opposed to the system of Plato. It seems not unreasonable to require, on the contrary, that if Plato is to supply a philosophy for us, it must be a philosophy which can be expressed in our own language;—that his system, if we hold it to be well founded, shall compel us to deny the opposite systems, modern as well as ancient;—and that, so far as we hold Plato's doctrines to be satisfactorily established, we should be able to produce the arguments for them, and to refute the arguments against them. These seem reasonable requirements of the adherents of *any* philosophy, and therefore, of Plato's.

I regard it as a fortunate circumstance, that we have recently had presented to us an exposition of Plato's philosophy which does conform to those reasonable conditions; and we may discuss this exposition with the less reserve, since its accomplished author, though belonging to this generation, is no longer alive. I refer to the *Lectures* on the History of Ancient Philosophy, by the late Professor Butler of Dublin. In these Lectures, we find an account of the Platonic Philosophy which shews that the writer had considered it as, what it is, an attempt to solve large problems, which in all ages force themselves upon the notice of thoughtful men. In Lectures VIII. and X., of the Second Series, especially, we have a statement of the Platonic Theory of Ideas, which may be made a convenient starting point for such remarks as I wish at present to make. I will transcribe this account; omitting, as I do so, the expressions which Professor Butler uses, in order to present the theory, not as a dogmatical assertion, but as a view, at least not extravagant. For this purpose, he says, of the successive portions of the theory, that one is "not too absurd to be maintained;" that another is "not very extravagant either;" that a third is "surely allowable;" that a fourth

presents "no incredible account" of the subject; that a fifth is "no preposterous notion in substance, and no unwarrantable form of phrase." Divested of these modest formulæ, his account is as follows: [Vol. II. p. 117.]

"Man's soul is made to contain not merely a consistent scheme of its own notions, but a direct apprehension of *real and eternal laws beyond it*. These real and eternal laws are things *intelligible*, and not things sensible.

"These laws impressed upon creation by its Creator, and apprehended by man, are something distinct equally from the Creator and from man, and the whole mass of them may fairly be termed the World of Things Intelligible.

"Further, there are qualities in the supreme and ultimate Cause of all, which are manifested in His creation, and not merely manifested, but, in a manner—after being brought out of his superessential nature into the stage of being [which is] below him, but next to him—are then by the causative act of creation deposited in things, differencing them one from the other, so that the things partake of them (*μετέχουσι*), communicate with them (*κοινωνοῦσι*).

"The intelligence of man, excited to reflection by the impressions of these objects thus (though themselves transitory) participant of a divine quality, may rise to higher conceptions of the perfections thus faintly exhibited; and inasmuch as these perfections are unquestionably *real* existences, and *known* to be such in the very act of contemplation,—this may be regarded as a direct intellectual apperception of them,—a Union of the Reason with the Ideas in that sphere of being which is common to both.

"Finally, the Reason, in proportion as it learns to contemplate the Perfect and Eternal, *desires* the enjoyment of such contemplations in a more consummate degree, and cannot be fully satisfied, except in the actual fruition of the Perfect itself.

"These suppositions, taken together, constitute the Theory of Ideas."

In remarking upon the theory thus presented, I shall abstain from any discussion of the theological part of it, as a subject which would probably be considered as unsuited to the meetings of this Society, even in its most purely philosophical form. But I conceive that it will not be inconvenient, if it be not wearisome, to discuss the Theory of Ideas as an attempt to explain the existence of real knowledge; which Prof. Butler very rightly considers as the necessary aim of this and cognate systems of philosophy*.

I conceive, then, that one of the primary objects of Plato's Theory of Ideas is, to explain the existence of real knowledge, that is, of demonstrated knowledge, such as the propositions of geometry offer to us. In this view, the Theory of Ideas is one attempt to solve a problem, much discussed in our times, What is the ground of geometrical truth? I do not mean that this is the whole object of the Theory, or the highest of its claims. As I have said, I omit its theological bearings; and I am aware that there are passages in the Platonic Dialogues, in which the Ideas which enter into the apprehension and demonstration of geometrical truths are spoken of as subordinate to Ideas which have a theological aspect. But I have no doubt that one of the main motives to the construction of the Theory of Ideas

* P. 116. "No amount of human knowledge can be adequate which does not solve the phenomena of these absolute certainties."

was, the desire of solving the Problem, "How is it possible that man should apprehend necessary and eternal truths?" That the truths are necessary, makes them eternal, for they do not depend on time; and that they are eternal, gives them at once a theological bearing.

That Plato, in attempting to explain the nature and possibility of real knowledge, had in his mind geometrical truths, as examples of such knowledge, is, I think, evident from the general purport of his discourses on such subjects. The advance of Greek geometry into a conspicuous position, at the time when the Heraclitean sect were proving that nothing could be proved and nothing could be known, naturally suggested mathematical truth as the refutation of the skepticism of mere sensation. On the one side it was said, we can know nothing except by our sensations; and that which we observe with our senses is constantly changing; or at any rate, may change at any moment. On the other hand it was said, we *do* know geometrical truths, and as truly as we know them, we know that they cannot change. Plato was quite alive to the lesson, and to the importance of this kind of truths. In the *Meno* and in the *Phædo* he refers to them, as illustrating the nature of the human mind: in the *Republic* and the *Timæus* he again speaks of truths which far transcend anything which the senses can teach, or even adequately exemplify. The senses, he argues in the *Theætetus*, cannot give us the knowledge which we have; the source of it must therefore be in the mind itself; in the *Ideas* which it possesses. The impressions of sense are constantly varying, and incapable of giving any certainty: but the Ideas on which real truth depends are constant and invariable, and the certainty which arises from these is firm and indestructible. Ideas are the permanent, perfect objects, with which the mind deals when it contemplates necessary and eternal truths. They belong to a region superior to the material world, the world of sense. They are the objects which make up the furniture of the Intelligible World: with which the Reason deals, as the Senses deal each with its appropriate Sensation.

But, it will naturally be asked, what is the Relation of Ideas to the Objects of Sense? Some connexion, or relation, it is plain, there must be. The objects of sense can suggest, and can illustrate real truths. Though these truths of geometry cannot be proved, cannot even be exactly exemplified, by drawing diagrams, yet diagrams are of use in helping ordinary minds to see the proof; and to all minds, may represent and illustrate it. And though our conclusions with regard to objects of sense may be insecure and imperfect, they have some shew of truth, and therefore some resemblance to truth. What does this arise from? How is it explained, if there is no truth except concerning Ideas?

To this the Platonist replied, that the phenomena which present themselves to the senses partake, in a certain manner, of Ideas, and thus include so much of the nature of Ideas, that they include also an element of Truth. The geometrical diagram of Triangles and Squares which is drawn in the sand of the floor of the Gymnasium, partakes of the nature of the true Ideal Triangles and Squares, so that it presents an imitation and suggestion of the truths which are true of them. The real triangles and squares are in the mind; they are, as we have said, objects, not in the Visible, but in the Intelligible World. But the Visible Triangles and Squares make us call to mind the Intelligible; and thus the objects of sense suggest, and, in a way, exemplify the eternal truths.

This I conceive to be the simplest and directest ground of two primary parts of the Theory of Ideas;—The Eternal Ideas constituting an Intelligible World; and the Participation in these Ideas ascribed to the objects of the world of sense. And it is plain that so far, the Theory meets what, I conceive, was its primary purpose; it answers the questions, How can we have certain knowledge, though we cannot get it from Sense? and, How can we have knowledge, at least apparent, though imperfect, about the world of sense?

But is this the ground on which Plato himself rests the truth of his Theory of Ideas? As I have said, I have no doubt that these were the questions which suggested the Theory; and it is perpetually applied in such a manner as to shew that it was held by Plato in this sense. But his applications of the Theory refer very often to another part of it;—to the Ideas, not of Triangles and Squares, of space and its affections; but to the Ideas of Relations—as the Relations of Like and Unlike, Greater and Less; or to things quite different from the things of which geometry treats, for instance, to Tables and Chairs, and other matters, with regard to which no demonstration is possible, and no general truth (still less necessary and eternal truth) capable of being asserted.

I conceive that the Theory of Ideas, thus asserted and thus supported, stands upon very much weaker ground than it does, when it is asserted concerning the objects of thought, about which necessary and demonstrable truths are attainable. And in order to devise arguments against *this* part of the Theory, and to trace the contradictions to which it leads, we have no occasion to task our own ingenuity. We find it done to our hands, not only in Aristotle, the open opponent of the Theory of Ideas, but in works which stand among the Platonic Dialogues themselves. And I wish especially to point out some of the arguments against the Ideal Theory, which are given in one of the most noted of the Platonic Dialogues, the *Parmenides*.

The *Parmenides* contains a narrative of a Dialogue held between Parmenides and Zeno, the Eleatic Philosophers, on the one side, and Socrates, along with several other persons, on the other. It may be regarded as divided into two main portions; the first, in which the Theory of Ideas is attacked by Parmenides, and defended by Socrates; the second, in which Parmenides discusses, at length, the Eleatic doctrine that *All things are One*. It is the former part, the discussion of the Theory of Ideas, to which I especially wish to direct attention at present: and in the first place, to that extension of the Theory of Ideas, to things of which no general truth is possible; such as I have mentioned, tables and chairs. Plato often speaks of a Table, by way of example, as a thing of which there must be an Idea, not taken from any special Table or assemblage of Tables; but an Ideal Table, such that all Tables are Tables by participating in the nature of this Idea. Now the question is, whether there is any force, or indeed any sense, in this assumption; and this question is discussed in the *Parmenides*. Socrates is there represented as very confident in the existence of Ideas of the highest and largest kind, the Just, the Fair, the Good, and the like. Parmenides asks him how far he follows his theory. Is there, he asks, an Idea of Man, which is distinct from us men? an Idea of Fire? of Water? “In truth,” replies Socrates, “I have often hesitated, Parmenides, about these, whether we are to allow such Ideas.” When Plato had proceeded to teach that there is an Idea of a Table, of course he could not reject

such Ideas as Man, and Fire, and Water. Parmenides, proceeding in the same line, pushes him further still. "Do you doubt," says he, "whether there are Ideas of things apparently worthless and vile? Is there an Idea of a Hair? of Mud? of Filth?" Socrates has not the courage to accept such an extension of the theory. He says, "By no means. These are not Ideas. These are nothing more than just what we see them. I have often been perplexed what to think on this subject. But after standing to this a while, I have fled the thought, for fear of falling into an unfathomable abyss of absurdities." On this, Parmenides rebukes him for his want of consistency. "Ah Socrates," he says, "you are yet young; and philosophy has not yet taken possession of you as I think she will one day do—when you will have learned to find nothing despicable in any of these things. But now your youth inclines you to regard the opinions of men." It is indeed plain, that if we are to assume an Idea of a Chair or a Table, we can find no boundary line which will exclude Ideas of everything for which we have a name, however worthless or offensive. And this is an argument against the assumption of *such* Ideas, which will convince most persons of the groundlessness of the assumption:—the more so, as *for* the assumption of such Ideas, it does not appear that Plato offers any argument whatever; nor does this assumption solve any problem, or remove any difficulty*. Parmenides, then, had reason to say that consistency required Socrates, if he assumed any such Ideas, to assume all. And I conceive his reply to be to this effect; and to be thus a *reductio ad absurdum* of the Theory of Ideas in this sense. According to the opinions of those who see in the *Parmenides* an exposition of Platonic doctrines, I believe that Parmenides is conceived in this passage, to suggest to Socrates what is necessary for the completion of the Theory of Ideas. But upon either supposition, I wish especially to draw the attention of my readers to the position of superiority in the Dialogue in which Parmenides is here placed with regard to Socrates.

Parmenides then proceeds to propound to Socrates difficulties with regard to the Ideal Theory, in another of its aspects;—namely, when it assumes Ideas of Relations of things; and here also, I wish especially to have it considered how far the answers of Socrates to these objections are really satisfactory and conclusive.

"Tell me," says he (§ 10, Bekker), "You conceive that there are certain Ideas, and that things partaking of these Ideas, are called by the corresponding names;—an Idea of *Likeness*, things partaking of which are called *Like*;—of *Greatness*, whence they are *Great*: of *Beauty*, whence they are *Beautiful*?" Socrates assents, naturally: this being the simple and universal statement of the Theory, in this case. But then comes one of the real difficulties of the Theory. Since the special things participate of the General Idea, has each got the whole of the Idea, which is, of course, One; or has each a part of the Idea? "For," says Parmenides, "can there be any other way of participation than these two?" Socrates replies by a similitude: "The Idea, though One, may be wholly in each object, as the Day, one and the same, is wholly in each place." The physical illustration, Parmenides damages by making it more physical still. "You are ingenious, Socrates," he says, (§ 11) "in making the same thing be in

* Prof. Butler, Lect. ix. Second Series, p. 136, appears to think that Plato had sufficient grounds (of a theological kind) for the assumption of such Ideas; but I see no trace of them.

many places at the same time. If you had a number of persons wrapped up in a sail or web, would you say that each of them had the whole of it? Is not the case similar?" Socrates cannot deny that it is. "But in this case, each person has only a part of the whole; and thus your Ideas are partible." To this, Socrates is represented as assenting in the briefest possible phrase; and thus, here again, as I conceive, Parmenides retains his superiority over Socrates in the Dialogue.

There are many other arguments urged against the Ideal Theory of Parmenides. The next is a consequence of this partibility of Ideas, thus supposed to be proved, and is ingenious enough. It is this:

"If the Idea of Greatness be distributed among things that are Great, so that each has a part of it, each separate thing will be Great in virtue of a part of Greatness which is less than Greatness itself. Is not this absurd?" Socrates submissively allows that it is.

And the same argument is applied in the case of the Idea of Equality.

"If each of several things have a part of the Idea of Equality, it will be Equal to something, in virtue of something which is less than Equality."

And in the same way with regard to the Idea of Smallness.

"If each thing be small by having a part of the Idea of Smallness, Smallness itself will be greater than the small thing, since that is a part of itself."

These ingenious results of the partibility of Ideas remind us of the ingenuity shewn in the Greek geometry, especially the Fifth Book of Euclid. They are represented as not resisted by Socrates (§ 12): "In what way, Socrates, can things participate in Ideas, if they cannot do so either integrally or partibly?" "By my troth," says Socrates, "it does not seem easy to tell." Parmenides, who completely takes the conduct of the Dialogue, then turns to another part of the subject and propounds other arguments. "What do you say to this?" he asks.

"There is an Ideal Greatness, and there are many things, separate from it, and Great by virtue of it. But now if you look at Greatness and the Great things together, since they are all Great, they must be Great in virtue of some higher Idea of Greatness which includes both. And thus you have a Second Idea of Greatness; and in like manner you will have a third, and so on indefinitely."

This also, as an argument against the separate existence of Ideas, Socrates is represented as unable to answer. He replies interrogatively:

"Why, Parmenides, is not each of these Ideas a Thought, which, by its nature, cannot exist in anything except in the Mind? In that case your consequences would not follow."

This is an answer which changes the course of the reasoning: but still, not much to the advantage of the Ideal Theory. Parmenides is still ready with very perplexing arguments. (§ 13:)

"The Idea, then," he says, "are Thoughts. They must be Thoughts of something. They are Thoughts of something, then, which exists in all the special things; some one thing which the Thought perceives in all the special things; and this one Thought thus involved in all, is the *Idea*. But then, if the special things, as you say, participate in the Idea, they participate in the Thought; and thus, all objects are made up of Thoughts, and all things think; or else, there are thoughts in things which do not think."

This argument drives Socrates from the position that Ideas are Thoughts, and he moves to another, that they are Paradigms, Exemplars of the qualities of things, to which the things themselves are like, and their being thus like, is their participating in the Idea. But here too, he has no better success. Parmenides argues thus:

“If the Object be like the Idea, the Idea must be like the Object. And since the Object and the Idea are like, they must, according to your doctrine, participate in the Idea of Likeness. And thus you have one Idea participating in another Idea, and so on in infinitum.” Socrates is obliged to allow that this demolishes the notion of objects partaking in their Ideas by likeness; and that he must seek some other way. “You see then, O Socrates,” says Parmenides, “what difficulties follow, if any one asserts the independent existence of Ideas!” Socrates allows that this is true. “And yet,” says Parmenides, “you do not half perceive the difficulties which follow from this doctrine of Ideas.” Socrates expresses a wish to know to what Parmenides refers; and the aged sage replies by explaining that if Ideas exist independently of us, we can never know anything about them: and that even the Gods could not know anything about man. This argument, though somewhat obscure, is evidently stated with perfect earnestness, and Socrates is represented as giving his assent to it. “And yet,” says Parmenides, (end of § 18) “if any one gives up entirely the doctrine of Ideas, how is any reasoning possible?”

All the way through this discussion, Parmenides appears as vastly superior to Socrates; as seeing completely the tendency of every line of reasoning, while Socrates is driven blindly from one position to another; and as kindly and graciously advising a young man respecting the proper aims of his philosophical career; as well as clearly pointing out the consequences of his assumptions. Nothing can be more complete than the higher position assigned to Parmenides in the Dialogue.

This has not been overlooked by the Editors and Commentators of Plato. To take for example one of the latest; in Steinhart's Introduction to Hieronymus Müller's translation of *Parmenides* (Leipzig, 1852), p. 261, he says: “It strikes us, at first, as strange, that Plato here seems to come forward as the assailant of his own doctrine of Ideas. For the difficulties which he makes Parmenides propound against that doctrine are by no means sophistical or superficial, but substantial and to the point. Moreover there is among all these objections, which are partly derived from the Megarics, scarce one which does not appear again in the penetrating and comprehensive argumentations of Aristotle against the Platonic Doctrine of Ideas.”

Of course, both this writer and other commentators on Plato offer something as a solution of this difficulty. But though these explanations are subtle and ingenious, they appear to leave no satisfactory or permanent impression on the mind. I must avow that, to me, they appear insufficient and empty; and I cannot help believing that the solution is of a more simple and direct kind. It may seem bold to maintain an opinion different from that of so many eminent scholars; but I think that the solution which I offer, will derive confirmation from a consideration of the whole Dialogue; and therefore I shall venture to propound it in a distinct and positive form. It is this:

I conceive that the *Parmenides* is not a Platonic Dialogue at all; but Antiplatonic, or more properly, *Eleatic*: written, not by Plato, in order to explain and prove his Theory of

Ideas, but by some one, probably an admirer of Parmenides and Zeno, in order to shew how strong were his master's arguments against the Platonists, and how weak their objections to the Eleatic doctrine.

I conceive that this view throws an especial light on every part of the Dialogue, as a brief survey of it will shew. Parmenides and Zeno come to Athens to the Panathenaic festival: Parmenides already an old man, with a silver head, dignified and benevolent in his appearance, looking five and sixty years old: Zeno about forty, tall and handsome. They are the guests of Pythodorus, outside the Wall, in the Ceramicus; and there they are visited by Socrates, then young, and others who wish to hear the written discourses of Zeno. These discourses are explanations of the philosophy of Parmenides, which he had delivered in verse.

Socrates is represented as shewing, from the first, a disposition to criticize Zeno's dissertation very closely; and without any prelude or preparation, he applies the Doctrine of Ideas to refute the Eleatic Doctrine that All Things are One. (§ 3.) When he had heard to the end, he begged to have the first Proposition of the First Book read again. And then: "How is it, O Zeno, that you say, That if the Things which exist are Many, and not One, they must be at the same time like and unlike? Is this your argument? Or do I misunderstand you?" "No," says Zeno, "you understand quite rightly." Socrates then turns to Parmenides, and says, somewhat rudely, as it seems, "Zeno is a great friend of yours, Parmenides: he shews his friendship not only in other ways, but also in what he writes. For he says the same things which you say, though he pretends that he does not. You say, in your poems, that All Things are One, and give striking proofs: he says that existences are not many, and he gives many and good proofs. You seem to soar above us, but you do not really differ." Zeno takes this sally good-humouredly, and tells him that he pursues the scent with the keenness of a Laconian hound. "But," says he (§ 6), "there really is less of ostentation in my writing than you think. My Essay was merely written as a defence of Parmenides long ago, when I was young; and is not a piece of display composed now that I am older. And it was stolen from me by some one; so that I had no choice about publishing it."

Here we have, as I conceive, Socrates already represented as placed in a disadvantageous position, by his abruptness, rude allusions, and readiness to put bad interpretations on what is done. For this, Zeno's gentle pleasantry is a rebuke. Socrates, however, forthwith rushes into the argument; arguing, as I have said, for his own Theory.

"Tell me," he says, "do you not think there is an Idea of Likeness, and an Idea of Unlikeness? And that everything partakes of these Ideas? The things which partake of Unlikeness are unlike. If all things partake of both Ideas, they are both like and unlike; and where is the wonder? (§ 7.) If you could shew that Likeness itself was Unlikeness, it would be a prodigy; but if things which partake of these opposites, have both the opposite qualities, it appears to me, Zeno, to involve no absurdity."

"So if Oneness itself were to be shewn to be Maniness" (I hope I may use this word, rather than multiplicity) "I should be surprized; but if any one say that *I* am at the same time one and many, where is the wonder? For I partake of maniness: my right side is different from my left side, my upper from my under parts. But I also partake of Oneness,

for I am here One of us seven. So that both are true. And so if any one say that stocks and stones, and the like, are both one and many,—not saying that Oneness is Maniness, nor Maniness Oneness, he says nothing wonderful: he says what all will allow. (§ 8.) If then, as I said before, any one should take separately the Ideas or Essence of Things, as Likeness and Unlikeness, Maniness and Oneness, Rest and Motion, and the like, and then should shew that these can mix and separate again, I should be wonderfully surprised, O Zeno: for I reckon that I have tolerably well made myself master of these subjects*. I should be much more surprised if any one could shew me this contradiction involved in the Ideas themselves; in the object of the Reason, as well as in Visible objects.”

It may be remarked that Socrates delivers all this argumentation with the repetitions which it involves, and the vehemence of its manner, without waiting for a reply to any of his interrogations; instead of making every step the result of a concession of his opponent, as is the case in the Dialogues where he is represented as triumphant. Every reader of Plato will recollect also that in those Dialogues, the triumph of temper on the part of Socrates is represented as still more remarkable than the triumph of argument. No vehemence or rudeness on the part of his adversaries prevents his calmly following his reasoning; and he parries coarseness by compliment. Now in this Dialogue, it is remarkable that this kind of triumph is given to the adversaries of Socrates. “When Socrates had thus delivered himself,” says Pythodorus, the narrator of the conversation, “we thought that Parmenides and Zeno would both be angry. But it was not so. They bestowed entire attention upon him, and often looked at each other, and smiled, as in admiration of Socrates. And when he had ended, Parmenides said: ‘O Socrates, what an admirable person you are, for the earnestness with which you reason! Tell me then, Do you then believe the doctrine to which you have been referring;—that there are certain Ideas, existing independent of Things; and that there are, separate from the Ideas, Things which partake of them? And do you think that there is an Idea of Likeness besides the likeness which we have; and a Oneness and a Maniness, and the like? And an Idea of the Right, and the Good, and the Fair, and of other such qualities?’” Socrates says that he does hold this; Parmenides then asks him, how far he carries this doctrine of Ideas, and propounds to him the difficulties which I have already stated; and when Socrates is unable to answer him, lets him off in the kind but patronizing way which I have already described.

To me, comparing this with the intellectual and moral attitude of Socrates in the most dramatic of the other Platonic Dialogues, it is inconceivable, that this representation of Socrates should be Plato’s. It is just what Zeno would have written, if he had wished to bestow upon his master Parmenides the calm dignity and irresistible argument which Plato assigns to Socrates. And this character is kept up to the end of the Dialogue. When Socrates (§ 19) has acknowledged that he is at a loss which way to turn for his philosophy, Parmenides undertakes, though with kind words, to explain to him by what fundamental error in the course of his speculative habits he has been misled. He says; “You try to make a complete

* I am aware that this translation is different from the common translation. It appears to me to be consistent with the habit of the Greek language. It slightly leans in favour

of my view; but I do not conceive that the argument would be perceptibly weaker, if the common interpretation were adopted.

Theory of Ideas, before you have gone through a proper intellectual discipline. The impulse which urges you to such speculations is admirable—is divine. But you must exercise yourself in reasoning which many think trifling, while you are yet young; if you do not, the truth will elude your grasp.” Socrates asks submissively what is the course of such discipline: Parmenides replies, “The course pointed out by Zeno, as you have heard.” And then, gives him some instructions in what manner he is to test any proposed Theory. Socrates is frightened at the laboriousness and obscurity of the process. He says, “You tell me, Parmenides, of an overwhelming course of study; and I do not well comprehend it. Give me an example of such an examination of a Theory.” “It is too great a labour,” says he, “for one so old as I am.” “Well then, you, Zeno,” says Socrates, “will you not give us such an example?” Zeno answers, smiling, that they had better get it from Parmenides himself; and joins in the petition of Socrates to him, that he will instruct them. All the company unite in the request. Parmenides compares himself to an aged racehorse, brought to the course after long disuse, and trembling at the risk; but finally consents. And as an example of a Theory to be examined, takes his own Doctrine, that All Things are One, carrying on the Dialogue thenceforth, not with Socrates, but with Aristoteles (not the Stagirite, but afterwards one of the Thirty), whom he chooses as a younger and more manageable respondent.

The discussion of this Doctrine is of a very subtle kind, and it would be difficult to make it intelligible to a modern reader. Nor is it necessary for my purpose to attempt to do so. It is plain that the discussion is intended seriously, as an example of true philosophy; and each step of the process is represented as irresistible. The Respondent has nothing to say but *Yes*; or *No*; *How so?* *Certainly*; *It does appear*; *It does not appear*. The discussion is carried to a much greater length than all the rest of the Dialogue; and the result of the reasoning is summed up by Parmenides thus: “If One exist, it is Nothing. Whether One exist or do not exist, both It and Other Things both with regard to Themselves and to Each other, All and Every way are and are not, appear and appear not.” And this also is fully assented to; and so the Dialogue ends.

I shall not pretend to explain the Doctrines there examined that One exists, or One does not exist, nor to trace their consequences. But these were Formulæ, as familiar in the Eleatic school, as Ideas in the Platonic; and were undoubtedly regarded by the Megaric contemporaries of Plato as quite worthy of being discussed, after the Theory of Ideas had been overthrown. This, accordingly, appears to be the purport of the Dialogue; and it is pursued, as we see, without any bitterness towards Socrates or his disciples; but with a persuasion that they were poor philosophers, conceited talkers, and weak disputants.

The external circumstances of the Dialogue tend, I conceive, to confirm this opinion, that it is not Plato's. The Dialogue begins, as the *Republic* begins, with the mention of a Cephalus, and two brothers, Glaucon and Adimantus. But this Cephalus is not the old man of the Piræus, of whom we have so charming a picture in the opening of the *Republic*. He is from Clazomenæ, and tells us that his fellow-citizens are great lovers of philosophy; a trait of their character which does not appear elsewhere. Even the brothers Glaucon and Adimantus are not the two brothers of Plato who conduct the Dialogue in the later books of the *Republic*: so at least Ast argues, who holds the genuineness of the Dialogue. This

Glaucon and Adimantus are most wantonly introduced; for the sole office they have, is to say that they have a half-brother Antiphon, by a second marriage of their mother. No such half-brother of Plato, and no such marriage of his mother, are noticed in other remains of antiquity. Antiphon is represented as having been the friend of Pythodorus, who was the host of Parmenides and Zeno, as we have seen. And Antiphon, having often heard from Pythodorus the account of the conversation of his guests with Socrates, retained it in his memory, or in his tablets, so as to be able to give the full report of it which we have in the Dialogue *Parmenides**. To me, all this looks like a clumsy imitation of the Introductions to the Platonic Dialogues.

I say nothing of the chronological difficulties which arise from bringing Parmenides and Socrates together, though they are considerable; for they have been explained more or less satisfactorily; and certainly in the *Theætetus*, Socrates is represented as saying that he when very young had seen Parmenides who was very old†. Athenæus, however‡, reckons this among Plato's fictions. Schleiermacher gives up the identification and relation of the persons mentioned in the Introduction as an unmanageable story.

I may add that I believe Cicero, who refers to so many of Plato's Dialogues, nowhere refers to the *Parmenides*. Athenæus does refer to it; and in doing so blames Plato for his coarse imputations on Zeno and Parmenides. According to our view, these are hostile attempts to ascribe rudeness to Socrates or to Plato. Stallbaum acknowledges that Aristotle nowhere refers to this Dialogue.

* In the *First Alcibiades*, Pythodorus is mentioned as having paid 100 minæ to Zeno for his instructions (119 A).

† p. 183 e.

‡ *Deipn.* xi. c. 15, p. 105.

VI. *On the Discontinuity of Arbitrary Constants which appear in Divergent Developments.* By G. G. STOKES, M.A., D.C.L., Sec. R.S., *Fellow of Pembroke College, and Lucasian Professor of Mathematics in the University of Cambridge.*

[Read May 11, 1857.]

IN a paper "On the Numerical Calculation of a class of Definite Integrals and Infinite Series," printed in the ninth volume of the *Transactions* of this Society, I succeeded in developing the integral $\int_0^\infty \cos \frac{\pi}{2} (w^3 - mw) dw$ in a form which admits of extremely easy numerical calculation when m is large, whether positive or negative, or even moderately large. The method there followed is of very general application to a class of functions which frequently occur in physical problems. Some other examples of its use are given in the same paper; and I was enabled by the application of it to solve the problem of the motion of the fluid surrounding a pendulum of the form of a long cylinder, when the internal friction of the fluid is taken into account*.

These functions admit of expansion, according to ascending powers of the variables, in series which are always convergent, and which may be regarded as defining the functions for all values of the variable real or imaginary, though the actual numerical calculation would involve a labour increasing indefinitely with the magnitude of the variable. They satisfy certain linear differential equations, which indeed frequently are what present themselves in the first instance, the series, multiplied by arbitrary constants, being merely their integrals. In my former paper, to which the present may be regarded as a supplement, I have employed these equations to obtain integrals in the form of descending series multiplied by exponentials. These integrals, when once the arbitrary constants are determined, are exceedingly convenient for numerical calculation when the variable is large, notwithstanding that the series involved in them, though at first rapidly convergent, became ultimately rapidly divergent.

The determination of the arbitrary constants may be effected in two ways, numerically or analytically. In the former, it will be sufficient to calculate the function for one or more values of the variable from the ascending and descending series separately, and equate the results. This method has the advantage of being generally applicable, but is wholly devoid of elegance. It is better, when possible, to determine analytically the relations between the

* *Camb. Phil. Trans.* Vol. IX. Part II.

arbitrary constants in the ascending and descending series. In the examples to which I have applied the method, with one exception, this was effected, so far as was necessary for the physical problem, by means of a definite integral, which either was what presented itself in the first instance, or was employed as one form of the integral of the differential equation, and in either case formed a link of connexion between the ascending and the descending series. The exception occurs in the case of Mr. Airy's integral for m negative. I succeeded in determining the arbitrary constants in the divergent series for m positive; but though I was able to obtain the correct result for m negative, I had to profess myself (p. 177) unable to give a satisfactory demonstration of it.

But though the arbitrary constants which occur as coefficients of the divergent series may be completely determined for real values of the variable, or even for imaginary values with their amplitudes lying between restricted limits, something yet remains to be done in order to render the expression by means of divergent series analytically perfect. I have already remarked in the former paper (p. 176) that inasmuch as the descending series contain radicals which do not appear in the ascending series, we may see, *a priori*, that the arbitrary constants must be discontinuous. But it is not enough to know that they must be discontinuous; we must also know where the discontinuity takes place, and to what the constants change. Then, and not till then, will the expressions by descending series be complete, inasmuch as we shall be able to use them for all values of the amplitude of the variable.

I have lately resumed this subject, and I have now succeeded in ascertaining the character by which the liability to discontinuity in these arbitrary constants may be ascertained. I may mention at once that it consists in this; that an associated divergent series comes to have all its terms regularly positive. The expression becomes thereby *to a certain extent* illusory; and thus it is that analysis gets over the apparent paradox of furnishing a discontinuous expression for a continuous function. It will be found that the expressions by divergent series will thus acquire all the requisite generality, and that though applied without any restriction as to the amplitude of the variable they will contain only as many unknown constants as correspond to the degree of the differential equation. The determination, among other things, of the constants in the development of Mr Airy's integral will thus be rendered complete.

1. Before proceeding to more difficult examples, it will be well to consider a comparatively simple function, which has been already much discussed. As my object in treating this function is to facilitate the comprehension of methods applicable to functions of much greater complexity, I shall not take the shortest course, but that which seems best adapted to serve as an introduction to what is to follow.

Consider the integral

$$u = 2 \int_0^{\infty} e^{-x^2} \sin 2ax dx = \frac{2a}{1} - \frac{(2a)^3}{2 \cdot 3} + \frac{(2a)^5}{3 \cdot 4 \cdot 5} \dots \dots (1)$$

The integral and the series are both convergent for all values of a , and either of them completely defines u for all values real or imaginary of a . We easily find from either the integral or the series

$$\frac{du}{da} + 2au = 2 \dots\dots\dots (2)$$

This equation gives, if we observe that $u = 0$ when $a = 0$,

$$u = 2e^{-a^2} \int_0^a e^{a^2} da = 2e^{-a^2} \left\{ a + \frac{a^3}{1.3} + \frac{a^5}{1.2.5} + \frac{a^7}{1.2.3.7} + \dots \right\} \dots\dots (3)$$

This integral or series like the former gives a determinate and unique value to u for any assigned value of a real or imaginary. Both series, however, though ultimately convergent, begin by diverging rapidly when the modulus of a is large. For the sake of brevity I shall hereafter speak of an imaginary quantity simply as large or small when it is meant that its modulus is large or small.

2. In order to obtain u in a form convenient for calculation when a is large, let us seek to express u by means of a descending series. We see from (2) that when the real part of a^2 is positive, the most important terms of the equation are $2au$ and 2 , and the leading term of the development is a^{-1} . Assuming a series with arbitrary indices and coefficients, and determining them so as to satisfy the equation, we readily find

$$u = \frac{1}{a} + \frac{1}{2a^3} + \frac{1.3}{2^2 a^5} + \dots$$

This series can be only a particular integral of (2), since it wants an arbitrary constant. To complete the integral we must add the complete integral of

$$\frac{du}{da} + 2au = 0,$$

whence we get for the complete integral of (2)

$$u = Ce^{-a^2} + \frac{1}{a} + \frac{1}{2a^3} + \frac{1.3}{2^2 a^5} + \frac{1.3.5}{2^3 a^7} + \dots\dots\dots (4)$$

This expression might have been got at once from (3) by integration by parts. It remains to determine the arbitrary constant C .

3. The expression (1) or (3) shews that u is an odd function of a , changing sign with a . But according to (4) u is expressed as the sum of two functions, the first even, the second odd, unless $C = 0$, in which case the even function disappears. But since, as we shall presently see, the value of C is not zero, it must change sign with a . Let

$$a = \rho (\cos \theta + \sqrt{-1} \sin \theta).$$

Since in the application of the series (4) it is supposed that ρ is large, we must suppose a to change sign by a variation of θ , which must be increased or diminished (suppose increased) by π . Hence, if we knew what C was for a range π of θ , suppose from $\theta = \alpha$ to $\theta = \alpha + \pi$, we should know at once what it was from $\theta = \alpha + \pi$ to $\theta = \alpha + 2\pi$, which would be sufficient

for our purpose, since we may always suppose the amplitude of α included in the range α to $\alpha + 2\pi$, by adding, if need be, a positive or negative multiple of 2π , which as appears from (1) or (3) makes no difference in the value of u .

4. When ρ is large the series (4) is at first rapidly convergent, but be ρ ever so great it ends by diverging with increasing rapidity. Nevertheless it may be employed in calculation provided we do not push the series too far, but stop before the terms get large again. To shew in a general way the legitimacy of this, we may observe that if we stop with the term

$$\frac{1 \cdot 3 \cdot 5 \dots (2i - 1)}{2^i a^{2i+1}},$$

the value of u so obtained will satisfy exactly, not (2), but the differential equation

$$\frac{du}{da} + 2au = 2 - \frac{1 \cdot 3 \dots (2i + 1)}{2^i a^{2i+3}} \dots \dots \dots (5)$$

Let u_0 be the true value of u for a large value a_0 of a , and suppose that we pass from a_0 to another large value of a keeping the modulus of a large all the while. Since u ought to satisfy (2), we ought to have

$$u = u_0 + 2e^{-a^2} \int_{a_0}^a e^{a^2} da,$$

whereas since our approximate expression for u actually satisfies (5) we actually have, putting A_i for the last term,

$$u = u_0 + e^{-a^2} \int_{a_0}^a (2 - A_i) e^{a^2} da \dots \dots \dots (6)$$

If a be very large, and in using the series (4) we stop about where the moduli of the terms are smallest, the modulus of A_i will be very small. Hence in general A_i may be neglected in comparison with (2), and we may use the expression (4), though we stop after $i + 1$ terms of the series, as a near approximation to u .

5. But to this there is an important restriction, to understand which more readily it will be convenient to suppose the integration from a_0 to a performed, first by putting

$$da = (\cos \theta + \sqrt{-1} \sin \theta) d\rho,$$

and integrating from ρ_0 to ρ , θ remaining equal to θ_0 , and then

$$da = \rho (-\sin \theta + \sqrt{-1} \cos \theta) d\theta,$$

and integrating from θ_0 to θ , ρ remaining unchanged. This is allowable, since u is a finite, continuous, and determinate function of a , and therefore the mode in which ρ and θ vary when a passes from its initial value a_0 to its final value a is a matter of indifference. The modulus of e^{a^2} will depend on the real part $\rho^2 \cos 2\theta$ of the index. Now should $\cos 2\theta$ become a maximum within the limits of integration, we can no longer neglect A_i in the integration. For however great may be the value previously assigned to i , the quantity $\rho^{-2i-1} e^{\rho^2 \cos 2\theta}$ will become, for values of θ comprised within the limits of integration, infinitely great, when ρ is infinitely increased, compared with the value of $e^{\rho^2 \cos 2\theta}$ at either limit. And though the modulus of the quantity $2e^{a^2}$ under the integral sign will become far greater still, inasmuch as it does not con-

tain the factor ρ^{-2i-1} , yet as the mutual destruction of positive and negative parts may take place quite differently in the two integrals $\int 2e^{a^2} da$ and $\int 4_1 e^{a^2} da$, we can conclude nothing as to their relative importance.

6. Now $\cos 2\theta$ will continually increase or decrease from one limit to the other, or else will become a maximum, according as the two limits θ_0 and θ lie in the same interval 0 to π or π to 2π , or else lie one in one of the two intervals and the other in the other. Hence we may employ the expression (4), with an invariable value of C yet to be determined, so long as $0 < \theta < \pi$, and we may employ the expression obtained by writing C' for C so long as $\pi < \theta < 2\pi$, but we must not pass from one interval to the other, retaining the same expression. Now we have seen (Art. 3) that the constant changes sign when θ is increased by π , and therefore $C' = -C$. And since u is unchanged when θ is increased by any multiple of 2π , we readily see that in order to make the expression (4) generally applicable, it will be sufficient to change the sign of the constant whenever θ passes through zero or a multiple of π .

7. We may arrive at the same conclusion in another way, which will be of more general or at least easier application, as not involving the integration of the differential equation.

The modulus of the general term (Art. 4) of the series (4), expressed by means of the function Γ , is

$$\frac{\Gamma(i + \frac{1}{2})}{\Gamma(\frac{1}{2}) \rho^{2i+1}}$$

Suppose i very large. Employing the formula

$$\Gamma(x + 1) = \sqrt{2\pi x} \left(\frac{x}{e}\right)^x, \text{ nearly, when } x \text{ is large,}$$

observing that $\Gamma(\frac{1}{2}) = \pi^{\frac{1}{2}}$, and calling the modulus μ_i , we find

$$\mu_i = 2^{\frac{1}{2}} (i - \frac{1}{2})^i e^{-i+\frac{1}{2}} \rho^{-2i-1},$$

which, since $(i + c)^i = i^i e^c$, nearly, becomes

$$\mu_i = 2^{\frac{1}{2}} i^i e^{-i} \rho^{-2i-1} \dots\dots\dots (7)$$

We easily get, either from this expression or from the general term,

$$\frac{\mu_{i+1}}{\mu_i} = \frac{i}{\rho^2}, \text{ nearly, } \dots\dots\dots (8)$$

Hence when ρ is large the ratio of consecutive moduli becomes very nearly equal to unity for a great number of terms together, about where the modulus is a minimum. To find approximately the minimum modulus μ , we must put $i = \rho^2$ in (7), which gives

$$\mu = 2^{\frac{1}{2}} \rho^{-1} e^{-\rho^2} \dots\dots\dots (9)$$

If we knew precisely at what term it would be best to stop, the expression for μ would be a measure of the uncertainty to which we were liable in using the series (4) directly, that is, without any transformation. For although it is clear that we must stop *somewhere about* the term with a minimum modulus, in order that the differential equation (5) which our function really satisfies may be as good an approximation as can be had to the true differential

equation (2), the number of terms comprised in this *about* will increase with i , the order of the term of minimum modulus. If we suppose that we are uncertain to the extent of n terms, the sum of the moduli of these n nearly equal terms will be

$$2^{\frac{1}{2}} n \rho^{-1} e^{-\rho^2},$$

nearly. It seems as if n must increase with i , but not so fast as i . If we suppose that it is of the form $k i^{\frac{1}{2}}$ or $h \rho$, the sum of the n terms will be a quantity of the order $e^{-\rho^2}$. But even if n increased as any power p of i , however great, still the sum of the n terms would be a quantity of the order $\rho^{2p-1} e^{-\rho^2}$, which when ρ was infinitely increased would become infinitely small in comparison with the modulus $e^{-\rho^2 \cos 2\theta}$ of the term multiplied by C in (4), provided θ had any given value differing from zero or a multiple of π . Hence if θ have any value lying between a and $\pi - a$, or else between $\pi + a$ and $2\pi - a$, where a is a small positive quantity which in the end may be made as small as we please, the quantity C in (4) cannot pass from one of its values to another without rendering the function u discontinuous, which it is not. But when $\theta = 0$ or $= \pi$, the term $C e^{-a^2}$ becomes merged in the vagueness with which, in this case, the divergent series defines the function. Hence we arrive in a way quite different from that of Art. 5 at the conclusions enunciated in Art. 6.

8. Nor is this all. When the terms of a regular series are alternately positive and negative, the series may be converted by the formulæ of finite differences into others which converge rapidly. In the present case the terms are not simply positive and negative alternately, except when θ is an odd multiple of $\frac{\pi}{2}$, but the same methods will apply with the proper modification. Suppose that we sum the series (4) directly as far as terms of the order $i - 1$ inclusive. Omitting the common factor $e^{-(i+1)\theta\sqrt{-1}}$, which may be restored in the end, we have for the rest of the series

$$\mu_i + e^{-2\theta\sqrt{-1}} \mu_{i+1} + e^{-4\theta\sqrt{-1}} \mu_{i+2} + \dots$$

If we denote by D or $1 + \Delta$ the operation of passing from μ_i to μ_{i+1} , and separate symbols of operation, this becomes

$$(1 + e^{-2\theta\sqrt{-1}} D + e^{-4\theta\sqrt{-1}} D^2 + \dots) \mu_i,$$

$$\text{or } \{1 - (1 + \Delta) e^{-2\theta\sqrt{-1}}\}^{-1} \mu_i.$$

$$\text{Now } 1 - e^{-2\theta\sqrt{-1}} = 1 - \cos 2\theta + \sqrt{-1} \sin 2\theta = 2 \sin \theta e^{(\frac{\pi}{2} - \theta)\sqrt{-1}},$$

which reduces the expression to

$$(2 \sin \theta)^{-1} e^{(\frac{\theta - \pi}{2})\sqrt{-1}} \{1 - (2 \sin \theta)^{-1} e^{-(\frac{\pi}{2} + \theta)\sqrt{-1}} \Delta\}^{-1} \mu_i$$

or, putting q for $(2 \sin \theta)^{-1}$, to

$$q e^{(\frac{\theta - \pi}{2})\sqrt{-1}} \mu_i + q^2 e^{-\pi\sqrt{-1}} \Delta \mu_i + q^3 e^{-(\frac{3\pi}{2} + \theta)\sqrt{-1}} \Delta^2 \mu_i + \dots$$

Now if ρ be very large, and μ_i belong to the part of the series where the moduli of consecutive terms are nearly equal, the successive differences $\Delta \mu_i$, $\Delta^2 \mu_i$, ... will decrease with great rapidity. Hence if θ have any given value different from zero or a multiple of π , by taking

ρ sufficiently great, we may transform the series about where it ceases to converge into one which is at first rapidly convergent, and thus a quantity which may be taken as a measure of the remaining uncertainty will become incomparably smaller even than μ , much more, incomparably smaller than the modulus of e^{-a^2} . But if $\theta = 0$ or $= \pi$, the above transformation fails, since q becomes infinite. In this case if we want to calculate u closer than to admit of the uncertainty to which we are liable, knowing only that we must stop *somewhere about* the place where the series begins to diverge after having been convergent, we must have recourse to the ascending series (1) or (3), or to some perfectly distinct method. The usual method by which $\sum u_n$ is made to depend on $\int u_x dx$ would evidently fail, in consequence of the divergence of the integral.

9. In applying *practically* the transformation of the last article to the summation of the series (4), it would not usually, when ρ was very large, be necessary to go as far as the part of the series where the moduli of consecutive terms are nearly equal. It would be sufficient to deduct $l; 2l\dots$ from the logarithms of $\mu_{i+1}, \mu_{i+2}\dots$, where l is nearly equal to the mean increment of the logarithms at that part of the series, to associate the factor f whose logarithm is l with the symbol D , and take the differences of the numbers,

$$\mu_i, f^{-1}\mu_{i+1}, f^{-2}\mu_{i+2}, \&c.$$

However, my object leads me to consider, not the actual summation of the series, but the theoretical possibility of summation, and consequent interpretation of the equation (4).

10. The mode of discontinuity of the constant C having been now ascertained, nothing more remains except to determine that constant, which is done at once. Writing $\sqrt{-1}a$ for a in (4) after having put for u its first expression in (3), we have

$$2e^{a^2} \int_0^a e^{-a^2} da = -\sqrt{-1} C e^{a^2} - \frac{1}{a} + \frac{1}{2a^3} - \dots$$

whence, putting $a = \infty$, we have $C = \sqrt{-1} \pi^{\frac{1}{2}}$. Hence we get for the general expression for C in (4),

$$\left. \begin{aligned} C &= \sqrt{-1} \pi^{\frac{1}{2}}, \text{ when } 0 < \theta < \pi, \\ C &= -\sqrt{-1} \pi^{\frac{1}{2}} \text{ when } \pi < \theta < 2\pi; \end{aligned} \right\} \dots\dots\dots (10)$$

and therefore from (3) and (4)

$$2e^{-a^2} \int_0^a e^{a^2} da = \pm \sqrt{-1} \pi^{\frac{1}{2}} e^{-a^2} + \frac{1}{a} + \frac{1}{2a^3} + \frac{1.3}{2^2 a^5} + \frac{1.3.5}{2^3 a^7} + \dots\dots\dots (11)$$

the sign being $+$ or $-$ according as θ , the amplitude of a , is comprised within the limits 0 and π , or π and 2π .

Writing $a\sqrt{-1}$ for a in (11), which comes to altering the origin of θ by $\frac{\pi}{2}$, we find

$$2e^{a^2} \int_0^a e^{-a^2} da = \pm \pi^{\frac{1}{2}} e^{a^2} - \frac{1}{a} + \frac{1}{2a^3} - \frac{1.3}{2^2 a^5} + \frac{1.3.5}{2^3 a^7} - \dots\dots\dots (12)$$

the sign being + or - according as the amplitude of a lies within the limits $-\frac{\pi}{2}$ and $\frac{\pi}{2}$, or $\frac{\pi}{2}$ and $\frac{3\pi}{2}$. It is worthy of remark that in this expression the transcendental quantity $\pi^{\frac{1}{2}}$ appears as a true radical, admitting of the double sign.

Two cases of the integral $\int_0^a e^{a^2} da$ occur in actual investigations, namely when $\theta = \frac{\pi}{2}$, when the integral leads to $\int_{\frac{\pi}{2}}^t e^{-t^2} dt$, which occurs in the theory of probabilities, and when $\theta = \frac{\pi}{4}$, when it leads to Fresnel's integrals $\int_0^s \cos\left(\frac{\pi}{2}s^2\right) ds$ and $\int_0^s \sin\left(\frac{\pi}{2}s^2\right) ds$. In the latter case the expression (11) is equivalent to the development of these integrals which has been given by M. Cauchy.

11. If in equation (11) we put $a = \rho (\cos \theta \pm \sqrt{-1} \sin \theta)$, where θ is a small positive quantity, and after equating the real parts of both sides of the equation make θ vanish, we find, whichever sign be taken,

$$\frac{1}{\rho} + \frac{1}{2\rho^3} + \frac{1 \cdot 3}{2^2 \rho^5} + \frac{1 \cdot 3 \cdot 5}{2^3 \rho^7} + \dots = 2e^{-\rho^2} \int_0^{\rho} e^{\rho^2} d\rho \dots \dots \dots (13)$$

The expression which appears on the second side of this equation may be regarded as a *singular value* of the sum of the series

$$\frac{1}{a} + \frac{1}{2a^3} + \frac{1 \cdot 3}{2^2 a^5} + \frac{1 \cdot 3 \cdot 5}{2^3 a^7} + \dots \dots \dots (14)$$

a series which when θ vanishes *takes the form* of the first member of the equation. The equivalent of the series for general values of the variable is given, not by (13), but by (11). It may be remarked that the singular value is the mean of the general values for two infinitely small values of θ , one positive and the other negative.

These results, to which we are led by analysis, may be compared with the known theory of periodic series. If $f(x)$ be a finite function of x , the value of which changes abruptly from a to b as x increases through the value c , a quantity lying between 0 and π , and $f(x)$ be expanded between the limits 0 and π in a series of sines of multiples of x , and if $\phi(n, x)$ be the sum of n terms of the series, the value of $\phi(n, x)$ for an infinitely large value of n and a value of x infinitely near to c is indeterminate, like that of the fraction

$$\frac{(x + y)^2 + x - y}{(x - y)^2 + x + y},$$

which takes the form $\frac{0}{0}$ when x and y vanish, but of which the limiting value is wholly indeterminate if x and y are independent. We may enquire, if we please, what is the limit of the fraction when x first vanishes and then y , or the limit when y first vanishes and then x , for each of these has a perfectly clear and determinate signification. In the former case we have, calling the fraction $\psi(x, y)$,

$$\lim_{y=0} \lim_{x=0} \psi(x, y) = \lim_{y=0} \frac{y^3 - y}{y^2 + y} = -1;$$

in the latter

$$\lim_{x=0} \lim_{y=0} \psi(x, y) = \lim_{x=0} \frac{x^3 + x}{x^2 + x} = 1.$$

So in the case of the periodic series if we denote by ξ a small positive quantity

$$\lim_{\xi=0} \lim_{n=\infty} \phi(n, c - \xi) = \lim_{\xi=0} f(c - \xi) = a,$$

$$\lim_{\xi=0} \lim_{n=\infty} \phi(n, c + \xi) = \lim_{\xi=0} f(c + \xi) = b;$$

but we know that

$$\lim_{n=\infty} \lim_{\xi=0} \phi(n, c \pm \xi) = \lim_{n=\infty} \phi(n, c) = \frac{1}{2}(a + b).$$

Similarly in the case of the series (14) if we denote its sum by $\chi(a) = \varpi(\rho, \theta)$, and use the term *limit* in an extended sense, so as to understand by $\lim_{\rho=\infty} F(\rho)$ a function of ρ to which $F(\rho)$ may be regarded as equal when ρ is large enough, and if we suppose θ to be a small positive quantity, we have from (11)

$$\begin{aligned} \lim_{\theta=0} \lim_{\rho=\infty} \varpi(\rho, \theta) &= \lim_{\theta=0} \left\{ 2e^{-\theta^2} \int_0^{\rho} e^{a^2} da - \sqrt{-1} \pi^{\frac{1}{2}} e^{-\theta^2} \right\} \\ &= 2e^{-\theta^2} \int_0^{\rho} e^{a^2} d\rho - \sqrt{-1} \pi^{\frac{1}{2}} e^{-\theta^2}; \end{aligned}$$

$$\begin{aligned} \lim_{\theta=0} \lim_{\rho=\infty} \varpi(\rho, -\theta) &= \lim_{\theta=0} \left\{ 2e^{-\theta^2} \int_0^{\rho} e^{a^2} da + \sqrt{-1} \pi^{\frac{1}{2}} e^{-\theta^2} \right\} \\ &= 2e^{-\theta^2} \int_0^{\rho} e^{a^2} d\rho + \sqrt{-1} \pi^{\frac{1}{2}} e^{-\theta^2}, \end{aligned}$$

whereas equation (13) may be expressed by

$$\lim_{\rho=\infty} \lim_{\theta=0} \varpi(\rho, \pm \theta) = \lim_{\rho=\infty} \chi(\rho) = 2e^{-\rho^2} \int_0^{\rho} e^{a^2} d\rho.$$

There is however this difference between the two cases, that in the case of the periodic series the series whose general term is $\Delta\phi(n, c)$ is convergent, and may be actually summed to any assigned degree of accuracy, whereas the series (13), though at first convergent, is ultimately divergent; and though we know that we must stop somewhere about the least term, that alone does not enable us to find the sum, except subject to an uncertainty comparable with $e^{-\rho^2}$. Unless therefore it be possible to apply to the series (13) some transformation rendering it capable of summation to a degree of accuracy incomparably superior to this, the equation (13) must be regarded as a mere symbolical result. We might indeed *define* the sum of the ultimately divergent series (13) to mean the sum taken to as many terms as should *make* the equation (13) true, and express that condition in a manner which would not require the quantity taken to denote the number of terms to be integral; but

then equation (13) would become a mere truism. However I shall not pursue this subject further, as these singular values of divergent series appear to be merely matters of curiosity.

12. In order still further to illustrate the subject, before going on to the actual application of the principles here established, let us consider the function defined by the equation

$$u = 1 + \frac{1}{2}x - \frac{1 \cdot 1}{2 \cdot 4}x^2 + \frac{1 \cdot 1 \cdot 3}{2 \cdot 4 \cdot 6}x^3 - \dots \dots \dots (15)$$

Suppose that we have to deal with such values only of the imaginary variable x as have their moduli less than unity. For such values the series (15) is convergent, and the equation (15) assigns a determinate and unique value to u . Now we happen to know that the series is the development of $(1+x)^{\frac{1}{2}}$. But this function admits of one or other of the following developments according to descending powers of x :—

$$u = x^{\frac{1}{2}} + \frac{1}{2}x^{-\frac{1}{2}} - \frac{1 \cdot 1}{2 \cdot 4}x^{-\frac{3}{2}} + \frac{1 \cdot 1 \cdot 3}{2 \cdot 4 \cdot 6}x^{-\frac{5}{2}} - \dots \dots \dots (16)$$

$$u = -x^{\frac{1}{2}} - \frac{1}{2}x^{-\frac{1}{2}} + \frac{1 \cdot 1}{2 \cdot 4}x^{-\frac{3}{2}} - \frac{1 \cdot 1 \cdot 3}{2 \cdot 4 \cdot 6}x^{-\frac{5}{2}} + \dots \dots \dots (17)$$

Let $x = \rho (\cos \theta + \sqrt{-1} \sin \theta)$, and let $x^{\frac{1}{2}}$ denote that square root of x which has $\frac{1}{2}\theta$ for its amplitude. Although the series (16), (17) are divergent when $\rho < 1$, they may in general, for a given value of θ , be employed in actual numerical calculation, by subjecting them to the transformation of Art. 8, provided ρ do not differ too much from 1. The greater be the accuracy required, θ being given, the less must ρ differ from 1 if we would employ the series (16) or (17) in place of (15). It remains to be found which of these series must be taken.

If θ lie between $(2i-1)\pi + \alpha$ and $(2i+1)\pi - \alpha$, where i is any positive or negative integer or zero, and α a small positive quantity which in the end may be made as small as we please, either series (16) or (17) may by the method of Art. 8 be converted into another, which is at first sufficiently convergent to give u with a sufficient degree of accuracy by employing a finite number only of terms. If m terms be summed directly, and in the formula of Art. 8 the n^{th} difference be the last which yields significant figures, the number of terms actually employed in some way or other in the summation will be $m+n+1$. And in this case we cannot pass from one to the other of the two series (16), (17) without rendering u discontinuous. But when θ passes through an odd multiple of π we may have to pass from one of the two series to the other. Now when θ is increased by 2π the series (16) or (17) changes sign, whereas (15) remains unchanged. Therefore in calculating u for two values of θ differing by 2π we must employ the two series (16) and (17), one in each case. Hence we must employ one of the series from $\theta = -\pi$ to $\theta = \pi$, the other from $\theta = \pi$ to $\theta = 3\pi$, and so on; and therefore if we knew which series to take for some one value of w everything would be determined.

Now when $\rho = 1$ the series (15) becomes identical with (16) when θ has the particular value 0. Hence (16) and not (17) gives the true value of u when $-\pi < \theta < \pi$.

13. Let ρ, θ be the polar co-ordinates of a point in a plane, O the origin, C a circle described round O with radius unity, S the point determined by $x = -1$, that is, by $\rho = 1, \theta = \pi$. To each value of x corresponds a point in the plane; and the restriction laid down as to the moduli of x confines our attention to points within the circle, to each of which corresponds a determinate value of u . If P_0 be any point in the plane, either within the circle or not, and a moveable point P start from P_0 , and after making any circuit, without passing through S , return to P_0 again, the function $(1+x)^{\frac{1}{2}}$ will regain its primitive value u_0 , or else become equal to $-u_0$, according as the circuit excludes or includes the point S , which for the present purpose may be called a *singular point*. Suppose that we wished to tabulate u , using when possible the divergent series (16) in place of the convergent series (15). For a given value of θ , in commencing with small values of ρ we should have to begin with the series (15), and when ρ became large enough we might have recourse to (16). Let OP be the smallest value of ρ for which the series (16) may be employed; for which, suppose, it will give u correctly to a certain number of decimal places. The length OP will depend upon θ , and the locus of P will be some curve, symmetrical with respect to the diameter through S . As θ increases the curve will gradually approach the circle C , which it will run into at the point S . For points lying between the curve and the circle we may employ the series (16), but we cannot, keeping within this space, make θ pass through the value π . The series (16), (17) are convergent, and their sums vary continuously with x , when $\rho > 1$; and if we employed the same series (16) for the calculation of u for values of x having amplitudes $\pi - \beta, \pi + \beta$, corresponding to points P, P' , we should get for the value of u at P' that into which the value of u at P passes continuously when we travel from P to P' *outside* the point S , which as we have seen is *minus* the true value, the latter being defined to be that into which the value of u at P passes continuously when we travel from P to P' *inside* the point S .

In the case of the simple function at present under consideration, it would be an arbitrary restriction to confine our attention to values of x having moduli less than unity, nor would there be any advantage in using the divergent series (16) rather than the convergent series (15). But in the example first considered we have to deal with a function which has a perfectly determinate and unique value for all values of the variable a , and there is the greatest possible advantage in employing the descending series for large values of ρ , though it is ultimately divergent. In the case of this function there are (to use the same geometrical illustration as before) as it were two singular points at infinity, corresponding respectively to $\theta = 0$ and $\theta = \pi$.

14. The principles which are to guide us having been now laid down, there will be no difficulty in applying them to other cases, in which their real utility will be perceived. I will now take Mr Airy's integral, or rather the differential equation to which it leads, the treatment of which will exemplify the subject still better. This equation, which is No. 11 of my paper "On the Numerical Calculation, &c.," becomes on writing u for $U, -3a$ for n

$$\frac{d^2u}{dx^2} - 9xu = 0 \dots\dots\dots (18)$$

The complete integral of this equation in ascending series, obtained in the usual way, is

$$u = A \left\{ 1 + \frac{9x^3}{2.3} + \frac{9^2x^6}{2.3.5.6} + \frac{9^3x^9}{2.3.5.6.8.9} + \dots \right\} + B \left\{ x + \frac{9x^4}{3.4} + \frac{9^2x^7}{3.4.6.7} + \frac{9^3x^{10}}{3.4.6.7.9.10} + \dots \right\} \dots\dots\dots (19)$$

These series are always convergent, and for any value of x real or imaginary assign a determinate and unique value to u .

The integral in a form adapted for calculation when x is large, obtained by the method of my former paper, is

$$u = Cx^{-\frac{1}{2}}e^{-2x^2} \left\{ 1 - \frac{1.5}{1.144x^{\frac{1}{2}}} + \frac{1.5.7.11}{1.2.144^2x^3} - \frac{1.5.7.11.13.17}{1.2.3.144^3x^{\frac{9}{2}}} + \dots \right\} + Dx^{-\frac{1}{2}}e^{2x^2} \left\{ 1 + \frac{1.5}{1.144x^{\frac{1}{2}}} + \frac{1.5.7.11}{1.2.144^2x^3} + \frac{1.5.7.11.13.17}{1.2.3.144^3x^{\frac{9}{2}}} + \dots \right\} \dots\dots\dots (20)$$

The constants C, D must however be discontinuous, since otherwise the value of u determined by this equation would not recur, as it ought, when the amplitude of x is increased by 2π . We have now first to ascertain the mode of discontinuity of these constants, secondly, to find the two linear relations which connect A, B with C, D .

Let the equation (20) be denoted for shortness by

$$u = Cx^{-\frac{1}{2}}f_1(x) + Dx^{-\frac{1}{2}}f_2(x); \dots\dots\dots (21)$$

and let $f(x)$, when we care only to express its dependance on the amplitude of x , be denoted by $F(\theta)$. We may notice that

$$F_1(\theta + \frac{2}{3}\pi) = F_2(\theta); \quad F_2(\theta + \frac{2}{3}\pi) = F_1(\theta) \dots\dots\dots (22)$$

15. In equation (21), let that term in which the real part of the index of the exponential is positive be called the *superior*, and the other the *inferior* term. In order to represent to the eye the existence and progress of the functions $f_1(x), f_2(x)$ for different values of θ , draw a circle with any radius, and along a radius vector inclined to the prime radius at the variable angle θ take two distances, measured respectively outwards and inwards from the circumference of the circle, proportional to the real part of the index of the exponential in the superior and inferior terms, θ alone being supposed to vary, or in other words proportional to $\cos \frac{2}{3}\theta$. For greater convenience suppose these distances moderately small compared with the radius.

Fig. 1.

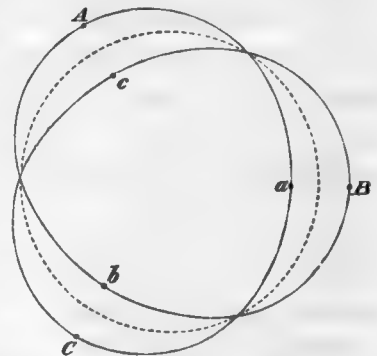

Consider first the function $F_1(\theta)$ alone. The curve will evidently have the form represented in the figure, cutting the circle at intervals of 120° , and running into itself after two complete revolutions. The equations (22) shew that the curve corresponding to $F_2(\theta)$ is already

traced, since $F_2(\theta) = F_1(\theta + 2\pi)$. If now we conceive the curve marked with the proper values of the constants C, D , it will serve to represent the complete integral of equation (18).

In marking the curve we may either assume the amplitude θ of x to lie in the interval 0 to 2π , and determine the values of C, D accordingly, or else we may retain the same value of C or D throughout as great a range as possible of the curve, and for that purpose permit θ to go beyond the above limits. The latter course will be found the more convenient.

16. We must now ascertain in what cases it is possible for the constant C or D to alter discontinuously as θ alters continuously. The tests already given will enable us to decide.

The general term of either series in (20), taken without regard to sign, is

$$\frac{1 \cdot 5 \dots (6i - 5) (6i - 1)}{1 \cdot 2 \dots i (144\rho^{\frac{1}{3}})^i};$$

and the modulus of this term, expressed by means of the function Γ , is

$$\frac{\Gamma(i + \frac{1}{6}) \Gamma(i + \frac{5}{6})}{\Gamma(\frac{1}{6}) \Gamma(\frac{5}{6}) \Gamma(i + 1) (4\rho^{\frac{1}{3}})^i},$$

which when i is very large becomes by the transformations employed in Art. 7, very nearly,

$$\sqrt{\frac{2\pi}{i}} \left(\frac{i}{e}\right)^i \div \Gamma(\frac{1}{6}) \Gamma(\frac{5}{6}) (4\rho^{\frac{1}{3}})^i.$$

Denoting this expression by μ_i , and putting for $\Gamma(\frac{1}{6}) \Gamma(\frac{5}{6})$ its value $\pi \operatorname{cosec} \frac{\pi}{6}$ or 2π , we have

$$\mu_i = (2\pi i)^{-\frac{1}{2}} \frac{i^i}{(4\rho^{\frac{1}{3}} e)^i}; \dots\dots\dots (23)$$

whence for very large values of i

$$\frac{\mu_{i+1}}{\mu_i} = \frac{i}{4\rho^{\frac{1}{3}}} \dots\dots\dots (24)$$

For large values of ρ the moduli of several consecutive terms are nearly equal at the part of the series where the modulus is a minimum, and for the minimum modulus μ we have very nearly from (24), (23)

$$i = 4\rho^{\frac{1}{3}}, \quad \mu = (2\pi i)^{-\frac{1}{2}} e^{-i} = (2\pi i)^{-\frac{1}{2}} e^{-4\rho^{\frac{1}{3}}}.$$

If the exponential in the expression for μ be multiplied by the modulus of the exponential in the superior term, the result will be

$$e^{-(4 \mp 2 \cos \frac{2}{3} \theta) \rho^{\frac{1}{3}}}$$

the sign $-$ or $+$ being taken according as $\cos \frac{2}{3} \theta$ is positive or negative. Hence even if the terms of the divergent series were all positive, the superior term would be defined by means of its series within a quantity incomparably smaller, when ρ is indefinitely increased, than the inferior term, except only when $\pm \cos \frac{2}{3} \theta = 1$, and in this case too and this alone are the terms of the divergent series in the superior term regularly positive. In no other case then

can the coefficient of the inferior term alter discontinuously, and the coefficient of the other term cannot change so long as that term remains the superior term. Referring for convenience to the figure (Fig. 1), we see that it is only at the points a , b , c , at the middle of the portions of the curve which lie within the circle, that the coefficient belonging to the curve can change.

It might appear at first sight that we could have three distinct coefficients, corresponding respectively to the portions aAb , bBc , cCa of the curve, which would make three distinct constants occurring in the integral of a differential equation of the second order only. This however is not the case; and if we were to assign in the first instance three distinct constants to those three portions of the curve, they would be connected by an equation of condition.

To shew this assume the coefficient belonging to the part of the curve about B to be equal to zero. We shall thus get an integral of our equation with only one arbitrary constant.

Since there is no superior term from $\theta = -\frac{\pi}{3}$ to $\theta = +\frac{\pi}{3}$, the coefficient of the other term cannot change discontinuously at a (*i.e.* when θ passes through the value zero); and by what has been already shewn the coefficient must remain unchanged throughout the portion bBc of the curve, and therefore be equal to zero; and again the coefficient must remain unchanged throughout the portion $cCaAb$, and therefore have the same value as at a ; but these two portions between them take in the whole curve. The integral at present under consideration is represented by Fig. 2, the coefficient having the same value throughout the portion of the curve there drawn, and being equal to zero for the remainder of the course*.

The second line on the right-hand side of (20) is what the first becomes when the origin of θ is altered by $\pm\frac{2}{3}\pi$, and the arbitrary constant changed. Hence if we take the term corresponding to the curve represented in Fig. 3, and having a constant coefficient throughout the portion there represented, we shall get another particular integral with one arbitrary constant, and the sum of these two particular integrals will be the complete integral.

In Fig. 3 the uninterrupted interior branch of the curve is made to lie in the interval $\frac{\pi}{3}$ to π . It would have done

equally well to make it lie in the interval $-\frac{\pi}{3}$ to $-\pi$; we should thus in fact obtain the same complete integral merely somewhat differently expressed.

Fig. 2.

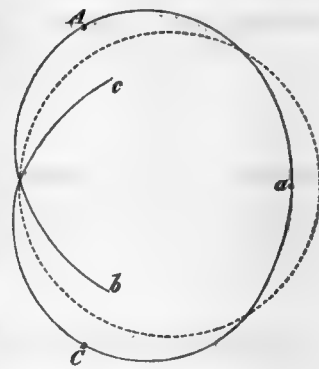
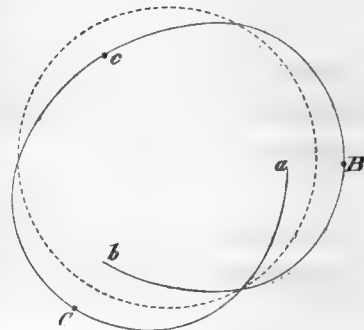

Fig. 3.



* A numerical verification of the discontinuity here represented is given as an Appendix to this paper.

The integral (20) may now be conveniently expressed in the following form, in which the discontinuity of the constants is exhibited :

$$u = \left(-\frac{4\pi}{3} \theta + \frac{4\pi}{3} \right) C x^{-\frac{1}{2}} e^{-2x^2} \left\{ 1 - \frac{1.5}{1.144x^{\frac{2}{3}}} + \frac{1.5.7.11}{1.2.144^2 x^3} - \dots \right\} \\ + \left(-\frac{2\pi}{3} \theta + 2\pi \right) D x^{-\frac{1}{2}} e^{2x^2} \left\{ 1 + \frac{1.5}{1.144x^{\frac{2}{3}}} + \frac{1.5.7.11}{1.2.144^2 x^3} + \dots \right\} \dots\dots\dots (25)$$

In this equation the expression $\left(-\frac{4\pi}{3} \theta + \frac{4\pi}{3} \right)$ denotes that the function written after it is to be taken whenever an angle in the indefinite series

$$\dots \theta - 4\pi, \quad \theta - 2\pi, \quad \theta, \quad \theta + 2\pi, \quad \theta + 4\pi, \dots$$

falls within the specified limits, which will be either once or twice according to the value of θ .

17. If we put $D = 0$ in (25), the resulting value of u will be equal to Mr Airy's integral, multiplied by an arbitrary constant, x being equal to $-\left(\frac{\pi}{2}\right)^{\frac{2}{3}} \frac{m}{3}$. When $\theta = 0$ we have the integral belonging to the dark side of the caustic, when $\theta = \pi$ that belonging to the bright side. We easily see from (25), or by referring to Fig. 2, in what way to pass from one of these integrals to the other, the integrals being supposed to be expressed by means of the divergent series. If we have got the analytical expression belonging to the dark side we must add $+\pi, -\pi$ in succession to the amplitude of x , and take the sum of the results. If we have got the analytical expression belonging to the bright side, we must alter the amplitude of x by π , and reject the superior function in the resulting expression. It is shewn in Art. 9 of my paper "On the Numerical Calculation, &c." that the latter process leads to a correct result, but I was unable then to give a demonstration. This desideratum is now supplied.

18. It now only remains to connect the constants A, B with C, D in the two different forms (19) and (25) of the integral of (18). This may be done by means of the complete integral of (18) expressed in the form of definite integrals.

Let
$$v = \int_0^\infty e^{-\lambda^3 - c\lambda} d\lambda,$$

then
$$\frac{d^2 v}{dx^2} = \frac{c^2}{3} \int_0^\infty e^{-\lambda^3 - c\lambda} \{ (3\lambda^2 + cx) - cx \} d\lambda \\ = \frac{c^2}{3} - \frac{c^3}{3} v;$$

whence

$$\frac{d^2 cv}{dx^2} + \frac{c^3}{3} x \cdot cv = \frac{c^3}{3} \dots\dots\dots (26)$$

In order to make the left-hand member of this equation agree with (18), we must have $c^3 = -27$, and therefore

$$c = -3, \text{ or } 3\alpha, \text{ or } 3\beta,$$

α, β being the imaginary cube roots of -1 , of which α will be supposed equal to

$$\cos \frac{\pi}{3} + \sqrt{-1} \sin \frac{\pi}{3}.$$

Whichever value of c be taken, the right-hand member of equation (26) will be equal to -9 , and therefore will disappear on taking the difference of any two functions cv corresponding to two different values of c . This difference multiplied by an arbitrary constant will be an integral of (18), and accordingly we shall have for the complete integral

$$u = E \int_0^\infty e^{-\lambda^3} (e^{3\alpha\lambda} + \alpha e^{-3\alpha\lambda}) d\lambda + F \int_0^\infty e^{-\lambda^3} (e^{3\beta\lambda} + \beta e^{-3\beta\lambda}) d\lambda \dots \dots \dots (27)$$

That this expression is in fact equivalent to (19) might be verified by expanding the exponentials within parentheses, and integrating term by term.

To find the relations between E, F and A, B , it will be sufficient to expand as far as the first power of x , and equate the results. We thus get

$$A + Bx = \int_0^\infty e^{-\lambda^3} \{ (1 + \alpha)E + (1 + \beta)F + 3 [(1 - \alpha^2)E + (1 - \beta^2)F] x \lambda \} d\lambda$$

which gives, since

$$\begin{aligned} \alpha^2 &= -\beta, \quad \beta^2 = -\alpha, \quad \int_0^\infty e^{-\lambda^3} d\lambda = \frac{1}{3} \Gamma\left(\frac{1}{3}\right), \quad \int_0^\infty e^{-\lambda^3} \lambda d\lambda = \frac{1}{3} \Gamma\left(\frac{2}{3}\right), \\ A &= \frac{1}{3} \Gamma\left(\frac{1}{3}\right) \{ (1 + \alpha)E + (1 + \beta)F \}, \\ B &= \Gamma\left(\frac{2}{3}\right) \{ (1 + \beta)E + (1 + \alpha)F \}. \end{aligned} \dots \dots \dots (28)$$

19. We have now to find the relations between E, F and C, D , for which purpose we must compare the expressions (25), (27), supposing x indefinitely large.

In order that the exponentials in (25), may be as large as possible, we must have $\theta = \frac{2\pi}{3}$ in the term multiplied by C , and $\theta = 0$ in the term multiplied by D . We have therefore for the leading term of u

$$\begin{aligned} C e^{-\frac{\pi}{6}\sqrt{-1}} \rho^{-\frac{1}{2}} e^{2\theta \frac{3}{2}}, \quad \text{when } \theta = \frac{2\pi}{3}; \\ D \rho^{-\frac{1}{2}} e^{2\theta \frac{3}{2}}, \quad \text{when } \theta = 0. \end{aligned}$$

Let us now seek the leading term of u from the expression (27), taking first the case in which $\theta = 0$. It is evident that this must arise from the part of the integral which involves $e^{3\alpha\lambda}$ or in this case $e^{3\rho\lambda}$, which is

$$(E + F) \int_0^\infty e^{-\lambda^3 + 3\rho\lambda} d\lambda.$$

Now $3\rho\lambda - \lambda^3$ is a maximum for $\lambda = \rho^{\frac{1}{3}}$. Let $\lambda = \rho^{\frac{1}{3}} + \zeta$; then

$$3\rho\lambda - \lambda^3 = 2\rho^{\frac{2}{3}} - 3\rho^{\frac{1}{3}}\zeta^2 - \zeta^3,$$

and our integral becomes

$$e^{2\rho^{\frac{2}{3}}} \int_{-\rho^{\frac{1}{3}}}^{\infty} e^{-3\rho^{\frac{1}{3}}\zeta^2 - \zeta^3} d\zeta.$$

Put $\zeta = 3^{-\frac{1}{3}}\rho^{-\frac{1}{3}}\xi$; then the integral becomes

$$3^{-\frac{1}{2}}\rho^{-\frac{1}{2}}e^{2\rho^{\frac{2}{3}}} \int_{-3^{\frac{1}{3}}\rho^{\frac{1}{3}}}^{\infty} e^{-\xi^2 - 3^{-1}\rho^{-\frac{2}{3}}\xi^3} d\xi.$$

Let now ρ become infinite; then the last integral becomes $\int_{-\infty}^{\infty} e^{-\xi^2} d\xi$ or $\pi^{\frac{1}{2}}$. For though the index $-\xi^2 - 3^{-1}\rho^{-\frac{2}{3}}\xi^3$ becomes positive for a sufficiently large negative value of ξ , that value lies far beyond the limits of integration, within which in fact the index continually decreases with ξ , having at the inferior limit the value $-2\rho^{\frac{2}{3}}$. Hence then for $\theta = 0$, and for very large values of ρ , we have ultimately

$$u = 3^{-\frac{1}{2}}\pi^{\frac{1}{2}}(E + F)\rho^{-\frac{1}{2}}e^{2\rho^{\frac{2}{3}}}.$$

Next let $\theta = \frac{2\pi}{3}$. In this case $a\omega = -\rho$, and we get for the leading part of u

$$aE \int_0^{\infty} e^{-\lambda^3 + 3\rho\lambda} d\lambda,$$

which when ρ is very large becomes, as before,

$$3^{-\frac{1}{2}}\pi^{\frac{1}{2}}aE\rho^{-\frac{1}{2}}e^{2\rho^{\frac{2}{3}}}.$$

Comparing the leading terms of u both for $\theta = \frac{2\pi}{3}$ and for $\theta = 0$, we find, observing that $a = e^{\frac{\pi}{3}\sqrt{-1}}$

$$\left. \begin{aligned} C &= \sqrt{-1} 3^{-\frac{1}{2}}\pi^{\frac{1}{2}}E, \\ D &= 3^{-\frac{1}{2}}\pi^{\frac{1}{2}}(E + F). \end{aligned} \right\} \dots\dots\dots (29)$$

Eliminating E, F between (28) and (29) we have finally

$$\left. \begin{aligned} A &= \pi^{-\frac{1}{2}}\Gamma\left(\frac{1}{3}\right) \{ C + e^{-\frac{\pi}{6}\sqrt{-1}} D \}, \\ B &= 3\pi^{-\frac{1}{2}}\Gamma\left(\frac{2}{3}\right) \{ -C + e^{\frac{\pi}{6}\sqrt{-1}} D \}. \end{aligned} \right\} \dots\dots\dots (30)$$

20. As a last example of the principles of this paper, let us take the differential equation

$$\frac{d^2u}{dx^2} + \frac{1}{x} \frac{du}{dx} - u = 0. \dots\dots\dots (31)$$

The complete integral of this equation in series according to ascending powers of x involves a logarithm. If the arbitrary constant multiplying the logarithm be equated to zero we shall obtain an integral with only one arbitrary constant. This integral, or rather what it becomes

when $\sqrt{-1} x$ is written for x , occurs in many physical investigations, for example the problem of annular waves in shallow water, and that of diffraction in the case of a circular disk. I had occasion to employ the integral with a logarithm in determining the motion of a fluid about a long cylindrical rod oscillating as a pendulum, the internal friction of the fluid itself being taken into account*. In that paper the integral of (31) both in ascending and in descending series was employed, but the discussion of the equation was not quite completed, one of the arbitrary constants being left undetermined. A knowledge of the value of this constant was not required for determining the resultant force of the fluid on the pendulum, which was the great object of the investigation, but would have been required for determining the motion of the fluid at a great distance from the pendulum.

21. The three forms of the integral of (31) which we shall require are given in Arts. 28 and 29 of my paper on pendulums. The complete integral according to ascending series is

$$u = (A + B \log x) \left(1 + \frac{x^2}{2^2} + \frac{x^4}{2^2 \cdot 4^2} + \frac{x^6}{2^2 \cdot 4^2 \cdot 6^2} + \dots \right) - B \left(\frac{x^2}{2^2} S_1 + \frac{x^4}{2^2 \cdot 4^2} S_2 + \frac{x^6}{2^2 \cdot 4^2 \cdot 6^2} S_3 + \dots \right) \dots\dots\dots (32)$$

where

$$S_i = 1^{-1} + 2^{-1} + 3^{-1} \dots + i^{-1}.$$

The series contained in this equation are convergent for all real or imaginary values of x , but the value of u determined by the equation is not unique, inasmuch as $\log x$ has an infinite number of values. To pass from one of these to another comes to the same thing as changing the constant A by some multiple of $2\pi B\sqrt{-1}$. If ρ, θ , the modulus and amplitude of x , be supposed to be polar co-ordinates, and the expression (32) be made to vary continuously by giving continuous variations to ρ and θ without allowing the former to vanish, the value of $\log x$ will increase by $2\pi\sqrt{-1}$ in passing from any point in the positive direction once round the origin so as to arrive at the starting point again. In order to render everything definite we must specify the value of the logarithm which is supposed to be taken.

The complete integral of (31) expressed by means of descending series is

$$u = Cx^{-\frac{1}{2}}e^{-x} \left\{ 1 - \frac{1^2}{2 \cdot 4x} + \frac{1^2 \cdot 3^2}{2 \cdot 4 (4x)^2} - \frac{1^2 \cdot 3^2 \cdot 5^2}{2 \cdot 4 \cdot 6 (4x)^3} + \dots \right\} + Dx^{-\frac{1}{2}}e^x \left\{ 1 + \frac{1^2}{2 \cdot 4x} + \frac{1^2 \cdot 3^2}{2 \cdot 4 (4x)^2} + \frac{1^2 \cdot 3^2 \cdot 5^2}{2 \cdot 4 \cdot 6 (4x)^3} + \dots \right\} \dots\dots\dots (33)$$

These series are ultimately divergent, and the constants C, D are discontinuous. It may be shewn precisely as before that the values of θ for which the constants are discontinuous are

$$\dots - 4\pi, \quad - 2\pi, \quad 0, \quad 2\pi, \quad 4\pi \dots \text{ for } C, \\ \dots - 3\pi, \quad - \pi, \quad \pi, \quad 3\pi, \dots \text{ for } D.$$

* *Camb. Phil. Trans.* Vol. IX. Part II. p. [38.]

Hence the equation (33) may be written, according to the notation employed in Art. 16, as follows :

$$u = (0 \text{ to } 2\pi) Cx^{-\frac{1}{2}}e^{-x} \left(1 - \frac{1^2}{2 \cdot 4x} + \dots\right) + (-\pi \text{ to } +\pi) Dx^{-\frac{1}{2}}e^x \left(1 + \frac{1^2}{2 \cdot 4x} + \dots\right) \dots\dots (34)$$

22. It remains to connect *A, B* with *C, D*. For this purpose we shall require the third form of the integral of (31), namely

$$u = \int_0^{\frac{\pi}{2}} \{E + F \log(x \sin^2 \omega)\} (e^{x \cos \omega} + e^{-x \cos \omega}) d\omega \dots\dots\dots (35)$$

As to the value of $\log x$ to be taken, it will suffice for the present to assume that whatever value is employed in (32), the same shall be employed also in (35).

To connect *A, B* with *E, F*, it will be sufficient to compare (32) and (35), expanding the exponentials, and rejecting all powers of *x*. We have

$$\begin{aligned} A + B \log x &= 2 \int_0^{\frac{\pi}{2}} \{E + F \log(x \sin^2 \omega)\} d\omega \\ &= \pi (E + F \log x) + 2\pi \log\left(\frac{1}{2}\right) \cdot F; \end{aligned}$$

whence

$$\left. \begin{aligned} A &= \pi E - 2\pi \log 2 \cdot F, \\ B &= \pi F. \end{aligned} \right\} \dots\dots\dots (36)$$

To connect *C, D* with *E, F*, we must seek the ultimate value of *u* when ρ is infinitely increased. It will be convenient to assume in succession $\theta = 0$ and $\theta = \pi$. We have ultimately from (34)

$$u = D\rho^{-\frac{1}{2}}e^\rho \text{ when } \theta = 0; \quad u = -\sqrt{-1} C\rho^{-\frac{1}{2}}e^\rho \text{ when } \theta = \pi \dots\dots (37)$$

It will be necessary now to specify what value of $\log x$ we suppose taken in (35). Let it be $\log \rho + \sqrt{-1}\theta$, θ being supposed reduced within the limits 0 and 2π by adding or subtracting if need be $2i\pi$, where *i* is an integer.

The limiting value of *u* for $\theta = 0$ from (35) may be found as in Art. 29 of my paper on Pendulums, above referred to. In fact, the reasoning of that Article will apply if the imaginary quantity there denoted by *m* be replaced by unity. The constants

$$C, D, C', D', C'', D'',$$

of the former paper correspond to

$$A, B, C, D, E, F,$$

of the present. Hence we have for the ultimate value of *u* for $\theta = 0$

$$u = \left(\frac{\pi}{2\rho}\right)^{\frac{1}{2}} e^\rho \{E + (\pi^{-\frac{1}{2}}\Gamma'(\frac{1}{2}) + \log 2) F\}. \dots\dots\dots (38)$$

For $\theta = \pi$, (35) becomes

$$u = \int_0^{\frac{\pi}{2}} \{E + \pi F \sqrt{-1} + F \log(\rho \sin^2 \omega)\} (e^{-\rho \cos \omega} + e^{\rho \cos \omega}) d\omega;$$

and to find the ultimate value of *u* we have merely to write $E + \pi F \sqrt{-1}$ for *E* in the above, which gives ultimately for $\theta = \pi$

$$u = \left(\frac{\pi}{2\rho}\right)^{\frac{1}{2}} e^\rho [E + \pi F \sqrt{-1} + \{\pi^{-\frac{1}{2}}\Gamma'(\frac{1}{2}) + \log 2\} F]. \dots\dots\dots (39)$$

Comparing the equations (38), (39) with (37), we get

$$\left. \begin{aligned} C &= \left(\frac{\pi}{2}\right)^{\frac{1}{2}} [E \sqrt{-1} - \pi F + \{\pi^{-\frac{1}{2}} \Gamma'(\frac{1}{2}) + \log 2\} \sqrt{-1} F], \\ D &= \left(\frac{\pi}{2}\right)^{\frac{1}{2}} [E + \{\pi^{-\frac{1}{2}} \Gamma'(\frac{1}{2}) + \log 2\} F]. \end{aligned} \right\} \dots\dots\dots (40)$$

Eliminating E, F between (36) and (40), we get finally

$$\left. \begin{aligned} C &= (2\pi)^{-\frac{1}{2}} [\sqrt{-1} A + \{(\pi^{-\frac{1}{2}} \Gamma'(\frac{1}{2}) + \log 8) \sqrt{-1} - \pi\} B], \\ D &= (2\pi)^{-\frac{1}{2}} [A + \{\pi^{-\frac{1}{2}} \Gamma'(\frac{1}{2}) + \log 8\} B]. \end{aligned} \right\} \dots\dots\dots (41)$$

Conclusion.

23. It has been shewn in the foregoing paper,

First, That when functions expressible in convergent series according to ascending powers of the variable are transformed so as to be expressed by exponentials multiplied by series according to descending powers, applicable to the calculation of the functions for large values of the variable, and ultimately divergent, though at first rapidly convergent, the series contain in general discontinuous constants, which change abruptly as the amplitude of the imaginary variable passes through certain values.

Secondly, That the liability to discontinuity in one of the constants is pointed out by the circumstance, that for a particular value of the amplitude of the variable, all the terms of an associated divergent series become regularly positive.

Thirdly, That a divergent series with all its terms regularly positive is in many cases a sort of indeterminate form, in passing through which a discontinuity takes place.

Fourthly, That when the function may be expressed by means of a definite integral, the constants in the ascending and descending series may usually be connected by one uniform process. The comparison of the leading terms of the ascending series with the integral presents no difficulty. The comparison of the leading terms of the descending series with the integral may usually be effected by assigning to the amplitude of the variable such a value, or such values in succession, as shall render the real part of the index of the exponential a maximum, and then seeking what the integral becomes when the modulus of the variable increases indefinitely. The leading term obtained from the integral will be found within a range of integration comprising the maximum value of the real part of the index of the exponential under the integral sign, and extending between limits which may be supposed to become indefinitely close after the modulus of the original variable has been made indefinitely great, whereby the integral will be reduced to one of a simpler form. Should a definite integral capable of expressing the function not be discovered, the relations between the constants in the ascending and descending series may still be obtained numerically by calculating from the ascending and descending series separately and equating the results.

APPENDIX.

[Added since the reading of the Paper.]

ON account of the strange appearance of figures 2 and 3, the reader may be pleased to see a numerical verification of the discontinuity which has been shewn to exist in the values of the arbitrary constants. I subjoin therefore the numerical calculation of the integral to which fig. 2 relates, for two values of x , from the ascending and descending series separately. For this integral $D = 0$, and I will take $C = 1$, which gives, (equations 30.)

$$A = \pi^{-\frac{1}{2}} \Gamma\left(\frac{1}{3}\right); \quad B = -3\pi^{-\frac{1}{2}} \Gamma\left(\frac{2}{3}\right);$$

$$\text{and } \log A = 0.1793878; \quad \log(-B) = 0.3602028.$$

The two values of x chosen for calculation have 2 for their common modulus, and 90° , 150° , respectively, for their amplitudes, so that the corresponding radii in fig. 2 are situated at 30° on each side of the radius passing through the point of discontinuity c . The terms of the descending series are calculated to 7 places of decimals. As the modulus of the result has afterwards to be multiplied by a number exceeding 40, it is needless to retain more than 6 decimal places in the ascending series. In the multiplications required after summation, 7-figure logarithms were employed. The results are given to 7 significant figures, that is, to 5 places of decimals.

The following is the calculation by ascending series for the amplitude 90° of x . By the first and second series are meant respectively those which have A, B for their coefficients in equation (19).

<i>First Series.</i>			<i>Second Series.</i>	
Order of term.	Real part.	Coefficient of $\sqrt{-1}$.	Real part.	Coefficient of $\sqrt{-1}$.
0	+ 1.000000			+ 2.000000
1		- 12.000000	+ 12.000000	
2	- 28.800000			- 20.571429
3		+ 28.800000	- 16.457143	
4	+ 15.709091			+ 7.595605
5		- 5.385974	+ 2.278681	
6	- 1.267288			- 0.479722
7		+ 0.217249	- 0.074762	
8	+ 0.028337			+ 0.008971
9		- 0.002906	+ 0.000855	
10	- 0.000240			- 0.000066
11		+ 0.000016	- 0.000004	
12	+ 0.000001			
Sum	- 13.330099	+ 11.628385 $\sqrt{-1}$	- 2.252373	- 11.446641 $\sqrt{-1}$
Sum multiplied by A ,	- 20.14750	+ 17.57548 $\sqrt{-1}$;	by B ,	+ 5.16230 + 26.23499 $\sqrt{-1}$.

When the amplitude of x becomes 150° in place of 90° , the amplitude of x^3 is increased by 180° . Hence in the first series it will be sufficient to change the sign of the imaginary part. To see what the second series becomes, imagine for a moment the factor x put outside as a coefficient. In the reduced series it would be sufficient to change the sign of the imaginary part; and to correct for the change in the factor x it would be sufficient to multiply by $\cos 60^\circ + \sqrt{-1} \sin 60^\circ$. But since the amplitude of x was at first 90° , the real and imaginary parts of the series calculated correspond respectively to the imaginary and real parts of the reduced series. Hence it will be sufficient to change the sign of the real part in the product of the sum of the second series by B , and multiply by $\frac{1}{2}(1 + \sqrt{3}\sqrt{-1})$, which gives the result

$$- 25.30132 + 8.64681 \sqrt{-1}.$$

Hence we have for the result obtained from the ascending series:

	for amp. $x = 90^\circ$,	for amp. $x = 150^\circ$,
From first series	$- 20.14750 + 17.57548 \sqrt{-1}$	$- 20.14750 - 17.57548 \sqrt{-1}$
From second series	$+ 5.16230 + 26.23499 \sqrt{-1}$	$- 25.30132 + 8.64681 \sqrt{-1}$
Total	$- 14.98520 + 43.81047 \sqrt{-1}$	$- 45.44882 - 8.92867 \sqrt{-1}$

On account of the particular values of amp. x chosen for calculation, the terms in the ascending series were either wholly real or wholly imaginary. In the case of the descending series this is only true of every second term, and therefore the values of the moduli are subjoined in order to exhibit their progress. The following is the calculation for amp. $x = 90^\circ$, in which case there is no inferior term.

Order.	Modulus.	Real part.	Coefficient of $\sqrt{-1}$.
0	1.0000000	+ 1.0000000	
1	0.0122762	+ 0.0086806	+ 0.0086806
2	0.0011604		+ 0.0011604
3	0.0002099	- 0.0001484	+ 0.0001484
4	0.0000563	- 0.0000563	
5	0.0000200	- 0.0000142	- 0.0000142
6	0.0000089		- 0.0000089
7	0.0000047	+ 0.0000033	- 0.0000033
8	0.0000029	+ 0.0000029	
9	0.0000021	+ 0.0000015	+ 0.0000015
10	0.0000017		+ 0.0000017
11	0.0000015	- 0.0000010	+ 0.0000010
Remainder		- 0.0000007	- 0.0000017
Sum		+ 1.0084677	+ 0.0099655 $\sqrt{-1}$.

The modulus of the term of the order 12 is 14 in the seventh place, and is the least of the moduli. Those of the succeeding terms are got by multiplying the above by the factors

1.0616, 1.2208, 1.5116, 2.0053, &c., and the successive differences of the series of factors headed by unity are

$$\Delta^1 = + 0.0616, \Delta^2 = + 0.0976, \Delta^3 = + 0.0340, \Delta^4 = + 0.0373, \&c.$$

These differences when multiplied by 14 are so small that in the application of the transformation of Art. 8, for which in the present case $q = 1$, the differences may be neglected, and the series there given reduced to its first term. It is thus that the remainder given above was calculated.

The sum of the series is now to be reduced to the form $\rho (\cos \theta + \sqrt{-1} \sin \theta)$, and thus multiplied by $e^{-2\pi^2}$ and by $x^{-\frac{1}{2}}$. We have

for series	log. mod. = 0.0036832	amp. = +	0° 33' 58". 21
for exponential	log. mod. = 1.7371779	amp. = +	130° 49' 0". 78
for $x^{-\frac{1}{2}}$	log. mod. = 1.9247425	amp. = -	22° 30'
	1.6656036		+ 108° 52' 58". 99

When the amplitude of x is 150° , there are both superior and inferior terms in the expression of the function by means of descending series. It will be most convenient, as has been explained, to put in succession, in the function multiplied by C in equation (20), amp. $x = 150^\circ$ and amp. $x = -210^\circ$, and to take the sum of the results. The first will give the superior, the second the inferior term.

For the amplitudes $90^\circ, 150^\circ$ of x , or more generally for any two amplitudes equidistant from 120° , the amplitudes of $x^{\frac{2}{3}}$ will be equidistant from 180° , so that for any rational and real function of $x^{\frac{2}{3}}$ we may pass from the result in the one case to the result in the other by simply changing the sign of $\sqrt{-1}$, or, which comes to the same, changing the sign of the amplitude of the result. The series and the exponential are both such functions, and for the factor $x^{-\frac{1}{2}}$ we have simply to replace the amplitude $-22^\circ 30'$ by $-37^\circ 30'$. Hence we have for the superior term

$$\text{log. mod.} = 1.6656036; \text{ amp.} = -168^\circ 52' 58". 99.$$

When amp. x is changed from 150° to -210° , amp. $x^{\frac{2}{3}}$ is altered by $3 \times 180^\circ$, and therefore the sign of $x^{\frac{2}{3}}$ is changed. Hence the log. mod. of the exponential is less than it was by $2 \times 1.737\dots$ or by more than 3. Hence 4 decimal places will be sufficient in calculating the series, and 4-figure logarithms may be employed in the multiplications. The terms of the series will be obtained from those already calculated by changing first the signs of the imaginary parts, and secondly the sign of every second term, or, which comes to the same, by changing the signs of the real parts in the terms of the orders 1, 3, 5..., and of the imaginary parts in the terms of the orders 0, 2, 4... Hence we have

Real part.	Coefficient of $\sqrt{-1}$.
+ 1.0000	
- 0.0087	+ 0.0087
	- 0.0012
+ 0.0001	+ 0.0001
+ 0.9914	+ 0.0076 $\sqrt{-1}$
log. mod. = 1.9963; amp. = + 26'. 5.	

Hence we have altogether for the inferior term,

$$\log. \text{ mod.} = \bar{2}.1838; \text{ amp.} = + 183^{\circ} 45'.5$$

Hence reducing each imaginary result from the form $\rho (\cos \theta + \sqrt{-1} \sin \theta)$ to the form $a + \sqrt{-1} b$, we have for the final result, obtained from the descending series:

For amp. $x = 90^{\circ}$.	For amp. $x = 150^{\circ}$.
From superior term $- 14.98520 + 43.81046 \sqrt{-1}$;	$- 45.43360 - 8.92767 \sqrt{-1}$
From inferior term	$- 0.01524 - 0.00100 \sqrt{-1}$
	$- 45.44884 - 8.92867 \sqrt{-1}$

Had the asserted discontinuity in the value of the arbitrary constant not existed, either the inferior term would have been present for amp. $x = 90^{\circ}$, or it would have been absent for amp. $x = 150^{\circ}$, and we see that one or other of the two results would have been wrong in the second place of decimals.

In considering the relative difficulty of the calculation by the ascending and descending series, it must be remembered that the blanks only occur in consequence of the special values of the amplitude of x chosen for calculation: for general values they would have been all filled up by figures. Hence even for so low a value of the modulus of x as 2 the descending series have a decided advantage over the ascending.



VII. *On the Beats of Imperfect Consonances.* By AUGUSTUS DE MORGAN, F.R.A.S.
of Trinity College, Professor of Mathematics in University College, London.

[Read Nov. 9, 1857.]

THE subject of this paper was treated in full, for the first and only time, by Dr Robert Smith, in the two editions of his *Harmonics* (Cambridge, 1749, 8vo.; London*, 1759, 8vo.). The results are the same in both editions, but the improvements of the second edition add considerably to the learned obscurity in which the subject is involved. Dr Smith presents, so far as I know, the strongest union of the scholar, mathematician, physical philosopher, and practical musician, who ever treated of mathematical harmonics: and his book is not only the most obscure and repulsive in its own subject, but it would be difficult to match it in any subject. The consequence has been that the point in which Robert Smith made an important addition to acoustics has been little more than a result† in the hands of some of the organ-tuners. Dr Young certainly did not understand Smith's theory. He was also a remarkable union of the scholar, mathematician (a character in which he deserves to stand much higher than he is usually placed), and physical philosopher: and was a successful student in music; but he wanted a musical ear (Peacock's *Life*, pp. 59, 79, 81). I have my doubts whether Robison had read more of Smith's theory than its results. For myself, I made out what ought to have been the theory from the *formulæ*, and then was successful in mastering Smith's explanations.

Before proceeding to the subject, I make some remarks upon the method of dividing the octave. Should this paper fall into the hands of any mathematician unused to musical *measurement*, he must be informed that proximity and longinquity are measured by *ratio*, not by *difference*. Thus notes of p and q vibrations per second are at the same interval as notes of kp and kq vibrations per second, be k what it may. Consequently, an interval remains constant, not with $p - q$, but with $\log p - \log q$. The *octave* of any note, which has with that note a sort of identity of effect which no words can describe, makes two vibrations while the note makes one vibration. Any note makes p vibrations while its upper octave makes $2p$ vibrations: hence $\log 2p - \log p$, or $\log 2$, is the measure of every interval of an octave.

* It is worthy of note that at this period the book bears the name of the place where it is *printed*, not of the place where the *publisher* sells it. Both these editions are printed for Cambridge publishers (the Merrills).

† So long as unequal temperament was in use, and even

now when it is adopted, the *beats* were and sometimes are used in tuning: but when equal temperament is required (and this system has gained ground rapidly) the tuners have nothing to do with beats, except to get perfect octaves by destroying them. I speak of the organ, and of this country.

Many writers, from Sauveur downwards, have seen the convenience of using the figures of $\cdot 3010300$, the common* logarithm of 2. Thus Sauveur, for one method, divides the octave into 301 parts, so that if the higher of two notes make m vibrations while the lower makes n , the integer in 1000 ($\log m - \log n$) is the number of subdivisions contained in the interval, *quam proximè*. The tuner of the pianoforte is required to estimate half a subdivision: for the fifth of equal temperament is 175·60 subdivisions, and the perfect fifth is 176·09 subdivisions. Even in practice, then, a smaller subdivision is required: and theory will hardly be content without the representation of the 50th part of the smallest interval in common practical use. I should propose to divide the octave into 30103 equal parts, 2508·6 to a mean semitone. Each part may be called an *atom*; and we have the following easy rules, which suppose the use of a table of five-figure logarithms.

To find the number of atoms in the interval from m to n vibrations per second, neglect the decimal point in $\log m - \log n$, or in $\log n - \log m$, whichever is positive. To find the ratio of the numbers of vibrations in an interval of k atoms, divide by 100,000, and find the primitive to the result as a logarithm.

To find the number of mean semitones in a number of atoms, divide the number of atoms by $\frac{1}{12} \log 2 \times 100000$, which may be done thus. Multiply by four; deduct the 300th part of this product and its 10,000th part, adding one-ninth of this 10,000th part; make four decimal places, and rely on three. Thus a perfect fifth has 100,000 ($\log 3 - \log 2$) atoms, or 17609, which multiplied by 4 is 70436. The 300th part of this is 235, and the 10,000th part is 7, of which one-ninth may be called 1. And 70436 - 241 is 70195, whence 7·0195, say 7·020, is the number of mean semitones in a perfect fifth.

To find the atoms in a number of mean semitones, multiply by 10,000; add to the result its 300th part and its 10,000th part, and divide by 4. Thus 12 mean semitones gives 120,000 increased by 400 + 12, or 120412, which divided by 4 gives 30103. This rule is as accurate as the value of $\log 2$; the one which precedes is a near approximation. Both are consequences of the equation

$$\frac{1}{12} \times \cdot 30103 = \frac{1}{40} \left(1 + \frac{1}{300} + \frac{1}{10,000} \right).$$

Dr Smith found that the D of his organ, the first space below the lines of the treble, gave 254, 262, 268, double vibrations † in the common temperatures of November, September, and August.

* Euler, and after him Lambert, suggested the use of *acoustical* logarithms; and proposed systems, of which the bases are 2 and $\sqrt[12]{2}$. Prony gave both tables in his *Instructions Élémentaires sur les moyens de calculer les intervalles musicaux*, Paris, 1832, 4to. The second table shows at once, in $\log m - \log n$, the number of mean semitones in the interval whose ratio of vibrations is $m : n$. Prony has also calculated, but I cannot give the reference, a table of logarithms to the base $\frac{81}{80}$, which gives the number of *commas* in $m : n$, by $\log m - \log n$.

The *atom* which I have proposed, which is the 540th part of a comma, gives the commas by division by 60 and 9. I have my doubts whether any tables will be so convenient as those of common logarithms, used in the way I propose. Special tables,

for purposes which do not often occur, are of value only when they save complicated operations. Such tables are not in the way when wanted; and when they are found, their structure and rationale have to be remembered.

It is a sufficient proof of the state of knowledge of the theory of beats that a work which goes so deeply into the formulæ connected with musical vibrations as Prony's makes no allusion to beats. Previously to the use of logarithms, the arithmetical calculations of the scale were very laborious. Mersenne makes $58\frac{1}{2}$ commas in the octave, the true number being $55\frac{1}{2}$. Nicolas Mercator corrected this in a manuscript seen by Dr Holder, and then proposed an artificial comma of 53 to the octave, which gave all the intervals very nearly integer.

† Writers are very obscure in their use of the word *vibra-*

Here we have intervals of $\cdot 54$ and $\cdot 39$, altogether $\cdot 93$, of a mean semitone. Mr Woolhouse's experiment gives 254 double vibrations to the C immediately below; and other experiments give nearly the same, for our day. The common tradition is that concert-pitch has risen about a note in the last century. The change can be traced in its progress. Robison, at the end of the last century, found the ordinary tuning-forks gave 240 vibrations for C, that is, 270 vibrations for D, a little higher than Dr Smith's organ at its warmest. Possibly some of this effect may have arisen as follows. The organs being tuned in the cold to the usual pitch of the day, the orchestras, on tuning with them after the air had been warmed by a crowd, would find it necessary to raise their pitch. This would have a tendency to cause a permanent rise, which the organ-tuners would of course follow, and then the same effect would be repeated. The convenience of representing the Cs-by powers of 2 has led many writers to choose 256 as the number of double vibrations in the first C below the lines of the treble: I trust this power of 2 will be enough to prevent the pitch from making any further ascent.

The subject to which I now come has been perplexed from the beginning by a confusion of different things under one word. By a *beat*, I mean any acoustical cycle derived from composition of ordinary vibrations; whether the returns can be distinguished by the ear as separate occurrences, or whether they are rapid enough to cause a sound. The first kind* of beats were used by Sauveur: but as there is a confused discussion about them in which his name occurs, it will be more convenient to call them *Tartini's beats*, because, when they become rapid enough to give a note, that note is the *grave harmonic* detected by Tartini in or

tion; they make it difficult to know whether they mean the single wave, be it of condensation or of rarefaction, or the double wave made up of one condensation and one rarefaction. Much confusion might have been saved in many subjects if terms of contempt, or of slang, had been seriously adopted: for such terms are very often more expressive than the solemn words which they are directed at. The "previous examination" is very feeble compared with the "little-go." For the present case, when the pendulum was brought into use, it was called in derision a *swing-swang*. If this word had been adopted by writers on acoustics, all the confusion I speak of would have been prevented; for no writer would have left it in doubt whether he reckoned in *swings*, or in *swing-swangs*, as I shall do. There is the same difficulty in medical descriptions, occasionally: some have counted inspiration and respiration as one, most as two.

* The organ tuners must in all time have known the beats which disappear when the concord becomes perfect. The first writer who is cited as having mentioned them is Mersenne (*Harmonie Universelle*, Paris, 1636, folio, book on instruments, p. 362). But Mersenne does not attempt any explanation. He observes that two pipes which are nearly unisons *tremble*, and make the hand which holds them tremble. But the trembling goes off when the unison is made perfect; which, says Mersenne, is the exact opposite of what takes place in strings. That is, he imagined the beats were to be compared with the sympathetic vibrations. Dr Smith, with that habit of indistinctive citation which is one of the manias of much learning, cites Mersenne and Sauveur together as his predecessors in the subject.

There is another writer who is better qualified to be classed

as the immediate predecessor of Sauveur, because he distinctly opposes the sympathy of consonant vibrations, and its effects, to the clashing of dissonant vibrations. I mean Dr Wm. Holder, F.R.S., who died in January 1696-7, and was the opponent of Wallis on a question of priority in the method of teaching the deaf and dumb. In his *Natural Grounds and Principles of Harmony*, published in 1694, he describes beats in a manner which is worth quoting, were it only as an instance of the poetry of explanation which science has driven out (pp. 34, 35, ed. of 1731):—

"It hath been a common Practice to imitate a Tabour and Pipe upon an Organ. Sound together two discording Keys (the base Keys will shew it best, because their Vibrations are slower), let them, for Example, be Gamut with Gamut sharp, or F Faut sharp, or all three together. Though these of themselves should be exceeding smooth and well voyced Pipes, yet, when struck together, there will be such a Battel in the Air between their disproportioned Motions, such a Clatter and Thumping, that it will be like the beating of a Drum, while a Jigg is played to it with the other hand. If you cease this, and sound a full Close of Concorde, it will appear surprizingly smooth and sweet Being in an Arched sounding Room near a shrill Bell of a House Clock, when the Alarm struck, I whistled to it, which I did with ease in the same Tune with the Bell, but, endeavouring to whistle a Note higher or lower, the Sound of the Bell and its cross Motions were so predominant, that my Breath and Lips were check'd, that I could not whistle at all, nor make any sound of it in that discording Tune. After, I sounded a shrill whistling Pipe, which was out of Tune to the Bell, and their Motions so clashed, that they seemed to sound like switching one another in the Air."

about 1714. And even when they give a sound, it will still be convenient to call them Tartini's beats. These beats are in their perfect theoretical existence when a consonance is quite true, and they owe their usual existence to its *approximate truth*. Tartini* used to tell his pupils that their thirds could not be in tune when they played or sang together, unless they heard the low note: assuming, doubtless, that their perceptions were as acute as his own.

The second kind of beats I shall call *Smith's beats*, because Dr Smith first made use of them, and gave their theory. They are entirely the consequence of the *imperfection* of a consonance, and become more rapid and more disagreeable as the imperfection increases, vanishing entirely when the consonance is perfectly true.

I cannot find the means of affirming that Smith was acquainted with Tartini's grave harmonic. In the place in which one would have expected him to mention it, namely, when he mentions the *flutterings*, as he calls them, which I name Tartini's beats, he does not make the slightest reference to those flutterings becoming rapid enough to yield a note, though he complains that he could hardly count them.

Smith accuses Sauveur of confounding the beats of an imperfect consonance with the flutterings† of a perfect one. It is true that Sauveur makes the same use of Tartini's beat

* Tartini published his treatise on harmony at Padua in 1754. D'Alembert's account of this work is so precisely what he might have written of Smith, that I quote it. "Son livre est écrit d'une manière si obscure, qu'il nous est impossible d'en porter aucun jugement: et nous apprenons que des Savans illustres en ont pensé de même. Il seroit à souhaiter que l'Auteur engageât quelque homme de lettres versé dans la Musique et dans l'art d'écrire, à développer des idées qu'il n'a pas rendues assez nettement, et dont l'art tireroit peut-être un grand fruit, si elles étoient mises dans le jour convenable." M. Romieu, of Montpellier, published a memoir in 1751, in which he described Tartini's grave harmonic: and hence some have made him the first discoverer. But Tartini had been teaching the violin, on which instrument he was the head of a celebrated school, a great many years: that he should not have published the grave harmonic to every pupil whom he taught to tune by fifths, is incredible. He himself affirms in his work that he always did so from 1728, when he established his school: and further, that he made the discovery on his violin, at Ancona, in 1714; this was the year after he dreamed the *Devil's Sonata*. As it is stated that he told how the devil played to him in his sleep, many years after, to Lalande, who could make astronomical gossip of any thing, I should not be at all surprised if a certain four-volume work contained evidence of the date of the grave harmonic.

Rameau, not Romieu, is the natural counterpart of Tartini. In 1750 he published his celebrated treatise on harmony, the completion of a system which he had sketched in previous works: and he and Tartini are thus related. Tartini makes his grave note the natural and necessary bass to the consonance which produces it: Rameau makes the harmonics of any given note the natural and necessary treble of the given note as a bass. These contemporary counter-systems are now exploded: they have an uncertain connexion with the truth, no doubt; but the demands and obtains a great number of combinations which neither system will allow.

It is due, however, to Rameau to observe that his discovery,

which appears independent of Tartini's, is that of a physical philosopher, and is developed in a masterly manner. He gave the theory, and detected the beats which occur when the grave harmonic becomes inaudible by lowness. His memoir was published by the Royal Society of Montpellier in 1751, in a collection headed *Assemblée Publique* &c. I have never seen this memoir. There is a long extract from it in a curious and excellent work, which I never see quoted, the *Essai sur la musique ancienne et moderne*, Paris, 1780, 4 vols. 4to, attributed by Brunet to Jean Benjamin de la Borde.

Chladni (*Acoustique*, p. 253) says that the first mention of the grave harmonic which he knew of is by G. A. Sorge (*Anweisung zur Stimmung der Orgelwerke*, Hamburg, 1744), who asks why fifths always give a third sound, the lower octave of the lower note, and concludes that nature will put 1 before 2, 3, that the order may be perfect. If Tartini's evidence in his own favour be disallowed, then Sorge becomes the first observer. But to me the uncontradicted assertion of a teacher whose pupils were scattered through Europe, and included men so well known on the violin as Nardini, Pugnani, Lahoussaye, &c. &c., that he had pointed out the third sound to all his school from 1728 to 1750, is real evidence. Chladni's mention of Tartini is as uncandid as possible:—"Tartini, auquel on a voulu attribuer cette découverte, en fait mention dans son *Trattato* . . . Mentions it! No one knew better than Chladni himself (as he proceeds to show, the moment the paragraph about *priority* is finished) that Tartini's whole book is a system founded upon it. D'Alembert, La Borde, Rousseau, &c. do not dispute Tartini's claim; and the common voice of Europe gives no other name to the discovery.

On this subject in general see the Article *Fondamental* in the *Encyclopædia*, by D'Alembert; Rousseau's *Musical Dictionary*, *Harmonie* and *Système*; Matthew Young's *Enquiry*, &c.

† Smith does not, so far as I can find, attempt to explain these *flutterings*; though I think it may be collected that he knew their cause.

which Smith shows how to make of his own beat; namely, the deduction of the number of vibrations in a note. It is also true that Sauveur applies the term *battemens* to both, and quite correctly; for both are *battemens*, though arising from different sorts of cycles. But it is not true that Sauveur confounds the phenomena by imagining them to be the same, by putting one in the place of the other, or by giving to either the reason of the other. His object is (*Mem. Acad. Sc.* 1701, Paris, 1719, p. 359) to find the *son fixe*, as he calls it, which makes 100 vibrations in a second. He directs us to take organ-pipes, at least two feet long, and to tune diatonic intervals so perfect that not the smallest *battement* shall be perceived. Here he speaks of what I call Smith's beats, of which he clearly knows the negative use, namely, the acquisition of perfect concords by avoiding them. Having thus procured a perfect major and minor third to one note, he sounds them together, the interval being 25 : 24 in ratio of vibrations, and thus procures a *battement* (but this is Tartini's beat) at each 25th vibration of the upper note. By taking nearer* consonances, though certainly not *harmonic* ones, he procures beats which can be easily counted. Dr Smith (*Harmonics*, 2nd Ed. p. 96) complains that he cannot count Sauveur's beats: but, though he used low notes, he took the prominent concords or discords of the scale, which are not near enough.

Dr Young pronounced Smith's work "a large and obscure volume, which for every purpose except the use of an impracticable† instrument leaves the whole subject precisely where it found it." If Dr Young had said that the work was largely obscure, he would have been correct: had the volume been larger, it had probably been less difficult; it is a small volume for the quantity of subject-matter. It leaves the subject where it found the subject only in the minds of those who do not master it; in which number we must place Young (*Peacock, Life of Young*, pp. 128, 129; *Works*, Vol. I. pp. 83, 84, 93, 134—139; *Robison, Mech. Phil.*, Brewster's edition, Vol. IV. pp. 408, 411, 412). One sentence from Young will make it clear that he confounded Tartini's beat with Smith's, though Smith had distinctly stated (p. 97) that "a judicious ear can often hear, at the same time, both the flutterings and the beats of a tempered consonance, sufficiently distinct from each other." But Young says (I. 84), "The greater the difference in the pitch of two sounds the more rapid the beats, till at last, like the distinct puffs of air in the experiments already related, they communicate the idea of a continued sound; and this is the fundamental harmonic described by Tartini."

* He inserts between the two, 24 and 25, the pipe $24\frac{1}{2}$, and making the three sound together, gets a three-pipe beat of 48, 49, 50 vibrations. He then inserts $48\frac{1}{2}$ and $49\frac{1}{2}$, and gets a five-pipe beat of 96, 97, 98, 99, 100 vibrations. These are the beats which he proposes to count; so that, though he sets out with Tartini's beat, his experiment is as far removed as can be, even from the mere use of this, and has nothing to do with Smith's theory. Strange that Young, who actually refers to Sauveur, should call Smith's theory nothing but an extension of this multipipe clatter: strange also that Robison should imply the same thing. It is said that Sauveur's musical ear was very bad. That he sounded these pipes together is clear; for of the *three* first mentioned he says, that the beat of the first and third is faintly audible through the beat of the three. When

his five pipes sounded together, each of the consecutive intervals was something less than the fifth part of a mean semitone. Any one whose ear was thus guillotined might well have exclaimed, *Oh! Musique! que de crimes on commet en ton nom!*

† This entirely relates to the second edition. No doubt some readers of Dr Young have searched their copies of Smith's first edition for this instrument, without finding it. It is the account of an enharmonic harpsichord, which is described in the work, and with improvements in a postscript to the second edition, with a separate title page, in 1762, three years and a half after the publication of the work. The enharmonic piano-forte would not be impracticable, if people cared enough about the accession to pay for it.

Never was anything* more inaccurate: it would make the whole passage from unison to the minor third a preparation for the grave harmonic of that concord. When the unison or other simple concord is gradually mistuned, the "beating becomes more and more rapid, changes to a violent rattling flutter, and then degenerates into a most disagreeable jar." These phenomena are reversed as continued increase of the interval brings us towards another simple concord. The description is due to Robison, who (iv. 414—421) goes through the whole phenomena of the octave. It is clear that Young confounded the two kinds of beat: and even Robison, while animadverting on Young's opinion of Smith, gives strong reason to think that he does not make the distinction. He informs us (iv. 410) that Sauveur had applied *beats*, and that his method is operose and delicate, "even as simplified and improved by Dr Smith." In common with a great number of other writers, he ventures on no explanation of any beats except those which occur in imperfect unisons, in which Tartini's beat is no other than the vibration of the note itself. When he comes to mention the beats of badly-tuned fifths, he declines explanation, and (iv. 409) states what "Dr Smith demonstrates." He calls the method of beats, and to my mind very justly, the greatest discovery (iv. 411) made in the subject since the time of Galileo: but he goes on to depreciate the value of his own opinion by asserting that the theory of Tartini's harmonic is *included* in Smith's theory of the beats of imperfect consonances. The great defect of Smith's theory is its *exclusion* of Tartini's harmonic. Young, in replying, writes as follows (i. 136): "Why then are we obliged to call it Dr Smith's discovery, or indeed any discovery at all? Sauveur had already given directions for tuning an organ-pipe by means of the rapidity of the beating with others, *Mém. de l'Acad.* 1701, 475, ed. Amst. Dr Smith ingeniously enough extended the method; but it appears to me that the extension was perfectly obvious, and wholly undeserving the name either of a discovery or of a theory." This amply proves that neither Robison nor Young had read Smith's theory; and I have very strong doubts that any person who has written on the subject ever did read it. Chladni makes precisely the same mistake as Young. He tells us (*Acous-*

* Except, perhaps, Young's reiteration of his own mistake, several years after, in the *Course of Lectures* (London, 2 vols. 4to, 1807, Vol. i. p. 390). Young here begins by describing the Smith's beat of imperfect unisons, clearly and correctly. He then takes, as his second instance, the Tartini's beat of a well-tuned diatonic semitone, and then repeats the account of the Smith's beats giving the grave harmonic. The terms in which he has spoken of Dr Smith's labours are such as can only be met by convicting him of clear and palpable mistake. Those who may be inclined to wonder that Young should have so signally failed in a matter connected with the distinct conception of a complex undulation, may be reminded that many an investigator has fallen into some singular error in the subject which he had, of all others, made completely his own.

† I think this is a mistake. I find nothing in Sauveur's memoir of 1701 about beats, except what I have described. Lagrange, in his celebrated Turin memoir on sound, refers (p. 75) to Sauveur's memoir of 1700 (not 1701) in so vague a manner that he might be supposed to have Smith's beats in view. On looking at the volume for 1700, I find, not a memoir by Sauveur, but the description of one, forming part of the abstracts called *Histoire*. Here we find that Sauveur did actually commence with imperfect unisons, which give Smith's

beats, that he had a notion of the rationale of such beats, that he had made some experiments, and that a commission of the Academy was appointed to inspect their repetition. The account of this experiment is a part of the history of the subject. "M. Sauveur en rendit conte luy-même et avoüa que pour cette fois elle n'avoit pas bien réussi, car d'autres fois, et en présence des plus habiles Musiciens de Paris, elle avoit paru très juste et très précise. La difficulté de la recommencer, l'appareil qu'il faut pour cela, d'autres occupations plus pressantes de M. Sauveur, et même d'autres recherches d'Acoustique, où il a été obligé de s'engager par la liaison qu'elles avoient avec le Son fixe, ont été cause qu'on en est demeuré là, mais on sçait qu'en fait d'expériences il ne faut pas se décourager aisément, et qu'elles ont pour ainsi dire, leur caprices que l'on surmonte avec le temps" (p. 139). All this means that Sauveur commenced with the beats of imperfect unisons; that he made experiments which satisfied the musicians, but broke down—by *caprice*—before the academicians; that he had in the mean time commenced his acquaintance with Tartini's beats, and was pursuing the researches which led to the paper of 1701, in which Smith's beats are wholly abandoned. It is singular that Smith himself did not see this.

tique, p. 252), that when the vibrations of two sounds come together very rarely, we perceive the coincidences like beats (*comme des battemens, très-desagréables...*) very disagreeable to the ear in a badly-tuned instrument. The more nearly, he goes on to say, the consonance is made perfect, the more insensible the beats become, until at last they are lost in the sensation of a feeble resonance with a grave sound. And he ends by telling us that an instrument is not in tune if any one of its intervals allow beats to be heard. According to Chladni, then, *unisons* ought to give a grave sound when perfectly tuned; to say nothing of his appearing to believe in some system of tuning *a whole instrument* in which there are no beats.

All the modern writers with whom I am acquainted content themselves, at the utmost, with describing the phenomenon, and giving some account of the beats of imperfect unisons, except as I proceed to mention. Some time ago, after detecting the explanation from the formulæ, and then unravelling the demonstration of the same formulæ with very great difficulty, I searched far and wide to see if any writer had appreciated and acknowledged the skill with which Dr Smith had concealed his truth at the bottom of a well of learning. The only writers in whom I found a solution of the problem were as follows. William Emerson, a sound and once well-known, but now nearly obsolete, writer, gave a true solution (p. 484) of the problem in his *Algebra*, published in 1763. His method is very obscure just at the *pinch* of the demonstration: we see that certain recurrences are established, but are left wholly in the dark as to why *those* recurrences should explain the beats; it is quite as likely that two of them should go to a beat as one. Mr Woolhouse, in his *Essay on Musical Intervals* (London, 1835, 8vo. p. 84), the best modern manual of mathematical harmonics which I know of, has treated the problem in the same manner, arriving at another variety* of the formula. Both these methods want the introduction of Tartini's beat in its connexion with Smith's; and this the following treatment of the subject will supply.

Let m and n be two numbers prime to one another, $m > n$, and let the higher note make m vibrations while the lower note makes n . In the diagram I shall suppose $m = 5$, $n = 3$, or the interval a major sixth. I shall also suppose each whole wave to be one of condensation, for simplicity. And first, let two zeros of condensation, one in each wave, be synchronous. The following diagram represents the whole of one wave of Tartini's beat, whether it be the

* Emerson arrives at the formula which I presently mark as $(1-x)Mn \div x$; Mr Woolhouse arrives at $(1-x)Nm$. Looking at all probabilities, as derived from Emerson's life, habits, and access to books, I very much doubt his method being derived from Dr Smith. He was a musician, and an amateur tuner of instruments; and he was mechanic enough to enrich his own *virginal* with additional semitones. He was nearly fifty before the first edition of Smith appeared, he lived in the county of Durham on a very small fixed income (about £60 a-year), his writings show very little reading, and the library which he sold before his death, the collection of nearly forty years, was valued by himself under £50. If I could only establish a high probability of acquaintance between Emerson and Thomas Wright, now known as the speculator on the milky way, who lived within twelve miles of Emerson, I should consider the united chances of Wright having possessed the book

and having lent it to Emerson as giving a higher probability to Emerson having seen it than anything I can create from comparison of the two methods. It is very likely, then, that he had not seen Smith's *Harmonics*. The amusing biography of Emerson, which is prefixed to his collected works, and which appears to have been written by some one who had ample information, states that he was a very desultory student till after thirty years of age. Having been treated with contempt by his wife's uncle, he determined to gain a name, that he might prove himself the better man of the two. This he has done: if the name of his relative were now worth inserting, it would only be in connexion with the statement, true or false, that, though possessed of two livings and a stall, he made a large income by the practice of surgery. Emerson died in 1782, in his 81st year.

pulse of a grave harmonic, or only one of Smith's *flutters*: namely, five waves of the upper note, three of the lower, and the resultant wave.



The abscissa represents 15 equal portions of time, of which the component waves take successive threes and fives; the ordinates represent the condensations at the end of the times represented by the abscissas. The thick line, whose ordinate is always the sum of the other two, represents the wave of Tartini's beat, which is repeated in the next fifteen portions of time.

The united effect of the two waves is one particular *phase* of a major sixth: a pulse of the grave harmonic in which gradations of loudness and faintness are distributed in a certain manner through 15 portions of time, to be strictly repeated in the next 15 portions, and so on. An unlimited number of other phases exist, one for every mode in which the zero of condensation of the shorter wave can be laid down in the longer wave, so as to produce a law of loudness and faintness which is not found in any other mode. Thus the following is the diagram in which the maximum condensation of the shorter wave synchronises with the zero of condensation of the longer wave.

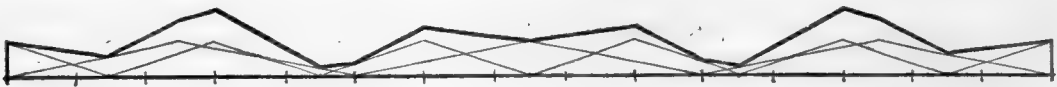

We have now Tartini's beat under a different type, in which the loudness and faintness are distributed in another way: the consonance of a major sixth, as before, with a different kind of pulse for the grave harmonic, if there be one. Whether the ear would acknowledge any difference between two major sixths of these different types, cannot be settled; for it is not in our power to *start* the pulses as we please. But the ear *does* acknowledge the gradual progression through all the types, by recognizing what I have called *Smith's beat*. If the consonance be a very little mistuned, Tartini's cycle is not sensibly altered in character, but its recommencement undergoes a very small change. If the higher note be tuned a little too sharp, for example, so that the shorter wave is a very little less than three-fifths of the longer wave, Tartini's cycle, or something excessively like it, begins a little sooner the second time than it should do; and the zero of condensation of the shorter wave is thrown back a little. This effect is doubled at the next commencement, trebled at the next one, and so on: accordingly, in a consonance slightly mistuned, the approximate compound pulse goes through all the phases which variations in the mode of setting off can give to the true one. This is the most marked geometrical effect upon the pulses; and Smith's beat is the most marked acoustical effect upon the ear. The connexion of the two is then of the highest probability: and this becomes certainty so soon as, and not until, the study of the beats, and their application to

questions of temperament, shows that the theory agrees with other theories, and with practice. Smith's beat* is a kind of *disturbed* orbit, of which Tartini's beat is the *instantaneous* orbit.

The phenomenon itself is different to different ears. To some it consists in alternations of louder and softer: and undoubtedly there are changes from condensation reinforcing condensation, and rarefaction rarefaction, to condensation balanced by rarefaction, and rarefaction by condensation. To others it consists in alternate perception of the two sounds of the consonance; and this also is intelligible, as the stronger parts of the two waves alternate. For myself, though I can perceive both the effects above mentioned when I look out for them, the phenomenon which forces itself on my ear is an alternation of vowel-sounds†, as in *u-a u-a u-a*, &c. pronounced in the Italian way.

The *time* of a beat depends upon a circumstance which I suppose, by the manner in which many writers have confined themselves to the case of imperfect *unisons*, has not been clearly apprehended. The diagrams are only detached portions of a succession unlimited in both directions. If the times of vibration be $3a$ and $5a$, (so that a represents the greatest common measure of the times of vibration, which is repeated 15 times in Tartini's beat,) and if one of the shorter waves begin at zero with one of the longer ones, the first, third, and fifth of the shorter waves are advanced 0 , a , $2a$, upon the several longer waves. If the first of the shorter waves be advanced x ($< a$) upon the longer one with which it began, then the advances just spoken of become x , $a + x$, $2a + x$. Accordingly, looking at the full successions, while x progresses from 0 to a the consonance passes through all its phases. Every possible variety of Tartini's cycle is exhibited during the motion of the beginning of one wave, not through *the whole* of the other, but through *that portion of the other which is performed in the time which is the greatest common measure of the times of the two waves*. In disentangling Dr Smith's explanation, I thought it looked much as if he had first counted on *the whole* of the other wave, had found that his results would not agree with experiment, had detected the true submultiple of the other wave by comparison of his theory with experiment, and had then corrected his former theory. This may be fancy: but, should any one ever read Dr Smith's book again, I should recommend his attention to this point. And should he find

* I have looked in many places to see if I could discover the two beats in any other connexion than that of confusion between the two. I once thought I had succeeded; for there is a paper by Lord Stanhope (Tilloch's *Phil. Mag.* Vol. xxviii. 1807, June—September, p. 150) which is sometimes cited in a manner which would make one suppose he had the distinction. But on looking at this paper, I find that his distinction between a *beat* and a *beating* is this, that the first is merely the vibration of the note, the second is Smith's beat. There is a rather obscure paragraph at the end, in which he speaks of the *beating of a beating* occasioned by two badly turned fifths DA, DA, in different octaves, sounding together.

† And so it struck Emerson, who says (*l. c.*)—"Its noise is such as this, *waw, aw, aw, aw*, or *yâ, yâ, yâ, yâ, yâ*. Our business is to find out in how many vibrations this perturbation happens, or how many *yaws* in a second of time." In the organ-pipe, in which the effect is much *coarser* than in the string, the alternation of vowels is not very self-asserting. Since the text was written, I have tried the comparison of pipes

again, which I had never heard, with any reference to beats, for many years. Mr Davison (of the firm of Gray and Davison) instructed one of his tuners to prepare an octave of equal temperament, by ear in the usual way. On trying one of the fifths, the first thing which struck me was that the beating seemed to be about double what it ought to be. Without saying anything, I asked the tuner to count the beats in a minute in his own way; his counting gave the half of mine, and agreed with the theory, nearly. So little did the alternation of vowels present itself, that is, so like was each half beat to the other, that I did not even remember the phenomenon. It was only on a subsequent day, after more practice, that I caught the two vowels. The equal temperament, tuned by a practised tuner, brings the beats near enough to the theory to prove that the complete cycle of Tartini's beat, and not any multiple or sub-multiple of it, is the cause of the phenomenon called Smith's beat, namely, the sound of pulsation which is heard in two halves, with different vowels in the two.

the reading very easy, I would desire him to put himself, if possible, into the position of a reader who had had no one but Dr Smith to help him. For of all the difficulties I have ever encountered with any success, I have no hesitation in calling the theory of beats, as presented by its author, the very greatest. I would compromise such another job, if such another there be, by choosing rather to explain to a pupil of reasonable preparation, any fifty pages of the *Principia*, and of the *Théorie des Probabilités*, and of the *Disquisitiones Arithmeticae*.

I now proceed to the formulæ which the subject requires. Let the higher note (perfect) make m while the lower note makes n vibrations; $m : n$ being > 1 and in its lowest terms. Let k be what we may call the *adjusting factor*, that is, let nk and mk be the actual numbers of vibrations in one second of the lower and higher notes. Let ma and na be the actual times of vibration, in seconds, of the lower and higher notes. Then $mnka = 1$. Let $na + \theta$ be the time of vibration of the upper note in the imperfect consonance which gives the beats. When θ is positive, the consonance is tuned flat, the commencements of the more rapid vibrations advance upon those of the less rapid, and the beats may be said to move *forwards*. The contrary when θ is negative. It is the same thing to the ear whether the beats move forwards or backwards. Let x be the ratio of the consonance of the perfect and imperfect upper note; that is, let $x = na : na + \theta$. Thus $x < 1$ when the upper note is too flat. And let N and M be the actual numbers of vibrations per second in the lower and higher notes of the imperfect consonance. Hence

$$\frac{m}{n} x = \frac{M}{N}, \quad Nma = 1, \quad M(na + \theta) = 1, \quad x = \frac{na}{na + \theta}$$

$$\theta = \frac{1-x}{x} na, \quad kmna = 1, \quad kn = N.$$

Let β be the number of beats in one second. A beat, as shown, lasts through as many of the shorter vibrations as there are units in $\frac{a}{\theta}$: its time is then $\frac{(na + \theta)a}{\theta}$; so that we have

$$\beta = \frac{\theta}{(na + \theta)a} = \frac{1-x}{a} = (1-x)kmn = (1-x)mN = \frac{1-x}{x} nM = mN - nM.$$

Dr Smith does not elicit* any of these formulæ, the last of which is remarkably simple. Thus if a fifth be tuned imperfectly to 200 and $301\frac{1}{2}$ vibrations per second, we have

$$200 \times 3 - 301\frac{1}{2} \times 2 = -3,$$

or the consonance is tuned sharp to 3 beats per second. The number of beats per second depends only on the number of vibrations by which the upper note is wrongly tuned, and the smaller of the two lowest terms of the perfect consonance. Let M' be the proper number of vibrations for the upper note, so that $M' : N = m : n$, then $\beta = (M' - M)n$. Or

* Since this paper was written the article 'Beats' in the *Edinburgh Encyclopædia*, attributed to Mr John Farey, has been pointed out to me. This article contains Smith's formula, with two varieties arising out of different modes of expressing the division of the octave, Emerson's method, and the formula $mN - nM$. But no explanation is given.

thus:—In every consonance of which the lower number is n , every wrong vibration per second in the upper note is n beats per second*. With this theorem as a key, a rationale can be obtained without difficulty; but it does not connect the two beats, and would, I think, be subject to the doubt I have cast on Emerson's method.

The formulæ given by Dr Smith are obtained as follows. The *comma*, or difference of a major and minor tone, being $81 : 80$, let θ correspond to the fraction $q : p$ of a comma. Then

$$x = \left(\frac{80}{81}\right)^{\frac{q}{p}}.$$

Now $(1 - \alpha)^n = 1 - \frac{2n\alpha}{2 + (n - 1)\alpha}$ nearly; α being small:

whence $x = \left(\frac{80}{81}\right)^{\frac{q}{p}} = 1 - \frac{2q}{161p + q}$ nearly.

$$\text{And } \beta = (1 - x) mN = \frac{2q}{161p + q} mN \left. \vphantom{\beta} \right\} \\ = \frac{1 - x}{x} nM = \frac{2q}{161p - q} nM \left. \vphantom{\beta} \right\}$$

which are Smith's formulæ (2nd ed. p. 82).

When the upper note is too sharp, q must be made negative, the negative sign of β being neglected.

If μ be the fraction of a mean semitone by which the upper note is flat, we have, for the number of beats in a *minute*,

$$60 \left(1 - 2^{-\frac{\mu}{12}}\right) mN, \text{ or } \frac{104}{30} \mu mN, \text{ or } 104\mu \left(\frac{1}{30} - \frac{\mu}{1000}\right) mN$$

nearly, and more nearly. If the octave be composed of 30103 atoms, of which the upper note is tuned flat by a atoms, the number of beats in a *minute* will be

$$\cdot 001381551a (1 - \cdot 0000115129a) mN \text{ very nearly,}$$

$$\text{or } \frac{4 \times 8 \times 13}{301000} amN \text{ nearly.}$$

These formulæ are not accurate enough to give the beats in a minute within three or four, unless both terms be used: and, the vibrations being given, $mN - nM$ is much more easy.

* The passage over the greatest common measure being fairly arrived at, as the time of a beat, the transition to the formula $mN - nM$ may be very briefly made. We know that, m and n being prime to one another, there is, before we arrive at mn , one way and one only in which $pm - qn = 1$; and one way and one only in which $qn - pm = 1$. The ratio $N : M$ of the numbers of vibrations in the erroneous consonance, and also of the lengths of the waves, is not $n : m$, but

$$m \frac{N}{M} : m, \text{ or } n + \frac{mN - nM}{M} : m,$$

consequently the commencement of the shorter wave gains the fraction $\frac{mN - nM}{M}$ of a common measure in every vibration of the higher note, than is $mN - nM$ common measures in one second, or in M higher vibrations; and each gain of a common measure is a beat. This demonstration, a little more developed, will be, I should think, the best that can be given.

Let the notes of the imperfect consonance be P , Q , and let P^1 be the octave above P . If the interval PQ be tuned too flat, then QP^1 is two sharp, and *vice versa*. All remaining as above for PQ , in passing from PQ to QP^1 we must change N , M into M , $2N$. If m be an odd number, we must change n , m , into m , $2n$; but if m be even, n , m , must change into $\frac{1}{2}m$, n ; since the fundamental ratio must be in its lowest terms. And we must also change the sign of q , neglecting the negative sign of the value of β , when it occurs. Consequently, β^1 being the number of beats of QP^1 in a second, we have

$$(m \text{ odd}) \beta = \frac{2q}{161p + q} Nm, \quad \beta^1 = \frac{2q}{161p - q} M \cdot 2n = 2\beta;$$

$$(m \text{ even}) \beta = \frac{2q}{161p + q} Nm, \quad \beta^1 = \frac{2q}{161p - q} M \cdot n = \beta.$$

That is, when the fundamental number (in the ratio $m : n$) of the mistuned note is *odd*, the interval complementary to the octave beats twice as fast as the lower interval first given. But when this fundamental number is *even*, the interval and its octave complement have the same rate of beating. This is one of Smith's* experimental verifications, and is a very easy one. He is of opinion that an octave might probably be tuned with more perfection by the isochronous beats of a minor and major concord composing it, than by the judgment of the most critical ear.

What precedes is a particular case of the following theorem:—Let N , M , L , be three ascending notes represented by their numbers of vibrations per second. Let N make n vibrations while M makes m : let M make m' vibrations while L makes l : the fractions $m : n$ and $l : m'$ being in their lowest terms. Let the imperfect consonances NM , ML , NL , beat severally β , β' , B , times per second: β being positive when the higher note is flat, and negative when it is

* There must needs be some way of explaining the excessive difficulty of this one work of Dr Smith's. His *Optics*, if not a model of perspicuity, is by no means notable for obscurity; on the contrary, I find it abounding in sufficiently good descriptions of machinery, a point in which an obscure writer is generally most perplexed and perplexing. I take the cause of Dr Smith's failure of clearness in the *Harmonics* to be that he was a practical musician, well versed in the practical writers. I suppose others have agreed with myself in noting that the worst explainers are those who have to describe the purely conventional, without having had it distinguished from the natural or the essential in their education. First come the writers on games of chance, who all, or with the rarest exception, proceed to explain whist or hazard by commencing at the point at which they imagine *a priori* knowledge of the arrangements ceases. Next come the musicians, with whom a five-line stave, &c. are in the nature of things. Now Dr Smith had got into the way of interchanging the practical and theoretical, the accidental and the essential, &c. The manner in which he treats the theorem on which this note is written is perhaps the easiest instance to produce. He gets into the theorem in a way which leads him to the table of ratios of vibrations, and he arrives at this result, that when the *minor* consonance is above the *major*, the higher consonance beats twice as quick as

the lower, but when the minor consonance is below the major, the beats are the same. And not until he has pointed this out, does he proceed to note that the greater term of the ratio of a minor consonance is even, &c. And his final theorem is stated in terms of major and minor consonance, it being merely accidental, so far as our knowledge is concerned, that the numerators of minor consonances happen to be even, in the cases in which they are useful. The usual minor intervals are the tone $(\frac{10}{9})$; the third $(\frac{6}{5})$; the sixth $(\frac{8}{5})$; the seventh $(\frac{16}{9})$. The usual major intervals are the tone $(\frac{9}{8})$; the third $(\frac{5}{4})$; the fourth $(\frac{4}{3})$, in which there is a failure; the fifth $(\frac{3}{2})$; the sixth $(\frac{5}{3})$; the seventh $(\frac{15}{8})$. In the minor and major semitone $(\frac{25}{24}, \frac{16}{15})$ the rule is inverted; and also in the minor fifth $(\frac{45}{32})$. Keeping, however, to common intervals used in tuning, and calling the *fourth* a minor to the *fifth*, it is a pretty practical rule that the duplication of beats takes place when the minor interval is above the major.

sharp; and the same of the rest. Let g be the greatest common measure of ml and $m'n$. Then

$$l\beta + n\beta' = gB.$$

From this we may obtain such theorems as the following. The beats of a minor third exceed those of the following major third by twice the beats of the whole fifth which they make up. Twice the beats of a minor third exceed three times the beats of the major third which it follows by five times the beats of the fifth they make up.

Smith's beats themselves have a long inequality whenever $\frac{a}{\theta}$ is not an integer; of which I suppose (though I am by no means sure) the ear could hardly be made sensible. The theory of the beats of a consonance of more than two notes would offer no difficulty, if there be any thing presented to the ear which it would be of any interest to explain.

A. DE MORGAN.

UNIVERSITY COLLEGE, LONDON,
August 12, 1857.

POSTSCRIPT.

A FEW observations on tuning and on temperament will not be out of place. The method of tuning employed in this country at present is simply *adjustive*. In equal temperament, for example, the tuner gets one octave into tune, with its adjacent parts so far as successions of fifths up and octaves down require him to go out of it; and the notes thus tuned are called the *bearings*: all the rest is then tuned by octaves from the bearings. The method of tuning the bearings, after taking a standard note from the tuning-fork, consists merely in tuning the successive fifths a little flat, by the estimation of the ear, making corrections from time to time, as complete chords come into the part which is supposed to be in tune, by the judgment of the ear upon those chords. Proceeding thus, if the twelfth fifth appear to the ear about as flat as the rest, the bearings are finished: if not, the tuner must try back. The system generally used is the equal temperament: when any other is adopted, beats are sometimes, but not always, employed, that is, *counting the beats*. For the ordinary tuner, even in equal temperament, learns to help himself by a perception of the rapidity of the beating: but without numerical trial.

Now it appears to me that there is in this a loss of time and a loss of accuracy. Different tuners, however excellent their ears, do not agree in their results. Two men, tuning different

compartments of the same organ, produce two systems which do not agree: they take care that their tuning-forks shall give them the same standard-note; but this is all they can get. Many years ago I had two *dulcimers*, as I suppose they must be called, of a couple of octaves each: the notes were given by single strings, and the sound was produced by a hammer held in the hand; they stood exceedingly well in tune, and the sound was as pure as that of a tuning-fork. When I tuned one to equal temperament, as I thought, and then the other, I never found agreement, though each was satisfactory by itself. I soon left off, setting down the discordance to my own inexperience. But an old professional tuner, to whom I mentioned the subject, assured me that he did not believe either that any tuner gained *equal* temperament, or that any one tuner agreed with himself or with any other. He summed up by saying that "equal temperament was equal nonsense."

An octave of tuning-forks might easily be prepared, adjusted with exactness to any temperament by beats. These beats can be heard in a consonance of tuning-forks as well as in one of strings or of pipes. The preparation of a standard set, for the manufacturer's own use, would cost time and trouble: but the standards once at hand, copies might be taken off by unisons with comparative ease. The labour of obtaining the *bearings* from the tuning-forks would be small compared with that of adjustment, as now practised. In tuning the organ, I feel certain that the ear of the tuner must be much injured, for the moment, by the hideous squalling slides which the pipe sounds while the tuning-instrument is inserted and turned about at the top. He might still be a judge of a perfect unison; but I should no more imagine him able to know the fiftieth part of a mean semitone from the twenty-fifth, when his ear is just out of this abominable clamour, than I should rely on the tenth part of a second from the wire of an astronomer who had the instant before been tossed in a blanket. The sensibility to false intonation languishes and almost dies during a powerful crash of the whole orchestra; but it is fostered and nourished by soft passages performed on a few instruments.

When beats are employed at the instrument itself, a watch is in several respects a difficult standard. The counting should begin when the ear is well *in gear* with the beats, which will not happen just at the five seconds or the quarter minute. And the employment of the eye at the very commencement of counting is confusing to the ear. A regulated metronome might be used, but I suspect it would be a troublesome instrument. A half-minute sand-glass (emery powder should be used) would probably be found the best time-piece: this could be turned over when the ear is in repose on the beats; and the counting would begin from the tuner's own perception of his own act, with that composure which would arise from the act being in his own power.

The system of equal temperament is to my ear the worst I know of. I believe that the tuners obtain something like it. A newly-tuned pianoforte is to me insipid and uninteresting, compared with the same instrument when some way in its progress towards being out of tune. Now as every bearable change must be called *temperament*, and not *maltonation*, I suppose that, in passing from key to key by modulation, the variety which the temperament of wear and accident produces is more pleasing than the dead flat of equal temperament. I give the results of four systems, which I shall now describe.

P is equal temperament, on which I need say no more.

Q is a system in which the change of temperament of the fifth, in passing from a key to that of its dominant, is always of the same amount, one way or the other. That is, the temperaments of the fifths in the keys of C, G, D, A, E, B, F \sharp , are $m, 2m, 3m, 4m, 5m, 6m, 7m$; while those in the keys of C \sharp , G \sharp , D \sharp , A \sharp , F are $6m, 5m, 4m, 3m, 2m$. Here $4m$ must be the temperament of the fifth in the equal system. I have described this system in the article *Tuning in the Penny Cyclopædia*.

R is a system in which all the *major* thirds are equally tempered: and the variety of the fifths in passing from key to key is made as great as, consistently with this condition, it can be.

S is a system in which all the *minor* thirds are equally tempered, the varieties of the fifths being made as great as they can then be.

In the article cited above, I have exhibited all the relations of the temperaments in the form of three theorems, including 25 equations, as follows. The temperament of fifths and minor thirds is considered positive when they are tuned flat: that of major thirds is positive when they are tuned sharp.

1. The sum of the temperaments of the fifths in all the 12 keys must be $\cdot 2346$ of a mean semitone.

2. The keys being arranged dominantly, that is, in the order C, G, D, A, E, B, F \sharp , C \sharp , G \sharp , D \sharp , A \sharp , F, C, G, D, ... the temperament of the *major* third in any key together with the temperament of the fifth *in that key* and the three *succeeding* keys will always amount to a comma, or $\cdot 2151$ of a mean semitone.

3. The temperament of the *minor* third in any key, together with the temperaments of the fifths in the *three preceding* keys, will always amount to a comma.

Thus in all systems, the temperament of AC \sharp , together with those of AE, EB, BF \sharp , F \sharp C \sharp , will make a comma. And the temperaments of AC, together with those of CG, GD, DA, will make a comma.

If then the temperaments of the fifths go in cycles of four, that is, if the twelve keys, dominantly arranged, have the temperaments $p, q, r, s, p, q, r, s, p, q, r, s$, in their fifths, the temperament of every major third will be $p+q+r+s$ less than a comma, or $\cdot 0782$ of a mean semitone less than a comma. In the system *R*, I have taken $p=0, q=\cdot 0391, r=0, s=\cdot 0391$: that is, the dominantly consecutive fifths are alternately perfect and tempered as much again as in equal temperament. This is the way of satisfying the condition $3(p+q+r+s) = \cdot 2346$, which gives most variety of key. The temperaments of the minor thirds in dominantly consecutive keys are alternately $\cdot 1369$ and $\cdot 1369 + \cdot 0391$, equal temperament giving $\cdot 1564$ to all.

If the temperaments of the fifths run in cycles of three, as in $p, q, r, p, q, r, p, q, r, p, q, r$, it follows that the temperament of every minor third is $p+q+r$ less than a comma. And $p+q+r$ must be $\cdot 0587$. In system *S* I have made $p=0, q=\cdot 01955$ as in equal temperament, $r=2q$; which satisfies $4(p+q+r) = \cdot 2346$. The temperaments of the major thirds in dominantly successive keys are $\cdot 1564, \cdot 1564 - q, \cdot 1564 - 2q$: that is, the major third is never more tempered than the minor third in equal temperament.

The tables here seen are described in the following paragraphs:—

Intervals in Mean Semitones.

	P	Q	R	S	
C	0	0·00000	0·00000	0·00000	C
C#	1	1·00000	1·01955	1·01955	C#
D	2	2·02444	2·00000	2·01955	D
D#	3	2·98534	3·01955	3·00000	D#
E	4	4·02932	4·00000	4·01955	E
F	5	4·99022	5·01955	5·01955	F
F#	6	6·01466	6·00000	6·00000	F#
G	7	7·01466	7·01955	7·01955	G
G#	8	7·99022	8·00000	8·01955	G#
A	9	9·02932	9·01955	9·00000	A
A#	10	9·98534	10·00000	10·01955	A#
B	11	11·02444	11·01955	11·01955	B

Vibrations in one Minute.

Beats in one Minute.

	P	Q	R	S	P	Q	R	S	
C	14400·0	14400·0	14400·0	14400·0	48·8	12·2	00·0	00·0	C
C#	15256·3	15256·3	15273·5	15273·5	51·7	77·5	103·4	51·7	C#
D	16163·5	16186·3	16163·5	16181·7	54·7	41·1	00·0	109·5	D
D#	17124·6	17110·1	17143·9	17124·6	58·0	58·0	116·0	00·0	D#
E	18142·9	18173·6	18142·9	18163·4	61·4	76·9	00·0	61·5	E
F	19221·7	19210·8	19243·4	19243·4	65·1	32·5	130·2	130·2	F
F#	20364·7	20381·9	20364·7	20364·7	69·0	120·7	00·0	00·0	F#
G	21575·6	21593·9	21600·0	21600·0	73·0	36·5	146·2	73·2	G
G#	22858·6	22845·7	22858·6	22884·4	77·4	96·6	00·0	154·9	G#
A	24217·8	24258·9	24245·2	24217·8	82·0	82·1	164·1	00·0	A
A#	25657·9	25636·2	25657·9	25686·9	86·8	65·1	00·0	87·0	A#
B	27183·6	27222·0	27214·3	27214·3	92·0	138·2	184·2	184·2	B

The vibrations are calculated from the formula

$$\log M = \log N + \frac{1}{12} \log 2 \times x,$$

where M and N are the vibrations in the higher and lower notes, and x the number of mean semitones in the interval. The beats are calculated from the formula $mN - nM$; for the fifths $3N - 2M$. The beats are those of each note with the fifth above it: thus A# F¹ (the octave above F) beats 86·8 times in a minute in equal temperament (P).

The vibrations are taken as in the pitch frequently used for organs, when not wanted to combine with the orchestra, that is, a diatonic semitone (15 : 16) below the ordinary concert-pitch of our day, in which C (on the first line below the treble) gives 256 double vibrations per second. In tuning to the concert-pitch, each number in the lower table, be it of vibrations or of beats, must be increased by its 15th part. For an octave above, the number of beats must be doubled: for an octave below, it must be halved. Thus, CG beating 48·8 times in a minute, C₁G₁ beats 24·4 times, and C¹G¹ beats 97·6 times in a minute.

I feel sure that the results of this principle of *variety in the keys* would, if fairly tried, be found more satisfactory than those of equal temperament. Nor do I at all apprehend that the principle is carried too far: on the contrary, I should predict that the system *R*, in which the difference between dominantly successive keys is greater than in the others, would be the best of all. But by making *p, q, r, s*, in *R*, and *p, q, r*, in *S*, more nearly equal than in the instance given, any less amount of adherence to the distinctive feature might be secured.

It is useless to speculate on systems with any view of materially diminishing the number of beats in the thirds and sixths. In equal temperament, the consonance $G A \sharp$ beats more than 1150 times in a minute, while $G D^1$ (D^1 the octave above D) beats only 73 times. Nor can the beats be reduced, in the different consonances of a chord, either to equality, or to near commensurability, throughout any considerable portion of the scale. It is the irregularity of the beating which is its chief disadvantage: regularity would give merely the effect of a faint drum-accompaniment; but such change as that from $C F C^1$, in which $C F$ and $F C^1$ beat equally, to $C G C^1$, in which $G C^1$ beats twice as fast as $C G$, is the real annoyance. A further disadvantage is that the multitudinous beats are thrown on the consonances which are least suited to take them. The fourths and fifths should be called *martial* consonances, the thirds and sixths *pastoral*: but the bray of the beats is thrown on the thirds and sixths, and is never so distressing in the fourths and fifths.

The subject will never be fairly entered upon, as to true comparison of systems of temperament, until the bearings are tuned from a system of forks, one to each semitone. I think it probable that nothing but the general ignorance of the theory of beats, arising out of the obscurity under which the subject has been presented, has hitherto prevented the construction of such standard bearings.

A. De M.

January 18, 1858.

VIII. *On the Genuineness of the Sophista of Plato, and on some of its philosophical bearings.* By W. H. THOMPSON, M.A., *Fellow of Trinity College, and Regius Professor of Greek.*

[Read Nov. 23, 1857.]

IN selecting the *Sophista* of Plato for the subject of this paper, I have been influenced by certain passages in an interesting contribution to our knowledge of some parts of the Platonic system which was read by the Master of Trinity at a former Meeting¹. I have principally in view to assert what was then called in question, the genuineness of this dialogue, and the consequent genuineness of the *Politicus*, which must stand or fall with it; but I am not without the hope of throwing some new light upon the scope and purpose of the *Sophista* in particular, and upon the philosophical position of Platonism in reference to two or three now forgotten, but in their day important schools of speculation. Such an inquiry cannot fail, I think, to be interesting to those members of the Society whose range of studies has embraced the fragmentary remains of the early thinkers of Greece, as well as the more polished and mature compositions of Plato and Aristotle: for such persons must be well aware that it is as impossible to account for the peculiarities of these later systems without a clear view of their relation to those which went before them, as it would be to explain the characteristics of Gothic architecture in its highest development without a previous study of those ruder Byzantine forms out of which it sprang; or to account for the peculiar form of an Attic tragedy without a recognition of the lyrical and epic elements of which it is the combination. Nor is this all. The writings both of Plato and Aristotle abound with critical notices of contemporary systems, with the authors of which they were engaged in life-long controversy: and whoever refuses to take this into account will miss the point and purpose not only of particular passages, but, in the case of Plato, of entire dialogues. In the search for these allusions to the writings or sayings of contemporaries, we have need rather of the microscope of the critic than of the sky-sweeping tube of the philosopher: and a task so minute and laborious is not to be required of any man whose literary life has loftier aims than the mere elucidation of the masterpieces of classical antiquity.

I say then at the outset of this inquiry, that I not only hold the *Sophista* to be a genuine work of Plato, but that it seems to me to contain his deliberate judgment of the logical doctrines of three important schools, one of which preceded him by nearly a century, while the remaining two flourished in Greece side by side with his own, and lasted for some time after his decease. I hold the *Sophista* to be, in its main scope and drift, a critique more or less

¹ *Cambridge Philosophical Transactions*, Vol. IX. Part IV.

friendly, but always a rigorous and searching critique of the doctrines of these schools, the relation of which to each other is traced with as firm a hand, as that of each one to the scheme which Plato proposes as their substitute. These positions I shall endeavour to substantiate hereafter, but I shall first produce positive external evidence of the authenticity of the dialogue under review.

1. The most unexceptionable witness to the genuineness of a Platonic dialogue is, I presume, his pupil and not over-friendly critic Aristotle. Allusions to the writings of Plato abound in the works of this philosopher, of which the industry of commentators has revealed many, and has probably some left to reveal. These allusions are frequently open and acknowledged; the author is often, the dialogue occasionally named¹: but in the greater number of instances no mention occurs either of author or dialogue, and the *φασί τινες* of the philosopher has to be interpreted by the sagacity of his readers or commentators. I shall begin with an instance of the last kind, where however the identity of phraseology enables us to identify the quotation. In the treatise *De Anima*, III. 3. 9, we read thus: *φανερὸν ὅτι οὐδὲ δόξα μετ' αἰσθήσεως οὐδὲ δι' αἰσθήσεως, οὐδὲ συμπλοκὴ δόξης καὶ αἰσθήσεως φαντασία ἂν εἴη.* A "combination of judgment and sensation" is evidently the same thing as "judgment with sensation;" why then this tautology? It is explained by a reference to Plato's *Sophista*, § 107, p. 264 B, where we are told that the mental state denoted in a previous sentence by the verb *φαίνεται*, is "a mixture of sensation and judgment," *σύμμιξις αἰσθήσεως καὶ δόξης*; and just before, that when a judgment is formed, one of the terms of which is an object present at the time to the senses, we may properly denote such judgment as a *φαντασία*. "Ὅταν μὴ καθ' αὐτὴν ἀλλὰ δι' αἰσθήσεως παρῆ τιμὴ τὸ τοιοῦτον αὐτῷ πάθος, ἂρ' οἶόν τε ὀρθῶς εἰπεῖν ἕτερόν τι πλὴν φαντασίαν." A *φαντασία* is, it will be seen, according to Plato a variety of *δόξα*. The distinction was perhaps not worth making, but it is perfectly intelligible; and in restricting a popular term to a scientific sense, Plato is taking no unusual liberty. Aristotle, however, needs the word for another purpose, and accordingly pushes Plato's distinction out of the way.

The only word used by Aristotle which Plato does not use is *συμπλοκή*: he wrote *σύμμιξις*, but it is remarkable that the word *συμπλοκή* does occur two or three times over in this part of the dialogue; hence Aristotle, writing from memory, substitutes it for the *σύμμιξις* of the original. One of the most learned and trustworthy of his commentators, Simplicius, has the gloss: *τοῦ Πλάτωνος ἐν τῷ Σοφίστῃ καὶ ἐν τῷ Φιλήβῳ τὴν φαντασίαν ἐν μίξει δόξης τε καὶ αἰσθήσεως τιθεμένου, ἐνίστασθαι πρὸς τὴν θέσιν διὰ τούτων δοκεῖ.* Now in the *Philebus* the definition in question does not occur, though the mental act which Plato calls *φαντασία* is graphically described, and the cognate participle *φανταζόμενον* is used in the description (p. 38 c). The passages quoted from the *Sophista* are therefore here alluded to, for there are none such in any other dialogue, and the restricted use of the term is peculiar to the author of the *Sophista*.

¹ Sometimes without Plato's name, as ἐν τῷ Ἰππία, ἐν τῷ Φαίδωνι. It is remarkable that these are the only two dialogues quoted by name in the *Metaphysics*: though Plato's

entire system comes under review in that work, of which one book is appropriated to the theory of ideas alone. The *Parmenides*, which is largely drawn from, is not once named.

2. The next passage I shall quote refers not to the *Sophista*, but to the *Politicus*, which is a continuation of it. It is familiar to readers of the *Politics*, in the first chapter of which Aristotle writes thus: Ὅσοι μὲν οὖν οἴονται πολιτικὸν καὶ βασιλικὸν καὶ οἰκονομικὸν καὶ δεσποτικὸν εἶναι τὸν αὐτὸν οὐ καλῶς λέγουσιν· πλήθει γὰρ καὶ ὀλιγότῃ νομίζουσι διαφέρειν ἀλλ' οὐκ εἶδει τούτων ἕκαστον...ὡς οὐδὲν διαφέρουσαν μεγάλην οἰκίαν ἢ μικρὰν πόλιν. "Those persons are mistaken who pretend that the words statesman, king, housemaster and lord mean all the same thing, differing not specifically, but only in respect of the number of persons under their controul; for, say they, a large household is but a small state." With this compare Plato's *Politicus*, 258 E: πότερ' οὖν τὸν πολιτικὸν καὶ βασιλέα καὶ δεσπότην καὶ ἔτ' οἰκονόμον θήσομεν ὡς ἐν πάντα ταῦτα προσαγορεύοντες, ἢ τοσαύτας τέχνας αὐτὰς εἶναι φῶμεν, ὅσαπερ ὀνόματα ἐρρήθη. "Are we then to identify the statesman with the king, the lord, or the master of a family; or are we to say that there are as many separate arts as we have mentioned names?" The young Socrates is not prepared with an answer, whereupon he is further asked: "What? can there be any difference, as regards government, between a household of large and a town of small dimensions?" (τί δέ; μεγάλης σχῆμα οἰκίσεως, ἢ μικρᾶς αὖ πόλεως ὄγκος μῶν τι πρὸς ἀρχὴν διοίσετον). "There can be none," says the facile respondent. "Is it not then clear," rejoins the other, "that there is but one science applicable to all four, and that it is a mere question of words whether we choose to call such science Kingcraft or Politic or Œconomic?" (εἴτε βασιλικὴν εἴτε πολιτικὴν εἴτε οἰκονομικὴν τις ὀνομάζει μηδὲν αὐτῷ διαφερόμεθα.)

3. There is a passage in Aristotle's treatise *De Partibus Animalium* (I. c. 2), too long for quotation, in which he describes and criticizes that method of division or classification of which the author of this dialogue gives us specimens, styling it *μεσοτομία* or *διχοτομία*, the method of *mesotomy* or *dichotomy*. "Some persons," says Aristotle, "get at particulars by dividing the genus into two differentiæ: but this method is in one point of view difficult, in another impracticable." "It is difficult in this process," he observes, "to avoid discription or laceration of the genus (διασπᾶν τὸ γένος), for example, to avoid classing birds under two distinct heads, an error is committed in the 'written divisions' (γεγραμμένα διαιρέσεις), in which some birds come under the genus Terrestrial, and some under that of Aquatic Animals (ἐκεῖ γὰρ τοὺς μὲν μετὰ τῶν ἐνῶδρων συμβαίνει διηρῆσθαι τοὺς δ' ἐν ἄλλῳ γένει), so that birds and fishes are both classed under the term Aquatic Animals." In a zoological treatise, nothing could have been worse than such a classification; which occurs both in this dialogue and in the *Politicus*¹. Again, in the *Politicus*, 264 A, animals are divided into tame and wild, διήρητο ζύμπαν τὸ ζῶον τῷ τιθάσῳ καὶ ἀγρίῳ. This distinction does not escape Aristotle, who in the treatise referred to, proceeds to observe that a classification of this popular kind mixes up creatures widely diverse in structure (ὥσθ' ὅτιοῦν ζῶον ἐν ταύταις (ταῖς διαιρέσεσιν) ὑπάρχειν), and not only so, but the distinction itself is a conventional one: for nearly all tame animals exist also in a wild state; for instance, man, the horse, the ox,

¹ *Soph.* 220 A: τὸ μὲν πᾶσιν γένους τὸ δ' ἕτερον νευστικῶν ζῶον. *Politic.* 264 C: τῆς μὲν ἀγελαίων τροφῆς ἔστι μὲν ἐνῶδρον, ἔστι δὲ ξηροβατικόν. The words 'written divisions' are supposed to refer to a work now lost, a collection of Pla-

tonic 'Divisions' similar perhaps to that of the 'Definitions' attributed by some to Speusippus, and compiled partly from the Dialogues and partly from Plato's oral teaching.

κύνες ἐν τῇ Ἰνδικῇ, ὕες, αἰγες, πρόβατα. In the Aristotelian treatise itself I am not aware that any system of classification is proposed which would obtain the approbation of modern zoologists. The *Politicus* and the *Sophista* are not zoological works, and Aristotle's censure is therefore irrelevant. But the coincidences seem too special to have been accidental.

4. In a work similar in its scope to the *Sophista*, the curious treatise *περὶ Σοφιστικῶν ἐλέγχων*, occurs a definition of "Sophistic," which to my ear is an echo of the Platonic Dialogue. I allude to the often repeated definition, ἔστιν ἡ σοφιστικὴ φαινόμενη σοφία ἀλλ' οὐκ οὐσα, καὶ ὁ σοφιστὴς χρηματιστὴς ἀπὸ φαινόμενης σοφίας ἀλλ' οὐκ οὐσης (*S. E.* 1. 6). "Sophistic is a wisdom seeming but not real, and the Sophist is a tradesman, whose capital consists of such unreal wisdom." What is this but an abridgment of the *διαρρηκτικὸς λόγος* of the *Sophista*, a definition identical with the νέων καὶ πλουσίων ἔμμισθος θηρευτής—"the hireling hunter of the rich and young," with the very addition which Plato proceeds, with an affectation of logical accuracy, to graft upon it?

5. In the same treatise, c. 5, § 1, we read as follows: "Other paralogisms depend on an ambiguity in the terms employed:—whether they are used absolutely or only in a certain sense: for instance, if you say that "that which 'is not' may be a term in a judgment," they infer the contradiction, 'That which is not, is:' but this is a fallacy, for 'to be this or that' and 'to be' in the abstract are not the same thing. Or conversely, they argue that that which *is*, is not, if you tell them that any entity *is not* so and so—say that A is not a man. For not to be this or that is not the same as absolute non-existence¹."

This is but an Aristotelic translation of the following in the *Sophista*: "Let no one object that we mean by the μὴ ὄν the contrary of the ὄν, when we dare to affirm that the μὴ ὄν is: the truth being, that we altogether decline to say anything about the contrary of the ὄν, whether any such contrary is or is not conceivable by the reason." ἡμεῖς μὲν γὰρ περὶ ἐναντίου τινὸς αὐτῷ (sc. τῷ ὄντι) χαίρειν πολλὰ λέγομεν, εἴτ' ἔστιν εἴτε μὴ λόγον ἔχον ἢ καὶ παντάπασι ἀλογον. p. 258 E.

To this same passage I suppose Aristotle to allude in the *Metaphysica* (vi. 4. 13, Bekk. Oxon.) ἀλλ' ὥσπερ ἐκ τοῦ μὴ ὄντος λογικῶς φασὶ τινες εἶναι τὸ μὴ ὄν οὐχ ἀπλῶς ἀλλὰ μὴ ὄν, κ. τ. λ. (Where λογικῶς = 'sensu dialectico,' as distinguished from φυσικῶς.)

6. I shall have more to say on these passages hereafter: for the present they are mentioned for the sake of the coincidence. The φασὶ τινες, as already observed, is Aristotle's frequent formula of acknowledgment. If any one doubt that the τινές are in this instance a τίς, or if he doubt who the τίς may be, let him hear Aristotle in another part of the same work; διὸ Πλάτωνος τρόπον τινὰ οὐ κακῶς τὴν σοφιστικὴν περὶ τὸ μὴ ὄν ἔταξεν², *Met.* v. 2, § 3, and then turn to the *Sophista*, pp. 235 A, 237 A, 258 B, 264 D, passages which it would be tedious to quote, but the upshot of which is the very distinction to which Aristotle alludes. Add p. 254 A of the same dialogue, where the Sophist is described as "running to hide himself in the darkness of the Non Ens," (ἀποδιδράσκων εἰς τὴν τοῦ μὴ ὄντος σκοτεινότητα), taking

¹ ἀπλῶς τότε ἢ πῶς λέγεσθαι καὶ μὴ κυρίως, ὅταν τὸ ἐν μέρει λεγόμενον ὡς ἀπλῶς εἰρημένον ληφθῆ, οἷον εἰ τὸ μὴ ὄν ἐστὶ δοξαστόν, ὅτι τὸ μὴ ὄν ἐστίν· οὐ γὰρ ταῦτόν ἐστιν αἰετὶ καὶ εἶναι ἀπλῶς. ἢ πάλιν ὅτι τὸ ὄν οὐκ ἐστὶν ὄν εἰ τῶν ἡμετέρων

τι μὴ ἐστίν, οἷον εἰ μὴ ἄνθρωπος.

² "Plato was right to a certain extent, when he represented the Non-ens as the province of the Sophist."

into account that the description occurs in no other part of Plato's writings, and nothing will be wanting to the proof that Aristotle had not only read with attention two dialogues answering to those which bear the titles of the *Sophista* and the *Politicus*¹, but that he knew or believed them to have been written by his Master.

The recognition of a dialogue by Aristotle is at least strong evidence of its genuineness: and it would require stronger internal evidence on the other side to justify us in setting such recognition at defiance². Of the dialogues generally condemned as spurious, some owe their condemnation to the voice of antiquity; others betray by their style another hand; while those of a third class have fallen into discredit on account of the comparative triviality of their matter or the supposed un-Platonic cast of the sentiments they contain. To objections founded on the matter of a suspected dialogue I confess that I attach comparatively little weight, except when they are supported by considerations purely philological. We need have little scruple in rejecting a dialogue so poor in matter and dry in treatment as the Second Alcibiades, when we find the evidence of its spuriousness strengthened by the occurrence of grammatical forms which no writer of the best times would have used³. But it would be rash criticism to condemn the Second Hippias, in which no such irregularities occur, merely because it contains paradoxes apparently inconsistent with other parts of Plato's writings. Tried by this test, the *Lysis* and the *Laches*, and perhaps the *Charmides*, would fare but ill. Yet in them, those who have eyes to see have not failed to recognize the touches of the Master's hand, and the perfection of the form has outweighed the doubtfulness of the matter.

Now I am not aware that *any* philological objections have been urged against the *Sophista*. So far as the mere style is concerned, there is no dialogue in the whole series more thoroughly Platonic. In their structure the periods are those of Plato, and they are unlike those of any other writer. Throughout, as it seems to me, the author is writing his very best. His subject is a dry one; and he strives to make it palatable by a more than ordinary neatness of phrase, and by a sustained tone of pleasantry. His style is terse or fluent, as terseness or fluency is required: but the fluency never degenerates into laxity, nor the terseness into harshness. The most arid dialectical wastes are refreshed by his humour: and bloom in more places than one with imagery of rare brilliancy and felicity. Few besides Plato would have thought of describing the endless wrangling of two sects who had no

¹ I cannot but think that had the Master of Trinity examined the *Politicus* with the same care which he has bestowed on the *Sophista*, he would have formed a different opinion of the genuineness of the two dialogues. The *Politicus* contains passages full not only of Platonic doctrine, but of Platonic idiosyncrasy. I may mention, as a few out of many, the grotesque definition of Man as a "featherless biped" (*Pol.* p. 266 E. 99) which exposed the philosopher to a well-known practical jest: the somewhat wild but highly imaginative mythus, redolent of the *Timæus*, (p. 269 foll.): and, finally, the fierce onslaught on the Athenian Democracy, (p. 299), breathing vengeance against the unforgiven murderers of Socrates. On reading these and similar passages, it would be difficult for the most sceptical to repress the exclamation, "Aut Plato aut Diabolus!"

² The *Sophista* is also recognized, as we have seen, by the vigilant and profoundly learned Simplicius, also by Porphyry (*ap. Simp. ad Phys.* p. 335, *Brandis*). Clemens Alexandrinus and Eusebius quote it as Plato's. If it is not named by Cicero, neither are the *Philebus* and *Theætetus*. The omission of any mention of this latter dialogue by the Author of the *Academic Questions* is really remarkable.

³ e.g. ἀποκριθῆναι for ἀποκρίνασθαι, σκέπτεσθαι for σκοπεῖσθαι. The latter barbarism, I presume, would be defended from *Laches*, p. 185 B. τί ποτ' ἔστι περί οὐ βουλευόμεθα καὶ σκεπτόμεθα, but to me it seems clear that σκεπτόμεθα is an interpretamentum of βουλευόμεθα, which is used in a sense not strictly its own, as in the same passage, *paulo supra*; εἰ ἔστι τις τεχνικός περί οὐ βουλευόμεθα.

principle in common, under the image of a battle between gods and giants; and fewer still, had they conceived the design, would have executed it with a touch at once so firm and so fine. What inferior master could have kept up so well, and with so little effort, the fiction of a hunt after a fierce and wily beast, by which the Eleatic Stranger sustains the ardent Theætetus amid the toil and weariness of a prolonged logical exercitation? Or who could so skilfully have interwoven that exercitation itself with matter so grave and various as that of which the dialogue in its central portion is made up? If vivacity in the conversations, easy and natural transitions from one subject to another, pungency of satire¹, delicate persiflage, and idiomatic raciness of phrase are elements of dramatic power, I know no dialogue more dramatic than the *Sophista*. The absence of any elaborate exhibition of character or display of passion is, under the circumstances, an excellence and not a defect: as such elements would have disturbed the harmony of the composition, and have been as much out of place as in the *Timæus*, or in some of the later books of the *Republic*—to say nothing of the *Cratylus* and *Parmenides*, which resemble this dialogue in so many particulars that those who condemn it, logically give up the other two also.

The *Sophista*, it is well known, is professedly a continuation of the *Theætetus*. The same interlocutors meet, with an addition in the person of an Eleatic Stranger, and they meet by appointment: for at the conclusion of the *Theætetus* Socrates bespeaks an interview for the following day, of which he is reminded by Theodorus in the opening sentence of the *Sophista*. The *Politicus* or Statesman is, in like manner, a professed continuation of the *Sophist*. The connexion, however, between these two is on the surface much closer than that between the *Theætetus* and the *Sophista*. In the *Theætetus* we are not informed what is to be the subject of the next day's talk, but in the *Sophista*² three subjects are proposed for consideration—the *Sophist*, the *Philosopher*, and the *Statesman*; and the choice is left to the new-comer, who selects the *Sophist* as the theme of that day's conversation. The third day is devoted to the *Statesman*, who is made the subject of an investigation similar to that pursued in the case of the *Sophist*. In both dialogues the professed object of the persons engaged is to obtain a definition, and the method pursued is that called by the ancient Logicians, and by the Schoolmen after them, the method of Division. We are left to infer that the *Philosopher* was to be handled on the fourth day in like fashion. Instead of this projected Tetralogy, we have only a Triloggy. No dialogue exists under the title of *Φιλόσοφος*, and the ingenuity of commentators has been taxed to account for the deficiency³. It is tolerably certain that Plato never wrote a dialogue under this title, and it seems idle to speculate on the causes or motives of this omission. It is more to the purpose to observe, that there is no connexion apparent on the surface between the subject-matter of the *Theætetus* and that of

¹ As a specimen of this, take the argument with the *γηγενης*, 246 D, *seq.*, and the mock solemnity with which the 'Ems' of the *ειδῶν φίλοι* is described, 249 A.

² P. 217 A.

³ Schleiermacher, for instance, conceives that the omission is intentional, and that we must look for the missing portrait in the *Symposium* and *Phædo*; of which the first teaches us how a philosopher should live, the latter how he should die. This is

one of those "Schleiermachersche Grillen" which contribute to the amusement even of his admirers. Stallbaum seems to think that the title of the *Parmenides* may originally have been *Φιλόσοφος*, a conjecture which does not seem to me probable, and which I should not have noticed, had it not found favour in the eyes of a gentleman of this University, for whose critical acumen I entertain the greatest respect.

the two succeeding dialogues: and no resemblance between the method of investigation pursued in the *Sophista* and in the *Theætetus*. A definition, it is true, is the professed object of both: the question proposed in the one being, "What is knowledge?" in the other, "What is a Sophist?" Each dialogue is, therefore, a hunt after a definition; but the instruments of the chase are not the same in both instances.

I propose the following as a plausible, though I do not put it up for a certain explanation of the connexion intended by Plato to subsist between the two dialogues.

The art of Definition, it is well known, was an important constituent part of the Platonic Dialectic. It held its ground in the Dialectic of Aristotle, who, however, devotes a larger share of attention to the Syllogism; a branch of Dialectic for which Plato had omitted to give rules. Both are elaborately investigated by the Schoolmen, as by Abelard in his *Dialectice*; nor was it, I believe, until the commencement of this century, or the end of the last, that Definition dropt out of our logic books¹, and the art of Syllogism reigned alone, or nearly alone. Now, in the *Phædrus* of Plato, a dialogue written for the purpose of magnifying the art of dialectic at the expense of its rival, Rhetoric, occurs a passage in which two methods are marked out for the dialectician to pursue in searching for definitions². Either, it is said, he may start from particulars, and from these rise to generals: or he may assume a general, and descend by successive stages to the subordinate species (the species *specialissima*) which contains the thing or idea which he seeks to define. He may begin, to take the example given in the dialogue, with examining the different manifestations of the passion of Love, and after ascertaining what element or elements they possess in common, and rejecting all those in which they differ, he may frame a definition or general conception of Love, sufficiently comprehensive to include its subordinate kinds, and sufficiently restricted to exclude every other passion. Or he may reverse the process, and divide some higher genus into successive pairs of sub-genera or species, until he "comes down" upon the particular kind of Love which he seeks to distinguish. The first of these processes is styled by Plato *συναγωγή*, Collection: by Aristotle *ἐπαγωγή*, Induction: the second is called by both Plato and Aristotle *διαίρεσις*, or the *διαιρητική μέθοδος*, Division, or the Divisive method. Whoso is master of both methods is styled by Plato a Dialectician, and his art, the Art of Dialectic³. We have, therefore, in this passage of the *Phædrus* a Platonic organon in miniature.

Now it so happens, that the *Theætetus* and the *Sophista* pretend, each of them, to be an exemplification of one of these two dialectical methods: the *Theætetus* of a *συναγωγή*, the *Sophista* of a *διαίρεσις*⁴. It is this fiction which gives life and unity of purpose to the *Theæ-*

¹ It was first re-instated, so far as I know, by Mr Mill.

² See Appendix I. *Phædr.* 265 D, foll.

³ Those who are unskilled in the application of these processes are termed *ἐριστικοί* in the *Philebus*, 16 E. οἱ δὲ νῦν τῶν ἀνθρώπων σοφοὶ ἐν μὲν, ὅπως ἂν τύχῃσι, καὶ θᾶττον καὶ βραδύτερον ποιούσι τοῦ δέοντος μετὰ δὲ τὸ ἐν ἄπειρα εὐθύς· τὰ δὲ μέσα αὐτοῦς ἐκφεύγει· οἷε διακεχώρισται τὸ τε διαλεκτικῶς πάλιν καὶ τὸ ἐριστικῶς ἡμᾶς ποιῆσθαι πρὸς ἀλλήλους τοὺς λόγους. It is needless to enlarge on the importance of this quotation towards the illustration of the

Sophista, as well as of the passage from the *Phædrus* now under review. In the received text we read καὶ πολλὰ θᾶττον, κ.τ.λ. The sense manifestly requires the omission of πολλὰ. The Eristics admit a One and an Infinite: the Platonists divide the One into Many, and define the number of the Many (*Phileb. paulo supra*). In other words, they employ the method of Division or Classification, as well as that of Collection or Induction.

⁴ Compare *Theæt.* 145 D—148, with *Sophista, initi.* and 253, §§ 82, 83, Bekk.

tetus, a dialogue which is in reality a critical history of Greek psychology as it existed down to the fourth century, just as the *Sophista* is virtually a critique of the logic or dialectic of the same and previous eras. The one dialogue exposes the unsoundness or incompleteness of the mental theories of Protagoras, of the Cyrenaics, whose founder Aristippus was Plato's contemporary and rival, and perhaps of certain other schools whose history is less known to us¹. The *Sophista*, in like manner, passes under review the logical schemes of the Eleatics, of their admirers, the semi-Platonic Megarians, and finally of Antisthenes and the Cynics. Both dialogues, as I have said, profess to be at the same time exemplifications of the processes which the true dialectician, or, as he is styled in the *Sophista*, 216 κ, 253 D, the true philosopher must adopt in his search for scientific truth. The one is a hunt after the true conception of ἐπιστήμη or science, the other an investigation of the genus and differentiæ of the conception implied in the term Sophist; and this fiction² serves in both cases to bind together the critical and polemical investigations which make up the main body of either dialogue. It lends to each the unity of an organic whole³; and infuses into a critical treatise on an abstruse branch of philosophy the vivacity and interest of a drama. Add to this, that the *Sophistu* helps materially towards a solution of the question, What is Science? which is the professed aim of the dialogue which precedes it. It attains this object in two ways. First, by enlarging the conception of that which is *not* Science, treating the subject on its logical or dialectical, as the *Theætetus* regarded it chiefly on its real or psychological side: and, secondly, by giving rules, illustrated by example, for what Plato considered, as we have seen, one of the main elements of scientific method. And the same analogy holds in respect of the critical or controversial portion of either dialogue. As in the *Theætetus* it is shewn that the Protagorean dictum, that Truth exists only relatively to its percipient (πάντων μέτρον ἄνθρωπος), and the kindred, though not identical Cyrenaic dogma, that sense is knowledge, and the sensations the sole criteria of truth (κριτήρια τὰ πάθη), so far from furnishing tenable definitions of Science, in effect render Science impossible: so in the *Sophista* the Logic of the Cynics and Eleatics is proved to be more properly an Anti-logic, annihilating all Discourse of Reason, and rendering not only Inference but Judgment, or the power of framing the simplest propositions, a sheer impossibility.

I have said that the *Sophista* is first a dialectical exercitation, and secondly a critique more or less hostile of three rival systems of dialectic; two of which, it may be added, evidently sprang out of the third, and presuppose, if they do not assert, the false assumptions on which that third is founded. It may conduce to greater clearness if I take this critical portion of the dialogue first in order. In defending my position, I shall make no assertions at second hand; an indulgence to which there is the less temptation, as Plato himself tells us pretty plainly what he means, and where *he* fails us, Aristotle and the ancient historians of Philosophy supply all that is wanting.

¹ The theory that "Science is right Opinion combined with Sensation" is given by Zeller to Antisthenes on grounds which seem highly probable.

² I would not be understood to mean that the pursuit of the Definition is a mere feint in either case, but only that it serves as a πρόφασις—a natural and probable occasion for the introduction of important controversial discussions. It constitutes

the framework or "plot" of the drama. At the same time I conjecture that the end Plato had most at heart in these two dialogues was the confutation of opponents. In the *Politicus*, on the other hand, a didactic or constructive intention appears to predominate.

³ Comp. *Phædr.* 264 c: δαί πάντα λόγον ὡσπερ ζῶου συνεστάναι, κ. τ. λ.

The oldest, and in the history of Speculation the most important, of these three schools was the Eleatic, founded, as the Stranger from Elea tells us in this dialogue, by Xenophanes¹, though its doctrines underwent some modification, and received extensive development in the hands of Parmenides and Zeno, his successors. When Plato wrote this dialogue, there is every reason to suppose that the Eleatic school had ceased to exist. The latest known successor of Parmenides, Melissus, flourished, as the phrase is, about the year B.C. 440, and Zeno is placed a few years earlier. The earliest date which it is possible to assign to the *Theætetus*, and *à fortiori* to the *Sophista*, is about 393.² There can therefore be no question of an Eleatic author of this dialogue, an "opponent of Plato," resident in Athens, and writing in the Attic dialect. Socrates may have had such opponents, though we read of none; but the hypothesis is inadmissible in the case of his disciple.

The Eleatic Stranger however leaves us in no doubt of his intentions. In the course of his investigation of the attributes of the Sophist, he is on the point of obtaining from Theætetus an admission that his, the Sophist's, art is a fantastic and unreal one: but he affects to hesitate on the threshold of this conclusion, because, as he says, "The Phantastic Genus," to which they are about to refer the Sophist, is one difficult to conceive; and the fellow has very cunningly taken refuge in a Species the investigation of which is beset with perplexity³. Theætetus assents to this mechanically, but the Stranger, doubting the sincerity of his assent, explains his meaning more fully. The word *φανταστικός* implies that a thing may be *not* that which it seems, and it is a question with certain schools whether there is any meaning in the phrase, to say or think that which is false, in other words, that which is *not*: for, say they, you imply by the phrase that that which is not, *is*—that there exists such a thing as non-existence: and thus you involve yourself in a contradiction⁴. But if we assert that 'Not-being is' (*quod Non Ens est*.) then, says the speaker, "we fly in the face of my Master, the great Parmenides, who both in oral prose and written metre adjured his disciples to beware of committing themselves to this contradiction⁵. To extricate ourselves then from the *ἀπορία* in which the Sophist has contrived to plant us, it is necessary," proceeds the Stranger, "to put this dictum of our Father Parmenides to the torture, and to extort from it the confession that the contra-

¹ *Soph.* 242 D: τὸ δὲ παρ' ἡμῶν Ἑλεατικὸν ἔθνος ἀπὸ Ξενοφάνους...ἀρξάμενον.

² Apuleius, *de Dogm. Plat.* 569, says that Plato took up the study of Parmenides and Zeno (*inventæ Parmenidis et Zenonis studiosius executus*) after his second visit to the Pythagoreans in Italy: having been compelled to give up his intention of visiting Persia and India by the wars which broke out in Asia at the time. Does this imply that he visited Elea instead? If so, and if he composed the *Sophista* and its sister-dialogues on his return, we obtain a clue to the fiction of an Eleatic Stranger. He was Plato, on his return from a sojourn at Elea, laden, it may be, with Eleatic lore.

The circumstance that the conduct of the dialogue devolves upon this Stranger is pointed to as one proof that the *Sophista* was not written by Plato, whose custom is to make Socrates his Protagonist. The secondary part which Socrates plays in

the *Timæus* and his entire absence from the colloquy in the *Laws* seem fatal to the major premiss in this reasoning. It should also be observed, that the author of the *Sophista*, if not Plato, took pains to pass himself off as Plato: else why did he tack on the *Sophist* to the *Theætetus*? But if the author of the *Sophista* wished to pass for Plato, why did he deviate from Plato's ordinary practice, by putting a foreigner from Elea into the place usually occupied by Socrates?

³ Ἐπεὶ καὶ νῦν μάλ' εὖ καὶ κομψῶς εἰς ἀπορον εἶδος διερευνησασθαι καταπέφευγεν. 236 D.

⁴ Τετόλμηκεν ὁ λόγος οὗτος ὑποθέσθαι τὸ μὴ ἂν εἶναι ψεῦδος γὰρ οὐκ ἂν ἄλλως ἐγίγνετο ἂν. 237 A.

⁵ Ἀπεμαρτύρατο περὶ τε ὅδε ἐκάστοτε λέγων καὶ μετὰ μέτρων·

οὐ γὰρ μήποτε τοῦτο δαῖς, εἶναι μὴ ἔοντα, ἀλλὰ σὺ τῆσδ' ἀφ' ὁδοῦ διζήσεις εἶργε νόημα. *Ib.*

diction is in fact no contradiction, but that there is a sense in which the *μη ὄν* *is*, and in which the *ὄν* *is not*¹." In this passage the Eleatic, who is Plato's mouthpiece, formally declares war against the logical system of his master Parmenides, in one of its most vital parts. His words, I conceive, admit of no other explanation. A question here suggests itself as to the meaning of this Eleatic denial of the conceivableness of non-entia. "You can never learn," says Parmenides, "that things which are not are²." Does he mean to forbid the use of negative propositions? His words will bear, I think, no other sense, and so, as we shall see, Plato understands them. In fact two misconceptions, both arising from the ambiguity of language, seem to lie at the root of the Eleatic Logic. Parmenides first confounds the verb-substantive, as a copula, with the verb-substantive denoting Existence or the Summum Genus of the Schoolmen. He secondly assumes that in any simple proposition the copula implies the identity of subject and predicate, instead of denoting an act of the mind by which the one is conceived as included in the other, in the relation of individual or species to genus. It may seem strange that so great a man should have thus stumbled in limine. But enough is left of his writings to enable us to perceive that he was notwithstanding a profound, or if that be questioned, certainly a consistent thinker. In the first place he altogether repudiates the distinction of 'subjective' and 'objective.' "Thought," he says, "and that for which thought exists are one and the same thing³;" and more distinctly still, "Thought and being are the same," τὸ γὰρ αὐτὸ νοεῖν ἐστίν τε καὶ εἶναι: and, χρῆ τὸ λέγειν τε νοεῖν τ' εὐὸν ἔμμεναι⁴, "Speech and thought constitute reality." A man who thus thought must therefore have repudiated the antithesis between Logic and Physics, between Formal and Real Science, a distinction which appears to us elementary and self-evident. Logic was to Parmenides Metaphysic, and Metaphysic Logic. That which is conceivable alone *is*, and that *is* which is conceivable. The abstraction "To Be" is the same as Absolute Existence. The "Ens logicum" and the "Ens reale" are the same thing. The only certain proposition is the identical one "Being is," for "not-Being is Nothing⁵." Hence the Formula which served as the Eleatic watchword: ἐν τὰ πάντα, "unum omnia."

If it be asked, what did Parmenides make of the outward universe? we are at no loss for an answer. He denied its claim to reality, or any participation of reality, in toto⁶. And on the principles of his Logic he was bound so to do. For every sensible object, or group of sensible objects, being distinct from every other object or group of objects, is at once an Ens and a Non-ens, it is *this* and it is *not that*, e. g. If Socrates is a man, Socrates is not a beast: for the genus "man" excludes the genus "beast." (ἄνθρωπος ἐστὶ μὴ θήριον, as Parmenides would have expressed it.) But a *μη θήριον* is, according to his logic, a *μη ὄν*; therefore all so-called ὄντα are at the same time *μη ὄντα*: non-existent, and therefore inconceivable, and so altogether out of the domain of Science.

¹ Τὸν τοῦ πατρὸς Παρμενίδου λόγον ἀναγκαῖον ἡμῖν ἀμνημονέμενοι ἐστὶν βασιανίζειν, καὶ βιάζεσθαι τό τε μὴ ὄν ὅτι ἐστὶ κατὰ τι, καὶ τὸ ὄν αὐτὸ πάλιν ὅτι ἐστὶ πη. p. 241 D. Comp. Arist. *Soph. El.* c. 5, § 1, quoted above.

² οὐ γὰρ μήποτε τοῦτο δαῖς, εἶναι μὴ ἔόντα.

³ ταῦτόν δ' ἐστὶν νοεῖν τε καὶ οὐνεκὲν ἐστὶ νόημα. *Frag.*

v. 94, Mullach.

⁴ *Frag.* v. 43, ed. Mullach.

⁵ἐστὶ γὰρ εἶναι, μὴδὲν δ' οὐκ εἶναι.

..... οὐδὲν γὰρ ἢ ἔστιν ἢ ἐστὶν

"Ἄλλο παρὰ τοῦ ἔόντος. *Ibid.*

⁶ *Ibid.* v. 110.

From the dicta of Parmenides which I have been endeavouring to explain, the Eleatic Stranger in the dialogue proceeds to deduce various conclusions: the most startling of which is, that Being is, on Eleatic principles, identical with Not-being,—that the worship $\delta\upsilon\nu$ is after all a pitiful $\mu\eta\ \delta\upsilon\nu$! He is enabled to effect this *reductio ad absurdum* by the incautious proceeding of Parmenides, who instead of entrenching himself in the safe ground of an identical proposition, and thence defying the world to eject him, must needs invest his Ens with a variety of attributes calculated to exalt it in dignity and importance. It is “unbegotten,” it is “solitary,” it is “immoveable,” it is “a whole,” it is even “like unto a massive orbéd sphere².” (*Soph.* 246 E.) In one of these unguarded outworks the Stranger effects a lodgment, and by a series of well-concerted dialectical operations, succeeds, as we have seen, in carrying the citadel.

Having shewn the Nothingness of the Eleatic Ontology, the Stranger proceeds to pass in review two other systems of speculative philosophy. “We have now,” he says, “discussed—not thoroughly it is true, but sufficiently for our present purpose, the tenets of those who pretend to define strictly the $\delta\upsilon\nu$ and the $\mu\eta\ \delta\upsilon\nu$: we must now take a view of those who talk differently on this subject. When we have done with all these, we shall see the justice of our conclusion that the conception of Being is involved in quite as much perplexity as that of Not-being³.” Of one of the two sects who “talk differently,” I venture to hold an opinion varying from that generally received—an opinion formed many years ago in opposition to that advanced by Schleiermacher and adopted without sufficient consideration by Brandis, Heindorf and others. Careful students of Plato are aware that his dialogues abound with matter evidently polemical, to the drift of which his text seems on the surface to offer no clue. I mean that, like Aristotle, he frequently omits to name the philosophers whose tenets he combats: characterising them, at the same time, in a manner which to a living contemporary, versed in the disputes of the schools and personally acquainted with their professors, would at once suggest the true object of his attack⁴. Such well-informed persons constituted doubtless the bulk of Plato’s readers and formed the public for whom he principally wrote. It was they who applauded or writhed under his sarcasms, as they happened to hold with him or his adversaries. It is to place himself in the position of this small but educated public that the patient student of Plato should aspire: neglecting no study of contemporary monuments, and no research among the scarcely less valuable notices which the learned Greeks of later times have left scattered in their writings. Of these notices, emanating originally from authorities

¹ *Soph.* 245 c, 964 Bekk.: $\mu\eta\ \delta\upsilon\tau\omicron\varsigma\ \delta\acute{\epsilon}\ \gamma\epsilon\ \tau\omicron\ \pi\alpha\rho\acute{\alpha}\pi\alpha\nu\ \tau\omicron\upsilon\ \delta\iota\lambda\omicron\upsilon,\ \tau\alpha\upsilon\tau\acute{\alpha}\ \tau\epsilon\ \tau\alpha\upsilon\tau\acute{\alpha}\ \delta\eta\rho\acute{\alpha}\chi\epsilon\iota\ \tau\tilde{\omega}\ \delta\upsilon\tau\iota,\ \kappa\alpha\iota\ \pi\rho\acute{\omicron}\varsigma\ \tau\tilde{\omega}\ \mu\eta\ \epsilon\iota\upsilon\alpha\iota\ \mu\eta\delta\ \acute{\alpha}\nu\ \gamma\epsilon\upsilon\acute{\epsilon}\sigma\theta\alpha\iota\ \kappa\omicron\tau\acute{\epsilon}\ \delta\upsilon\nu.$

² $\pi\acute{\alpha}\nu\tau\omicron\upsilon\theta\epsilon\nu\ \epsilon\upsilon\kappa\lambda\omicron\nu\ \sigma\phi\acute{\alpha}\iota\rho\eta\varsigma\ \acute{\epsilon}\nu\alpha\lambda\acute{\iota}\gamma\kappa\iota\omicron\nu\ \delta\gamma\kappa\phi.$ *Par.* v. 103.

³ $\Upsilon\upsilon\ \acute{\epsilon}\kappa\ \pi\acute{\alpha}\nu\tau\omega\nu\ \acute{\iota}\delta\omega\mu\epsilon\nu\ \delta\upsilon\tau\iota\ \tau\omicron\ \delta\upsilon\nu\ \tau\omicron\upsilon\ \mu\eta\ \delta\upsilon\tau\omicron\varsigma\ \omicron\upsilon\delta\acute{\epsilon}\nu\ \epsilon\upsilon\pi\omicron\rho\acute{\omega}\tau\epsilon\rho\omicron\nu\ \acute{\epsilon}\iota\pi\epsilon\iota\nu\ \delta\ \tau\acute{\iota}\ \kappa\omicron\tau\ \acute{\epsilon}\sigma\tau\iota\nu.$ p. 245 E.

⁴ This reticence, of which it is not difficult to divine the motives, is most carefully practised in the case of the living celebrities who claimed like himself to be disciples of Socrates, such as Euclides, Aristippus and Antisthenes. A cursory reader of Plato has no conception that such men existed as the heads of rival sects with which the Platonists of the Academy

were engaged in perpetual controversy. On the other hand, Plato never scruples to name the dead, nor perhaps those living personages with whom he stood in no relation of common pursuits or common friendships, e.g. Lysias, Gorgias, &c. The Pythagoreans, though remote in place, were his friends and correspondents, and in speaking of them he observes the same rule as in the case of his living Athenian contemporaries, indicating without expressly naming them. Thus, in the *Politicus*, p. 285, they are merely denoted as *κομψοί*, “ingenious persons.” This, by the way, is a passage of great importance, as indicating the limits within which Plato “pythagorized,” and the particulars in which he dissented from his Italic friends.

contemporary or nearly contemporary with the philosopher himself, many have been embalmed in the writings of Eusebius and Sextus Empiricus, the Aristotelian Commentators, Cicero, and others: not to mention the vast store of undigested learning amassed by Diogenes Laertius.

Now of the two sects who here come under revision, and who enact the part of Gods and of Giants in the famed Gigantomachy¹, which is familiar to most readers of Plato, the occupants of the celestial regions are rightly, as I think, judged to mean the contemporary sect of the Megarics. They are idealists in a sense, but their idealism is not that of Plato. They so far relax the rigid Eleatic formula "unum omnia" as to admit a plurality of forms (εἶδη or ὄντα or οὐσία). They are complimented in the dialogue as ἡμερώτεροι, "more civilized" or "more humane," than their rude materialistic antagonists: but they are at the same time taken sharply to task by the Eleatic Stranger: and for what? For the absence, from their scheme of Idealism, of that very element which constitutes the differentia of the Platonic Idealism. "They refuse to admit," says the Stranger, "what we have asserted concerning substance, in our late controversy with their opponents:" οὐ συγχωροῦσιν ἡμῖν τὸ νῦν δὴ ρηθὲν πρὸς τοὺς γηγενεῖς οὐσίας πέρι, 248 B; the thing they refuse to admit being neither more nor less than that κοινωνία or μέθεξις τῶν εἰδῶν², which Aristotle cannot or will not understand in his critique of the Platonic Doctrine of Ideas. Like Plato, they distinguish the two worlds of sense and pure ideas, the γένεσις from the οὐσία (γένεσιν τὴν δὲ οὐσίαν χωρὶς που διελόμενοι λέγετε, 248 A), but, unlike him, they deny that the one acts or is acted upon by the other: they even deny that Being (εἶδη or οὐσία) can be said to act or suffer at all; nay, when pressed, they seem to admit that it is impossible to predicate of it either knowledge or the capacity of being known³. The arguments by which the "Friends of Forms" (εἰδῶν φίλοι, 248 A) are pushed to this admission may not ring sound to a modern ear; but my business is not with the soundness of Plato's opinions, but with their history: and it would be easy to produce overwhelming evidence both from his own writings and those of Aristotle to the truth of the statement, that however the phrase is to be interpreted, there is, according to Plato, a fellowship, κοινωνία, between the world of sensibles and the world of intelligibles, and that the conception of this fellowship or intercommunion distinguishes his Ideal Scheme from that of the Eleatics⁴, and, as appears from this passage, from that of the semi-Platonic school

¹ *Soph.* 246 A, § 65 Bekk.

² Aristotle objects to the term μέθεξις on the ground that it is metaphorical. Now as a logical term, the Platonic μέθεξις is but the counterpart of ὑπαρξις, the Aristotelian word denoting the relation of subject to predicate. The one term is as metaphorical as the other, and not more so. "A belongs (ὑπάρχει) to B" and "B partakes of A" (μετέχει) are both in a sense metaphorical phrases, and the metaphor employed is the same in both cases. The Platonic term marks the relation between subject and predicate as *not* one of identity, and thus serves to distinguish the Dialectic of Plato from that of the Eristics, who denied that the "One" includes a "Many." The same purpose is equally well, but not better answered by the ὑπάρχει of Aristotle.

³ Τὴν οὐσίαν δὲ κατὰ τὸν λόγον τοῦτον γινωσκόμενην ὑπὸ τῆς γνώσεως, καθ' ὅσον γιγνώσκειται κατὰ τοσοῦτον κινεῖσθαι διὰ τὸ πάσχειν, ὃ δὴ φάμεν οὐκ ἔν γεγενῆσθαι περὶ τὸ ἡρεμοῦ. p. 248 E.

⁴ Compare 249 D, § 75: τῷ δὲ φιλοσόφῳ καὶ ταῦτα μάλιστα τιμῶντι πᾶσα ὡς εἰκεν ἀνάγκη διὰ ταῦτα μήτε τῶν ἐν ἢ καὶ τὰ πολλὰ εἶδη λεγόντων τὸ πᾶν ἐστηκόσ ἀποδέχεσθαι, τῶν τ' αὖ πανταχῇ τὸ ἐν κινούντων μηδὲ τὸ παράπαν ἀκούειν, ἀλλὰ κατὰ τὴν τῶν παίδων εὐχὴν, ὅσα (ὡς?) ἀκίνητα καὶ κεκινημένα, τὸ ἐν τε καὶ τὸ πᾶν, ζυναμφότερα λέγειν. This passage, as I understand it, expresses Plato's dissent alike from the Eleatics and Megarics, and from those Ephesian followers of Heraclitus whom he had discussed in the *Theætetus*. This is not the only echo of that dialogue heard in the *Sophista*.

of Megara also¹. I will only add, that the passage on which I have been commenting deserves, in my opinion, a more careful study and closer analysis than it has yet received, and I shall be very thankful for any remarks in elucidation of it which may be contributed either by those who agree with my notions of its general import, or by those who take a totally opposite view².

We pass now from the heavenly to the earthly; from the serene repose of the transcendentalists, μάλα εὐλαβῶς ἄνωθεν ἐξ ἀοράτου ποθὲν ἀμυνομένων, to the violence and fury of the giant brood below, who seek to eject these divinities from their august abodes, "actually hugging rocks and trees in their embrace," ταῖς χερσὶν ἀτεχνῶς πέτρας καὶ δρῦς περιλαμβάνοντες, 246 A.

Of these materialists—for such in the coarsest sense of the word they are—I remark, first, that they are evidently the same set of people as those described in terms almost identical by Plato in the *Theætetus*, p. 155 E. At this point of the last-named dialogue Socrates is about to expound the tenets of the Ephesian followers of Heraclitus; whose sensational theory, as he afterwards shews, agrees with that of the Cyrenaics in essentials, though it was combined with cosmical or metaphysical speculations in which it may be doubted whether they were followed by the Socratic sect. Before, however, he enters upon these highflown subtleties, he humorously exhorts Theætetus to look round and see that they were not overheard by "the uninitiated:" "those," he says, "who think nothing real, but that which they can take hold of with both hands³; those who ignore the existence of such things as 'actions,' and 'productions,'—in a word, of anything that is not an object of sight," (πᾶν τὸ ἀόρατον οὐκ ἀποδεχόμενοι ὡς ἐν οὐσίας μέρει). These persons are garnished with the epithets "hard," "stubborn," "thoroughly illiterate," σκληροὶ—ἀντίτυποι—μάλ' εὖ ἄμυνοσι.

Now the only contemporary philosopher to whom these epithets of Plato are applicable is the founder of the Cynic school, Antisthenes, a man whose nature corresponded with his name, and to whose name, as well as to his nature, the ἀντίτυπος of the *Theætetus* would be felt to convey an allusion "intelligible to the intelligent." The μάλ' εὖ ἄμυνοσι finds its echo in the synonymous epithet ἀπαίδευτοι, which Aristotle in the *Metaphysica* bestows on Antisthenes and his followers⁴. Every one, however, must see, without further argument, that the description in the *Theætetus* tallies in all points with that in the *Sophista*, and that both are in perfect agreement with what we know from Diog. Laertius and a host of others, of the moral characteristics of the Cynic school⁵. The materials of the comparison may be found in

¹ This epithet I conceive to be justified by Cicero's notice, "Hi quoque (sc. Megarici) multa a Platone," *Acad. Qu.* II. 42, and also by the brief statement of the Megaric dogmas which Cicero gives us in the context of this passage.

² In the *Philebus*—a dialogue which treats of the relation of οὐσία to γένεσι: in its moral and physical, that is to say its real, in distinction from the purely logical or formal aspect under which it is presented in the *Sophista*—Plato postulates a Tetrad, composed of the principles he there denotes as Limit, the Unlimited, the Mixed or Concrete, and Cause. The third principle he denominates γένεσις εἰς οὐσίαν, the possibility of which process is precisely what the εἰδῶν φίλοι—the pure

idealists of this dialogue—deny. *Phileb.* p. 24, foll. The distinctness of the Causal Principle from the Ideas is clearly laid down in the *Philebus*, and is recognized in the *Sophista* also, p. 265, §§ 109, 110.

³ Compare *Soph.* 247 C: διαπεινοῦντ' ἂν πᾶν ὃ μὴ δυνατοὶ ταῖς χερσὶ ξυμπιέζειν εἰσὶν ὡς ἄρα τοῦτο οὐδὲν τὸ παράπαν ἐστίν.

⁴ VII. 3. 97: οἱ Ἀντισθένηοι καὶ οἱ οὕτως ἀπαίδευτος.

⁵ I have shewn in Appendix II. that the only other schools who can in fairness be called "materialists," are out of the question here.

any manual of the history of philosophy. For our present purpose it were to be wished that some portion of the voluminous writings of Antisthenes had been preserved, in addition to the meagre declamations, if they are really his, which are commonly printed with the *Oratores Attici*. The notices, however, which Aristotle and his commentators have preserved to us, countenance the assumption just made, that the Earth-born are the Cynics. Hatred of Plato and the Idealists seems to have been the ruling passion of Antisthenes, and this passion drove him into the anti-Platonic extremes of Materialism in Physics, and an exaggerated Nominalism in Dialectic. "He could not see Humanity, but he could see a Man," is one of his recorded sarcasms upon the doctrine of ideas¹. "Your body has eyes, your soul has none," was the curt reply of Plato. Many other stinging pleasantries were interchanged by the leaders of the two schools: and Antisthenes, less guarded than his antagonist, wrote a dialogue "in three parts," entitled *Σάθων*, which was avowedly directed against Plato in revenge for a biting reply (Diog. Laert. III. § 35; VI. § 16). The subject of this dialogue has been recorded, and it is not a little curious that it was written to disprove the very position which Plato devotes a large proportion of the *Sophista* to establishing; viz. that there is a sense in which "the Non-ens is," in other words, that negative propositions are conceivable. Antisthenes maintained in this book, *ὅτι οὐκ ἔστιν ἀντιλέγειν*. If we add, that he also wrote four books on Opinion and Science (*περὶ δόξης καὶ ἐπιστήμης*), we shall hardly think the conjecture extravagant, that the remainder of this dialogue is, in the main, a critique of the Cynical Logic. Another paradox of this school, closely connected with the last, is recorded by Aristotle², and sarcastically noticed at page 251 B of the *Sophista*, in terms which leave little doubt as to the object of Plato's satire. If Antisthenes really pushed this paradox to its legitimate results—and from the character of the man it is not unlikely he did—he must be understood as maintaining that identical propositions are the only propositions which do not involve a contradiction: a theory which, as Plato shews, renders language itself impossible³, as well as that inward "discourse of reason⁴," of which language is the antitype.

The resemblance of the Cynical Logic to the Eleatic is usually accounted for by the circumstance that Antisthenes had been a hearer of Gorgias, who wrote a treatise, preserved or

¹ Tzetzes, *Chil.* VII. 605; Schol. in *Arist. Categ.* ed. Brandis, p. 66 δ, 45 and 68 δ, 26; Zeller, *G. P.* II. p. 116, note 1.

² *Metaph.* v. 29: Ἀντισθένης ὡστο εὐήθως μὴθὲν ἀξίων λέγεσθαι πλὴν τῷ οικείῳ λόγῳ ἐν ἐφ' ἐνός· ἐξ ὧν συνέβαινε μὴ εἶναι ἀντιλέγειν, σχεδὸν δ' οὐδὲ ψεῦδεσθαι. Plat. *Soph.* I. 1.: οὐκ ἔωντες ἀγαθὸν λέγειν ἀνθρώπου, ἀλλὰ τὸ μὲν ἀγαθὸν ἀγαθὸν τὸν δὲ ἀνθρώπου ἀνθρώπου. The latter passage explains the *οικείῳ λόγῳ* of Aristotle, and the allusion is further determined by the *ἀμούσου τινὸς καὶ ἀφιλοσόφου* applied to the upholder of the similar sophisms noted at p. 259 D. In the latter passage occur the following words: οὐ τέ τις ἐλεγχος οὗτος ἀληθινός, ἄρτι τε τῶν ὄντων τινὸς ἐφαπτομένου δηλὸς νεογενῆς ὢν. "This is no genuine or legitimate confutation: but the infant progeny of a brain new to philosophical discussion." This hangs together with the *γερόντων τοῖς ὄψιμαθέσι*—"the old gentlemen who have gone to school late in life," p. 251 B, and both passages are illustrated by a notice in Diog. Laert. VI. I, *init.* that Antisthenes, having been originally a hearer of Gorgias, became at a later period a disciple of Socrates,

and brought with him as many of his pupils as he could induce to follow his example. A similar sarcasm is hurled at Dionysodorus and Euthydemus, in the *Euthyd.* p. 272 C, which not improbably was designed to glance off from them upon some contemporary Eristic. Antisthenes, we know, was present at the battle of Tanagra, in B. C. 426. He may therefore have been Plato's senior by some 20 years.

³ καὶ γὰρ ὦ γὰθὲ, τό γε πᾶν ἀπὸ παντὸς ἐπιχειρεῖν ἀποχωρεῖν, ἄλλως τε οὐκ ἐμμελὲς καὶ δὴ καὶ παντάπασιν ἀμούσου τινὸς καὶ ἀφιλοσόφου. Θ. τί δὴ; Ψ. τελειοτάτη πάντων λόγων ἐστὶν ἀφάνισις τὸ διαλύειν ἕκαστον ἀπὸ πάντων διὰ γὰρ τὴν ἀλλήλων τῶν εἰδῶν συμπλοκὴν ὁ λόγος γέγονεν ἡμῖν. *Soph.* 259 D.

⁴ διάλογος ἄνευ φωνῆς γιγνόμενος ἐπωνομάσθη διάνοια. *Soph.* 263 E. Van Heusde first pointed out the infamous etymology lurking in this passage (*διάνοια* = *διάλογος* ἄνευ). The sentiment, without the etymology, occurs in *Theat.* 189 E: (τὸ δὲ διανοεῖσθαι καλῶ) λόγῳ δὲ αὐτῆ πρὸς αὐτὴν ἢ ψυχῇ διεξέρχεται περὶ ὧν ἂν σκοπῆ.

epitomized by Aristotle, in which the paradoxes of Parmenides and Zeno are put forward in their most paradoxical form, and pushed to their consequences with unflinching consistency. Gorgias was also a speculator in physics, and so was Antisthenes¹; in whom, moreover, we may observe other characteristics of those accomplished men of letters of the fifth century, who are usually called "the Sophists." His ethical opinions on the other hand were borrowed from Socrates; but in passing through his mind they took the tinge of the soil, and seem to the common sense of mankind as startling as any of his dialectical paradoxes. It is remarkable, however, that when Plato handles the Cynical Ethics, he treats their author with far more leniency than in this dialogue. In comparing it with the Pleasure Theory of Aristippus, he speaks of the Cynical system with qualified approbation. *Δυσχερής*², "austere or morose," is the hardest epithet he flings at Antisthenes in the *Philebus*: he even attributes to him a certain nobleness of character (*φύσει οὐκ ἀγεννή*), which had led him, as Plato thought, to err on the side of virtue. The *Philebus* is a work of wider range and profounder bearings than the *Sophista*, but the dialogues have this in common, that in both the broad daylight of reason is shed on regions which had been darkened by the one-sided speculations or the wilful logomachy of earlier or inferior thinkers. The way in which Antisthenes is dragged from his hiding-place among the intricacies of the Non-existent into the light of common-sense, at the close of the present dialogue, appears to me an admirable specimen of controversial ability; and the broad and simple principles on which Plato founds the twin sciences of Logic and Grammar³ stand in favourable contrast to the sophistical subtlety of his predecessors and contemporaries.

At this point of the discussion I would gladly stop: but I feel bound to say a few words on what I have ventured to call the "logical exercise," which is the pretext under which Plato takes occasion to dispose of the doctrines of certain formidable antagonists. That the *διαρηκτικοὶ λόγοι*, the "amphiblestic organa⁴," in which he endeavours to catch and land first the Sophist and then the Statesman, were regarded by Plato himself in this light, we learn from his own testimony in the *Politicus*, 285 D, § 26 Bekk. "Is it," asks the Eleatic Stranger, "for the Statesman's sake alone, that this long quest has been instituted, or is it not rather for our own sake, that we may strengthen our powers of dialectical enquiry upon subjects in general? S. J. It was doubtless for this general purpose. E. S. How much less then would a man of sense have submitted to a tedious enquiry into the definition of the art of weaving, if he had no higher object than that!" He then proceeds to apologize for the prolixity of this method of classification: but adds, "The method which enables us to distinguish according to species, is in itself worthy of all honour; nay, the very prolixity of an investigation of this kind becomes respectable, if it render the hearer more inventive. In that

¹ Hence the explanation of *Philebus*, 44 B: *καὶ μάλᾳ δεινούς λεγομένους τὰ περὶ φύσιν.*

² *Phil.* 44 C: *μαντευομένοις οὐ τέχνη ἀλλὰ τιμὴ δυσχερεῖα φύσεως οὐκ ἀγεννοῦς, λαν μεμσηκότων τὴν τῆς ἰσοονῆς δύναμιν, καὶ νενομικώτων οὐδὲν ἕγιές.....σκεψάμενος ἔτι καὶ τὰλλα αὐτῶν δυσχεράσματα. Ib. D: κατὰ τὸ τῆς δυσχερείας αὐτῶν ἴχθος.* The accomplished and unfortunate Sydenham first pointed out the reference in these epithets to the Cynics and their master. The *οὐ τέχνη* of Plato tallies

with the *ἀπαίδευτοι* of Aristotle, and with his own *ἄμωσοι*, &c.

³ P. 262 D. Simple as the analysis of the Proposition into *ὄνομα καὶ ῥῆμα* (subject and predicate in logic, noun and verb in grammar) may seem to a modern reader, it appears to have been a novelty to Plato's contemporaries. Plutarch expressly attributes the discovery to Plato (*Plat. Qu.* v. l. 108, *Wyttenb.*), Apuleius, *Doctr. Plat.* III. p. 203. Comp. *Plat. Crat.* 431 B.

⁴ *Soph.* 235 B.

case we ought not to be impatient, be the enquiry short or long." If we say it is too long, "we are bound to shew that a shorter discussion would have been more effectual in improving the dialectical powers of the student, and helping him to the discovery and explanation of the essential properties of things!" "Praise or blame, founded on any other consideration, we may dismiss with contempt."

This passage, the importance of which for the appreciation of these two dialogues it is superfluous to point out, derives unexpected illustration from an amusing fragment of a contemporary comic poet, preserved by Athenæus². In this passage we are introduced into the interior of the Academic halls, and the curtain rises upon a group of youths who are "improving their dialectical powers" by a lesson in botanical classification. The subject proposed is not a Sophist, but a pumpkin, and the problem they have to solve is, to what genus that natural production is to be referred. Is a pumpkin a herb? Is it a grass? Is it a tree? The young gentlemen are divided in opinion—each genus having its supporters. Their enquiries, however, are rudely interrupted by a "physician from Sicily," who happened to be present, and who displays his contempt for their proceedings in a manner more expressive than delicate. "They must have been furious at this," says the second speaker. "Oh!" says the other, "the lads thought nothing of it: and Plato, who was looking on, quite unruffled, mildly bade them resume their task of defining the pumpkin and its genus. So they set to work dividing."

In this transaction it is possible that the Sicilian physician may have been in the right, and the philosopher and his pupils in the wrong. And probably the result of their researches, could it be recovered, would add little or nothing to our knowledge of pumpkins. But one thing the passage proves; and that one thing is enough for my purpose. The *διαιρητικοί λόγοι* of the *Sophista* and *Politicus* represent what really occurred within the walls of the

¹ ὡς βραχύτερα ἐν γενομένα τοῖς σὺννοτας ἀπειργάζετο διαλεκτικωτέρους καὶ τῆς τῶν ὄντων λόγῳ δηλώσεως εὐρητικωτέρους. *Polit.* 286 E.

² II. p. 59. As this fragment has not yet received the attention it deserves, it is printed in full.

A. Τί Πλάτων
καὶ Σπεύσιππος καὶ Μενέδημος,
πρὸς τίσι νυκτὶ διατρίβουσιν;
ποία φροντίς, ποῖος δὲ λόγος
διερευνᾶται παρὰ τοῖσιν;
τάδε μοι πινυτῶς, εἴ τι κατειδώς
ἤκεις, λέξον, πρὸς γὰς * * *

B. ἀλλ' οἶδα λέγειν περὶ τῶνδε σαφῶς
Παναθηναίους γὰρ ἰδὼν ἀγέλην
μειρακίων * * *
ἐν γυμνασίοις Ἀκαδημίας
ἤκουσα λόγων ἀφάτων ἀτόπων·
περὶ γὰρ φύσεως ἀφοριζόμενοι
διεχώριζον ζῶων τε βίου
δένδρων τε φύσιν λαχάνων τε γένη.
καὶ τ' ἐν τούτοις τὴν κολοκύντην
ἐξήταζον τίνος ἐστὶ γένους.

A. καὶ τί ποτ' ἄρ' ὠρίσαντο καὶ τίνος γένους
εἶναι τὸ φυτόν; δῆλωσον, εἰ κάποισθ' αὖτις.

B. πρῶτιστα μὲν οὖν πάντες ἀναυδαῖς
τότ' ἐπέστησαν, καὶ κύψαντες
χρόνου οὐκ ὀλίγον διεφρόντιζον.
καὶ τ' ἐξαιφνης ἐτι κυπτόντων
καὶ ζητούντων τῶν μειρακίων
λάχανόν τις ἔφη στρογγύλον εἶναι,
ποῖαν δ' ἄλλος, δένδρον δ' ἕτερος.
ταῦτα δ' ἀκούων ἰατρός τις
Σικελᾶς ἀπὸ γᾶς κατέπαρδ' αὐτῶν
ὡς ληρούντων.

A. ἦ που δευῶς ὠρίσθησαν
χλευάζεσθαι τ' ἐβόησαν·
τὸ γὰρ ἐν λέσγαις ταῖσδε τοιαυτὴ
ποιεῖν ἀκρεπές.

B. οὐδ' ἐμέλησεν τοῖς μειρακίοις·
ὁ Πλάτων δὲ παρών καὶ μάλα πρᾶως,
οὐδὲν ὀρυθθεῖς, ἐπέταξ' αὐτοῖς
πάλιν [ἐξ ἀρχῆς τὴν κολοκύντην]
ἀφορίζεσθαι τίνος ἐστὶ γένους·
οἱ δὲ διήρουν.

Com. Græc. Fragm. v. III. p. 370, ed. Meineke.

Academy: and we can have no doubt that Plato regarded such long-drawn chains of distinctions in the light of a useful exercise for his pupils. They became "more inventive" and "more dialectical"—may we not say, clearer-headed—by the process.

I may add that the Invention of the Divisive Method is traditionally attributed to Plato by the Greek historians of philosophy. Aristotle devotes several chapters of his *Posterior Analytics* to the discussion of this method: he points out its uses and abuses, and defends it against the cavils of Plato's successor Speusippus, who abandoned the method because, as he alleged, it supposed universal knowledge on the part of the person employing it. The method discussed is that which we have been considering, for Aristotle describes it as Division by contradictory Differentiæ¹. He also replies to the objection that this process is not demonstrative—that it proves nothing—by the remark that the same objection applies to the counter process of collection or induction. This defence, I presume, would not in the present day be accepted as satisfactory; for, as the able translator of the *Analytics* observes, "This is the chief flaw in Aristotle's Logic: for some more vigorous method than the Dialectical, the method of Opinion, ought to be employed in establishing scientific principles." To shew the superiority of modern over ancient methods of arriving at truth, is a gratifying, if it is not the most profitable employment of the Historian of Ancient Philosophy. At the same time, I must confess my inability to discover the flaw in the principle of dichotomy, as a principle of classification, in cases where the properties of the objects to be classified are supposed to have been ascertained. A Class can exist as such only by exclusion of alien particulars. The Linnean Class Mammalia for instance, implies a dichotomy of Animals into Mammal and Non-Mammal—into those which give suck and those which do not. The distinction may or may not be a natural or convenient one, but in any other which may be substituted, some "differentia," some property or combination of properties must be fixed upon, which one set of species or individuals possesses, and which all others want. And this is all that is essential in "dichotomy," or the "method of Division by contraries²." The application of the method will,

¹ *Anal. Post. II. c. XIII. § 6*, and *Schol. in loc.* So Abelard (*Ouvrages Inédits. Op. 569*, ed. Cousin: coll. pp. 451, 461), distinguishes between those divisions which imply dichotomy and those which do not: e.g.



Porphyry attributes the latter or dichotomous method to Plato. It could not be "Eleatic," for each of the contraries would be in that scheme a "non-ens." It is remarkable that a similar *Divisio Divisionum* occurs in the *Politicus*, p. 287, § 27, where in lieu of the regular dichotomy a rougher form of classification is for once adopted. This Plato, keeping up the original metaphor in the *Phædrus*, describes as a *μελοτομία*. Κατὰ μέλη τοίνυν αὐτάς οἷον ἱερεῖον διαίρωμεθα, ἐπειδὴ δίχα ἀδυνατούμεν, δεῖ γάρ εἰς τὸν ἐγγύτατα ὅτι μάλιστα τέμνειν ἀριθμὸν ἀέλ. The division he proceeds to make, is a distribution of "accessory arts" *συναρτίοι τέχναι*, into seven co-ordinate groups. A similar relaxation is permitted in the *Philebus*, p. 16 D: Δεῖ οὖν ἡμᾶς.....ἀέλ μίαν ἰδέαν περι

παντὸς ἐκάστοτε θεμένουσ ζητεῖν...ἐὰν οὖν [μετα]λάβωμεν, μετὰ μίαν δύο, εἴ πως εἰσὶ, σκοπεῖν, εἰ δὲ μή, τρεῖς ἢ τιν' ἄλλον ἀριθμὸν, καὶ τῶν ἐν ἐκείνων ἕκαστον πάλιν ὡσαύτως μέχρι περ ἂν τὸ κατ' ἀρχὰς ἐν μὴ ὅτι ἐν καὶ ἀπειρά ἐστὶ μόνον ἰδῆ τις, ἀλλὰ καὶ ὄψουσα. I understand this passage as conveying Plato's distinction between his own method and that of the Eleatics and their Eristic successors, who acknowledged only a *ἐν* and an *ἀπειρον*.

² For the length of the process will evidently depend on the distance, so to speak, between the Species generalissima and the Species specialissima, between the remote and the proximate class in the tabulation of species. The very brief dichotomy in the *Gorgias*, p. 464, is evidently the same in principle as the long-drawn divisions in the *Sophista*, as will be seen from the following scheme:

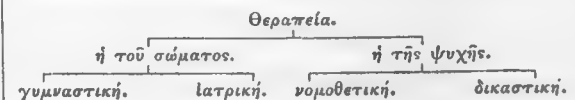

as Plato acknowledges, be more or less successful in proportion to the insight and knowledge of the person employing it. The specimens with which he favours us in these dialogues may be arbitrary, injudicious, or even grotesque: but as logical exercises they are regular—and logic looks to regularity of form rather than to truth of matter, which must be ascertained by other faculties than the discursive. And even in judging of these particular divisions, we must bear in mind the object in view. In the *Sophista* it is Plato's professed intention to distinguish the Sophist from the Philosopher, the trader in knowledge from its disinterested seeker: surely no unimportant distinction, nor one without its counterpart in reality, either in Plato's day or in our own. The ludicrous minuteness with which the successive genera and sub-genera of the "acquisitive class" are made out in detail, would not sound so strange to ears accustomed to the exercises of the Schools; while it subserves a purpose which the philosophic satirist takes no pains to conceal, that, namely, of lowering in the estimation of his readers classes or sects for which he harboured a not wholly unjust or unfounded dislike and contempt. It serves, at the same time, to heighten by contrast the dignity and importance of the philosophic vocation, and in either point of view must be regarded as a legitimate artifice of controversy in a dialogue unmistakably polemical.

APPENDIX I.

IN the foregoing discussions it is assumed that the method of Division sketched in the *Phædrus* is the same with the Dichotomy or Mesotomy of which examples are furnished in the *Sophista* and *Politicus*. This I had never doubted, until the Master of Trinity gave me the opportunity of reading his remarks on the subject, in which a contrary opinion is expressed. I have therefore arranged in parallel columns the description of the process of Division, as given in the *Phædrus*, and in the two disputed dialogues; from which it will appear that the *onus probandi*, at any rate, lies with those who deny that the processes meant are the same. I must premise that the Master of Trinity's question, "If this," viz. the method in the *Sophista*, "be Plato's Dialectic, how came he to omit to say so there?" has been already answered by anticipation in p. 16, note 1, but more fully in *Soph.* 235, quoted presently.

Where it is implied that all "tendance" is either corporal or mental; that all tendance of the body is comprised in the "antistrophic arts" of the gymnast and the physician, and all tendance of the soul in those of the legislator and the judge. There is, therefore, no room under either for the four pretended arts of the sophist, the rhetorician, the decorator of the person, and the cuisinier. In *Politicus*, 302 E, the dichotomy is comprised in a single step: ἐν ταύταις δὲ τὸ παράνομον καὶ ἔνομον ἐκάστην διχοτομεῖ τούτων.

I trust I shall not be understood as consciously advancing

opinions contrary to those of the Master of Trinity on the subject of Classification. But so far as I comprehend his views they do not seem necessarily inconsistent with my own. The typical principle of Classification seems, in its spirit at least, strikingly Platonic; but it surely involves physical or metaphysical ideas which transcend the limits of formal Dialectic. Be this as it may, I should be sorry to have it supposed that I conceive my opinion on such a subject to be of any value in comparison with that of the historian of *Inductive Science*. This would be to "lecture Hannibal on the Art of War."

Phædrus, 265 ε, § 110.

ΦΑΙ. Τὸ δ' ἕτερον δὴ εἶδος τί λέγεις ὦ Σώκρατες;

ΣΩ. Τὸ πάλιν κατ' εἶδη δύνασθαι τέμνειν, κατ' ἄρθρα, ἢ πέφυκε, καὶ μὴ ἐπιχειρεῖν καταγύναι μέρος μηδέν, κακοῦ μαγείρου τρόπῳ χρώμενον· ἀλλ' ὥσπερ ἄρτι πῶ λόγῳ τὸ μὲν ἄφρον τῆς διανοίας ἐν τι κοινῇ εἶδος ἐλαβέτην, ὥσπερ δὲ σώματος ἐξ ἐνός διπλῶ καὶ ὁμώνυμα πέφυκε, σκαιά, τὰ δὲ δεξιὰ κληθέντα, οὕτω καὶ τὸ τῆς παρανοίας ὡς ἐν ἡμῖν πεφυκὸς εἶδος ἠγασμένῳ πῶ λόγῳ, ὁ μὲν τὸ ἐπ' ἀριστέρα τερμνόμενος μέρος, πάλιν τοῦτο τέμνων οὐκ ἐπανῆκε, πρὶν ἐν αὐτοῖς ἐφευρῶν ὀνομαζόμενον σκαιόν τιν' ἔρωτα ἐλοιδόρησε μάλ' ἐν δίκῃ. ὁ δ' εἰς τὰ ἐν δεξιᾷ τῆς μανίας ἀγαθῶν ἡμᾶς, ὁμώνυμον μὲν ἐκείνῳ θεῖον δ' αὖ τιν' ἔρωτα ἐφευρῶν καὶ προτεινόμενος ἐπήνεσεν ὡς μέγιστον αἴτιον ἡμῖν ἀγαθῶν.

ΦΑΙ. Ἀληθέστατα λέγεις.

ΣΩ. Τούτων δὴ ἔγωγε αὐτός τε ἐραστής, ὦ Φαῖδρε, τῶν διαιρέσεων καὶ συναγωγῶν, ἵν' οἷός τ' ὦ λέγειν τε καὶ φρονεῖν· εἴαν τέ τιν' ἄλλον ἠγῆσωμαι δύνατον εἰς ἐν καὶ ἐπὶ πολλὰ πεφυκὸθ' ὄραν, τοῦτον διώκω “κατόπισθε μετ' ἴχνιον ὥστε θεοῖο.” Καὶ μέντοι καὶ τοὺς δυναμένους αὐτὸ δρᾶν εἰ μὲν ὀρθῶς ἢ μὴ προσαγορεύω θεὸς οἶδε, καλῶ δ' οὖν μέχρι τοῦδε διαλεκτικούς.

Sophista, 264 ε.

ΞΕ. Πάλιν τοῖνον ἐπιχειρῶμεν, σχίζοντες διχῆ τὸ προτεθὲν γένος, πορεύεσθαι κατὰ τοῦπὶ δεξιὰ αἰεὶ μέρος τοῦ τμηθέντος ἐχόμενοι τῆς τοῦ σοφιστοῦ κοινωνίας, ἕως ἂν αὐτοῦ τὰ κοινὰ παντὰ περιελόντες, τὴν οἰκίαν λιπόντες φύσιν ἐπιδείξωμεν μάλιστα μὲν ἡμῖν αὐτοῖς, ἔπειτα δὲ καὶ τοῖς ἐγγυτάτῳ γένει τῆς τοιαύτης μεθόδου πεφυκόσιν.

Ib. 253 D, § 82. Τὸ κατὰ γένη διαριεῖσθαι, καὶ μήτε ταῦτὸν εἶδος ἕτερον ἠγῆσασθαι μήθ' ἕτερον ὄν ταῦτὸν μῶν οὐ τῆς διαλεκτικῆς φήσομεν ἐπιστήμης εἶναι; Θ. [Ναί.] φήσομεν... Ξ. ἀλλὰ μὴν τό γε διαλεκτικὸν οὐκ ἄλλῃ δώσεις, ὡς ἐγγῆμαι, πλὴν τῷ καθαρῶς τε καὶ δικαίως φιλοσόφῳ.

Ib. 229 B, § 31. Τὴν ἄνοιαν ἰδόντες εἴ πῃ κατὰ μέσον αὐτῆς τομῆν ἔχει τινά. διπλῆ γὰρ αὐτῇ γιγνομένη δῆλον ὅτι καὶ τὴν διδασκαλικὴν δύο ἀναγκάζει μόρια ἔχειν, ἐν ἐφ' ἐνὶ γένει τῶν αὐτῆς ἐκατέρῳ.

Politicus, 263 B. Εἶδος μὲν ὅταν ἢ του, καὶ μέρος αὐτὸ ἀναγκαῖον εἶναι τοῦ πράγματος ὅτου περ ἂν εἶδος λέγηται· μέρος δὲ εἶδος οὐδεμία ἀνάγκη. (This explains the κατ' ἄρθρα ἢ πέφυκε of the *Phædrus*.)

Ib. 265 A. Καὶ μὴν ἐφ' ὃ γε μέρος ὄρμηκεν ὁ λόγος ἐπ' ἐκεῖνο δυο τινὲ καθορᾶν ὁδῶ τεταμένα φαίνεται, τὴν μὲν θάπτω, πρὸς μέγα μέρος σμικρὸν διαιρούμενον, τὴν δ' ὅπερ ἐν τῷ πρόσθεν ἐλέγομεν, ὅτι δεῖ μεσοτομεῖν ὅτι μάλιστα, τοῦτ' ἔχουσαν μᾶλλον, μακροτέραν γε μὴν.

Ib. 262 D, occurs a specimen of the “unskilful carving” (κακοῦ μαγείρου τρόπου) of the *Phædrus*. Εἴ τις τάνθρώπινον ἐπιχειρήσας δίχα διελέσθαι γένος διαιροίη καθάπερ οἱ πολλοί... τὸ μὲν Ἑλληνικὸν (τὸ δὲ) βάρβαρον... ἢ τὸν ἀριθμὸν τις αὖ νομίζει κατ' εἶδη δύο διαιρεῖν μυριάδα ἀποτεμνόμενος ἀπὸ πάντων, ὡς ἐν εἶδος ἀποχωρίζων, κ.τ.λ.

In allusion to *Xen. Mem.* iv. § 11, a passage noticed by the Master of Trinity, p. 595 of his paper, I may observe that the etymology of Dialectic, ἀπὸ τοῦ διαλέγειν, is undoubtedly vicious, and is nowhere countenanced by Plato. On the contrary, Dialectic is described in the *Philebus*, 58 E, as ἡ τοῦ διαλέγεσθαι δύναμις. He could not have adopted Xenophon's etymology, for as we have seen, the Platonic Dialectic includes συναγωγή as well as διαιρέσεις. The etymology was tempting, and Xenophon, who writes very much at random upon philosophical subjects, was unable to resist the temptation. A similar error is that of Hegel, who in his *History of Philosophy*, derives σοφιστής from σοφίζειν instead of σοφίζεσθαι, an error in which he has been followed by English scholars who ought to have known better.

APPENDIX II.

On the Earth-born (γηγενεῖς) of Sophista, 246.

Of the three contemporary sects professing some form of Materialism, I have singled out the Cynic as that which alone answers the conditions of Plato's description. The following extracts from the fragments of Democritus, and from Aristotle's notices of his opinions, seem conclusive against his claim to a share in the Gigantomachy.

1. The sect in question held that, τοῦτο μόνον ἔστιν, ὃ παρέχει προσβολὴν καὶ ἐπαφήν τινα.

2. ταῦτόν σῶμα καὶ οὐσίαν ὠρίζοντο· they defined "substance" to mean corporeal substance only.

3. They despised τοὺς φάσκοντας μὴ σῶμα ἔχον εἶναι.

1. Democritus, on the contrary, says, νόμῳ πάντα τὰ αἰσθητά, ἐτέη ἄτομα καὶ κενόν.—*Frag. ed. Mullach. p. 204.*

2. Democritus denies that the sense of touch conveys any true knowledge. Ἡμεῖς τῷ μὲν εἶντι οὐδὲν ἀτρεκέες ξυνίεμεν, μεταπίπτον δὲ κατὰ τε σώματος διαθιγὴν καὶ τῶν ἐπεισιόντων καὶ τῶν ἀντιστηριζόντων.

3. Democritus held "ὅτι οὐθέν μᾶλλον τὸ ὄν τοῦ μὴ ὄντος ἔστιν, ὅτι οὐδὲ τὸ κενὸν τοῦ σώματος.—*Arist. Met. i. 4.* In other words, that *vacuum* (*his* μὴ ὄν) was in every respect as real as corporeal substance.

The Cyrenaics are not the γηγενεῖς, for they admit nothing to be real except the affection (πάθος), of which we are conscious in the act of sensation, an affection produced by some cause unknown. The *objects* of sense are to them as unreal as they were to Berkeley. *Sext. Empir. adv. Matth. vii. 191*: Φασιν οἱ Κυρηναῖκοι κριτήρια εἶναι τὰ πάθη, καὶ μόνα καταλαμβάνεσθαι καὶ ἀδιαφυστὰ τυγχάνειν· τῶν δὲ πεποιηκότων τὰ πάθη μηδὲν εἶναι καταληπτὸν μηδὲ ἀδιαφυστόν.

The case of the Ephesian ῥέοντες is not worth considering, for they acknowledged no οὐσία, as the Earth-born know nothing of γένεσις, which they properly class with the ἀόρατον.

The view I have adopted, that the passages in the *Theætetus* and *Sophista* both refer to Antisthenes, and that the latter dialogue is in the main a hostile critique of his opinions, occurred to me in the course of my lectures on the *Theætetus* in 1839, as I find from MS. notes in an interleaved copy. I mention this, because Winckelmann in his *Fragments of Antisthenes*, published in 1842, observes in a note: "Omnino in multis dialogis ut in Philebo, Sophista, Euthydemo, Platonem adversus Antisthenem celato tamen nomine certare, res est nondum satis animadversa." Some of the allusions to this philosopher which Winckelmann detects in the *Theætetus* appear to me doubtful, but I observe with pleasure that he acknowledges the double bearing of the epithet ἀντίτυπος, the perception of which first put me on the enquiry of which I have given some of the results in the foregoing paper.

IX. *On the Substitution of Methods founded on Ordinary Geometry for Methods based on the General Doctrine of Proportions, in the Treatment of some Geometrical Problems.* By G. B. AIRY, Esq. *Astronomer Royal.*

[Read Dec. 7, 1857.]

THE doctrine of Proportions, laid down in the Fifth Book of Euclid's *Elements*, is, so far as I know, the only one which is applicable to every case without exception. It is subject only to the condition, that the quantities compared, in each ratio, shall be of the same kind (without requiring generally that the quantities in the different ratios shall be of the same kind); a condition which appears essential to the idea of ratio.

This generality, however, as in other instances, is not without its inconvenience. The methods of demonstration which are applied by Euclid are very cumbrous and exceedingly difficult to retain in the memory, and I know but one instance (that of the proposition *ex æquali in ordine perturbatâ*, as amended by Professor De Morgan) in which it has been found practicable to simplify them. It is therefore natural that attempts should be made, in special applications of the doctrine of proportions, to introduce the facilities which are special to each case.

In the special application in which numbers are the subject of proportion, methods have long since been introduced, departing widely in form from Euclid's, yet demonstrably leading to the same results, and possessing all desirable facility of application.

No attempt, I think, has been made to avoid the necessity for employing Euclid's generalities, when geometrical lines alone are the subject of consideration. Yet there are cases in which these generalities have always been openly or tacitly employed, but in which the nature of the investigation seems to indicate that there is no need to introduce proportions at all. I was led to this train of thought by considering the well-known theorem, "If pairs of tangents be drawn externally to each couple of three unequal circles, the three intersections of the tangents of each pair will be in one straight line." This, I believe, has always been proved by the use of certain propositions of proportion. Yet the theorem starts from data without proportions, and leads to a conclusion without proportions; and it seems wrong that it should be conducted by intermediate steps of proportions, the theorems of which have been proved by methods based fundamentally on considerations of arbitrary equimultiples.

It appeared to me, on examination, that this and similar investigations, of which lines only are the subject, might be put in a simple and satisfactory form, referring to nothing more advanced than the geometry of Euclid's Second Book, by a new treatment of a theorem equivalent to Euclid's simple *ex æquali*, and of the doctrine of similar triangles. I beg leave to

place before the Society the series of propositions which I suggest as sufficient for these purposes, and (as an example) their application to the particular Theorem to which I have alluded. I have omitted several merely formal steps in the demonstrations. It will be seen that the demonstrations which I offer, though applying to the properties of lines only, require the use of areas; but in this respect they are simpler than Euclid's, which, though applying to lines only, require the use both of areas and of the process of equimultiples.

PROPOSITION (A). If the rectangle contained under the sides a, B , be equal to the rectangle contained under the sides b, A ; and if these rectangles be so applied together that the sides a and b shall be in a straight line and that the side B shall meet the side A ; the two rectangles will be the complements of the rectangles on the diameter of a rectangle.

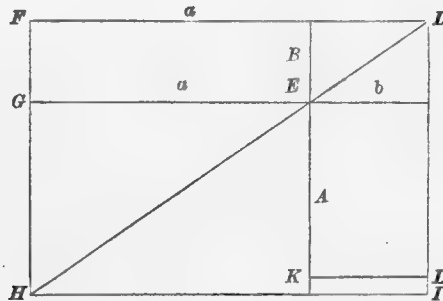

Because the opposite vertical angles of the two rectangles are equal at the point of meeting, A and B will be in the same straight line. Produce the external sides of the rectangles till they meet in D , join DE ; and, as the sum of the angles GFD, EDF , is less than two right angles, produce the lines FG, DE , till they meet in H ; and draw HI parallel to FD or GE . If the rectangle under b and A is not terminated in the line HI , let it be terminated by the line KL . Since KL is parallel to b or GE and therefore parallel to HI , it will be entirely above or below HI . Now by Euclid, the complements FE, EI , are equal; but, by hypothesis, FE, EL , are equal; therefore EL is equal to EI , which is impossible if the line KL is above or below HI ; therefore KL coincides with HI , and the rectangle b, A , coincides with the complement EI , and the two given rectangles therefore are the complements, &c. Q.E.D.

PROPOSITION (B). If the rectangle contained under the lines a, B , is equal to the rectangle contained under the lines A, b ; and if the rectangle contained under the lines b, C , is equal to the rectangle contained under the lines B, c ; then will the rectangle contained under the lines a, C , be equal to the rectangle contained under the lines A, c .

[This is equivalent to the ordinary *ex æquali* theorem,

If $a : b :: A : B$,

and $b : c :: B : C$,

Then will $a : c :: A : C$.]

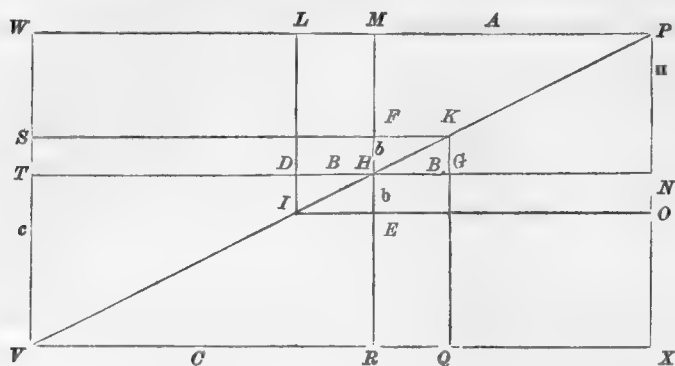

Construct the similar and equal rectangles DE , FG , with sides b and B ; and apply them with their angles meeting at H , in such a manner that the side DH or B of one shall be in the same straight line with HG or B of the other; then will the side FH or b of one be in the same straight line with HE or b of the other. In the right-angled triangles IDH , HFK , the sides including the right angles are equal, therefore the angle FHK is equal to the angle DIH , and is the complement of the angle DHI ; therefore IH and HK are in the same straight line.

To DH apply the rectangle DM whose side DL or HM is equal to a ; the sides DL and HM will be in the same straight lines with DI and HE . To HE apply the rectangle HO , whose side HN or EO is equal to A ; the sides HN and EO will be in the same straight lines with HD and EI . Produce LM , ON , to intersect in P , and join KP .

Then, because the rectangle LH , which is the rectangle contained under a and B , is equal to HO , which is the rectangle contained under b and A ; by Proposition (A), LH and HO are the complements of the parallelograms about the diameter of the rectangle LO ; therefore IH and consequently IHK (which are in the same straight line) are in the diameter; therefore $IHKP$ is a straight line.

In like manner, to HG apply the rectangle HQ whose side GQ or HR is equal to c ; and to HF apply the rectangle HS whose side FS or HT is equal to C ; and produce ST and QR to meet in V ; and join IV . Then, proceeding from the hypothesis that the rectangle contained under c and B is equal to the rectangle contained under b and C , it will be shewn in like manner that $KHIV$ is a straight line.

Therefore $PKHIV$ is one straight line.

Complete the rectangle WX . Then WH , HX , are complements of the parallelograms about the diameter of WX , and are therefore equal. But WH is the rectangle contained under a , C , and HX is the rectangle contained under c , A ; therefore the rectangle contained under the lines a , C , is equal to the rectangle contained under the lines A , c . Q.E.D.

COROLLARY. By repeating the operation, the theorem may be extended to four or any number of terms of comparison of rectangles, following in a similar order.

PROPOSITION (C). If two right-angled triangles are equiangular, and if a , A , are their hypotenuses, and b , B , homonymous sides; the rectangle contained under the lines a , B , is equal to the rectangle contained under the lines A , b .

[The equivalent theorem in proportions is

$$a : b :: A : B.]$$

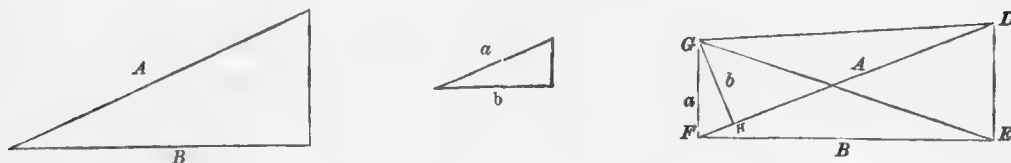

Apply one triangle upon the other as in the right-hand diagram, so that the side b meets the hypotenuse A at right angles, and the vertex of the angle opposite b meets the vertex of the angle included by A and B . Since the angle GFH is equal to the angle FDE , it is the complement of the angle DFE ; and GFE is therefore a right angle; and GF is parallel to DE . Now the rectangle under a and B is the double of the triangle GFE ; and the rectangle under b and A is the double of the triangle GFD . But because GF is parallel to DE , the triangle GFE is equal to the triangle GFD . Therefore the rectangle under a and B is equal to the rectangle under A and b . *Q.E.D.*

PROPOSITION (D). If a, c , and A, C , are homonymous sides of equiangular triangles, the rectangle contained under a, C , will be equal to the rectangle contained under c, A .



From the angles included by the sides A, C , and a, c , let fall the perpendiculars B, b , upon the third side. The corresponding right-angled triangles thus formed are easily shewn to be equiangular. Hence, by Proposition (C),

Rectangle under a, B , is equal to rectangle under A, b .

Again, Rectangle under b, C , is equal to rectangle under B, c .

Therefore by Proposition (B),

Rectangle under a, C , is equal to rectangle under A, c . *Q.E.D.*

PROPOSITION (E). If b, c , and B, C , are homonymous sides including the right angles of two equiangular right-angled triangles, the rectangle contained under b, C , will be equal to the rectangle contained under c, B .

This may be considered a case of the last proposition, or it may be treated independently thus.

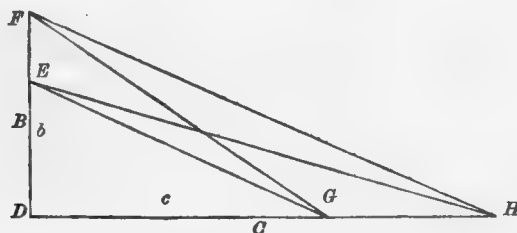

Apply the two triangles together, so that their right angles coincide, and their homonymous sides are in the same straight lines. In consequence of the equality of the remaining angles, the hypotenuses EG, FH , will be parallel. Therefore the triangle FEG is equal to the triangle HEG . To each add the triangle EDG , then the triangle FDG is equal to the triangle EDH . But the rectangle under b, C , is double of the triangle EDH ; and the rectangle under c, B , is double of the triangle FDG . Therefore the rectangle under b, C , is equal to the rectangle under c, B . Q.E.D.

PROPOSITION (F). If the rectangle contained under the lines a, B , is equal to the rectangle contained under the lines A, b ; the parallelogram contained under the lines a, B , will be equal to the equiangular parallelogram contained under the lines A, b .

[This is equivalent to the proposition,

$$\text{If } a : b :: A : B,$$

$$\text{Then } a : b :: A \cos a : B \cos a.]$$

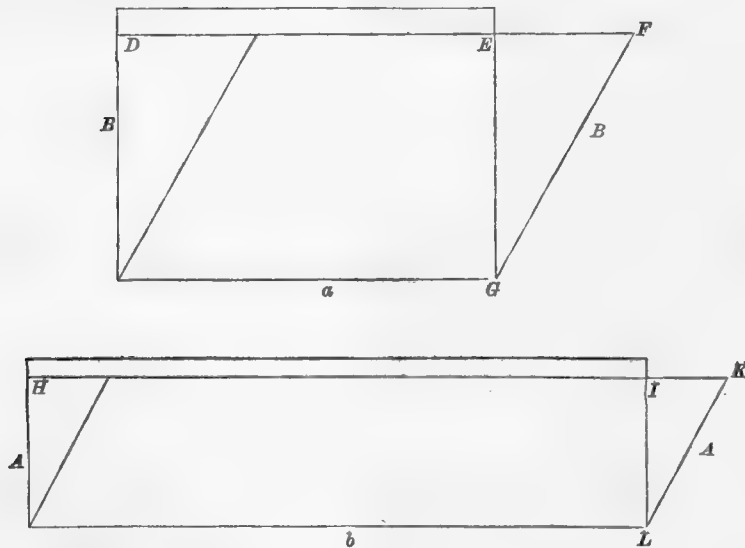

In the figure, produce the upper sides of the parallelograms to cut the vertical sides of the rectangles in D and H . The rectangles DG, HL , are equal to the given parallelograms, therefore it is to be proved that the rectangle DG is equal to the rectangle HL , or that the rectangle under a, EG , is equal to the rectangle under b, IL .

Since the parallelograms are equiangular, the right-angled triangles EGF, ILK , are equiangular; and therefore by Proposition (C), the rectangle under EG, A , is equal to the rectangle under IL, B . But by hypothesis, the rectangle under B, a , is equal to the rectangle under A, b ; therefore by Proposition (B), the rectangle under EG, a , is equal to the rectangle under IL, b . Or, the parallelogram under the lines B, a , is equal to the equiangular parallelogram under the lines A, b . Q.E.D.

These Propositions, I believe, will suffice for treatment of the first thirteen Propositions of Euclid's Sixth Book (Prop. I. excepted), and for all the Theorems and Problems apparently involving proportions of straight lines (not of areas, &c.) which usually present themselves. As an instance of their application, I will take the theorem to which I alluded at the beginning of this paper.

THEOREM. If pairs of tangents are drawn externally to each couple of three unequal circles, the three intersections of the tangents of each pair will be in one straight line.

I shall omit the demonstration that, for each couple of circles, the pair of tangents and the line passing through the two centers all intersect at the same point; and I shall use only the intersection of one tangent with the line passing through the center. Also I shall omit the construction and its demonstration, for inserting between the greatest and least of the three circles a circle equal to the remaining circle, having its center upon the line joining their centers, and being touched by their tangent.

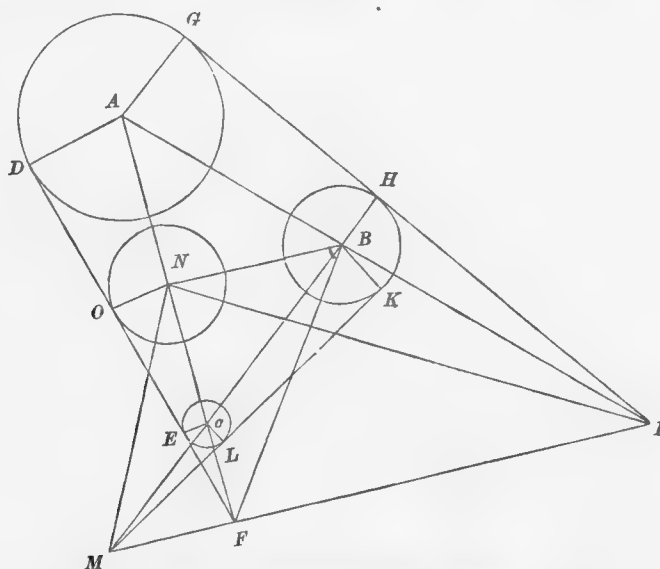

Let A, B, C , be the centers of the given circles. Let N be the center of the circle whose radius NO is equal to the radius BK , and which is touched at O by the tangent DE . Join NB, MF, FI, MN, NI, FB .

First we shall prove that MF is parallel to NB .

The triangles NOF, CEF , have each one right angle, and they have another angle common; hence they are equiangular; and by Proposition (C), the rectangle under CF, NO , is equal to the rectangle under NF, EC ; or, the rectangle under CF, BK , is equal to the rectangle under NF, CL . Again, the triangles BMK, CML , are equiangular, for each has one right angle, and they have another angle common; therefore the rectangle under CL, MB , is equal to the rectangle under BK, MC . Consequently, by Proposition (B), the rectangle under CF, MB , is equal to the rectangle under NF, MC . Therefore, by Proposition (F), the parallelogram under CF, MB , which has one angle equal to MCF , is equal to the parallelogram under NF, MC , which has one angle equal to MCF . But the former of these

parallelograms is double of the triangle BMF , and the latter is double of the triangle MNF . Therefore the triangle BMF is equal to the triangle MNF , and therefore MF is parallel to NB .

Secondly. To prove that FI is parallel to NB .

It will be shewn in exactly the same way that the parallelogram under AF, BI , with the angle FBI , is equal to the parallelogram under AI, NF , with the angle FBI . But the parallelogram under AF, BI , with the angle FBI , is the excess of the parallelogram under AF, AI , with the angle FBI , above the parallelogram under AF, AB , with the same angle; or is the excess of double the triangle AFI above double the triangle AFB , or is double the triangle BFI . Similarly the parallelogram under AI, NF , with the angle FBI , is double the triangle NFI . Therefore the triangles BFI, NFI , are equal; therefore FI is parallel to NB .

And as MF and FI are both parallel to NB , MF and FI are in the same straight line.

Q. E. D.

ADDENDUM.

I AM permitted by Professor De Morgan to transcribe the simple process for demonstrating the theorem of *ex æquali in ordine perturbata*, to which allusion is made above.

$$\text{If } a : b :: B : C,$$

$$\text{and } b : c :: A : B,$$

$$\text{Then will } a : c :: A : C.$$

To exhibit the process more clearly to the eye, use the connecting mark \frown for one ratio and \smile for the other; then the theorem stands thus,

$$\left. \begin{array}{l} \text{If } a \frown b \smile c, \\ \text{and } A \smile B \frown C, \end{array} \right\} \text{ then } a : c :: A : C.$$

To prove it, take a fourth quantity d , such that $a : b :: c : d$.

$$\text{Then } b \smile c \frown d.$$

$$\text{But } A \smile B \frown C.$$

Therefore, *ex æquali*, $b : d :: A : C$.

But, because $a : b :: c : d$, therefore *alternando*, $a : c :: b : d$. Substituting therefore the ratio $a : c$ for $b : d$ in the analogy just found,

$$a : c :: A : C.$$

Q. E. D.

G. B. AIRY.

X. *On the Syllogism, No. III, and on Logic in general.* By AUGUSTUS DE MORGAN, F.R.A.S., of Trinity College, Professor of Mathematics in University College, London.

[Read Feb. 8, 1858.]

I PUT this paper under the title here given, for the sake of continuity of reference: in scope, however, it is more extensive than those which precede (Vol. VIII. Part 3; Vol. IX. Part 1). It will best be disposed under two heads. I shall first put together remarks on the object of logic; on its present state; on the opinion of the world with respect to it; on the views which I take of it, in opposition to the world at large as to its advantages, and to the writers upon it as to its details. I shall incidentally answer some objections to my former paper; objections, not objectors: and I would gladly do something, be it ever so little, to hasten the time when logic shall again be a part of education in the University of Cambridge. I am satisfied that there is no study, however useful, no exercise of the intellect, however essential, but has its own short-comings which can only be made good by the study of mind as mind, psychology; and induces its own bad habits which can only be eradicated by the study and practice of thought as thought, logic. But psychology and logic, in their turn, require other studies even more than other studies require them.

In the second part, I shall present the elementary points of the system which I advocate. Which of the two parts should be taken first is a question which each reader must decide for himself.

SECTION I. *General Considerations.*

I. Eleven years ago, when I began to put together details on which I had been thinking during several previous years, I had not the encouragement which would have arisen from a knowledge of what was then going on in the logical world. In my own mind I was facing Kant's* assertion that logic neither has improved since the time of Aristotle, nor of its own nature can improve, except† in perspicuity, accuracy of expression, and the like. I did not know that very high authority was then teaching its *alumni* to assert that logic had always

* There is an intelligible translation of Kant's logic, and, as I judge by comparison with Tissot, a good one, by John Richardson. London, 1819, 8vo.

† Of Lambert's additions Kant says that like all legitimate subtleties, they *sharpen the intellect*, but are of no material use. Logic thinks about thought: what for? that we may think the better, that we may sharpen the intellect. Conse-

quently, every part of logic which makes us think more acutely conduces to the very use of logic itself. No part of logic is of any *material* use, in Kant's sense of the word. The scaffolding by which the house was built is of no use to the inhabitants, except indeed when repairs or additions are wanted. But the main question of the utility of logic refers to education, during which the scaffolding is up.

been one sided, deprived of much scientific truth, encumbered with much scientific falshood, perverted and erroneous in form, and given, in some of its doctrines, to impeach the truth of the laws of thought on which it is founded. In one extreme of opinion, logic, language, and common sense are never at variance: in another, Aristotle exhibits the truth partially, not always correctly, in complexity, and even in confusion. Between these opinions I am not obliged to choose. I am satisfied, with the satisfaction of one long used to the distinction between demonstrated and probable conclusion, that the old logic is, so far as it goes, accurate in method and true in result; that is, as to the *quod semper, quod ubique, quod ab omnibus*: but without affirming that all that is called necessary is necessary, or that all that is called natural is natural. I feel equally sure that it is only a beginning; that it contains but a small part of the whole which it arrogates to itself in its old aspirations and its modern definition; and that the low estimation in which a large part of the educated world now holds it is to be traced to consequences of this incompleteness.

II. Logic inquires into the form of thought, as separable from and independent of the matter thought on. To every proposal for a new introduction there is but one answer;—You outstep the bounds of logic, you introduce material considerations. On this point the first question is, What is the distinction of form and matter?—the second, Who are best able to judge of it?

The *form* or *law* of thought—asserted differences between these words being of no importance here—is detected when we watch the machine in operation without attending to the matter operated on. The form may again be separable into form of form and matter of form: and even the matter into form of matter and matter of matter; and so on. The *modus operandi* first detected may be one case of a limited or unlimited number, from all of which can be extracted one common and higher principle, by separation from details which are still differences of form.

Take a nut-cracker, two levers on a common hinge. Put a bit of wood between the levers to represent filberd, walnut, beechnut, almond, or any other kind of nut. We have here what a logician would call the *form of nut-cracking*: and, imitating his practice of insisting that he has obtained pure form so soon as he has effected one separation, we may say that we have got the *pure form* of nut-cracking. But when we come to consider the screw, the hammer, the teeth, &c. we begin to apprehend that the pure form of nut-cracking is strong pressure applied to opposite sides of the nut, no matter how; and this even though we may detect in all the instruments the *principle*, as we call it, of the hinged levers.

The logician is not much accustomed to the working presence of his own great distinction: the mathematician deals with it unceasingly, though with little apprehension of its existence, in most cases. Though logic has been in waking life for at least fifteen hundred years, its real definition has not been in recognised existence during the fifteenth part of that time: this definition has indeed been obeyed in many points, it has been caught for a minute and let go again, it has been seen through a glass darkly,—at any time from Aristotle inclusive: it is only in very modern days that it has been seized, stript of its coverings, and firmly fixed in its place. And the first imperfect introduction, and the perfect recognition, have been the work of mathematicians.

Of the two philosophers who might have made the distinction of form and matter exercise a strong influence over their systems, Aristotle did it, and Plato did not. Plato's writings do not convince any mathematician that their author was strongly addicted to geometry; they shew at most that he may have been well versed in it: I have no objection to say that geometry helped him in his colouring. We know that he encouraged mathematics, that his followers form a school, and that the reputation of the school has given the character of a geometer to the founder. But if—which nobody believes—the *μηδεις ἀγεωμέτρητος εἰσίστω* of Tzetzes had been written over his gate, it would no more have indicated the geometry within than a warning not to forget to bring a packet of sandwiches would now give promise of a good dinner. But Aristotle was a mathematician, versed in that science and addicted to it: geometry aided him in the tracing of his outline. This appears throughout his writings, even after rejection of those which are doubtful, some of which, supposing him to be only a putative father, show that a very positive mathematical character was assigned to him by his successors. To him we owe such perpetual indication of the distinction of form and matter that many, including some who should have known better, have assigned the *form of thought* to him as his definition of *logic*, giving him the word into the bargain. But the definition was never distinctly conceived in that character until the last century, when it was propounded by a philosopher whose earliest studies had been in mathematics, which he had taught in conjunction with logic for fifteen years before he gave himself up to the study of the pure reason. If, between Kant* and Aristotle, there were one leader of philosophical opinion who more nearly than another caught the conception, it was the mathematician Leibnitz. And the history of man in species analogises with what we have seen of man in individuals: we trace our mathematics to the Greeks and the Hindoos, the two independent cultivators of systems of logic in which form is investigated for its own sake, though the separation is indistinctly conceived by both. Of the Romans, we only know that they originated nothing, either in mathematics or in logic: and it is just worth notice here that Boethius, the only Roman who gave us a summary of Aristotle, was the only Roman who gave us a summary of Euclid.

The separation of mathematics and logic which has gradually arrived in modern times has been accompanied, as separations between near relations generally are, with a good deal of adverse feeling. Great names in each have written† and spoken contemptuously of the other; while those who have attended to both are aware that they have a joint as well as a separate value. This alienation of the two sciences has furnished two magazines to those who would put down all education except that which immediately conduces to production of wealth: in

* It is only of late years that, in this country at least, Kant's definition has been clearly apprehended, and its truth sincerely felt. If the inquirer will look out for English works preceding 1848, or thereabouts, which state Kant's definition as an existing thing, not to speak of adopting it, he will have some difficulty in finding one. In some old notes of my own, made after comparison of Aristotle, some of the mediævals, and Kant, I find the following sentence: "I should say [of formal and material] that the great leader *saw* the distinction, that the schoolmen *made* the distinction, and that Kant *built upon* the

distinction."

† There is no occasion to refer to any of the ordinary exhibitions, whether dissertations in favour of ignorance, or orations in contempt of knowledge. But there is one which deserves preservation for its humour, and which may be lost with an ephemeral pamphlet, if not elsewhere recorded. An Oxford M.A. writing on education, about ten years ago, advocated some pursuit of mathematics: for, said he, man is an arithmetical, geometrical, and mechanical animal, as well as a rational soul.

fact, if what either party has advanced against the other be true, the common opponent has a good case against both, provided only mathematics enough for a higher kind of land-surveyor be exempted from the common doom, and made a part of professional education.

There never was in history the time at which mathematics, in any branch, wanted a palpable separation of form and matter: and mathematicians have always seen the separation, though they have not always rightly apprehended the relation of the components. They have spoken much of *abstraction*, a word truly applied to their function: but they have not duly distinguished between abstraction of colleague qualities from each other, and abstraction of the instrument from the material. They have also dwelt much on *generalisation*, a word so truly descriptive of what is always taking place within the precinct, that they have oftentimes made it give name to the fence.

The first element of mathematical process is the separation of space from matter filling it, and quantity from the material *quantum*: whence spring geometry and arithmetic, the studies of the laws of space and number. Distinctions which are of form in arithmetic become material in algebra. The lower forms of algebra become material in the algebra of the functional symbol. The functional form becomes material in the differential calculus, most visibly when this last is merged in the calculus of operations. But, though the distinction of form and matter be very certainly present to those who can see it, it is equally certain that many followers of the mathematics have their ideas of the distinction as dark as those of any of the old logicians. The difference is that the mathematician cannot help dealing with the thing in question, though under a name of too little intension: he cannot but be sensible of *abstraction*; but he may be unused to remember that he abstracts *form* from *matter*. The logician on the other hand may, as often was the case, have his system cast in so material a mould, that he is hardly sensible even of abstraction: and when the fault is not palpably committed in the treatise, the individual reader may, of his own inaptitude to abstract except under symbolic compulsion, convert formal logic into material. Accordingly, the separation of form is often learned language to the logical student, with a bad dictionary to read it by: to the mathematician it is as often M. Jourdain's prose, and nothing more. To the logician it is a collect for certain holidays; it is the paternoster of the mathematician, who may run it over without thinking of the meaning, if he ever knew it. And these tendencies, large in amount in the learner, have their sway even in the books he learns from, and in the discussions of the highly informed: the great distinction of form and matter is more in the theory* of the logician than in his practice, more in the practice of the mathematician than in his theory.

* I am fully aware of the boldness of my comparison of the logician and mathematician, and of the audacious appearance which it is likely to present to a class of inquirers who have hitherto been allowed to distribute functions to the branches of human knowledge pretty nearly in their own way. My averments are of that kind which nothing but success will justify: and about which controversy is useless. It is not competent to those who are only logicians, and to those who are only mathematicians, to settle a question in which the alleged unfitness of either to decide is a part of the matter to be decided: still less is it competent to the few who unite both characters to

demand of the others that they shall see this. Time must settle it; and I believe this will be the way. As joint attention to logic and mathematics increases, a logic will grow up among the mathematicians, distinguished from the logic of the logicians by having the mathematical element properly subordinated to the rest. This *mathematical logic*—so called *quasi lucus a non nimis lucendo*—will commend itself to the educated world by showing an actual representation of their form of thought—a representation the truth of which they recognise—instead of a mutilated and onesided fragment, founded upon canons of which they neither feel the force nor see the utility.

III. Logic bears on its modern banner, The form of thought, the whole form, and nothing but the form. It has been excellently well said that whatever is operative in thought must be taken into account, and consequently be overtly expressible, in logic: for logic must be, as to be it professes, an unexclusive reflex of thought, and not merely an arbitrary selection,—a series of elegant extracts,—out of the forms of thinking. Whether the form that it exhibits be stronger or weaker, be more or less frequently applied, that, as a material and contingent consideration, is beyond its purview. Nevertheless, so soon as a form of thought is exhibited which does not come within the arbitrary selection, the series of elegant extracts, it is forthwith pronounced material:—

St. Aristotle! what wild notions!

Serve a *ne exeat regno* on him!

The proper reply to every accusation of introducing the material where all should be formal, is as follows. You say this thought or process is material: now every material thinking has its form: therefore this thought has its form. Logic is to consider the whole form of thought: *your* logic either contains the form of this thought, or it does not. If it contain* the form of this thought, shew it: if not, introduce it. I shall now state three instances of the objection.

In my last paper, as in my work on *Formal Logic*, I separated form from matter in the copula of the common syllogism. The copula performs certain functions; it is competent to those functions; it is competent because it has certain properties, which are sufficient to validate its use, and, all cases considered, not more than sufficient. The word '*is*,' which identifies, does not do its work because it identifies, except† in so far as identification is a *transitive* and *convertible* notion: '*A is that which is B*' means '*A is B*'; and '*A is B*' means '*B is A*'. Hence every transitive and convertible relation is as fit to validate the syllogism as the copula '*is*,' and by the same proof in each case. Some forms are valid when the relation is only transitive and not convertible; as in '*give*.' Thus if X—Y represent X and Y connected by a transitive copula, *Camestres* in the second figure is valid, as in

Every Z—Y, No X—Y, therefore No X—Z.

* When I see a chapter in a book of logic headed *On material and formal consequence*, distinguishing "*A = B, B = C, therefore A = C*" as *material* from "*A is B, B is C, therefore A is C*" as *formal*, I am at first inclined to think that the distinction of formal and material is that of contained and not contained—in Aristotle. But when the title-page shews me an author whose mind is as free from the sway of that distinction as my own, I am compelled to have recourse to the difference between the ideas of form belonging to the mathematician and to the logician. Is there any *consequence* without *form*? Is not *consequence* an action of the machinery? Is not logic the science of the action of this machinery? Consequence is always an *act* of the mind: on every consequence logic ought to ask, What kind of act? what is the *act*, as distinguished from the *acted on*, and from any inessential concomitants of the action? For these are of the form, as distinguished from the matter. What is the difference of the two syllogisms above? In the first case the mind acts through its sense of the transitivity of '*equals*:' in the second, through its sense of the transitivity of '*is*.' Transitivity is the common form: the

difference between *equality* and *identity* is the difference of matter. But the logician who hugs identity for its transitivity, cannot hug transitivity: let him learn abstraction.

† I again call the reader's attention to the pure form of nut-cracking, with which I began. The syllogism is the nut to be cracked. I believe I have got to the pure form, which equally applies to two levers, a screw forced into a receptacle, Nasmyth's steam-hammer, the collision of a couple of planets, as the case may be: the common form of all being pressure enough applied to opposite sides of the nut. The logician insists upon it that the pure form is a couple of metallic levers, with friction-studs, if that be the proper name, to prevent the nut from slipping aside, and such a hinge that, according to the way we turn it, the levers give convenient entrance to a common nut or a walnut. All his additions to the pure form I admit to be usual and convenient: but I affirm and maintain that whatever can crack a nut, and does crack a nut, is a nut-cracker; and being a nut-cracker, must be considered as a nut-cracker, and included among nut-crackers, in every treatise on the whole form of nut-cracking.

For if any one $X-Z$, this with $Z-Y$, gives $X-Y$, which is excluded by the second premise.

To this the objection is that the process is material, for that it is of the matter of the proposition whether *give* will or will not do: that *touch*, for instance, will not do. Does not this,—from a living writer who in combination of logical learning and logical acumen is second to none—corroborate my assertion that the logician has the distinction of form and matter' more in his theory than in his practice? I might as well say that 'Every X is Y ' is a material proposition: it is of the matter of X and Y whether it be true or no. In the following chain of propositions, there is exclusion of matter, form being preserved, at every step:—

Hypothesis.		
(Positively true)	Every man is animal	
—————	Every man is Y	Y has existence
—————	Every X is Y	X has existence
—————	Every $X - Y$	———— is a <i>transitive</i> relation
—————	α of $X - Y$	α a fraction $<$ or $= 1$.
(Probability β)	α of $X - Y$	β a fraction $<$ or $= 1$.

The last is *nearly* the purely formal judgment, with not a single material point about it, except the transitiveness of the copula. But '*is*' is more intense than the symbol —, which means only transitive copula: for '*is*' has transitiveness, and more. Strike out the word *transitive*, and the last line shews the pure form of the judgment.

The same objection has been raised to the law of inference when the middle term is definitely quantified. If the fractions α and β of the Y s be severally A s and B s, and if $\alpha + \beta$ be greater than unity, it follows that some A s are B s. To this it is objected that whether $\alpha + \beta$ be or be not greater than unity, is material. No doubt it is; and so is the case of the logician's canon of syllogism, that the middle term must be universal in one or both premises. The logician demands $\alpha = 1$, or $\beta = 1$, or both: he can then infer; but only because he knows that when more in number have been named than there are separate things to name, some must have been named twice. But he does not know this better of $1 + \beta$ than of $\frac{2}{7} +$ (more than $\frac{5}{7}$): or if he did, the difference of form and matter is not merely difference of arithmetical facility. The writer against whom I am contending declares that, as a logician, he cannot know that 2 and 2 make 4. I do not ask him for so much: I do not ask him to know that there *are* cases in which $\alpha + \beta > 1$. What I say is this, that in every case in which it shall happen (if ever it do happen, which is by hypothesis more than we know) that $\alpha + \beta > 1$, in each of these cases he is bound, as a logician, to infer that some A s are B s. And this instance is another corroboration of my assertion that the distinction of form and matter is more in the theory of the logician than in his practice.

As a third instance, I note that the limited universe, and its division into two contraries, are pronounced material, because it *is not by logic* we learn that when *property* is the universe, *real* and *personal* are contraries. Neither by logic do we learn that every man is animal; but by logic we analyse our use of this proposition in conversion, in inference &c. Similarly, by logic we learn how we use contraries in inference &c. But what things *are* contraries, logic no more needs to inquire than law needed to inquire who wore the crown

before she settled whether writs should run in the name of the King *de facto* or of the Pretender.

A little consideration will shew us that every inference which is anything more than pure symbolic representation of inference is due to the presence of something material: even a derived or compound symbol, *representing* inference, shews the presence of something material. Here are two purely formal propositions, in which P, Q, R, S, represent individual objects of thought, and -A- indicates a relation A:—

$$P -A- Q \qquad R -B- S$$

P stands in A-relation to Q and R in B-relation to S. What are we to infer? Now rub out R, and for it write Q. This is *material*: it is now seen to be of the matter of our system that the second subject is the first predicate. And now we have P -A- Q, and Q -B- S. Can we infer anything? With the form of combination of relations in our thoughts, we may symbolise it, and say P -AB- S. Now make the relations material: let -A- and -B- each be 'is:' then we have a material inference; P is Q, Q is S, therefore P is S. In common logic, the objects of inference, being terms expressed in general symbols, are void of matter; the relations between them, and the modes of inference, are material: I speak of logic as it is. Many relations have a common form: the logician cannot yet see that when many cases, no matter what, proceed upon a common principle, his concern is with that principle. It is his business to apprehend the principle and to shew, as to the *modus operandi* of the mind, how containing cases severally contain it, and apply it.

I am charged with maintaining that thought is a branch of algebra, instead of algebra a branch of thought. The answer is easy enough. Logic considers, not *thought*, but the *form* of thought, the law of action of its machinery. Psychology herself does not know what thought *is*: and the odds are that if she did she would not feel bound to tell logic. Thought, the genus, has parts of its machinery, usually under cover, which work by daylight in algebra, the species, to every one who has meditated on the principles of algebra. He who makes me confound all other thought with algebra, because I call attention to what is more visible in algebra than in other thought, though it exists in all thought, must make his own logic responsible for the inference, not mine. He may hire a soldier to cook his victuals, because both soldier and cook cut flesh with steel: but neither Mr Boole, the greater culprit, nor I, the lesser* one, have done anything to deserve an invitation to the feast.

I might with much more justice charge the logician with affirming all thought a branch of geometry, instead of geometry a branch of thought. By processes nearly resembling those which led Des Cartes to affirm that space is *all* the essence of matter, he reduces all thought of comparison to the assertion or denial of containing and contained. These are originally terms of space-relation: and his only syllogism, his universal includent of all argument, can be fully symbolised by areas: a practice which many logicians dislike, and with reason, for it tells tales. I have pointed out, in my second paper, the syllogism in which the copulæ may be any relations whatever. The copula of cause and effect, of motive and action, of all in which *post hoc* is of the form and *propter hoc* (perhaps) of the matter, will one day be carefully

* Not meant for extenuation: I wish I were the greater one.

considered in a more complete system of logic. The cases in which A, simultaneous with B, is either cause or effect according to the attribute considered, will be duly symbolised. For instance, it is disputed whether men dive for pearls because pearls fetch a high price, or whether pearls fetch a high price because men dive for them: it is one or the other, according to the attribute of the actions held in view. Considered as *volitions*, the diver is *willing* to dive because the lady is *willing* to pay dear for her necklace. As *necessities*, the lady *must* pay dear because the diver *must* dive. The word *because* is the heading of a chapter in the *form* of thought, of which many a complexity is yet unanalysed, simply because it is possible to reduce relation to class, by throwing 'X has A-relation to Y' into the form 'X *is* in the class of objects having A-relation to Y.' Hence, to the world at large, logic is neither the form of their thought, nor the matter, nor the junction of both. The *judgment* of the logician is only *one* of the judgments of mankind.

When a common person says 'Achilles killed Hector,' his objects of thought are the two heroes: his mode of thinking them is in the relation of slayer and slain in time past. The logician demands that he shall think himself to be identifying by the verb '*is*'—either Achilles with the former slayer of Hector, or Hector with the former slain of Achilles, or slaughter with the former action of Achilles on Hector, or time past with the date of that action. All these forms are unquestionably coexistent and coextensive with the relation affirmed: out of any one all the others may be evolved; they are different dichotomies and reintegrations of a coexistence of four things. But neither reintegration represents the manner in which the relation is held in thought. Each dichotomy makes it possible that a contradiction may step in, which the reintegration denies: one of them shews a front to the assertion that *Patroclus* killed Hector, another to the assertion that Achilles was Hector's *defender*, &c. And so it always happens: a person who wants to signify that 'Achilles was the person who killed Hector' will take care, on the principle of not saying one thing when another is meant, to avoid the phrase 'Achilles killed Hector,' or else to supply 'was the person who' by emphasis on *Achilles*: unless it be a person who has been long in the hands of Giant* Maul. In all propositions, existence is predicated of the terms in the fact of predication. When I say X is Y, I do not mean 'if X exist and Y exist, then X is Y:' I mean that X and Y do exist, and that they are the same. Accordingly, when I am told that 'Achilles *is* the former slayer of Hector,' it is as if it could not be disputed that Hector *was* slain, so that the only question remaining is, Who killed him? For the books of logic give no way of denying 'X is Y' except 'X is not Y.' But should I be told 'Achilles killed Hector' I should not receive it in this way, nor should I believe it was so intended. I should receive it as an equally balanced combination of elements, in which the dichotomy is left to myself, to be made according to my own mode of assent or denial, including a right given to me to preserve the existing balance. I see great difference in the *propositum* between 'This house was built by Jack' and 'This is the [or even a] house that Jack built.' Granting it true that either of the logician's forms will give as much

* According to incomparable John Bunyan, this worthy lived at the end of a dark valley and "did use to spoil young pilgrims with sophistry." What was hinted at appears in this, that Mr Greatheart and the giant settle the *questio* before they

begin to fight, and the opponent objects to the respondent, "These be but generals, man, come to particulars." Maul was the most difficult giant to kill of Bunyan's whole troop.

inference as the simple relation, it does not follow that the logician's form *is* the form of thought we actually employ in inference. It is one thing to say, I can shew you by such and such reductions how to demonstrate the only inference these premises will give; and quite another thing to add, Therefore this is the way you infer.

IV. Logic is both science and art: and the art, the *logica utens*, ought to be a preparation for sure and rapid material application. The proposition of the world at large is highly complex: it is loaded with what I shall call *charges*. It has complex terms, conjunctive and disjunctive; it introduces allusions, for reinforcement, for explanation, for justification of its appearance, for colouring and effect. It gives reasons, takes syllogisms into the description of terms, and implies assertions in giving reasons, leaving the assertions to be supplied from their reasons. It is a tapestry, of which the logical form is only the original web. It undergoes conversions in which idiom demands synonymes: but the *logica docens* keeps clear of the whole theory of complex terms by throwing the proposition into disjunctive or dilemmatic forms which the actual form of thought does not recognise. Is the student of logic, generally speaking, prepared *rapidly* to analyse the two following propositions, and to say whether or no they must be identical, if the identity of synonymes be granted?

The suspicion of a nation is easily excited, as well against its more civilised as against its more warlike neighbours; and such suspicion is with difficulty removed.

When we see a nation either backward to suspect its neighbour, or apt to be satisfied by explanations, we may rely upon it that the neighbour is neither the more civilised nor the more warlike of the two.

This, under the symbols I have used and shall use, is the conversion of the form A, B))CD into c, d))ab. The world would have treated logic with more respect, if it had led up to such conversions as the above. But it lands us and leaves us, as to conversion, in 'Some tyrant is cruel' turned into 'Some cruel is tyrant,' or the like: a needful commencement, but a lame and impotent conclusion.

I will now take a syllogism, *one syllogism*, well charged* certainly, but only with charges

* Of all the writers on logic whom I have examined, John Milton is the one who delights in extracting the syllogism from its loading: his instances are almost entirely from the Latin poets, which he probably needed no sight to recall. Milton's logic was published two years before his death. 'Joannis Miltoni, Angli, Artis Logicæ plenior institutio, ad Petri Rami methodum concinnata' (London, Impensis Spencer Hickman, Societatis Regalis Typographi, 1672, 12mo, portrait). The logic of Ramus was adopted by the University of Cambridge, probably in the sixteenth century. George Downname, or Downam, who died Bishop of Derry in 1634, was prælector of logic at Cambridge in 1590. His 'Commentarii in P. Rami... Dialecticam...' (Frankfort, 1616, 8vo,) is an excellent work. The Cambridge book then most in use was the *Dialectica* of John Seton, first published (Ames) in 1663, and repeated down to 1611 at least: it is noticed by Dr Peacock as the book to some editions of which (from 1570 onwards, if not before, I find) Buckley's arithmetical verses are appended. It is not a Ramist book: the presumption is that Downam was the Cambridge apostle of his doctrine. Ramism fixed a mark upon Cam-

bridge which it has never lost to this day; that is, if the acts in divinity, &c. be still kept in the old form. The distribution of the syllogism into three conditionals, 'Si A sit B, cadit quæstio; sed A est B, ergo cadit quæstio, &c.' is pure Ramism, both as to form and phrase. Never having paid any attention to Ramist logic, I never could understand this form. No one could inform me: even a question sent to the *Notes and Queries* produced no reply except an ingenious conjecture that the *casus questionis* explains Shakspeare's meaning of the obscure words "loss of question" in *Measure for Measure*, act ii. scene 4: a phrase on which commentators were so far to seek that Johnson proposed "toss of question." And so it stood until I happened to propose the difficulty to Prof. Spalding of St Andrews, who replied that an explanation might be presumed if we knew, or could assume, that this form was introduced by *Ramists*. Though cognisant of Cambridge Ramism, I had never had the sense to put the two things together.

I greatly regret the abolition of the *act* for the B.A. degree. It was the most useful of the exercises, and the most *trying*.

which are incessantly used. I insert it for the consideration of those who, for want of advice to the contrary, imagine that the logical gymnastic can afford no higher exercise than the perception of 'No cruel is kind, some cruel is tyrant, therefore some tyrant is not kind', duly chronicled as *Ferison** of the third figure, cousin by the conversion side to *Ferio* of the first. The following *single*, though not *simple*, syllogism is an extract from a letter to a person who had supposed, from some circumstances of character and fact, that a common friend of his own and of the writer must have been the person who had figured in the narrative of a very silly proceeding:—

"We both see clearly enough that he [the hero of the narrative] must have been rich, and if not absolutely mad, was weakness itself subjected either to bad advice, or to most unfavourable circumstances. How then can you persist in identifying him with the friend of whom we are now speaking; who was indeed very rich, and easily swayed, and so far, we will say, not distinguishable from our hero; but who was conspicuous for clearness of head and sobriety of fancy; who never sought serious counsel except from his father's old friends, and you know what men they were; and who passed his youth in severe study varied only by useful exertion, and his manhood in domestic life and country occupations."

Says the man of the world to the logician, I am very clear that two men who are proved to be different cannot be the same: but all I learnt at college about identity and difference, and excluded middle into the bargain, has done nothing towards putting me into a condition *rapidly* to assert or deny that the advocate has put the principle of difference between the rich fool and his rich friend. Here are two complex descriptions one of which contradicts the other. The description of the rich fool excludes him from either of three classes: the description of the rich friend places him in one of those classes: the two cannot then be the same. In the symbols I use—and symbols will one day be the scaffolding of logical education, though useless then, as now, to all who have not mastered them—the argument is expressed as follows. H is the rich fool; h any other person; H' the rich friend; R rich, r not rich; W weak, w not weak; A badly advised, a not so; C unfavourably circumstanced, c not so.

H)) R[M, W(A, C)]; contrapositively, r, m (w, ac))) h;

or r, mw, mac)) h; but H')) mac; whence H')) h; or H') · (H.

The syllogism itself is the web of an argument, on which the tapestry of thought is woven; the *primed* canvas on which the picture is painted. The logician presents it to the world as the tapestry or the picture: he does this in effect by the position he makes it occupy; for he sends the primed canvas to the exhibition. And the world does not see that, though the syllogism be a mere canvas, it stands to the thinker in a very different position from that in which the canvas stands to the painter. Call the historian or the moralist a practised artist at a thousand a year, and I am well content that his structure of the canvas shall be valued at ten shillings a week: it would not hurt my argument if it were valued at a halfpenny. For the painter can and does delegate the preparation of the canvas; the historian cannot *put out* his logic. He must do it himself as he goes on; and he must do it well, or his whole work is spoiled.

* I think as I always did of the admirable ingenuity of these words, for their purpose: they are the most *meaning* words ever made.

I will take an example from one of the unusual forms of syllogism. Say "The time is past in which the transmission of news can be measured by the speed of animals or even of steam; for the telegraph is not approached by either." Is this a syllogism? Many would say it is not; but wrongly. Throw out the *charges*, the modal reference to past falsehood and present truth, the advantage of the telegraph, its *superior* speed, the reference to progress conveyed in *even*—and we rub off the whole design of the picture. But the ground which carried the design is a syllogism. In old form it is *Darapti*, awkwardly.

All telegraph speed is (not steam speed)

All telegraph speed is (not animal speed)

Therefore Some (not animal speed) is (not steam speed).

In the system which admits contraries it is a syllogism with two negative premises, and a form of conclusion unknown to Aristotle: it is, in the symbols I use, the deduction of $) ($ from $) \cdot () \cdot ($

No animal speed is telegraph speed

No steam speed is telegraph speed

Therefore Some speed is neither animal nor steam speed.

When this is presented, a person would naturally ask, What then? The answer to this question is seen when the charges are restored, and the sentence takes its proper place in the whole argument.

V. A great objection has been raised to the employment of mathematical symbols: and it seems to be taken for granted that any symbols used by me must be mathematical. The truth is that I have not made much use of symbols actually employed in algebra; and the use which I have made is in one instance seriously objectionable, and must be discontinued. But it has been left to me to discover this mistake, into which I was led, as I shall shew, by the ordinary school of logicians. If A and B be the premises of a syllogism, and C the conclusion, the representation $A+B=C$ is faulty in two points. The premises are compounded, not aggregated; and AB should have been written: the relation of joint premises to conclusion is that (speaking in extension) of contained and containing, and $AB < C$ should have been the symbol. Nevertheless, $A+B=C$, with all its imperfections, made a suggestion of remarkable character to an inventive friend of mine: while $AB < C$ was both a *suggestio veri* and a *suppressio falsi* to myself. For these things see the second part of this paper.

As to symbols in general, it is not necessary to argue in their favour: mine or better ones will make their way, under all the usual difficulties of new language. There was a time when logic had more peculiar symbols than algebra. Every system of signs, before it has become familiar, as we all remember when we look back to ABC, is repulsive, difficult, unmeaning, full of signs of difference which are practical synonymes* by combination of want of comprehension with ignorance of the want. But it is too certain to need argument that the separation of form and matter requires as many symbols as there are separations.

* A Cambridge tutor of high reputation was once trying to familiarise a beginner with the difference between *na* and *a*. After repeated illustration, he asked the pupil whether he saw the point. "Thank you very much, Mr ——" was the answer;

"I now see perfectly what you mean: but, Mr —, between ourselves, now, and speaking candidly, *don't* you think it's a needless refinement."

In the opinion of Hegel, we are told, Ploucquet's logical *calculus* was the bitterest libel ever vented against the science. So far as this refers to one particular calculus I need say nothing: but, looking on the opinion as one having a general direction against symbols, it ought to be noticed that every exact science is only so far exact as it knows how to express one thing by one sign. Every science that has *thriven* has thriven upon its own symbols: logic, the only science which is admitted to have made no improvements in century after century, is the only one which has *grown no symbols*. To be presented with new marks by which to learn new combinations is to be libelled, because there is a charge of imperfection, tending to destroy credit. But both truth and utility may be pleaded to the indictment. Every little boy has this libel vented against him, when he is first presented with his ABC: he does not feel it, because he is not come to his dignity. If logic, in her maturity, must be vexed with a horn-book, the fault does not rest with those who offer it now, but with those who did not teach her the alphabet when she was young. And I cannot help suspecting that the stern and decided opposition which the follower of the ancients makes to the first introduction of symbols is the feeling of the urchin whose chief objection to saying A was that he knew if he said it he should be made to say B, as no doubt he would.

VI. I shall now proceed to fundamental points, and to some criticism of the common doctrines. Should I appear too free* in my remarks, I desire it may be remembered that my former self is one of the parties assailed. In developing the opinion that all the writers on logic have kept themselves too exclusively within what I now call the *logico-mathematical* field, I do not claim to be an exception, save in a sentence here and there which may contain a germ of my present views. I am especially to deal with the great distinction which is gradually forcing its way into its proper place, usually called the distinction of *extension* and *comprehension*. I do not adopt these terms. First, because, like *denotation* and *connotation*, they are kindred words which might change places with the least possible violence. Secondly, because the distinction of *extension* and *intension* occurs both in what is called extension, and in what is called comprehension. Nor can *objective* and *subjective* be made the basis of the distinction, for both are again in both, though the subjective rather predominates† in one and the objective in the other. I distinguish the two sides of logic as the *logico-mathematical* and the *logico-metaphysical*, frequently dropping the prefix *logico*.

I symbolise *extension* and *intension* as follows. Let A, B, C, be names, no matter how conceived; let X be a name containing *all* that is signified by A, by B, and by C; let Y be a

* In this country, the study of logic has been, for a long time past, and almost up to the present time, either the traditional practice of an old university, or the taste of an isolated individual. A great amount of reaction in its favour, all things considered, has taken place in the last twelve years, as evidenced by the publications on the subject. The consequence is, even at Oxford, a commencement of considerable diversity of opinion, and of plan of teaching: but, in the bulk of the writings, we see the old system, variously patched, except where a wider meaning is given to the word *logic* than it usually bears, and it is taken for a science in which all human knowledge is surveyed in its mode of acquisition. In such a state of things, nothing is more desirable than the most decided

and uncompromising attack from without, conducted on the principle that a useful logic may exist, and directed to the details of the common system, not to the question of its general character. The dispute which has lasted so long has assumed that if there be anything worth having, the common books have it all; a basis on which both sides have agreed that this or nothing is their alternative. A change of question is gradually, but far too gradually, taking place: any assault which tends to expedite the fulness of this change must be a benefit to the science.

† I speak here only of the *subjective* distinction of subject and object. With the true *objective*, Logic has nothing to do.

name of *no more than* is contained under the three, A and B and C. That is, let $X=A, B, C$; let $Y=A-B-C$, in which the hyphens are frequently dropped. Then I say that X has more *extension* than A, unless by casualty B and C be both contained in A: also that Y has more *intension* than A, is more descriptive, more discriminative, more *intense*; unless, by casualty, B and C should only be components of A. I call (A, B, C) an *aggregate*, and A one of its *aggregants*; A-B-C a *compound*, and A one of its *components*. And (A, B) is not A+B, but $A+B-AB$; as pointed out by Mr Boole. The distinction may also be made as follows:—If A and B be aggregants of X, it means that X contains both: if components, that X is contained in both.

A name may belong to an individual object of thought, objectively considered, or to the class in which that object is placed by possession of a *quality*, objectively considered as inhering in it. The name may also belong to the quality itself, and also to the *class-mark*, or *attribute*, the subjective quality, the possession of the mind, by which it can think of the class subjectively. These distinctions are fundamental parts of thought. Thus one name has no fewer than four separate uses: and the battle of the four senses is a large part of the history of logic. There are two reductions of plurality to unity, that of objects to class, that of qualities to attribute. Both are often denied; some maintain that we cannot think of class without the individual object, nor of attribute without an object to qualify by it. But perhaps it is more common in the general world implicitly to deny the subjective unity of class, and the objective plurality of quality. However others may be constituted, I find myself conscious of full and clear possession of both class and attribute, as *second intentions*. Illustration will be useful, and none is better than the oldest. We are in a warehouse full of packages of all kinds: each package has one or more seal-impressions on it, its *qualities*, by which alone we see the existence of the packages. These packages represent, some the material, some the mental substrata about the existence of which so much discussion has arisen: they are perfectly dark, and the seal-impressions shine by a light of their own. We can put together all which have one seal-impression, and so form a class, the members of which might be scattered among other classes, if we sorted by other seal-impressions. Perhaps all the impressions of one design come from one original seal, *universale ante rem*: but this is the question of realism, and is purely metaphysical: our affair is with the sorting &c. of the packages. Certain it is that for our own use we take off on what we call *memory* a seal from each class of impressions, an inverse process, that we may have the means of testing new impressions when we come to them, and that we may always recall the design when we want it. Thus we make the quality, *universale in re*, give us an attribute, *universale post rem*.

The denial of unity in plurality is made by saying that *man*, for instance, thought of as a class, means only the conception of an *individuum vagum* from among the class individuals, who must be tall or short, fair or dark, &c.: also that *attribute* is only *quality* thought of as appertaining to this individual. All but this, they say, is only grasping a name: the conception of a class is only the imagination (calling up an *image*) of an individual. I do not know how it is with others, except from their own report, which I cannot question. But it is not so with me. Procrustes has hitherto been, in most cases, one of the names of a psychologist; a speculator who stretches or shortens the rest of his species to his own

pattern, having previously stretched or shortened himself to the pattern of Aristotle, Plato, Kant, or another.

I believe men in general to be true realists, *post rem* at least. They speak attributively: they allow the *same* feeling to different persons, the *same* quality to different things. This many affirm to be an incorrect mode of speaking: they aver that two persons cannot have the same feeling in the sense in which they can sit at the same table. This assumes that a table is more than a *collection of feelings*. For myself, if I may not say that two persons who die of a stroke of the sun, or two strokes of the sun, are killed by the *same disorder*, neither will I be inveigled by the *usual hypothesis* of matter into saying that they were killed by the *same sun*. It would be easy to frame hypotheses which no one can, of knowledge, deny, under which attributes in the brain should be as real as the sun in the heavens or the rocks on the earth: and this without denying either the existence of matter, or the separate existence of mind; and so that the question whether A gives the *same* attribute, roundness, to both sun and moon, should be the very same question as whether A and B both see the *same* sun.

VII. A man may be allowed to ignore, as a logician, what he admits as a metaphysician: but he must not *deny* it. Some logicians have controverted the plurality in unity, in order to base logic wholly on what I shall presently describe as the *mathematical* notion. One chief object of this paper is to reinforce the assertion that the mathematical branch of logic, the part which has a mathematical principle, has been allowed to overgrow the metaphysical part, and deprive it of light and air. This begins to be admitted, though not in my words: but those who make the admission seem to be trying to grow another branch of the mathematical: which is most conspicuous in the attempt to introduce, by postulation of its universal existence in thought, a complete quantification of the predicate, as a part of the notion of enunciation. It is said that all that enters into the predicate notion is denied of the subject when the predicate is denied, and that in this matter there is no difference between the constitutive and the attributive. This is a hard saying, so long as that which enters a notion enters in the way of the world at large. *Man* is denied of *Bucephalus*, and *animal* enters the notion of *man*; is *animal* denied of *Bucephalus*? No, answers the pluralist, only that part of the notion which belongs to man. The truth is that, to make the whole fit on the mathematical abacus, the unity of attribution is denied, and there is left but a class of qualities, distributed, one a piece, among the individual class objects. Alexander of Macedon, Newton, and Leibnitz, have three human natures. Leibnitz is not Newton: therefore every attribute *comprehended* in our thought of Newton is virtually denied of Leibnitz, be it his humanity, be it the *wearing of his wig awry*. Now all this is in the form of thought, because it can be thought: it is therefore a part of logic. The qualities of Newton are not the qualities of Leibnitz, because Newton is not Leibnitz. It is however a part of the mathematical side. The class may be divided into individuals, the attribute, or class-mark, may be made to give thought of a class of individual qualities, as much separated as the individuals of the class of objects in which they inhere. Nay, even the perception of the desirableness of putting on the right class-mark may be made to generate a class, a class of *desirablenesses*: one perception of the propriety of placing Newton in the class man; another for Leibnitz; and so on. But the very logician who thus lays down all thought on a meagre

abacus will—at least I see from his writings that he always *does*—return to unity the moment he drops the counters with which he was acting his *professional* part. The distinction which he played at abrogating, the distinction between the genus in species of metaphysical composition, and the species in genus of mathematical aggregation, will recur to his nature before the pitch-fork is well out of his hand. The attribute of humanity will then be in his mind common to Newton and Leibnitz, and so will that of *phenacostrepticism*, if he must needs suppose that the wigs which covered those vast masses of thought were given to unseemly rotation about their polar axes.

VIII. I now come to the strongest of the differences between my own views and those which have been recently propounded. A clear detail of the point is due to the eminence of those from whom I differ: and all the remainder of this paper will contain very frequent illustrations of a distinction which I am confident has been wholly misconceived.

Aristotle saw that though the genus contains more than the species, more extent, more *things*, yet the species also contains more than the genus, each *thing* takes more *description*, more fulness of quality. Our own language will make the distinction expressively:—animal is more than man; *and* there is more in a man than in an animal: animal is horse, dog*, &c. as well as man, but a man has reason, which an animal other than man has not. All the attributes make up the *ούσία*, and accordingly (*Categories*, cap. 5) the species has more *substance* than the genus; τὸ εἶδος τοῦ γένους μᾶλλον οὐσία. Again, (*Metaphysics*, lib. iv. or v. cap. 25) the genus is called part of the species, but otherwise the species is part of the genus; διὸ τὸ γένος τοῦ εἶδους καὶ μέρος λέγεται ἄλλως δὲ τὸ εἶδος τοῦ γένους μέρος. In the *Physics* (lib. v. cap. 5) various illustrations are given. The sense of this is very clear; as follows:

Species in genus. All man is in animal: whole class *man* part of class *animal*.

Genus in species. All animal is in man: whole *attribute* animal component of attribute *man*.

The whole of man is in animal, European, Asiatic, &c. The whole of animal is in man, body, organisation, sentience, want of food, power to get it, instinct of reproduction, &c. But *man* is not all *animal*, witness horse, dog, &c.: nor is *animal* all *man*, witness all the attributes which make up the distinction of *reason*. Hence we may say, in one reading, that man is universal, animal particular: in the other, that animal is universal and man particular. And this is the great distinction, to the sides of which it was always intended to give the words *extension* and *comprehension*.

This distinction was very little attended to. It always had its scholastic name: the species as part of the genus was a part of the *logical* whole; the genus as part of the species was a part of the *metaphysical* whole. The schoolmen were no mean proficient in the art of saying what they meant: and they meant to keep 'species in genus' within logic, and to drive 'genus in species' into metaphysics.

* Since putting down these instances, I happened to see in the recent English translation of Aristotle's metaphysics (l. iv. c. 26) that man, horse, *god*, are *animals*. I took it for granted that a transposition of letters had taken place in the last

word; but on looking at Aristotle, I found θεός. The confusion arises from the practice of translating ζῶον by *animal*: it should be *living being*; the English word *animal* agrees with the middle Latin word in meaning *corpus animatum*.

The *Port Royal Logic* is said to be the first modern work in which the distinction is insisted on; the use made of it is not very extensive. But it is correctly conceived. It is said, for example, that the attribute (predicate) of an affirmative proposition is affirmed according to its *whole* comprehension: and also that the negative proposition does not separate from the subject *all* the parts contained in the comprehension of the attribute: meaning, for instance, that to say *Bucephalus* is not *man* does not separate *animal* from *Bucephalus*. I do not think that many works carry on this distinction: for, had there been many, I suppose my own research, limited as it is, would have detected more than one. But I have only* found it in the *Institutiones Philosophicæ* of J. Bouvier of Mans (third edition, Mans, 1830, 12mo).

The logicians who have recently contended for the revival, or rather the full introduction, of the distinction of extension and comprehension, have completely passed over the *change of the quantity*, and, so far as I see, make it only the distinction of number of objects in a class, and number of *marks of class*, or concrete qualities, one to each. So that, with them, quantity of comprehension is the same thing as quantity of extension: six of one, half-a-dozen of the other. For example, when one of them reads in extension 'all metals are some shining things' he converts it into a proposition of comprehension as follows—'The notion of *some shining things* attaches to the notion of *all metals*.' It ought to be said that the *whole* notion of *shining*, with *all* its components, badness of radiation, hurtfulness to the eye if too long continued, fitness for mirrors; difficulty of good imitation in painting, &c. &c. all form a part, and, as it happens (but this is not necessarily contained in the proposition), a part *only*, of the notion *metal*: which contains besides, hardness, conduction of electricity, &c. &c.

Another powerful writer sets out a table of descent from the *summum genus* A, which contains species E, which contains I, which contains O, which contains U, which contains Y, which contains the individuals z, z', z'', &c. As in animal, mammal, man, European, Greek, Athenian (*i. e.* Socrates, Plato, &c. &c.) Beginning with z, we are told this subject is (contains *in* it the inherent attribute) *some* Y. Here Plato contains in himself as an attribute, *some* Athenian. Now he is contained in the class as *some* (one) Athenian: but he contains in himself *all* attributes essential to an Athenian. As an individual, he helps to make up Athenian (class of men): but *all* that goes to the composition of an Athenian man is in him, the *whole* of every attribute must be awarded to him as a quality. If an Athenian must talk Attic Greek, so must Plato; if an Athenian must look down on a Spartan as a fellow not fit to talk to nor to dine with, so must Plato. The next step is 'All Y is some U,' or 'All Athenian is some Greek.' But it should be:—All the attribute Greek is part of what we think of under the attribute Athenian. Any one would suppose my quotations were meant for class readings; but it is not so: the readings in extension are given as 'Some Y is z' and 'Some U is all Y,' &c.

It seems that by a strong bias in favour of the mathematical side of logic, the decomposition of the attribute has been discarded in favour of the disaggregation of a class of qualities. But whether this be done avowedly, in opposition to the ancient distinction of

* Since this was written I find—or rather *re-find*, for I must have seen it—that a learned reviewer of myself and others has hinted an objection to the growing theory of his day, in a manner which implies that he inclines to the old view. I find

also that he admits it is the old view. But his objection is hesitatingly given, and with an avowed expectation of refutation; though this I suspect to be rather deference than doubt.

logical and metaphysical whole, or whether those who do it imagine themselves in accordance with the old writers, is a point which I have not seen settled, nor even alluded to, by those to whom alone belongs the power of deciding it. Except so far as this. The preceding table of descent, from the *summum genus* to the individuals, was partly written in answer to passages of my second paper in which the view of the *Port Royal* logic was taken; that is, the affirmative proposition was made intensively universal in the predicate, the negative proposition intensively particular. I and some others were declared to be wrong: but whether the *Port Royal* authors were among those others was not stated, though I suspect that my reviewer mentioned in the previous note is included.

Of course no one can object to the truth of the proposition that some individual instances of the quality animal are distributed, one a piece, among all men. This proposition can be thought, and is thought: and it is not quite the same thought as 'All men are so many animals.' But this very subordinate distinction is not the one which Aristotle laid down, and which he obtained from the necessities of human thought. He meant that animal contains man, for animal is aggregate of man and brute: but (*ἄλλως*) man contains animal, for man is compound of animal and reason.

IX. The quantification of the predicate has been the guide under which the school against which I contend has been led to take a reduplication of the mathematical side of logic for an introduction of the metaphysical side. This quantification they justify by the postulate that logic ought to be allowed to find language for all that *is* contained in thought. Whether usual thought does quantify the predicate may be doubted: but this does not matter; for the postulate should have had *can be* instead of *is*. It is the business of logic, as a mental* gymnastic, to put into activity all the powers, if any, which ordinary life allows to lie dormant. Of every mode of thinking, as of every mode of using the muscles, it is certain that it was meant for a purpose, and for a purpose which cannot be so well accomplished without it. Accordingly, the syllogism of the predicate quantified by postulation has its proper place: I believe that place to be, as I shall point out, in company with the common form of syllogism, and the numerically definite syllogism, in the *arithmetical whole*, or whole of *first intention*.

But there is one mode of thought, very often expressed in common life, and almost always implied, which logic has wilfully neglected, to the serious curtailment of her field of operation. Her pictures are not bounded by a frame, with landscape and sky definitely painted up to the sides of the rectangle; but have only a foreground with an indefinite back shading, equally signifying, under the type of an exclusion, the distant hill and the intermediate river. The *contrary* of the name or term, the not-X of the X, is made only aorist, indefinite, standing for more or less, no matter which, of the whole universe of thought. But not only is common

* A learned writer denies it this character, in its primary purpose. He says that logic is no more designed primarily to give men facility in the practice of reasoning than a treatise on optics is intended to improve their sight. The parallel is imperfect. Suppose that optics neither had, nor could have, other subject-matter than spectacles; that men did nothing in their waking moments without making spectacles; that religion and morals, life and manners, food and clothing, &c. &c. all depended in the highest degree upon every man, or most men,

making those spectacles well which they must all make well or ill. In such a case 'Optics, or the art of improving defective vision' would be no very absurd title: nor, as man is constituted, is there any great objection to 'Logic, or the art of reasoning.' It would be better to say 'Optics, or the form of spectacle-making, with a view to the improvement of vision' and 'Logic, or the form of thought, with a view to the improvement of reason.'

thought conducted in a limited universe, but this so palpably that express mention is seldom needed. A person strikes into a conversation to deny the first he has heard of it, and is instantly put down by, We were talking of ——. A proposition, false in the whole universe of thought, is true in the universe of the speaker's argument. The first sentence in Euclid is a marked instance: a point is that which has no part. My firm conviction that Euclid was a man and not a myth *has no part*: I cannot dichotomize it; is it then a point? Any one can answer that Euclid was talking of space, not of historical beliefs and convictions: space and its laws are the universe of his book. The definite universe, the duality of every classification, exclusion as definite as inclusion, should be of the *logica docens* because it is possible, and of the *logica utens* because it is actual: and fundamental in both.

X. We think by class, or by attribute, under relations. The relation which must take precedence of all others, because it must be present in the mere idea of nomenclature, is that of whole and part, of containing and contained. This relation, and its concomitants, I call *onymatic* relations: and it appears to me that, onymatic being absent, *formal** has supplied its place. There is a fourfold mode of thought, which logicians confound into one by a fourfold use of the word 'is.' I denote and symbolise the four modes as follows, proceeding only by an instance, and leaving the full description of the relations for the summary in the second part.

1. *Logico-mathematical*; class aggregant of class. The class *man* included in the class *animal*. Always intended where symbols are both common parentheses, as)) () &c. .

2. *Logico-physical*; attribute predicated of class. Animal a quality of every man, an attribute of the class. Symbols)] (] &c.

3. *Logico-metaphysical*; attribute component of attribute. The notion animal a component part of the notion human. Symbols]] [] &c.

4. *Logico-contraphysical*, attribute† subjected to class. Human, an attribute to be looked for within the class animal. Symbols)) [] &c.

1. *Mathematical*. The logicians excluded—or rather tried to exclude—all predication except reference of class to class: accordingly, genus as an aggregate of species they called the *logical* whole. The name is good so long as the exclusion lasts, and no longer. Aggregation of individuals into species, they called the *mathematical* whole: I call it the *arithmetical*. And aggregation of species into genus I call the *mathematical* whole: mathematical, because summation of parts is a mathematical process; but not necessarily *arithmetical*, or proceeding by enumeration of *similars*. The difference between species and individual is, in some points, extralogical. The logician, as such, never knows whether he has or has not specified down to an individual, or even down to nonexistence, at each or any step of the process. His stoppage at an *infima species*, composed of many individuals, was his own fiction. Begin from animal, and compound successively the *differentiæ*, human, Roman, ancient, general, conqueror of

* The more I read of the common statements about form and matter, with the word *onymatic* in my mind, the more does the conviction grow upon me that logicians have taken the distinction between forms which are and which are not onymatic to be the distinction between formal and material.

† *Nec quarta loqui persona laboret*. It seems to be a rule

that every quaternion of logic shall contain one member who is to be considered a disgrace to the family, if not entirely disowned. Of the four universal propositions, one, marked by me (·), is unknown to the logicians; the same of one particular,) (. We all know what a bad character the fourth figure has had, ever since it got a footing as a poor relation.

Gauls, writer of his own campaigns. No one knows whether we have or have not specified down to Julius Cæsar. Add *surviving author*, and we are safe enough: add *composer for the pianoforte*, and we are morally certain we have an empty box. But logic takes no account of the actual effect of differences upon the numerical strength of the species.

Extension and intension both exist, but extension predominates. We often think of class as aggregate of classes, seldom as compound or common part of classes. We hardly reconcile ourselves to the idea of the common part of two classes as a *compound*: by habit we slip into the notion of the attribute of the common part as compounded of the attributes of the two. Thus *marine* is a joint class, both *soldier* and *sailor*: but we rather say the marine, the individual, unites both *characters*.

2. *Physical*. This is the most common mode of thought in man's *nature*, as well as in *physics*: and my use of the word is not far from that made in the old *totum physicum*. I mean that this reading is the most common use of the word *is*: especially in controversy, which is most often about the attributes of things and actions. Man is born and educated a mathematician as to the subject of his propositions, a metaphysician* as to the predicate: he thinks attributively of class in every wrong way and some right ones. His universals are necessities, whether of inclusion or exclusion, not enumerated individual facts. One great use of logic is to teach him the mathematical mode; that is, to make it more of a habit: one great use of natural history in liberal education is to bring down the metaphysical habit, and raise up the mathematical one, until they are more nearly equipollent. The natural *historian* predicates of class in class, arranges facts by facts: he savours of the *physiologist* so soon as his predicate becomes attributive. The logician attempts to point out the human fault and mend it in much the same way as a social reformer would attempt to improve a rude and dirty peasantry, if he should begin by the assurance that they had always lived, and were living, in neat glazed cottages, into which no pig had ever presumed to thrust his snout; and that all they had to do was to become aware of the fact. He assures the beginner that when he said snow is white, he had not in thought a necessary attribute, for he never had any attribute at all: he meant that snows are *some* white objects, with a distinct reference of possibility to others unnamed. Logic would have been of greater use if it had been distinctly announced that one of its great aims is the abatement of *natural philosophy*, the increase of the power

* Contending as much as any one for the distinction between logic and metaphysics, I must yet remind my reader that logic is concerned with the *whole form of thought*. The *necessary* form of thought for all practical teaching, is any form which all men *actually have*, whether we can imagine them to be without it, or not. If every man, saint, savage, or sage, have a certain form of thought, it is the business of logic to teach him to use that form correctly. Now it is a fact that, in their daily thoughts and judgments, all men are metaphysicians, and always have been: and the uneducated more than the educated, and children more than grown people. We have all our ideas, which we are constantly applying, about natural and unnatural, necessary and not necessary, essential and not essential, repugnant and not repugnant, cause and effect, dependence and independence, possibility and impossibility, &c. &c. &c. These are our strong points. We set out in all our

inquiries with clear ideas of the naturally possible and impossible: we sometimes feel our ignorance as to what *is* and *is not*, but never as to what *can be* and *cannot be*. Now whether our metaphysics be true or false, it is the business of logic to take care that it be logical. Even if it be the truth that no notions have either essential connexion, or necessary repugnance, it is a law of our minds to *envisage* them as having both, and it is a law of our language to talk of them as having both. But many a man who is metaphysician enough to know that reason is essential to man, is not logician enough to avoid the inference that it is *therefore* repugnant to the nature of brute. A man may, in his closet, be both an idealist in philosophy and a mathematician in logic: but the moment his foot is on the pavement and his eye on the world, realism and metaphysics resume their sway.

of referring thing to thing, and of inferring from classes, the majesty of ignorance having been accustomed only, or chiefly, to the assignment of attributes. Common thought deals mostly in double universals: the metaphysical whole applied to the mathematical whole. And so the old logicians often phrased it: they said that in a universal affirmative the whole predicate is applied to the whole subject. Some logicians deny the existence of this form, in logic at least. Declaring that the word '*is*' shall be, ought to be, the only copula, in its meaning of *identification*, they declare that attribute can only be predicated of attribute, or class of class. With this I have nothing to do, except to appeal to the world at large whether by '*is*' they do not intend to convey predication of attribution and subjection of class, at least as often as any other sense. To me the "elegant extracts" of the logicians are no answer: I deny their right to exclude any form under which men *do think*; and I contend for the *whole form* of thought.

3. *Metaphysical.* This is an old and well-known use of the word, appropriate both to its etymology and to its derived meaning. If chemistry had been known as it is now, that which was called the metaphysical whole would have been called the *chemical* whole. The manner in which the concept man is composed in our thoughts of animal and reason is a very different thing from that in which animal is made up of man and brute. The logicians say that a concept is the *sum** of the attributes which it comprehends: the mathematician easily corrects them. *Animal* is the *sum* of *man* and *brute*: withdraw *brute*, and the notion *animal* is not destroyed; *man* remains, and some *animal* is left. In fact, *animal* is made up of *human-animal* and *brute-animal*. But in *comprehension*, to use his own term, being the view of which the logician was speaking, man is a *compound*, not a *sum*, of *animal* and *reason*: withdraw *reason*, and the notion *man* ceases to exist. *Man* is not added up of *animal-man* and *reason-man*. Again, in aggregating animal, we may conceive all man to be in Europe, and all brute in Asia: but in compounding man we cannot conceive all the animal to be in Europe, and all the rational in Asia. Put an impossible species into the genus, and the rest are not affected: put an impossible component into the notion, and it ceases to be a notion. A black-white horse is a subjective nonentity: nevertheless, if we divide horses into black, white, and black-white, the genus is still usable; it is only a three-stall stable with one stall locked up and the key lost, or never made.

Extension and intension both exist in the metaphysical, but intension predominates. The attribute human may be extensively subdivided into attributes, and also into individual qualities. The misconception of the logicians which I have discussed at length consists in seizing the extension of an attribute, and missing the intension.

When the old logicians puzzled themselves with what they called the *indefinite* proposition,

* The illustrations which follow are familiar to the mathematician in the distinctive properties of $a + b$ and ab . Such a mistake as that made by the logicians would be, in mathematics, equivalent to substitution of logarithms in place of their primitives. This mistake was made by the old geometers, when they styled *composition* of ratios *addition* of ratios: it appears in Euclid's *duplicate* and *triplicate* ratio. But here it was not all mistake. The logarithmic idea was present in

an undefined and uncomprehended form: and, when the time arrived, the *measure of the ratio* was easily accepted as the definition of the *logarithm*. Those who have affirmed that Archimedes invented logarithms, were right so far as this, that Archimedes or a predecessor invented the *integer* part of the notion, if indeed it be not more correct to say that the integer part of the notion invented itself. Napier invented the *fractional* part of the notion, and applied all.

Man is animal, and tried to make out whether it should be universal or particular, they were dealing with the metaphysical form of speech, attribute predicated to be component of attribute. Nor is this the only instance in which the metaphysical intruded itself within the mathematical boundary. To me the old books read like a running fight between the two modes of conception: not a pitched battle between regimented ranks under the banners of *quid* and of *quale*; but a mob-scuffle in which there is neither front nor rear. It has been said that logic ought to be the uncovered skeleton: this was said of the mathematical view. The old logicians clothed the bones with a little metaphysical muscle: so that, instead of presenting the examination of a skeleton in one compartment of a museum, and of muscular fibre in another, logic looked like an inquest on a starved pauper in the workhouse.

4. *Contra-physical*. This form is rarely in use. In human thought, the more frequently one of two inverse forms occurs, the more rare is the other. But it is only in a result to be expressed that this reading is a rarity. When the old metaphysician was hunting the species in a genus by a *differentia* which was of the *essence*, he was engaged in a contra-physical process.

All these words express distinctions which are purely formal. The *logico-metaphysical* is only the form, law, mode of entrance, of the *metaphysical* notion, so long as humanity and phenacostrepticism are equally admissible as attributes of Newton and Leibnitz. I shall make no other answer to the charge of *materialism*, except this, and a reference to what I have already said. If all that precedes contain any matter, find the form of it, and either point it out as existing, or introduce it. If the phrases savour too much of the material, either sublimate them into formalism by mental chemistry, or find better phrases.

Even the words *necessary* and *contingent* must be allowed a formal sense, which has an eye to the mode of action common to two kinds of matter. Real necessity only exists in the laws of thought, applied to matter of which we form judgments *à priori*: popular necessity exists where contingency has never shown two different kinds of result. Instead therefore of widening the bounds of logic to introduce the consideration of true metaphysical necessity, it is to be part of logic that the necessity which can be seen *à priori* or from *à priori*, *the three angles of a triangle make two right angles*, is not of the same material as the necessity inferred from uncontradicted contingency, *man is biped*, but that the two have a common form in thought, or set the machinery in action in the same way. The same may be said of other notions of pure metaphysics: the subjective and the objective are of one form of process in logic.

XI. The only copula which logicians provide, for all the modes of reading, is the substantive verb '*is*.' Nor is another wanted, so long as one relation only is used: but more must now be found. To express in language all that is contained in thought, is to divide in language all that is divided in thought. We must have definite *words of relation*, *anaphorical* or *schetical* terms: and these I shall presently propose. But an ambiguity, to which I now proceed, nipped the use of schetical words in the bud.

Dichotomy, in mathematics, has an extreme case which is always included. If $c = a + b$, the terminal instance $c = a + 0$ is admitted and accounted for, or else excluded under the showing of the particular problem. Logical dichotomy, class into two classes, has the well-known quantitative division of *all* into two *somes*. The word *some*, in mathematical meaning, ranges

from *none* to *all*, both ends included. But in logic, the exclusion of the terminus *none* is an absolute necessity: its inclusion would bring under one word existence and non-existence, would make falsehood the extreme case of truth. But it is otherwise at the second terminus. Ambiguity here exists in thought and in usage. Accordingly, logic has always recognised two kinds of *some*; that of *terminal ambiguity*, some-it-may-be-all; and that of *terminal precision*, some-not-all, the *some* of common life.

Some-not-all, separated by specific difference, and *all*, are in the relation of species and genus; a relation which is lost when *some* becomes *all*, in the old sense of the words species and genus. But in 'All X is Y' the force of Y is 'some or all Y, as it may happen.' It is 'All X is some-it-may-be-all Y.' The logicians frequently define some as not-all in the outset, and then proceed to use it with an ambiguous terminus, by expressly laying down that 'Some X is Y' does not allow inference of 'some X is not Y.' This confusion still continues. We have been assured that 'All X is some Y' is contradicted by 'All Y is some X,' a proposition which cannot be made good except by *some* being declared *not all*.

This distinction totally prevented the expression of any syllogism as a combination of relations. No one could say that the process in *Barbara* is expressed by 'Species of species is species.' This last expresses the act of mind in one of what I have called complex syllogisms, each containing three simple syllogisms. The process in *Barbara* is as follows;—That which is either species or coextensive of that which is either species or coextensive of Z is itself either species or coextensive of Z. Add to this that while the propositional forms were more of the mathematical character, the predicables were more of the metaphysical.

XII. I now come to the proposition, its form, quality, and quantity. For the distinction which I draw between the technical sense of *affirmation* and *negation*, and the general words *assertion* and *denial*, I refer to the second part of this paper.

A beginner in logic, on hearing the propositions 'Omnis homo est animal,' 'Aliquis homo est doctus,' not only as first examples of predication, but as the ultimate instruments of syllogism, might be expected to say—I was told that logic was chiefly, if not wholly, conversant with *second intentions*; Pray what has become of them? The fact is that philosophy, in spite of her proud tendency towards the universal and the necessary, and her contempt for what I call the arithmetical whole, as vague, partial, and contingent, actually proceeded in this arithmetical whole, not merely in the convenient expression, but in the scientific structure, of her propositions. Her forms were *all* and *some*, as the fundamental discriminators of propositional enunciations. Her good intentions as to second intentions—in adopting which she took a course worthy of herself—were rendered of no effect, partly by the habit of the arithmetical whole, partly by the want of the definite universe, partly by a preference for the affirmative over the negative; the first of a tendency towards the contingent, the second and third of a tendency towards the necessary and universal. She saw, I suspect, that omniscience need never use form of denial, because it is in possession of the counter-affirmation. All denial is ignorance: no one need rest in 'No A is B' if his knowledge will allow him to say 'Every A is C' where C and B are of essentially and visibly repugnant attributes. Or, to descend to common life, no one replies by a simple negative to 'Does he live at No. 42?' if he know that No. 43 is the true number. Vieta, an accomplished pupil of the schools, caught the

dislike to negation, and did his best to avoid subtraction: he used artifices *contra vitium negationis*; but algebra beat him.

Philosophy, again, which scorned the idea of the *εἶδος εἰδικώτατον* descending to the individual, as savouring of the arithmetical whole, had to work in this whole through all the syllogism, partly because she insisted on raising the *γένος γενικώτατον* up to the whole universe of thought. When *all* and *some* were selected as the exponents of quantity, no reason was ever given for the exclusion of *most* and *fewest*, or of any of the signs of definite ratio of part to whole called fractions. A reason could have been given, and I shall come to it; but philosophy never gave it, within my* reading: the light of second intention shone but dimly into the arithmetical whole. The considerations which I shall proceed to offer are destructive of the right of the numerical syllogism to a place in the logic of the two opposed wholes: but they equally destroy the right of the common form of syllogism, under both quantifications, natural and postulated. All go together to the arithmetical whole, in which all are formed, whether the *some* be more or fewer, vague or definite, all, some perhaps all, some not all, most, nearly all, two-sevenths exactly, two-sevenths or more, two-sevenths or thereabouts. I cannot see how it is possible, under any effective understanding of the difference between first and second intentions, to deny that the common proposition *speaks* by first intention; though of course those who use it may *think* of class or attribute. The arithmetical whole is subordinated, though with different degrees of affinity, both to the mathematical and to the metaphysical wholes: but the habit is to refer it to the former, and for a reason we shall see.

XIII. Taking the mathematical form first, and dichotomising the universe in two ways, by classes X and not-X (x), and Y and y, the onymatic relations of class to class can be predicated without any explicit dichotomy of class, whether vague or definite. The relations are *inclusion* and *exclusion* (inclusion in *contrary*); the judgments, *assertion* and *denial*.

	Mathematical Form.	Arithmetical Form.
A	I assert the inclusion of X in Y	Every X is Y
O	I deny the inclusion of X in Y	Some Xs are not Ys
E	I assert the exclusion of X from Y	No X is Y
I	I deny the exclusion of X from Y	Some Xs are Ys.

Here the classes X and Y are treated in their philosophical unity: the common reading represents objective verification. What is your right to deny the exclusion of X from Y? Answer, this X is a Y, and this, and this, &c.

Quantity is here of no fundamental account: but if not a root, it must be a branch. The objective verifications tell us in the common way the story of universal and particular terms. But the objective and enumerative character has led to much extra-logical discussion on the

* There is hardly an imaginable speculation on thought which is not to be found in the vast number of large volumes by powerful authors which have descended to us. It is not an uncommon mode of replying to a claim for the introduction of this or that into logic, that some Optimus Albinus or Pessimus Niger—as the case may be—mentioned the matter at some date preceding 1600. With this I have nothing to do.

That an opinion has been held before now, and has not gained room in the *quod semper*, &c. is no argument at all: and if it were, it would come with no effect from those who are now pressing the point that the whole of one side of logic, though known to and hinted at by both the illustrious writers above mentioned, has never been put in its proper place.

syllogism. The common form seems to make the whole prove no more than must have been proved in establishing the part. It is only an appearance: but there is substantial neglect in omitting to notice that the syllogism, as logical, has nothing to do with the sort of vindication under which its premises are advanced. If there be a logical necessity that every Y is Z, then X being Y, X is Z. Let the necessity be from *à priori* deduction, let it be the imperfect necessity of induction of the past made deduction of the future, or let it be the *à posteriori* necessity of a complete induction, the syllogism is one and the same act of mind in all cases. The full mathematical form includes all these cases, and shews their inclusion.

The above forms leave only a contingent place for the additional propositions which enter when the predicate is quantified by postulation of every distribution of *all* and *some*. It *may* come out that X and Y are identical in extent: this is one case of A. It *must* come out that some X is not some Y, unless X and Y be singular and identical. The first is to be referred to the forms of terminal precision, the second to a notion antecedent to propositional enunciation, and connected with the purposes and distinctions of nomenclature.

XIV. The idea of enumeration of individuals does not afford the most satisfactory basis for a doctrine of logical quantity which shall put the counter wholes, mathematical and metaphysical, into complete correlation.

In the mathematical whole, the logicians often conceal enumeration by speaking of *extent* instead of *number*: not 'every man is one of the animals,' but 'All man is part of animal.' Very strange is it to a beginner to hear of the *extent* of the term man, and of parts of that extent, as if the notion were capable of continuous accretion, and each new birth put a little bit more man into the extent. To me, when I first heard this language, it seemed as if the notion *man* had been treated after the manner of a dish of potatoes *de-individualised* by being skinned and then mashed together. There is perhaps in the geometrical idea some help towards the expression of class as a unit, because number is connected with the notion of partition in a closer way than area. Still, the attribute compounded of attributes does not seem at once, and without effort, to correlate with the class aggregated of classes.

If we subdivide a class into four others, there is an amount of information in the four, as four, which we are not conscious of when we see four attributes in an individual object. If the worthy Jesuit Gaspar Schott had announced that the number of beatified existences on whose aid man could rely was the 256th power of 2, there would have been an intelligible basis of comparison with other things: how many to each man, what reduction by probable increase of population in a given time, &c. would be matters of approximation for an actuary. But when Schott announced 2^{256} as the number of graces and glories of the Virgin, no comparison could well exist within the limits of attractive speculation. For aught we can say, there may be 2^{256} distinct powers in human reason, developed or undeveloped.

In classification, we know that we arrive at a true *infima species*, the individual: for from the individual we start, and therefore to the individual we can regress. But in an attribute we begin with the compound; and our knowledge of simple substances is not yet attained, far less our atomic theory. In the case of a simple perception, as *white*, we may just distinguish brightness and tint, but we can go no further: the prism which decomposes the cause does not decompose the effect, does not give separate perceptions of which we were perceptively con-

scious in the compound. Again, in disaggregating* a class, we have a distinct idea of *inco-partient aggregants*: but in decomposing attribution, we are seldom sure of *incommunicant components*. *Human* is compounded of rational and animal: here we are sensible of a true dichotomy; according to our notions of these terms, the animal demands no essential component of the rational, nor the rational of the animal. But into what two certainly incommunicant attributes shall we divide *rational*? *Capable of abstraction* is one attribute; but what is the other? Psychology cannot answer. When the controversy about decomposition of reason begins, thick darkness rises about the wrath of the combatants, and veils the unutterable fight, as in the case of Yamen and Kehama: with this difference, however, that the mist does not clear off at the end, and shew us which has won the drink of immortality. Again, in phrenology, I hold it established that parts of the brain are separate machineries having their modes of connexion with different feelings or modes of mental existence. But who can name these parts? Grant that three of them are known to exist in *veneration*, *combativeness*, and *tune*, what are the components of human power which belong to all the three states, or to any two? A certain style of music conduces to the action of veneration, another style to that of combativeness: what component unit-faculty in the organ of music conspires with a correspondent unit in the organ of veneration by which the *organ*—now meaning what the old Presbyterians, of whose organs of veneration it drew out the wrong stop, called the ‘kist fu’ o’ whistles’—acts upon both? All these are questions which can only be asked in illustration of the difference between composition of attribution and aggregation of extent. We go as far as we can, and we try to see what we can: to ask a question is a step in knowledge, and even if there be no answer it is a preparation for an answer. In the present case we realise the false analogy of the assertion that a concept is the sum of its attributes; and, perceiving how truly metaphysical is the process of decomposition of attribute, we raise a contrast which throws light on the exclusively mathematical character of the disaggregation of genus into species.

We want different words to signify quantity of extension and quantity of intension: the difference is that of *quantitas* and *copia*. The world is in possession of the word *force*: it speaks of a term used in its complete force. In fact, as I found out after I had completely organised the second part of this paper, the world has got beyond the logician’s abacus in this point, as in others. Corresponding to quantity particular and universal, I shall, in metaphysical enunciation, use the terms complete and incomplete force.

Before illustrating this matter, I must observe that there are two forms of quantity: the extensive, used in common logic, the intensive, not used. Either quantity is universal when its element, be it aggregant or component, may be thrown away at pleasure: particular, when it may not. Thus, the class man is contained in the class animal: man is extensively

* At first sight we might imagine that one of the fundamental distinctions between class and attribute is this, that a composition of classes introduces no new individuals, and puts no individual into any class in which it was not before: but a composition of attributes may introduce a new attribute, not belonging to either alone. Thus to the attribute *metallic brilliancy* belongs the attribute *destructible by oxidation*, which neither belongs to *metallic* alone, nor to *brilliancy* alone: to

mortal reason belongs the attribute of capability to believe in a *future state*, in the common sense of the words; which capability belongs neither to mortality without reason, nor to reason without mortality. But this, as happens in so many other cases, is of the usual tendency of thought, and not of necessity. Speaking in extension, we have but been saying that the class AB may be wholly contained in classes which wholly contain neither A nor B.

universal, because we speak of its aggregants separately; each aggregant is animal. Throw out any class of man, and the proposition is only crippled, not falsified. But animal is particular, extensively: we cannot throw out any arbitrary formation of class we please, savage animal for instance, because men may be among them, and it need not be true that All man is (in what is left of) animal. Now pass to intensive quantity (which we shall call force when we speak of attributes) mathematically considered. The quantities change names; and this always happens: the extensive universal is always the intensive particular, &c. *Man* is intensively particular, and *animal* is intensively universal, in the proposition above. We may reject any component of *animal*: man is in the class indicated by the remaining compound. But we may not at pleasure reject any component of *man*: for in so doing we may reject a restricting class which takes the common part of the remaining compounded classes out of *animal* in some part of its extension. Speaking metaphysically, *animal* is a component of *man*: *animal* enters in its complete force, but not man: all the attributes of *animal* compound into a component of *man*.

As another instance, suppose 'I deny the co-exclusion of X and Y.' When a relation is convertible, it is convenient that the word should denote it: so, instead of saying that X is an external of Y, I say that X and Y are co-externals. Here X and Y are both extensively particular: we cannot make the denial of any aggregant of either, necessarily. For this reason they are both intensively universal: I deny that any component of X is excluded from any component of Y. In the metaphysical reading, it will be 'I deny the repugnance of the notions X and Y'; and both have complete force. Speak thus of metallic and fluid, to both of which belongs mercury: in thus speaking, I deny that brilliancy is repugnant to equality of pressure; I deny that high specific gravity is repugnant to mobility: either of these repugnances would create repugnance between *metallic* and *fluid*.

XV. The following symbols will be used:—

	Mathematical Reading.		Metaphysical Reading.
X) or (X	X Extensively universal or intensively particular]X or X[X of complete force
X(or X)	X Extensively particular or intensively universal	[X or X]	X of incomplete force.

I call this notation *spicular*, a name first given in derision, but not the worse for that: it is better than *parenthetic*, which has a derived meaning.

XVI. In the old use of the word intension, it referred to intensity of degree, a kind of extension, since there was more or less of the same; but continuous, not increasing by individuals. We may distinguish, when needful, between intensity of degree and intensity of composition: the two kinds are of the same logical power. We may dissect class until we come down to the individual, either by successive intensifications of composition, or of degree: some do one thing, some the other, and dispute arises on the result. Thus one man arrives at his highest member of any class, poet, artist, general, &c. by the greatest intension of degree of the attribute on which he most admires the merit of the class; another by greatest intension of composition of constitutive attributes; a third balances the two.

XVII. I have stated that I consider the ordinary form of the syllogism as belonging to the arithmetical whole, as dealing with first intentions and objective verifications. The syllogism of each of the opposed, or rather confronted, wholes of mathematical and metaphysical thought, is of second intention, and deals with the notions so called. It is in fact, *combination of relations*: the act of mind by which we see that the A of (the B of Z), or the (A of B) of Z, is thinkable under one relation. Here the compound relation, or combined relation, may be represented by AB, but by no one except a mathematician who is used to the *functional* symbol, and to the idea of $\phi\psi(xy)$ in its distinction between the mode of composition of x, y , and that of ϕ, ψ . I use the word *combination* instead of *composition*, to avoid raising this question, and the more readily because, until we treat of sorites, *combination* is of two. We have seen, in the appendix to my second paper, how the logician, when he has a copula which does not give *his* syllogism, though it be transitive and convertible, has no resource except the combination of relation, thrown into a syllogism of *principium* and *exemplum*. Every thing depends upon our having words descriptive of second intentions, or *schetical* words, which shall, so far as may be, have the force we want in common usage. Four sets are wanted, for terminal precision and terminal ambiguity, both in the mathematical and metaphysical views. Tables of the terms which I adopt for the present, and on which I invite suggestion, are given in the second part. I shall now proceed to some description and remark.

1. *Terminal ambiguity, mathematical view.* Naming the universal first, and its contrary particular second, I say that X is either *species* or *exient* of Y; either *genus* or *deficient*; either *coexternal* or *copartient*; either *complement* or *coinadequate*. When class is treated as a philosophical unit, we have seen that the distinction of the universal and particular proposition is an emergence from that of assertion or denial of inclusion, or of exclusion. But it consists better with the actual form of thought, as trained by existing logic, not to fashion the terms upon the more philosophical basis. To make them stand on the idea of universal and particular I found impracticable: I have therefore taken them upon no basis at all except the aptness of the several words themselves.

Genus and species. I use these words under terminal ambiguity: thus the species may be the whole genus. They have acquired much of this force in common language, by the *subsidence of knowledge*. In old time it was necessary that *man* should not be a species of *rational animal*, but the whole genus: the earth was the only abiding place of animals. But since it has come into thought that animals may possibly reside in stars and planets, it is in thought that man may be no more than a species of the genus. Other planets may contain organised, sentient, &c. bodies which have a thinking faculty and which name, abstract, &c. but in which the whole combination is so different from our own, that we should not call the compound a man. A snake's body, for instance, with a man's mind. The subsidence, or possible subsidence, of genus into species, and the erection of species into genus, by alteration of knowledge or opinion, leave the terms very nearly indeed, if not quite, in possession of terminal ambiguity.

Exient and deficient. I have been obliged to coin the first word, of which the only fault is that it is an *active* participle. *Emergent* is wanted to describe the character of results; *extravagant* and *transcendent* have their derived meanings. *Deficient* usually applies to that

which is all used, but all is not enough: there is no word which signifies a deficiency arising, it may be, from a sufficiency being bestowed elsewhere. In the language I use, X is a deficient of Y, if there be any part of Y which is not X.

On *coexternal* and *copartient*, I need say nothing. The word *complement* means either *contrary*, or *supercontrary* (containing all the *contrary* and also *copartient*).

As to *coadequate*, I may observe that if the earlier logicians had studied the relations of exclusion with any amount of sustained attention, we should have been provided with names to express many relations which are perhaps not so much, certainly not so clearly, in thought as they ought to be, chiefly for want of names. The notion of combination is confined to what is positive: things may conspire to produce, cause, be sufficient, &c., but they do not, in usual idiom, conspire to be insufficient. When it is denied that the contraries of X and Y are coexclusive of each other, so that some things are neither Xs nor Ys, that is, X and Y do not together fill the universe, we see that they are not together adequate, conspire to be inadequate, are *coadequate*. This may introduce the word, but it was not of my making, nor formed by such a deduction. I asked a friend who was likely to give an answer, What, supposing A and B to be areas not together large enough to make C, he would say A and B were to one another in reference to this joint insufficiency: his almost immediate answer was, *Coadequate*.

2. *Terminal ambiguity, metaphysical view.* Not being here restricted by usage but, on the contrary, supported by common idiom, I make the distinction of universal and particular to be merely that of assertion and denial of completeness. Accordingly, X is either an *essential* or an *inessential* of Y; either a *dependent* or an *independent*; either a *repugnant* or an *irrepugnant*; either an *alternative* or an *inalternative*. The four last words may have the sign of convertible relation, *Co-*, prefixed when wanted.

Essential and Dependent. Compare these words with *genus and species*, and the habits of thought of the world at large are well illustrated. The common substantive is of the mathematical type; the common adjective of the metaphysical. The common proposition being physical, the world has a good hold on the substantive *species* and the adjective *essential*: but it knows much less of the substantive *genus*, or of the adjective *dependent*, as here used. Nevertheless, the word *dependent* is common enough: as in, Cleanliness is essential to comfort; comfort depends upon cleanliness. The logician has only the abacus, 'All comfortable is clean.' On the remaining words there is no especial remark to make, except the one which this very dismissal suggests: namely, that it is easy to pick out of common usage a moderately good set of logico-metaphysical words of relation, while as good a set of logico-mathematical words does not exist in the common dictionary. I believe that this phenomenon does not give much countenance to common logic as an exponent of actual thought, though it bears testimony to the science as, in one particular, an improver of it.

3. *Terminal precision, mathematical view.* The phrases used are those which are found in my *Formal Logic*: and need no especial remark here. The only addition is the distinction of extension and intension: thus the subidentical in extension is the superidentical in intension, &c. This distinction is so easily made that I have not thought it worth while to tabulate it.

4. *Terminal precision, metaphysical view.* All the schetical words yet used might be called *predicables*: but it will be historically more convenient to confine that name to the set now before us. I gave them in the *Philological Transactions*, Vol. vi. No. 129 (1853). The predicables of Aristotle savour strongly of the metaphysical view. I here use the adjectives *generic* and *specific*, which, being adjectives, have retained a metaphysical use, and that even with reinforcement. In treating exclusion as well as inclusion, in a definite universe, and with terminal precision, we require three substantive ideas, all attributive, or denoting *attributes*, though that word is technically applied only to one. There is the *attribute*, said of all; the *accident*, of some and some only (which is therefore *non-accident* as to what it cannot be said of, the term being equally positive and negative); and the *excludent*, or *excluse*, said of none. Each of these exists in a three-fold distinction; *universal, generic, and specific*.

Looking at the notion predicated of, say X, in extension, a *universal* predicable is one which applies in the same manner both to X and to x, attribute of both, accident (=non-accident) of both, excludent of both. These are of no value in syllogism. The universal attribute and universal excludent are helps to definition, positive or negative, of the universe: the universal accident, which is independent, inessential, irrepugnant, and inalterative, to both X and x, is what we should suppose of an attribute taken at hazard, with reference to a notion taken at hazard. A predicable is *generic*, when it applies to wider genera of the subject notion, in all the additional extent of those genera: it is *specific*, when it does not apply to any wider genera, nor gain any new extent of application from the additional extent of the wider genus. Here the subject notion has been treated as a class, or the proposition has been made logico-physical: it will be nearly as easy to treat the subject as an attribute, as well as the predicate.

XVIII. On the various names which one relation receives, the following remarks may be made. Since every reading in one view has its reading in the other, the mathematical names will so often and so easily pass into the metaphysical, and *vice versa*, that it is almost as if we gave all the schetical words of either reading to both. To put different, but concomitant, notions under *one name* is clearness, or at least facility, at the beginning of a subject: but the more progress the more confusion, unless it be prevented by checking development. To put them under *different names* is confusion, or at least difficulty, at the commencement: but the more progress, the more clearness, and development without confusion. The question which it concerns me to answer, as to the number of names, goodness apart, is but this:—Have I made any divisions in language which are not divisions in thought? If the answer be in the negative, there is an end of all objection. If logic must take account of *n* real dichotomies, there may be 2^n desirable distinctions to draw: in fact, 1, 2, 4, 8, &c. is the logician's progression, rather than 1, 2, 3, 4, &c.

The want of a distinct name for a distinct notion may affect the mode of thought, must affect the mode of expression, of educated men. Shortly after I had first distinguished by name the *supercontrary* from the *contrary*, I happened to look at several pieces of controversial theology, written by Oxonians versed in the common logic and distinguished by the name of *Tractarians*. Their *universe* was the Anglo-Irish Christian world, consisting of *churchmen* and *heretics*, variously named. I was amused by the frequent protection from difficulty which

I received from my own nomenclature: for the distinction of contrary and supercontrary was either indistinctly conceived by the writers, or, which is more likely, their habits of phraseology had been fashioned in youth upon a logical discipline which did not bring out the distinction in its living force, so that their words were not separatively adequate to their thoughts. Accordingly, though *churchman* and *heretic*, or the synonymes, were clearly meant for supercontrary terms, that is, every man in their universe was one or the other, and *some* (I think it was *many*) were *both*, yet sometimes the words had the contrary, and sometimes the supercontrary, sense, in a manner which would have perplexed a person incognisant of the source of confusion. The comparison of one couple of pages seemed to give the right to infer 'Some churchmen are dissenters:' while another couple seemed to allow us to conclude that *orthodox* and *heretic* are not repugnant attributes.

In connexion with the supercontrary relation, I have the following words:—*Mathematical*, Extensively supercontrary, intensively subcontrary, copartient complement; *Metaphysical*, Intensively subcontrary, generic accident, specific non-accident, irrepugnant alternative. Now I observe that when a compound name exists, the blame of its existence, if any, must be thrown upon the components. If the relations of terminal ambiguity may have names, I cannot choose but call the supercontrary a *copartient complement*, because it *is** *so*. This disposes of the apparent superfluity of names. And we thus draw attention to some much-wanted distinctions. The common word alternative frequently means 'one or the other or both' and more frequently 'one or the other but not both.' There is no word in common use to mark the distinction; nor have educated logicians yet introduced the distinction of repugnant alternative and irrepugnant alternative.

XIX. By accustoming the mind to the combination of relations, under the clearness of well-understood language, we dispense with the logician's abacus, even in the most complicated cases. For example, take the following syllogism: 'We must not say that either bodily strength or meanness is a necessary alternative, for courage and meanness are incompatible, while courage does not depend on bodily strength.' Compare it with the following: 'Health is essential to comfort and comfort to full use of the faculties, whence health is essential to full use of the faculties.' The second is a very obvious consequence, while the first, as given, is either a very dark one, or a *non sequitur* of mine, as a trap. Will the reader say which, honestly, without going to the abacus? A full and clear notion, such as practice only gives, of the meanings of alternance, repugnance, and dependence, would answer the question of itself.

The educated world, though not so far advanced in combination of relation as it would be under instruction in the logic of second intentions, has made far too much progress to need the abacus as a means of power, in usual cases; accordingly, it laughs at the abacus and those who use it. It does not value the instrument as an analyser, because it derives no power from the analysis, as commonly made. In like manner, one who could perform division in his head,

* The honest sailor's mistake is no mistake at all about composition of names to which meaning has been previously attached. He scomed the French for calling a cabbage a shoe (*chou*): why, said he, can't they call it a cabbage, when they must know it *is* one? A word with a meaning to it is a

thing, or has the privileges of a thing; one of which is a right to combine whenever combination can be. Hence when the names A and B have been attached to meanings, the only question about the introduction of AB is, does the compound exist or not?

when the divisor does not exceed 10, would look down on a *calculator*, a user of pebbles on all occasions, in spite of the manner in which the pebbles would assist fundamental explanations. This is no proof of wisdom: but we may as well wait to teach a boy his letters until he can read his way to school by the corners of the streets as expect to teach the world on a basis which requires it to have philosophical acuteness before it can make up its mind to want the teaching. The mathematics made their modern way, not as the philosophy of space, time, and number, but as the instrument of surveying, navigation, commerce, &c.: and in this day, more than ever, they have a crowd* of followers who have no idea of any other use. Let logic be taught so as to sharpen the intellect as well as to analyse its processes, and logic will thrive as much as mathematics: while the abacus will become, as it ought to be, the starting-point of little boys and girls, instead of being at the top of a column of psychology.

XX. In the metaphysical words of relation we have seen that *necessity* is of the purely logical form, as explained. But all reference to causation must be absolutely thrown away from each relation. This is not merely a logical demand: even the *material* meaning of the words ought to be independent of causation. Thus, health and intemperance are repugnant. We do not mean that intemperance is *the* cause of ill-health, or even *one* cause: we may know this, but the proposition in hand does not state it; and in fact, ill health frequently leads to intemperance, not the converse. Another form is, temperance is an essential of health: not a cause, there may be temperance without health; ill health often leads to temperance. Another equivalent is, health is dependent on temperance; but not on temperance alone. Lastly, ill health and temperance are alternatives, but not *repugnant* alternatives. This branch of logic would help to drive out the idea of causation which lurks in that of connexion. In the logical form, necessary and sufficient cause is dependent (in the form of thought) upon its effect, as well as effect upon cause: effect is essential to cause, as well as cause to effect. If the attributes gravity and weight be never separate either from the other, they are *logico-metaphysically* identical, and each is an *essential dependent* of the other. When our reputed *cause and effect* are not precedent and consequent, but strictly simultaneous, a question arises whether these words be rightly applied. Their real sense may be of a much more subjective character than physical philosophers take them in. Force and change of momentum are always simultaneous: our predetermination to employ force is only in consciousness: we say that change of momentum will follow; but the two things go together, and in fact we change one momentum in producing what we call the force which changes another momentum. Would higher knowledge teach us to say that change of momentum evolves force, not *vice versa*?

* There is a strong impression in the world of physical inquiry that a mathematician is almost bound, whatever his pursuit may be, to make his science the means of investigating or registering some facts connected with the material world. A *teacher* of mathematics for example, whose business it is to study the mind and its discipline, that he may make his teaching permanently useful to those who will not, in nineteen cases out of twenty, ever have any need to apply it professionally, would be thought quite in the right way if he should take to

investigating the force of steam, or the strength of beams, or the orbits of binary stars: they would call him a *practical man*. I should give him quite another name if he took up steam or star for anything beyond relaxation, supposing his taste to turn that way. The disposition to hold material application to be *always* practical is one of the consequences of the want of psychological thought, and will vanish before sound logical training, with other myopias.

This is one of those questions which it is very important to ask because they cannot be answered. We ought however to think it *possible* that we have made a converse to the Irishman's blunder,

For though one went *before* and the other *behind*, Sir,

They set off *cheek by jowl* at the very same time, Sir.

XXI. I have had much occasion to point out that the logician is, by his own choice, no more* than a mathematician: not too mathematical, in fact not mathematician enough, if he will be nothing more. One error forces a metaphysical notion within the mathematical boundary, as a concept the *sum* of all its attributes. One is the presentation of a mere transformation—'Some animal is all man' from 'All man is some animal'—as transition from the mathematical to the metaphysical. One grand error† yet remains, though not, I judge, so widely received. Before proceeding to it I remark that the logician, in thus making mathematics a present of his science, does it under protest that the mathematician is not to plant it, and make it grow: above all, that he is not to use any symbol-manure. Those who make a concept the *sum* of its attributes are indignant at the appearance of $A + B$: though, had they had a mathematician's power over the distinction of $A + B$ and AB , they would never have fallen into the mistake.

The attachment to mathematical quantity has become so strong that this Aaron's rod has swallowed up all the others. We are told that predication is nothing *more or less* than the expression of the *relation of quantity* in which notions stand to one another; that we think *only* under determinate quantity; that *all* thought is comparison of *less and more* (*Achilles killed Hector*, for example); that an affirmative proposition is *merely* an *equation of the quantities* of its subject and predicate, and the *consequent* declaration of the coalescence of terms in a single notion; that a negative proposition is a *non-equation*—whatever that may mean—of quantities, and an announcement of non-identity of terms. The word *equation* is often followed by *identification*, in a manner which would lead us to suppose that the two words are taken as convertible.

Quantity, to confront the old logicians with the new ones, was left undefined by Aristotle for several reasons: the first, that it is a *summum genus*, and therefore cannot be defined; we may excuse them all the rest. The followers gave various definitions, one of which would palliate the preceding use of the word *equation*: it is *res per se divisibilis in partes*, which confounds quantity with its subject of inhesion. Others, passing to another extreme, made *quantitas* the abstract notion on which we say of anything that it is or has *quantum*: and

* From the thesis that the mathematics contain a sufficient study of logic, and the answers which have been made to it, I equally dissent. But the discussion would require a volume. Every branch of learning certainly grows a crop of logical habits, that is, of habits of the form of thought: a majority good, a minority bad. Nothing but the study of logic as a science, simultaneously with other studies, will prevent tares from growing up with the wheat.

† I might dwell on some strange uses of mathematical language: but there is only one which really makes a difficulty; it is the use of the word *numerical*. Many writers on logic call the distinction between one thing and another—their

not being the same thing—a *numerical* distinction. Thus they say that a perception is numerically different from the thing perceived; and that the hunger of to-day is numerically different from the hunger of yesterday. Now though it may be true that first, second, third, &c. are called by grammarians ordinal *numbers*, it is equally true that the phrase will not stand the smallest reflexion. The seventh, the twentieth, are not numbers: the distinctions are ordinal, because they are arranged in order; but they are not numerical distinctions; they do not allow predication of more and less. The ordinal numbers, so called, are of a pronominal character: this, that, the other, supply the place of the first three.

thus they announced a maxim which bewilders those who have not the key; *Quantitas non suscipit magis et minus.*

They meant that a thing which has one amount of *quantum* is not a thing of which we have more perception of its having *quantitas* than another thing of another amount of *quantum*. Nevertheless, even in the hands of the old logicians, quantity came to have the meaning which we now* give it, that which exists where it is possible to conceive of answer to the question How much? or How many?—measured solely by the *quantum* of the answer. Accordingly, to *equate* two quantities, is to assert them to be the same quantities: a furlong of the wall of China is the same quantity of length as 220 yards of the pier at Brighton. The *res divisibilis* is a frequent use of the word in common life. Thus a person may buy a *quantity* of timber, and may sell that *quantity* again, meaning the very same planks, not as many cubic feet out of what he had before. To *equate* quantities, even if the word be thus restricted, can only mean to *identify* them in a very loose and inaccurate acceptation. If a person should be tried for stealing the timber just spoken of, his counsel could not properly ask the prosecutor, even when speaking concretely of quantity, ‘Now, Sir, on your oath, can you equate the quantity found on the prisoner’s premises to the quantity you bought at the yard?’

The singular theory of predication above described seems to depend, not merely on the adoption of the *res divisibilis* by persons unpractised in mathematical thought, though this must have had some share; but also on a tendency, fostered by an invented quantification, to confusion between two attributes of the relation of *whole and part*; one, the notion of *containing and contained*, the other, the notion of *more and less*. *Containing and contained* is convertible with *whole and part*, if terminal ambiguity be conceded to both, or denied to both: but *more and less*, though contained in either on the same terms, is not convertible with either. The mathematicians, to whom *more and less* frequently constitutes the whole matter of thought for which they introduce the relation of whole and part, do very often use the name of the whole relation for the name of the component which they are considering: thus a problem may occur in which a bottle of sherry in London in 1857 may be (quantitatively only) part of a cask of claret at Bordeaux in 1800. The mathematicians thus speak of the compound where they mean only the component: the logicians whom I am now describing insist that the compound shall mean no more than the component.

* The mathematician becomes so accustomed to the abstract *quantitas* that he often forgets—and some have even denied—the quantitative science of the *res divisibilis* itself. This science, to which the curious in words may refuse the name of arithmetic in its *addition or subtraction*, until *concrete number* is expressly introduced, becomes arithmetic in its *multiplication* and even takes from abstract arithmetic: for the multiplier must be an abstract number. In its *division*, either magnitude divided by magnitude gives an abstract quotient, or magnitude divided by abstract number gives a magnitude as quotient. So that, granting application of magnitude to magnitude, addition and subtraction may be treated independently of any notion of number, and number itself may be *learnt* in the quotient of division, made antecedent to multiplication. When we come to fractions in abstract arithmetic, which we cannot do without

making an abstract *res divisibilis* of the unit, we see a cognate distinction. Addition, subtraction, and division with integer quotient can be fully conceived and reduced to rule so soon as the common denominator is obtained, or the modes of dividing the unit all reduced to one: multiplication remains inconceivable until the idea of *part of a time* is introduced.

Euclid’s system of proportion is a specimen of the arithmetic of the *res divisibilis*. When it is abandoned, and what is called an *arithmetical* definition is introduced, elementary writers generally leap the difficulty of expressing magnitudes numerically, and start from the expressed magnitudes, taken merely as numbers. But the way of bridging this chasm involves some matters which are of great importance. The connexion of number and magnitude should not be left to mother-wit.

There is no use* in the arithmetically definite syllogism: to this there is almost unanimous agreement. But the study of it would have prevented such mistakes as that on which I am now writing. For it is an exercise in the study of the relations of quantity as part, *and part only*, of the study of the coalescence and non-coalescence of notions. It shows that quantification of the predicate is a superfluity, an excrescence which disappears in the elaboration of rules of inference: and that the only entrance of comparison of quantity into negatives is through the limitation of the universe by which those negatives are but other affirmatives.

I now proceed to the second part of this paper, the first elements of the system on which the preceding remarks are made. Some part of the groundwork of its higher developments is contained in my second paper.

SECTION 2. *First Elements of a System of Logic.*

XXII. A *name* is a sign by which we distinguish one object, process, or product of thought from another.

A name has four applications: two *objective*, signs of what the mind can (be it right or wrong in so doing) conceive to exist though thought were annihilated; two *subjective*, signs of what the mind cannot but conceive to be annihilated with thought. (§ VI.)

The objective applications are:—first, to individual *objects* external to the mind; secondly, to individual notions attaching to or connected with objects, called *qualities*, which are said *and thought* to inhere in the objects. The object itself is but a compound of qualities. The *quality* is, in logic, any appurtenance whatever: thus to be called Cæsar is a quality.

The subjective applications are:—to designate *class*, collection of objects having similar qualities, or put into one notion by some similar *class-mark*; and a class may consist of one individual only, if only one have the mark: secondly, to designate *attribute*, the class-name of *quality*, the notion of quality in the mind.

Class and *attribute* are two modes of thinking many in the manner of one; two reductions of plurality to unity. The class *man* is one notion in the mind, the receptacle of many individuals: the attribute *human* is also one in thought, being the notion derived from similar qualities possessed by many individuals. *Class* is a noun of multitude, but not a multitude of nouns, nor even one noun selected from a multitude.

Quality, as a class name, may be distributed over any number of individuals. But it has a division peculiar to itself. As merely an appurtenant notion, it may be the compound of several notions. And similarly, attribute may be the compound of several attributes.

In grammar, class is often a substantive capable of designating the individual also, and used in both ways, as *man*, the man Plato. Quality is often an adjective, as *human*; attribute is often an abstract substantive, as *humanity*, which cannot designate an individual.

* It is, I find, at the utmost, worth doing once or more as a school-exercise. This is exactly the view I take, and have always taken, of all that I now call the *arithmetical* whole of logic, including the common form of syllogism. Nineteen years ago I wrote my *First notions of Logic*, intended, as the preface states, ultimately to become an appendix to my

Arithmetic. I had not then any glimpse, so far as my memory serves, of the numerical syllogism: and I doubt if I could have given any very distinct account of my reason for appending the common syllogism to a book of numbers. But it may be that my now confirmed notion of the usual form of syllogism being arithmetical was germinating.

Language would be more perfect if these distinctions were made by inflexion in all cases: logic would do well to think of introducing such* words as X-ic and X-ity.

The class is an aggregate of individuals; the individual is a compound of qualities; the attribute is a compound of attributes.

Objective names, representing objects and qualities, were once called names of *first intention* or *first notions*, as being used according to the mind's first bent towards names. Subjective names, representing classes and attributes, were names of *second intention*, or *second notions*. Thus, 'every crow is black' considered merely as a collation of cases, is of first intention: but 'the class crow has the attribute black' is of second intention. Nevertheless, the first sentence, spoken or written, may be thought under the second form. (§ XII.)

Logic is the science and art, the theory and practice, of the form of thought, the law of its action, the working of its machinery; independently of the matter thought on. It considers different kinds of matter only when, if ever, and so far as, they necessitate different forms of thought. It must deal with names, and therefore should deal with all the forms of thought demanded in the four uses of names. It has no right to reject any use of a name: for every such use appertains to a form of thought. (§§ II, III.)

Logic considers both first and second intentions, because both are forms of thought; but the first chiefly as leading to the second: and in both it considers *quæ non debentur rebus secundum se, sed secundum esse quod habent in anima*. That is, logic belongs to psychology, not to metaphysics.

It is not to be assumed that the practice of the logic of first intentions is the common property of mankind, and that second intentions form a science to which the student is to be led. The actual form of thought is an unanalysed mixture of first and second intention, with the latter in decided predominance.

A name may be formed from other names as follows. First, by *extension*, symbolised in $X = (A, B, C)$ where the *aggregate* X includes as much as can be spoken of under each and all of the *aggregants* A, B, C. Secondly, by *intension*, symbolised in $X = A-B-C$, or ABC, where the *compound* X includes *no more than* can be spoken of under *all* the *component* names A, B, C. Thirdly, by combinations of the two.

Increase of extension is generally diminution of intension, never increase: and diminution of extension is generally increase of intension, never diminution. And *vice versa*.

The disjunctive particle, *or*, expresses aggregation: 'either A or B' means 'in the class (A, B).'

Class is most connected with extension, and attribute with intension. Extended attribute is merely class of qualities, and there is some effective use in the distinction between class and its subdivisions on the one hand, and the whole class-mark and its subdivision into qualities on the other hand. These two forms of thought, though closely related, must not be confounded with the relations arising out of comparison of extension and intension. (§ VIII.)

* The boldest symbolic word ever made was proposed—I think in print, but I cannot find the reference and I am not sure—by one of the young analysts (I speak of 1813, or thereabouts) who first cultivated the continental analysis in England.

It was such as 'iso-*x*-ical,' to signify that in which *x* has always one value. Thus every circle which has its centre at the origin is iso- $(x^2 + y^2)$ -ical. When the crude form is not too complicated, the word might be useful.

Aggregation of the impossible does not destroy the notion; composition of the impossible does. (§ X.)

The universe is the whole sphere of thought within which the matter in hand is contained: usually not the whole possible universe of thought, but a limited portion of it. In the last syllogism of § IV, the universe is *speed of transmission of news*. The universe being U, the class X introduces with itself the class not-X (or x). Let X and x be called *contraries* or *contradictories* (I make no distinction between these words). It is understood that every class is only *part* of the universe. The symbol (X, x) is equivalent to U: in extension, it contains everything; in intension, it belongs to everything. Thus A, if in the universe, is in (X, x); and A is A-(X, x), aggregate of A-X and A-x. The universe is the maximum of extension, and the minimum of intension. (§ IX.)

The contrary of an aggregate is the compound of the contraries of the aggregants: the contrary of a compound is the aggregate of the contraries of the components. Thus (A, B) and AB have ab and (a, b) for contraries.

XXIII. When two objects, qualities, classes, or attributes, viewed together by the mind, are seen under some connexion, that connexion is called a *relation*. To make very perfect parallelism, we should say that *relation* may be either of the four: that a boat towed by a ship, for instance, has the tow-rope for an *object* of relation. But relation, for all useful logical purposes, is a word of second intention, used only of class and attribute.

A *proposition* is the presentation of two names under a relation. A *judgment* is the sentence of the mind upon a proposition, true, false, more or less probable. The distinction of judgments, other than the simple *true* or *false*, is referred to the theory of probabilities, as a matter of practical convenience. The absolute exclusion of this distinction from logic is an error: the difference between certainty and uncertainty is of the form of thought; the amount of uncertainty is of the matter of this form. Full belief is a logical whole, which is divided into parts in the theory of probabilities: and the division of a logical whole into parts is of logic, whether it be convenient or not to treat it in the same book which treats the syllogism.

The distinction of *subject* and *predicate* is the distinction between the *notion in relation* and the *notion to which it is in relation*.

Every relation has its counter-relation, or *converse* relation: thus if X be in the relation A to Y, Y is therefore in some relation B to X: and A and B are converse relations, and the propositions are converse propositions. Every proposition has its converse, of meaning identical with itself.

When a relation is its own converse, the *proposition* is said to be *convertible*: meaning that the converse exhibits no change of relation. It is the *terms* (subject and predicate) which are convertible, strictly speaking.

When X has a relation (A) to that which has a relation (B) to Y, X has to Y a *combined* relation: the *combinants* are A and B. Relations have both extension and intension. Thus, to take one of those *relations* which have appropriated the word in common life, the relation of *first-cousin* is the *aggregate* of son of uncle, daughter of uncle, son of aunt, daughter of aunt. The relation of the minister to the crown is the *compound* of *subordinate* and *adviser*.

XXIV. Certain relations take precedence of all others, because they are presented by the notion of naming, and spring out of its purpose, if indeed they do not themselves constitute the purpose. They may be called *onomatic* or *onymatic* (*nominative* and *nominal* being engaged).

The excessive importance of these relations has enabled them to drive all others out of common logic, on the pretext of every other relation being expressible in terms of these: as must be the case, since these relations exist wherever names exist which apply to the same object.

The onymatic relations, to which in *this* paper I confine myself, are those of *whole and part* in the two aspects of *containing and contained* and *compounded and component*; and also the relations which the notion of contraries, and the notion of true and false, introduce in connexion with them.

Subordinate to, and necessarily compounded in, the notion of whole and part, is that of *more and less*, in the matter of which are the incidents of *quantity*. But *more and less* is only a component of *whole and part*, in the form of thought: and except as such component, is of no logical import. Thus *infusorium* is no doubt a larger class than *man*, and no doubt for reasons: but if we knew the extent of superiority, and the reasons, neither would be of any logical effect, for our present purpose; because the more and less is not that of containing and contained, and the relation is not onymatic.

The distinction of *aggregation* and *composition* is the most important distinction in the subdivisions of logic. Our knowledge does not suffice to define it by full description: we can only illustrate it. To the mathematician we may say that it has the distinctive character of $a + b$ and ab : to the chemist*, of mechanical mixture and chemical combination: to the lawyer it appears in the distinction between 'And be it further enacted' and 'provided always.'

XXV. The notion of whole and part presents itself in three different ways, giving rise to three *logical wholes*.

Arithmetical whole. The class as an aggregate of individuals; the attribute as an aggregate of qualities of individuals. This whole is objective, of first intention, enumerative of individuals in process, collative of individuals in result. It *numbers*, whether the numerical result be definite or vague; and always either answers the question *How many?* or permits that question as a pertinent supplement. As in, 200 men were on board the packet, Every man is animal, Some men are learned, Some men are not some men, &c. Inductive verification is conducted in this whole, which is subordinated to both the other wholes, but in different ways. It is the essential character of this whole that it aggregates *similar things*, things only distinguishable as this, that, and the other, of the same name applied in first intention to all separately. And so it can only be a whole of aggregation. Composition of similars is unmeaning: a human human human being† is only a human being; we cannot subdivide a class by its own name.

The two other wholes are of second intention, subjective in character, enumerative only,

* The chemist will some day be aware of the great mistake he has made in using the sign + to denote chemical combination. † This is Mr Boole's equation $x^2 = x$.

and collative only, upon the ideas of class and attribute considered as philosophical units. They number, then, but the numerical total is of no interest, or only of infrequent and accidental interest, in the form of thought: just as in common life, the junction in thought of a general, a battle, a site, a result, and a despatch, offers no interest in its *quinary* character. The *mathematical* whole, or whole of *class*, thinks, most frequently, of class aggregated of classes; less frequently, rarely in comparison, of class compounded of classes. The *metaphysical* whole, or whole of *attribute*, thinks, almost always, of attribute compounded of attributes: sometimes, but very rarely, of attribute aggregated of attributes. Extension, then, predominates in the mathematical whole; intension in the metaphysical.

Every proposition, at least of the onymatic character, may be thought in either whole: and practical logic slips out of one into the other, as facility will require. All consequences which spring out of onymatic relations may be obtained in any whole. To insist that all thought *is* in one whole, is a mistake: that it *ought* to be, an absurdity.

Each onymatic proposition has two terms, and each term may be thought in either of the two ways. This gives four *readings*:—

		Subject.	Predicate.	Notation.
Logico -	{	Mathematical	Class	Class))
		Physical	Class	Attribute)]
		Metaphysical	Attribute	Attribute)]
		Contraphysical	Attribute	Class)]

On these see § X. I shall here specially consider the first and third, from which all that is peculiar to the second and fourth easily follows.

In the relation of containing and contained, there may be *terminal precision*, or *terminal ambiguity*. If, when X is contained in Y, we mean that X is part only, leaving another part, there is terminal precision; but if we mean that possibly X may be as large as Y, there is terminal ambiguity. The distinction is that of part-not-whole, and part-or-whole. (§ XI.)

The first table following contains the various relations which may exist between the *classes* X and Y, as to inclusion or exclusion, under terminal ambiguity, with the readings in the arithmetical whole, and the notation of my last paper, presently noticed further. This is all condensed in the heading: and the other tables are as described.

XXVI. *Logico-mathematical Reading. Terminal Ambiguity.* (§§ XIII, XVII.)

Proposition of assertion or denial.	X subjected to Y as	Y predicated of X as	Reading in arithmetical whole.	Notation.
Assertion of X contained in Y	Species	Genus	Every X is Y	X))Y
Denial of X contained in Y	Exient	Deficient	Some Xs are not Ys	X(·Y
Assertion of X excluded from Y	Coexternal	Coexternal	No X is Y	X)·Y
Denial of X excluded from Y	Copartient	Copartient	Some Xs are Ys	X()Y
Assertion of x contained in Y	Complement	Complement	Everything is either X or Y	X(·)Y
Denial of x contained in Y	Coinadequate	Coinadequate	Some things are neither Xs nor Ys	X)(Y
Assertion of x excluded from Y	Genus	Species	Some Xs are every Y	X((Y
Denial of x excluded from Y	Deficient	Exient	No Xs are some Ys	X))Y

XXVII. *Logico-mathematical Reading. Terminal Precision, § XI.*

Proposition of Assertion.	X subjected to Y as	Y predicated of X as	Compounded of	Notation.
X and more contained in Y	Subidentical <i>Deficient Species</i>	Superidentical <i>Exient Genus</i>	X))Y, X(·)Y	X)o)Y
X contained in and containing Y	Identical <i>Species Genus</i>	Identical <i>Genus Species</i>	X))Y, X((Y	X Y
X containing Y and more	Superidentical <i>Exient Genus</i>	Subidentical <i>Deficient Species</i>	X((Y, X(·)Y	X(o)Y
X and more contained in y	Subcontrary <i>Coinadequate External</i>	Subcontrary <i>Coinadequate External</i>	X)(Y, X)(Y	X)o(Y
X contained in and containing y	Contrary <i>External Complement</i>	Contrary <i>External Complement</i>	X)(Y, X(·)Y	X · Y
X containing y and more	Supercontrary <i>Copartient Complement</i>	Supercontrary <i>Copartient Complement</i>	X(·)Y, X)(Y	X(o)Y

Here X)o)Y is a compound of X))Y and X)(·)Y, coexisting. We deny it by denying either X))Y or X)(·)Y, or by asserting *either* X(·)Y or X((Y. Let this aggregate be represented by X(,(Y. Then X)o)Y is denied by X(,(Y, X(o)Y by X(·)Y, X)o(Y by Y(·)Y, X(o)Y by X)(·)Y. And identity, X || Y, is denied by either X(·)Y or X)(·)Y; and contrariety, X | · | Y, by either X)(Y or X)(Y. When we read in mathematical intension, the prepositions *sub* and *super* change places.

XXVIII. *Logico-metaphysical Reading. Terminal Ambiguity, § XVII. 2.*

Proposition of Assertion or Denial.	Y predicated of X as	X subjected to Y as	Reading in arithmetical whole (by intension only).	Notation.
Assertion of Y a component of X	Essential	Dependent	Y always in X	X]]Y
Denial of Y a component of X	Inessential	Independent	Y sometimes not in X	X][Y
Assertion of Y incompatible with X	Repugnant	Repugnant	Y never in X	X][Y
Denial of Y incompatible with X	Irrepugnant	Irrepugnant	Y sometimes in X	X]Y
Assertion of Y a component of x	Alternative	Alternative	In everything either X or Y	X[·]Y
Denial of Y a component of x	Inalternative	Inalternative	In some things neither X nor Y	X][Y
Assertion of Y incompatible with x	Dependent	Essential	In Y always X	X[[Y
Denial of Y incompatible with x	Independent	Inessential	In Y sometimes not X	X]]Y

XXIX. *Logico-metaphysical Reading. Terminal Precision, § xvii. 4.*

Proposition of Assertion.	Y predicated of X as	X subjected to Y as	Notation.
Y an attribute of the universe	Universal Attribute <i>Essential Alternative</i>	<i>Dependent Alternative</i>	—
Y and others components of X	Generic Attribute <i>Independent Essential</i>	{ Specific Accident Generic Non-accident <i>Inessential Dependent</i>	X]o]Y
Y component and compound of X	Specific Attribute <i>Dependent Essential</i>	Specific Attribute <i>Dependent Essential</i>	XIIY
Y compound of X and others	{ Specific Accident Generic Non-accident <i>Inessential Dependent</i>	Generic Attribute <i>Independent Essential</i>	X[o]Y
Y neither component nor compound of either X or x	Universal Accident and Non-accident <i>Inessential, Irrepugnant, Inalternative, Independent</i>	Universal Accident and Non-accident <i>Inessential, Irrepugnant, Inalternative, Independent</i>	—
Y and others components of x	{ Generic Accident Specific Non-accident <i>Irrepugnant Alternative</i>	{ Generic Accident Specific Non-accident <i>Irrepugnant Alternative</i>	X[o]Y
Y component and compound of x	Specific Excludent <i>Repugnant Alternative</i>	Specific Excludent <i>Repugnant Alternative</i>	XI·Y
Y compound of x and others	Generic Excludent <i>Inalternative Repugnant</i>	Generic Excludent <i>Inalternative Repugnant</i>	X]o]Y
Y an excludent of the universe	Universal Excludent.	—	—

The words subidentical &c. may also be introduced, in metaphysical sense, referring to intension, from the second table, with inversion of prepositions. Thus X]o] Y means that X is a superidentical of Y, and Y a subidentical of X.

XXX. I shall now proceed to some remarks and developments:—

Arithmetical whole. In the third table, in this reading, X and Y are treated as qualities; and 'Y is always in X' means that the quality Y is always recognised as a component of the quality X. Thus in the more objective side of this whole we read 'Every (object) man is (object) animal:' in the more subjective side we read 'Some (instance of quality) animal is in every (instance of quality) human.' This constitutes the whole of what many writers in this country now accept as the distinction between extension and comprehension: but, as to the distinction which I have called that of extension and *intension*, this distinction is only that of *object* and *quality*, both in extension. See § VIII.

Those who supply complete terms of quantification make a mixture of what I called in my second paper *exemplar* and *cumular* reading; as in 'All X is some Y' and 'No X is any Y.' When it is postulated that propositions shall be formed by every possible distribution of the terms of quantity, *all* and *some*, the two propositions 'All X is all Y' and 'Some X is not some Y' arise. The first is X | | Y of the second table; the other has no place in the propo-

sitions of second intention. I hold by the opinion that the true* way of reading this system into consistency is the *exemplar* method, as explained in my last paper. I insist on it that a set of logical forms in which some propositions enter without possibility of contradiction *within the forms* is wholly inadmissible. For right and wrong, true and false, are the ultimate ends of applied logic; and a system which does not point out the false belonging to every true case, and the true case belonging to every false one, may defend itself, if it like, by saying that the difference between truth and falsehood is *material*: but one would almost suppose it held that difference to be *immaterial*.

XXXI. *Relation of the two precisions.* The precise proposition is a compound of two ambiguous ones: the ambiguous proposition is an aggregate of two precise ones. The sub-identical is both species and deficient; the species is either subidentical or identical. Either may be made a simple act of the form of thought: but, with reference† to the other, either is complex.

Any digested system of propositional forms which gives a mixture of precise and ambiguous forms offends against all sound classification. Even if habit of thought should use such a system, this only proves that thought should be instructed to use the whole of both systems, instead of throwing away some of each, and joining the rest into a hybrid.

XXXII. *Extreme cases.* The table of terminal precision joins two ordinary propositions together, in every useful case. What do the other cases mean? First, $X \supset Y$ and $X \cdot (Y \cdot X)$ express the utmost contradiction possible. But it is to this effect: X does not exist in the universe. For $X \supset Y$ is a reading of $X \cdot (y, \text{ which with } X) \cdot (Y, \text{ excludes } X \text{ altogether.}$ This answers to the way in which a mathematician examines a symbolic impossibility, and finds

* There is another, to which I was led by a passage in a review of my last paper. It was advanced that the contradiction of 'All X is all Y' is 'All X is not all Y': which, if the second form be properly understood, is correct. Why then was this not introduced among the forms? Perhaps because there would then have been two negatives with both terms universal: one 'All X is not all Y'; the other 'Any X is not any Y'. And having thus introduced 'all' into the negatives, the following, 'Some X is not all Y', must have been examined. This should contradict 'Some X is all Y' or 'All Y is X'. So that 'Some X is not all Y' should have 'Some Y is not any X' for its equivalent. This is correct. And the principle of demanding contradiction introduces 'Any X is any Y' as the contradiction of 'Some X is not some Y': and *any*, thus introduced among the affirmatives, must be carried through. Let this be done, and there are three quantifiers; *all* (unbroken collection), *any*, and *some*. The chain of propositions and their contradictories does exist: and it is as follows. The bracketted propositions are equivalents:

<p>Affirmative Proposition.</p> <p>Any X is any Y } Any X is all Y } All X is any Y }</p> <p>Any X is some Y } All X is some Y }</p> <p>Some X is any Y } Some X is all Y }</p>	<p>Contradicting Negative.</p> <p>{ Some X is not some Y { Any X is not all Y { All X is not any Y</p> <p>{ Some X is not any Y { All X is not some Y</p> <p>{ Any X is not some Y { Some X is not all Y</p>
---	--

<p>All X is all Y Some X is some Y</p>	<p>All X is not all Y Any X is not any Y.</p>
---	--

This is the complete system of quantification by postulation, when it is open to entrance of cumular terms and bound to exhibition of contradictories. In affirmatives, *all* is *any* when it occurs only once; and *any* is *all*. When *any* occurs twice, either or both give *all*: for '*all* is *all*' follows from '*any* is *any*,' though not the converse. In contradiction, the occurrence of *all* has the effect of an individual term: when either P or Q is individual, 'P is Q' and 'P is not Q' are contradictions. When *all* is absent, *any* is changed into *some*, and some into *any*.

† This duality will surprise the logician, but not the geometer. A point determined by planes is a complex notion, the common intersection, or sole point determined, by three planes. But so is a plane determined by points: three points determine one plane. The cultivators of geometry know this law of *duality*, with its marvellous consequences: the logician has yet to study it as a law of thought. But there are false dualities, as well as true ones. A circle which rolls upon another may be looked at as in simple motion: and will be so looked at by many, especially by those accustomed to the turning of trochoidal lines. But geometry knows that the rolling circle has a twofold rotation. The difficulty which so many have found in the moon's rotation depends upon this conversion of duality into unity, which compels them to consider unity as duality. We cannot allow water to be a simple substance, without declaring oxygen a compound.

out the species of impossibility which it belongs to. Again, $X \supset Y$ and $X \cdot Y$, incompatible when X is part of the universe, become compatible when X and Y are coextensive with the universe. Again, $(\)$, (\cdot) , (\cdot) , may all coexist. Any other junctions give only parts of the propositions we already have. The three junctions noted answer to the *universal* predicables in the fourth table, which are introduced to give completeness of language: the correspondents of the second table are hardly worth setting down. For the explanation of the terms of the fourth table see § XVII. 4.

XXXIII. *Affirmative and negative propositions.* With me these are technical terms, not wholly corresponding to *assertion* and *denial*. A proposition is affirmative which is always true of identicals and false of contraries: a proposition is negative which is always false of identicals and true of contraries. Thus \supset , (\cdot) , (\cdot) , are affirmatives; \cdot , (\cdot) , (\cdot) , are negatives: the inserted dot indicates a negative; if an express symbol be required for an affirmative, it may be two dots, or $\supset\supset$ may be $\cdot\cdot$. We see that $X \cdot Y$ is negative, though in common* language, it is an assertion, 'Every thing is either X or Y .' But it has the *properties* of the other negatives.

XXXIV. Previously to entering upon the subject of *quantity* the following considerations are conveniently inserted here.

Proof of a proposition is the acquisition of necessary assent: and it must consist in ascertaining, first, that the names are rightly applied, secondly, that the relation between them is truly stated.

Inductive proof, or *induction*, or proof *à posteriori*, is the *aggregation* of separate verifications, whether upon individual qualities or objects, or species or component attributes, in number enough to make assent to the proposition an unavoidable necessity of thought.

Deductive proof, or *deduction*, or proof *à priori*, is the *composition* of separate previous propositions, from which the same unavoidable necessity follows.

The name depends upon the *immediate* character. Thus a deductive proof may have its components, or some of them, furnished by separate inductions, or may be a compound of inductions; and an inductive proof may be an aggregate of deductions. For instance, as often occurs in mathematics, an inductive proof may have every aggregant a compound of deduction from all those which precede.

Probable or *physical* induction is where the number of cases verified is so large, without any failure, that the mind feels the sort of necessity called *moral certainty* that no failure ever can occur within any limited experience. Where or why this proof is wanted, we are not to inquire: it is enough that this kind of proof is one of the forms of thought. All these cases come under the word *proof* in logic, because, under all these cases, the mind works with and from the proposition in one and the same way: be it with more of certainty, or less; with one ground of certainty, or another.

* The disjunctive form in which the proposition (\cdot) is most clearly enunciated, that is, 'Everything is either X or Y ,' instead of 'No not- X is not- Y '—has been made the occasion of an assertion that I, in ignorance, introduce disjunctive syllogisms among categorical ones. This I do, beyond doubt: for, in adopting categorical syllogisms, I cannot avoid adopting

disjunctive ones. Contraries once allowed, every categorical syllogism is also disjunctive. Thus the old instance, 'Every man is animal; *Sortes* (so Socrates was at last written) is man; therefore *Sortes* is animal,' can be identified with the following: 'Every thing is either animal, or not-man; *Sortes* is not not-man; therefore *Sortes* is animal.'

When a proposition proves of *all*, let it be called *necessary*. Logical necessity does not distinguish the preceding cases from one another. When a proposition proves of *some only*, not all, or not known to be all, it is *contingent*.

Inference differs from *proof* in having reference only to the perception of the purely logical part, the validity of the mode of junction of the propositions, or of the combination into one of the relations they propound.

XXXV. In verification of names, we must imagine what I may call *registers*. One register answers, in every case, the question whether this or that object, species, attribute, is within the universe. This register is used in ordinary logic: existence is supposed to be ascertained before use of a name; and *all existence* is the universe of the propositions. I substitute existence in a given sphere of thought. Another register points out, for each name, the cases in which that name applies, and in which its contrary.

A proposition is *universal*, when inductive verification requires the examination of every part of extension of the universe (the maximum of extension and minimum of intension) or of every augmentation of intension which takes place within it: otherwise, the proposition is *particular*. A proposition is universal both extensively and intensively, or both ways particular. The universals are \forall , (\exists) , (\cdot) ; the particulars are (\exists) , (\cdot) , (\cdot) .

Keeping within the universe, by hypothesis, we cannot go beyond a certain extension, or below a certain intension: we never decompose the intension of the whole universe, or treat its intension as a compound; we never add to the whole universe, or make its extension an aggregant. Hence it is that extensively and intensively universal propositions are the same. But *terms* are examined, not from a maximum downwards in one case, and a minimum upwards in the other, but from a maximum downwards in both cases; and the effect of this difference is so marked that it might perhaps be desirable the words universal and particular should not be applied to both propositions and terms.

A term is *universal*, extensively or intensively, when the verification by induction requires examination of the whole extension, or of the whole intension, of the term: otherwise it is *particular*. Thus in the particular proposition 'X and Y are coinadequate' both terms are extensively universal: for though a part of the universe may furnish verification, that part must be ascertained to be out of the whole extent, both of X and Y. But both terms are intensively particular: for if any component classes of X and Y be together inadequate, so must be any compounds of those classes: consequently, a pair of components may settle the matter. Speaking metaphysically, the proposition is 'X and Y are inalternative:' if any one component attribute of X, and one of Y, be not necessary alternatives, neither are X and Y.

The extensively universal is always intensively particular; and the extensively particular is always intensively universal; and their converses. Both descriptions exist in both readings. I shall use the phrases *quantity universal and particular* for mathematical reading, and *force complete and incomplete* for the metaphysical reading: both having their *extensive and intensive*. But, though all this distinction be in thought and nature, it is not all in habit or *second nature*. The extensive is almost exclusively limited to the mathematical; the intensive to the metaphysical: so that universal and particular quantity of extension, complete and incomplete force of intension, will be the great working distinctions.

In the notation for mathematical reading $X)$ and $(X$ denote X taken *universally in extension* and particularly in intension: and $X($ and $)X$ denote X taken *particularly in extension* and universally in intension. In metaphysical reading $X]$ and $[X$ denote complete force in extension, and *incomplete force in intension*: $X[$ and $]X$ denote *complete force*. Our usual habit, then, will be to consider $X)$, $(X$, $X[$, $]X$, as universals; $X($, $)X$, $X]$, $[X$, as particulars.

A proposition is determined so soon as its quantities and quality (affirmative or negative) are determined: this is inductively derived from the lists. Hence the proposition is completely symbolised by terms, quantities, and quality. To say 'I speak in extension, affirmatively, universally of X , particularly of Y ' must be to say ' X is a species of Y ,' and is denoted by $X)) Y$, or $X) () Y$.

When a term is changed into its contrary, the spicula must be changed, and the mark of quality. Thus $X)) Y$ is $X) (y$, and $x () Y$ and $x ((y$. A term and its contrary* have always opposite quantities, and opposite forces.

A term used particularly may be replaced by a stronger of its own *tension* (extension or intension): a term used universally may be replaced by a weaker of its own tension. Deductive truth remains, though not equivalence. We have here the whole principle of common, or onymatic, syllogism.

We may state it thus, and more widely.

In *universal terms* of either tension, elements of that tension are *dismissible* and *inadmissible*. Thus $A, B)) CD$ gives $A)) C$: but $A)) C$ does not give $A, B)) C$.

In *particular terms* of either tension, elements of that tension are *indismissible* and *admissible*. Thus $A)) B$ gives $AC)) B$: but $A)) B, C$ does not give $A)) B$.

In universal *propositions*, *indismissibles* are *transposable*, directly in negatives, by contraposition in affirmatives. But *dismissibles* are *intransposable*. Thus in $AB)) Y$, A is *indismissible*, but *transposable* by contraposition; $AB)) Y = B)) Y$, a. But in $AB) (Y$, the *indismissible* A is directly *transposable*; $AB) (Y = A) (BY$.

In particular *propositions*, *dismissibles* are *transposable*, directly in affirmatives, by contraposition in negatives. But *indismissibles* are *intransposable*. Thus in $A, B () Y$, where A is *indismissible*, it is *intransposable*: but in $AB () Y$, the *dismissible* A is directly *transposable*; $AB () Y = A () BY$. And in $AB ((Y$, we have $B ((Y$, a.

The root of these distinctions may be clearly seen in the distinction of propositions as either affirming or denying coexistence. But I defer the consideration† of this point to a subsequent paper.

* When a universal is converted into a particular merely by inserting or withdrawing a symbol of negation, the particular so obtained, joined to the universal, limits the extent of the universal, as in the following cases:

$))$, a species; $) ($, but not the largest possible.
 $) ($, an external; $) ($,
 $(($, a genus; $(($, but not the smallest possible.
 $()$, a complement; $()$,

The distinction thus drawn between $))$ and $) ($, on the one hand, and $(($ and $()$, on the other, might be worded in many ways.

† I hope at some future time to treat of a pure form of opposition which runs through all contraries. In my last paper I gave some account of the way in which various words may be made to replace each other, at least so far as this, that either may be described in terms of any one of the others. An eminent critic thereupon says that I "formally identify" these terms. If this mean that I say, *in form*, that they *are* identical, he is not correct: but if it mean that I contend for a *common form* running through all logical oppositions, he is correct so far as this, that I ventured to predict the future establishment of such a form. My critic adds that my system

XXXVI. The *syllogism* is inference of the relation which exists between two terms, as a necessary consequence of their relations to the same third, or *middle*, term. When the relations are *onymatic*, so may be called the syllogism.

The perception of the validity of a syllogism is the perception of the combination of two relations into one. This is frequently the case even in the common mode of stating a syllogism, in which *premises* (the two expressions of simple relation) and *conclusion* (the expression of the compound relation) are stated in the arithmetical whole. If the common form be not compelled to accept the name of a syllogism of *first intention*, it is because the act of mind in forming the conclusion may be based on notions of second intention.

Some pairs of relations combine into one relation. Thus a species of a species is a species: but a species of a copartient may be any one of the eight relations.

The *major term* of a syllogism is that term of the conclusion to which the other is related, or the predicate: the subject of the conclusion is the minor term. The *major term* is the one to which the *action* of the syllogism points: in this way. We see that $X \rightarrow Y$ and $Y \rightarrow Z$ give $X \rightarrow Z$, which may be expressed thus:—the species of an external of Z is an external of Z : here Z is the major term. But in reading backwards, as 'The external of a genus of X is an external of X ,' we see that X is the major term.

The natural character of the *first figure* will now be seen, as the most simple expression of the combination of relations: but it is somewhat obscured by the usual order of writing the premises. The fourth figure is less natural, because it converts the expected relation. The second and third figures are less natural, because they do not present the relations to be combined, but one of them and the converse of the other.

Every syllogism may be read, with reference to one set of terms, in sixteen ways. For any term may be changed into its contrary, and the proper change of relation made: this gives eight ways of reading; and inversion of order gives eight more. But when we drop the terms, and consider merely combination of relation, the sixteen are only two repetitions of the same eight, when both premises are universal.

Two universal premises always give a conclusion, universal when the middle term is of different quantities in the two premises, particular, when of the same. A universal premise coupled with a particular always gives a conclusion when the middle term is of different quantities in the two; and not otherwise. But universal premises with a particular conclusion would allow as strong a conclusion if either premise be properly weakened into a particular: hence I called such a syllogism *strengthened*. A syllogism with a premise stronger than needful for the conclusion, or with a conclusion weaker than needful from the premises, is a logical argument, but one which should not be allowed to stand in the same class with the *fundamental** syllogism which has all that can be got from premises which are no stronger than

is a *witches' cauldron*: I accept the phrase. Algebra is a *witches' cauldron*. It has two handles, + and -. By these we lift on the fire, at once, the distinctions of addition and subtraction, multiplication and division, up and down, north and south, east and west, loss and gain, before and after, gravity and levity, attraction and repulsion, &c. &c. &c. They all boil together, and the results are magical. The spell was

impaired by the long time which certain roots (of negative quantities) took to boil; but they are now quite done. The logical cauldron, of which I have some further knowledge, I hope to set boiling at some future time.

* Had this distinction been made from the beginning, it would have been seen that it is as necessary to a fundamental syllogism that the middle term should enter once particularly,

is necessary. How completely the entrance of such syllogisms has defaced the Aristotelian system, will easily appear: it has been well said that Aristotle commenced his synthesis before he had completed his analysis; a thing which is almost always done by the first organiser of any science or branch of science.

If the relations A and B combine into C, it is clear that A without C following means that there is not B; and that B without C following means that there is not A. This important principle, known only to the old logicians, in their practice, as a mode of reducing two obstinate mal-contents into the first figure, might have led to such a classification* of syllogism as the following.

Throw out all needlessly strengthened or weakened forms, and there remain four syllogisms in each of the first three figures. These divide into four cycles of three each, one out of each figure: and in each cycle each syllogism is what I have called an *opponent* of each of the others; that is, has the form in which one premise admitted, and the conclusion denied, denies the other premise. As follows:

		<i>Figures.</i>		
		I.	II.	III.
<i>Cycles.</i>	1	Barbara.	Baroko.	Bokardo.
	2	Celarent.	Festino.	Disamis.
	3	Darii.	Camestres.	Ferison.
	4	Ferio.	Cesare	Datisi.
<i>Figure IV.</i>		Camenes	Dimaris.	Fresison.

The fourth figure, always marked by the rest with some symptom of dislike, is here absolutely excluded. It has three syllogisms which form a cycle by themselves.

XXXVII. I shall not repeat the details of my former paper on the relations of the syllogistic forms. It will however be worth while to state the following arrangement of the forms, which is, I think, the best I have given.

	VVP	PVP VPP	VVV	VPP PVP	VVP		
FFF	$\left(\left(\left(\left\{ \begin{array}{l} \cdot ())) \\ : ((() \end{array} \right\} \cdot)))) : \right))) (: \left. \begin{array}{l}))) (: \\) ((. \\) ((. \end{array} \right\}))) (($				FFF		
NNF		(.) (.)	$\left\{ \begin{array}{l} \cdot (\cdot (\cdot) \\ : (\cdot) \cdot) \end{array} \right\} \cdot) \cdot (\cdot) : \cdot) \cdot ((: \left. \begin{array}{l}) \cdot ((: \\) \cdot (\cdot \\) \cdot (\cdot \end{array} \right\}) \cdot (\cdot) \cdot ($			NNF	
FNN		(() \cdot ((((((((((((((((FNN
NFN		(\cdot) ((((\cdot) ((((((\cdot) ((((((\cdot) (((((NFN
	VVP	PVP VPP		VVV	VPP PVP	VVP	

as that it should enter once universally. And it would have been seen that if there be any rule at all on the subject, it must be this one. For every syllogism may have the middle term changed into its contrary: it cannot be the rule, then, that the middle term should enter universally twice; for then there would be a class of syllogisms in which it enters particularly

twice; and *vice versa*. Consequently the rule must be, if a rule there be, that the middle term has one universal and one particular entry.

* This was communicated to me by my friend Sir William Rowan Hamilton (Feb. 14, 1856), as a consequence of my mode of expressing the connexion of premises and conclusion.

F, affirmative; N, negative; V, universal; P, particular. The compartment NFN contains all the syllogisms in which the first (minor) premise negative and the second premise affirmative give a negative conclusion. The columns (PVP), (VPP) contain all in which the one premise is particular and the other universal. The middle column contains all the universal syllogisms. It is flanked by four compartments of six each: and each one compartment contains all the syllogisms of one particular conclusion. Thus all in the upper left flank give the conclusion (). The canon* of validity is as follows:—Every pair of universals gives a conclusion: and every universal and particular in which the middle terms are of different quantities. The canon of inference is:—Erase the symbols of the middle term, and what is left shews the conclusion. Thus ())(gives ((, by which I signify that the *copartient of an external is exient*: or reading metaphysically, []][gives [(, the *irrepugnant of a repugnant is independent*. Supplying the terms, we have X () Y)(Z gives X ((Z; or, on the *abacus*, ‘Some Xs are Ys, no Y is Z; therefore some Xs are not Zs.’

XXXVIII. Thirty-two combinations give valid syllogisms; and as many are invalid. Sixteen of these invalid combinations, of which eight repeated twice, in conjunction with eight of the valid forms, thirty-two in all, have a meaning of their own, as follows. The form of our syllogism is, A, B, C being relations:—

Every A of B is a C.

Now there are† also thirty-two truths of this form, derivable as follows:—

Every A is a C of every (converse of B).

Thus every complement of every *species* is a complement: therefore every complement is a complement of every *genus*. Again, every genus of every *partient* is a partient: therefore every genus is a partient of every *partient*. The symbolic rule is as follows:—Choose any one of the thirty-two combinations in which the middle spiculæ are of *different* quantities. Reject a universal followed by a particular. In any other case, strike out the middle spiculæ, and if the result be a universal, either let it stand, or change the second spicula: but if the result be a particular, there is no choice but to change the second spicula.

Thus (()) is inoperative: there is no relation A of which we can say—Every A is a

Let $P + Q = R$ express that P and Q, coexisting, give R: let $-P$ represent the contrary of P (or contradictory); let \emptyset be the symbol of impossibility of coexistence. If then P, Q, R be three propositions which cannot coexist, so that $P + Q + R = \emptyset$, we have three modes of inference $P + Q = -R$, $Q + R = -P$, $R + P = -Q$. Now *Barbara* may be expressed thus

X)) Y + Y)) Z + X ((Z = \emptyset
whence X)) Y + Y)) Z = X)) Z *Barbara* I.
Y)) Z + X ((Z = X ((Y *Baroko* II.
X)) Y + X ((Z = Y ((Z *Bokardo* III.

This process is carried through all the syllogisms of the first figure.

* There are various ways in which the symbols may be put together so as to give all the syllogistic forms by consecutive pairs. Thus the following set

))) (()

taken cyclically, that is, the first and last being considered as

neighbours, give all the eight universal syllogisms in consecutive pairs, if we read both backwards and forwards. And under the same rule, eight particular syllogisms are seen in each of the two following cycles:

))) (()
))) (()

The following conceit gives a kind of *zodiac of syllogism*. Put round a circle the twelve symbols here consecutively written, distinguishing the universals by the thicker parentheses;

)))))) (() (()) ()

Any two consecutive universals give a universal syllogism: any universal with a *contiguous* particular gives a particular syllogism. And these whether we read forwards or backwards.

† If $\phi\psi x < \chi x$ for all values of x , which is the proper analogy for the composition of relations in the syllogism, then $\phi x < \chi\psi^{-1}x$, but we must not say $\psi x < \phi^{-1}\chi x$.

complement of every partient. Now take () (·) which, the middle spiculæ being erased, gives (·), a universal; changing the second spicula, (·(

Every complement is a partient of every complement

Every exient is a partient of every complement.

The first is only a strengthened form of the second. Syllogisms being combinations, these relations may be called *decombinations*. From the strengthened syllogisms proceed the strengthened decombinations: from the syllogisms in which universals give universals the decombinations in which a universal gives two universals. The sixteen remaining cases arise from the particular syllogisms. The sixteen pairs, such as (·) () &c., and the eight (·) (·) &c. which are not decombinations, are no doubt of some logical import which I do not now see. These decombinations are the contrapositives of the combinations. Thus 'Every external of any genus is an external' gives every non-external (partient) is a non-external (partient) of any genus, or () gives () ((, as from the rule.

XXXIX. The full stops and colons in the table denote that one of the syllogisms between which they stand is formed from the other (proceeding from the middle column) by altering the first or second premise. Thus (·) (·) is formed from (·) (·) (by weakening the universal) (into) (·). But (·) (·) is formed from (·) (·) by strengthening the second premise) (into (·). Accordingly, the eight strengthened syllogisms are those which are under VVP.

I shall write down and illustrate one syllogism in the three readings: namely) ((· (which gives) (.

<i>Arithmetical.</i>	<i>Mathematical.</i>	<i>Metaphysical.</i>
X).(Y No X is Y.	X co-external of Y.	X repugnant of Y.
Y).(Z Some Ys are not Zs.	Y exient of Z.	Y independent of Z.
X) (Z Some things neither Xs nor Zs, i. e. as many at least as there are Ys which are not Zs.	X external of exient of Z, or coinadequate of Z, by all the extent at least by which Y is exient of Z.	X repugnant of independent of Z, or inalternative of Z, by at least all the force of Z which is not in Y.

Take the instance of metaphysical reading previously given, "Courage (moral) and meanness are inconsistent ideas, and courage is not dependent on personal strength, so that strength and meanness are not necessary alternatives." Courage does not depend on strength: a man wanting strength may therefore have courage, which puts meanness out of the question, so that a man may have neither strength nor meanness, or we must not say he must have one or the other or both. It is said that the force of this proposition is all the force of the word *strength* which is not in *courage*. Courage not depending on strength, the latter has attributes which are not in the notion of courage: say health. Ill health is a field of intensive force for the verification of the proposition: the want of strength may arise from ill health, which is consistent with courage, &c.

It is impossible that the logician can fully represent this case of common thought in his syllogism:—"All courageous is not mean, some courageous is not strong; therefore some not strong is not mean."

XL. When quantity or force is particular or incomplete in a term of the conclusion, that quantity or force is derived as follows:—

1. VVV. If there be only one particular term in the conclusion, that term takes the whole quantity or force of the other term: but if there be two particular terms, one has the quantity or force of the middle term, the other of its contrary.

2. VVP. The particular term, or both if there be two, takes quantity or force from the whole middle term, if the middle term be universal in both premises; and from the whole contrary of the middle term, if the middle term be particular in both premises.

3. PVP and VPP. The particular term or terms in the conclusion take quantity or force from the particular term in the premise.

For example, let $X \supset Y \supset Z$ give $X \supset Z$ in the form $x (\cdot) Z$, with both terms particular. Everything is either x or Z . What extent of x are we sure of? an extent equal to that of y . And of Z , to fill up the universe, there remains the whole extent of Y .

Again, to apply symbols to a material example,

health]] temperance]] sobriety gives health]·[excess in liquor.

The conclusion has both terms intensively particular. The forces of the repugnant terms health and [habit of] intoxication, are merely those of temperance and intemperance: health is a more intensive term than temperance, but we have not, in the argument, to do with any essential of health except temperance; or with any essential of intoxication except intemperance. Or, as people will sometimes say, 'to shew that health and intoxication are repugnant, it is enough to say that temperance is not intemperance.' This seems to many to be only a metaphorical heightening of contrast by substitution of explicit force of verbal *contrariety* for things which are *as repugnant as* contraries. But it is not so: it means that the intensive forces of a conclusion are in thought, and ought to have been in logic. The world sees—without knowing precisely what it sees—that the abacus process—"All healthy is temperate; all temperate is sober; therefore all healthy is sober: but no sober is drunken; therefore no healthy is drunken"—does not express its form of thought, though it be *Barbara* and *Celarent* in one.

XLI. The first figure is the most commodious: the fourth is nothing but the first with its conclusion read backwards; both these have been completely canonised. The symbolic rules for the second and third figures are very easily deduced: but I shall not swell this paper with them. If we consider premises only, there are but three figures. Each conclusion reads in two orders, which is no variation in two of the figures, and makes all the distinction between the first and the fourth. Now if we remember that premises are imposed upon us, but order of conclusion is our own choice, we see that the fourth figure is our own doing.

When both premises are mathematical, or both metaphysical, figure is a truly unessential variation, if the mind be equally accustomed to all modes of perceiving validity. All the duties which have been appropriated to the several figures seem to me to be fictions, so long as there is but one kind of reading. When the two propositions are of different readings, there is then a difference in the form of thought in different figures. The cases in which this occurs must be those in which the middle term is of the same reading in both, a mode of thought which must come first or last.

In the physical and contraphysical forms, it is not necessary to invent more schetical words: any term may be carried to another by its own reading. Thus we may call class a

species of attribute and attribute an *essential* of class, in physical reading: and attribute a dependent of class, or class a *genus* of attribute, in contraphysical reading. We might even, on occasion, join the words of the two readings, in an order reverse of what we come from and what we are going to. Thus class may be a *dependent species* of attribute, and attribute a *genus essential* of class, in physical reading: while attribute may be a *class dependent* of class, and class an *essential genus* of attribute, in contraphysical reading. But no advice can be given on this point: such a familiarity with all the schetical words as we have with *species*, will dictate the form of mixed reading.

When both premises are physical, the first figure does not exist. In the second figure we compare classes by reference to a common attribute: in the third figure we compare attributes by reference to their relation with a common class. In the Aristotelian system, that is, confining ourselves to propositions in which we do not expressly deal with the whole universe, the second figure has no affirmative conclusion: that is, partience or inclusion cannot be inferred of two classes by reference to one attribute. And the third figure has no universal conclusion; that is, essentiality or repugnance of two attributes cannot be inferred by their relations to one class. This is more than technical knowledge; or would be, if duly expanded.

When the premises are of different kinds, with middle terms of the same reading, we have as follows, if we exclude the contraphysical form. The first figure yields only physical conclusion, from premises mathematical and physical, or physical and metaphysical. The second figure yields only physical conclusion, from premises physical and mathematical. The third figure yields only physical conclusion, from premises mathematical and physical.

The fourth figure, when both the premises are not of the same reading, and the middle term of the same reading in both, cannot exist without a contraphysical proposition, either in one premise or in the conclusion.

POSTSCRIPT.

THROUGHOUT this paper I have abstained from all mention of the name of any opponent of my views. This omission would have been an unpardonable affectation if there had not been a good reason for it: consequently it would appear in that light but for a good explanation. Had I taken the usual course, the name of a personal opponent and accuser would have struck the eye so often, that I should have been liable to serious misconstruction: not indeed from those who should carefully read my paper, but from the much larger number who would look over its pages on the way to other matter. Had I given one name its due frequency of mention, I should have been supposed by the turner of the pages to be continuing that kind of controversy which death should always interrupt: had I made an exception of that* name only, I should have appeared to the *reader* as ignoring, from personal motives, a memory which cannot be ignored in a branch of psychology from any worthy motives whatsoever.

* This must be my apology to Mr Baynes, Mr Mansel, Mr Mill, Mr Spalding, Dr Thomson, and perhaps others, for my omission of direct allusion to them in my production of and remarks on their opinions.

I need hardly say that I allude to the late WILLIAM HAMILTON—a name which I hold entitled to the honour of losing its conventional accompaniments. And first, I take this opportunity of acknowledging the essential benefit which he conferred on my speculations. A mathematician might have written long enough upon logic before he would have attracted the attention of the readers of Aristotle. John Bernoulli and James Bernoulli (as I discovered by accident five years ago) both wrote on the subject, and so did Lambert: and all three on the proposition. But I doubt if Hamilton himself—the most omnivorous of readers—ever knew of the Bernoullis as writers on logic: and it is clear that he had no particular knowledge of Lambert before 1850 or thereabouts. Accordingly, my views might easily have remained the sole possession of the few mathematicians who study thought as thought. But when the most eminent teacher of logic of the century not only put himself in opposition to me at the outset, but affirmed his conviction that important parts of my views were derived from his own private communication to me, he gave me such an introduction* to his fellow-students as I should not have had the wit to contrive for myself, though the ordering of events had been unreservedly placed in my own hands. And what is the consequence? The writer of a manual omits to mention my name or to allude to my views—only, as afterwards stated, to avoid controversial description—and he is put upon the dilemma of culpable suppression or almost incredible ignorance in the very first journal which notices his book. And for this I have entirely to thank my opponent, who was well entitled to say of me,

Iste tulit pretium *jam nunc* certaminis hujus,
Quo cum victus erit, mecum certasse feretur.

It is due to the Society as well as to myself that some notice should be taken of the *Discussions on Philosophy* (first edition, from page 621* following 620 to page 652* preceding 621, second edition, pp. 676—707). There I find accusations of (unconscious) plagiarism, ignorance of elementary logic, and misrepresentation, coupled with reflections on the Society, extended even to the University, for the admission of such matter into their *Transactions*. I can afford to supply the word *unconscious*. First, because the charge is not made in terms which necessarily impute knowledge, while the retraction of a previous accusation, so far as wilful taking was concerned, leaves me at liberty to think that the second accusation was of the minor offence. Secondly, because I never knew of any journal, nor of more than one individual, who held that I had, even unconsciously, derived anything from the communications made to me, which have now been ten years before the world. I shall, in the briefest manner, take all necessary notice of the three things mentioned.

Unconscious Plagiarism. Lambert unquestionably gave the definite quantification of the middle term. I never saw his *New Organon* till long after my first paper was published. When I saw it, I did not look at the part† which treats of this quantification: of which I

* To the discussion which followed it is due that Mr Boole turned his thoughts again to his old notes, and put his system into a form for publication. I need hardly say that this system is the true exhibition of the onymatic form of thought in the language of algebra.

† It is in the part of the book which treats of *probabilities*, in a different volume from the syllogism; and I dare say some

will have found it difficult to believe that I, of all persons, should neglect that part of the *Neues Organon*. But I had both a subjective and an objective reason for abstaining. My acquaintance with German is just enough to spell out mathematics, in which a person used to the subject reads in almost any European language. Again, the copy I used was borrowed, and was bound with marbled edges by an owner who

first knew the existence from Mr Baynes's *New Analytic* (1850, July). Ploucquet gave, according to my critic, the following rule: *Deletur in premissis medius: id quod restat indicat conclusionem* (pp. 630*, 685); but in what work is not stated, nor whether Ploucquet used *symbols*. My rule is:—Erase the symbols of the middle term; the remaining symbols shew the inference. It is assumed that I derived this rule from Ploucquet. I answer that, in the second appendix to my *Formal Logic* (p. 323) I gave what then* was “all I know of any attempt to deal with the forms of inference otherwise than in the Aristotelian method.” I had one borrowed work of Ploucquet in my hands for a few weeks; the only one of that writer I ever saw: I gave all I got from it. If the *methodus calculandi* described by me in page 333 be what † was meant, it will be seen to have not even a remote resemblance to my method: if not, I never saw what was meant. My *quantum*—very far from *sufficit*—of research in logical bibliography does not, at this moment, bear the most remote comparison to what some of my writings prove as to mathematical bibliography: and in 1849 it was much less than now.

Ignorance of elementary Logic. To the general charge my writings must reply. But there are especial instances, which are quoted or referred to in three of the critic's writings. I have never been able to find the source of more than one of these instances. In giving an account of it, I cannot but express my conviction that the author of the imputation had lost some of his habit of deliberate reading, and that the misinterpretation of my meaning, and the indisposition to refer back, are to be attributed to ill-health.

The assertion is that I had confounded the *middle term* of a syllogism with its *conclusion*. The ground of this assertion is the following sentence in my *Statement in Answer* &c.: the

had never used it. Many must know that when the older German paper is marbled, the leaves stick together at the edges in such manner that not the smallest crevice can be found for the end of a paper knife: and liberties which may be taken with an oyster must not be taken with a borrowed book; which put very serious difficulties in the way, and prevented even a cursory glance at all parts which I did not open. When I borrowed the book for the second time, after seeing Mr Baynes's work, I found that all the part on probabilities had never been opened. Had I opened this portion the first time, I could have learnt nothing more than the Society had published by reading more than a year before, and by printing six months before: but it would have been my duty to have stated what I had found.

* I add, so far as notes or recollections serve, what I have arrived at since. First, it is stated by Hamilton that Frommichen gave the numerical quantification of the middle term: but whether from Lambert, or independently, is not stated. Secondly, George Bentham, in his *Outlines of a new system of Logic*, (1827) made a universal quantification: but it is clear that he misunderstood some of its forms. A discussion arising out of this work, between Mr Warlow of Haverfordwest, the promoter, Hamilton, Dr Thomson, Mr Baynes, and others, took place in the *Athenæum Journal* (December 1850—March 1851, Nos. 1208—1218). Thirdly, Mr Solly did the same, as noted in my last paper. Fourthly, Christopher Sturm, in his *Universalia Euclidea*...printed by Adrian Vlacq (Hague, 1661, 8vo. small) gave 12 forms of syllogism in which, the premises being Aristotelian, the contrary of one of the terms in the premises is allowed to be the *subject* of the conclusion. Thus from A)·(B and B)·(C he deduces c(·(A.

I have already mentioned the Bernoullis. Their logical papers are heads of theses, in which both, but especially James Bernoulli, import the algebraical mode of thought into logic. They both take the distinction of extension and comprehension from the Port-Royal Logic, of which both were readers. James Bernoulli compares the common attribute of two notions to the common measure of two numbers, thus confirming my assertion that a mathematician would, of course, compound attributes, and not aggregate them. (Joh. B. *Works* i. 79; James B. *Works* i. 177, 213, 228).

Lastly, while writing this note, accident led me to a paper by Louis Richer, in the volume for 1760-1761 of the Turin Memoirs (the one which contains Lagrange's celebrated paper on sound). This paper contains, among others, the very symbols I have used to distinguish propositions: but the object is to symbolise the notions of metaphysics. Thus (·) is necessity, (·) when positive, (·) when negative; and (·) is contingency.

† My opponent had not my work before him, by his own act. He returned me the copy which I sent to him, in displeasure at my comments on his own accusation and its consequences; apparently denying, or at least not apprehending, that the copies of controversial works which pass between antagonist writers are no more *favours* than the gloves which used to pass between combatants of another kind. From this circumstance, and from internal evidence, I conclude that when he (pp. 649*, 704) pronounced me acquainted with the *logical writings* of both Ploucquet and Lambert, he spoke from vague recollection of my appendices, which were returned cut open.

word *former* referring to my first paper on syllogism:—"In the former I have expressed the quantity of my conclusion, there called *the* middle term, being as much as is really *middle*, by $m + n - 1$..." My critic made what I call a wrong* *hyphenism*: he read it "quantity of my conclusion-there-called-*the*-middle-term" instead of quantity-of-my-conclusion, there called the middle term." If two leaves had been turned back, so that the extracts from "the former" should have met the eye, there would have been seen—"If these fractions be m and n , then the middle term is *at least* the fraction $m + n - 1$ of the Ys." The meaning is clear. If the fraction m of the Ys be Xs, and the fraction n of the Ys be Zs, then the extent 'the fraction $m + n - 1$ of the Ys' is really in both terms, and is "as much as is really *middle*." I defend the grammar of my phrase, though not its sufficient completeness: but it is well enough for an allusion to matter of four pages back. In 'the A of my B, there called C,' C refers to A, unless context make it very apparent that the writer is not correct. If I had wanted to refer C to B, I should have said, 'the A of my B, which B is there called C.'

* I should have left the cause of this *wrong hyphenism* to the conjecture of my reader if I had not, while this paper was in proof, noticed the juxtaposition and opposition of the two passages given below. I have long been satisfied that I knew why a metaphysician who, right or wrong, was seldom weak, proclaimed the quantitative sciences of space and time to be mental nuisances; but, except for the passages now given, I could not have pointed to the explanation without much colla-

"This being understood, the Table at once exhibits the *real* identity and *rational* differences of Breadth and Depth, which, though denominated *quantities*, are, in reality, one and the same quantity, viewed in counter relations and from opposite ends. Nothing is the one which is not, *pro tanto*, the other."

Of two quantities, then, which are "one and the same quantity," the less the one, the greater the other! The writer of these passages never failed to convey anything he really had to convey, by want of power over language: when the Bank ran short, he knew the way to the Mint. But he was here suffering under an insufficiency of notion. He wanted to grasp the idea that of his two quantities one *determines* the other. The conception of functional relation was struggling in a mind which could not furnish it with a *locus standi* for want of an adequate conception of quantity. A little further on he proceeds thus:—"Though different in the order of thought (*ratione*), the two quantities are identical in the nature of things (*re*). Each supposes the other; and Breadth is not more to be distinguished from Depth, than the relations of the sides, from the relations of the angles, of a triangle." Had "identical" here had its meaning, it would have been absurd to say that Breadth and Depth are "not more" distinct than the relations of the sides and the relations of the angles of a triangle: it ought to have been "not so much by a great deal." But, as it is, and choice of word apart, my eminent critic is right: Breadth and Depth have relations each to the other. The word "identical," as used by him, symbolises his aspiration after the notion of mutual dependence, which mathematicians call functional relation. He has pushed to an extreme a liberty with the word *identical* which is not uncommon among logicians. They start from " X is X " as the expression of *identity*; and their extensions of the verb involve exten-

tion and laboured inference. I hope the reader will verify for himself, first, the following quotations, next, my assertion that the context would not reconcile them in the slightest degree. In both editions of the *Discussions*, within eight lines of each other, and as parts of the same train of thought, occur the following sentences (1st. ed. p. 644*; 2nd. ed. p. 699). The "table" and the "diagram" are one.

"The two quantities are thus, as the diagram represents, precisely the inverse of each other. The greater the Breadth, the less the Depth; the greater the Depth, the less the Breadth; and each, within itself, affording the correlative differences of whole and part, each, therefore, in opposite respects, *contains* and *is contained*."

sions of the substantive. But they do not handle simultaneous extensions of cognate words with as much facility as the mathematicians, to whom the process is of constant occurrence, sometimes forced upon them by the progress of their science, sometimes excogitated, *pro re nata*, to forward that progress.

Quantity, in the mind of my critic, was the *res divisibilis* (§ XXI); and not correctly conceived even in this sense. We may now see how it comes to be affirmed, in the dissertation I have quoted, that *equation of quantities* is convertible with *coalescence of notions*, and *equation with identification*: that a competent notation must "sublimate into one" identical quantities: that though a proposition be "merely" equation of quantities,—two Breadths, or two Depths,—it may, at will, be considered in neither quantity. No one of these assertions wants truth, provided that clear meaning be given by reduction of "quantity" within its true limits, and restoration of "coalescence" to its proper place. Other writings of the same author contain phrases illustrative of the theory on which I account for those already produced. Such as that moods are *numerically equal* in all figures; meaning that all figures have the same numbers of moods: such again as the phrase *amplification of number*; meaning the addition of other number to it: such again as *addition* to the *number* of things described as *increase* in the *things* themselves. And lastly, *quantity* of the conclusion not merely confounded with the conclusion itself, but the confusion attributed to a mathematician. (June 25, 1858.)

Misrepresentation. In my second paper, speaking of complete quantification, I presumed that, as had been done by various writers who quantify the predicate, the words *some* and *all* would be made the words of quantity: so that, when quantity is expressly given, "No X is Y" would become "All X is not all Y," and the like. Not that I complained of this awkward language: on the contrary, though I called it forced in order and phraseology, hard to make either English or sense of, I said that in its place in the system alluded to, the uncouth expression helps to produce system, and the perception of uniform law of inference. So I thought, and so I think still. The entrance of the exemplar *any* into the negatives, while *all* is used in the affirmatives, appears to me a symbolic blemish, though no doubt it is a grammatical propriety.

But as the system really does not proceed as I said it did, there is misrepresentation. My affair with it now is to shew that I had presumptive grounds for making the statement in my second paper. They were as follows:

In the prospectus of a work on logic, not yet* published, which prospectus appeared in 1846, my critic describes universal quantity as an *extensive maximum undivided*, and *universal* quantity is called *definite*. Now the maximum of extension, undivided, and definite, is *all*; the word *any* both indicates division, and is indefinite. No hint is given that in negatives the universal is represented by a maximum of extension divided by a word of indefinitely selective import.

In my work on logic (p. 302), forming the system from conjecture, I attributed the phrases afterwards repudiated by my critic; and this part of my work I knew to have been seen by himself. Opportunity of correction subsequently offered itself in the statement of the system furnished to Dr Thomson, for the second edition of his *Laws of Thought* (1849). But no such correction was made; the explicit propositional forms were not given; and the only hint on the subject which this work contains is the hint in the notation, more fully spoken of immediately, in reference to another work.

In July 1850, just after the last revise of my second paper had been sent to Cambridge, but in time to have recalled it, I received Mr Baynes's *New Analytic*. I looked at all parts of this, at once, with a view to correction. I found no propositional forms, but only such an account of the syllogistic notation as would allow no other phraseology except what I had used. We are told, in more places than one (pp. 76, 151, 155) the last in a note by Hamilton himself, that the colon (:) denotes *all*, and no other rendering is given. Thus "there is denoted by the sign [:] *all*" and "the colon (:) to denote 'all' (definite quantity)" and "the colon denotes universal quantity 'all.'" In the notation, A : — : B is intended to be read "All A is all B," and A : + : B, the symbol + denoting negation, cannot, *according to directions*, be read in any other way than "all A is not all B." Most of the instances in the body of the work are material, and common words and elisions are employed. I did afterwards find a negative form (I believe such a thing occurs only once) thus—"No C is any B:" but even had

* It is to appear under the editorship of the Rev. H. L. Mansel, but I am afraid the state in which the papers were left will cause some delay. I understand that all which relates to quantity is left in a scattered state. The technical phrases of

logic had been worn and torn until they were almost unintelligible. Hamilton's remarkable power over language gave some new life to almost every subject he touched: and logic will, I believe, not be found among the exceptions.

I noticed this in the first examination, I could not have accepted, as a formal component of that system which rests entirely on explicit announcement of every quantity, a form in which the semi-copular, semiquantitative word "no" is used.

Lastly, in proof that I might have avoided the misrepresentation, my critic referred me to certain mnemonic verses which he had published in 1847, of which the first stanza is

A it affirms of this, these, all,
 Whilst E denies of *any* :
 I it affirms, whilst O denies,
 Of some (or few or many).

But it is clear that, all other things put together with this, I could only look upon *any* as preferred for the convenience of rhyming; to say nothing of the word *any* referring only to the subject.

Thus I have, I think, established a reasonable right, then existing, to assume the 'extensive maximum undivided' as intended to be expressed by the word *all*, wherever and however it occurred.

I trust I have now done with the personal part of this controversy. Enough remains of scientific assault, as amply shewn in the preceding pages. But this concerns the living: and enough remain, again, to defend what is capable of defence, and to surrender what must be surrendered. For all else, I select two names from the rolls of fame in which my late opponent is now inscribed, and I join to Morhof's description of Julius Scaliger—*Totus nervosus est et rerum plenus, vehemens ipsi ingenium, audax, acre, judicium penetrans, nonnunquam etiam cavillatorium, ut solent viri etiam summi aliqua in re labi*—the question asked by Erasmus concerning Laurentius Valla—*Adeo nihil ignoscendum putamus ei qui tot modis profuit?*

A. DE MORGAN.

UNIVERSITY COLLEGE, LONDON.

August 3, 1857.

ADDITIONS AND CORRECTIONS.

§ II. I ought not to have used words implying that Boethius gave Aristotle *only* in summary, as he did Euclid.

§ IV. *Note.* I may add that it must not be inferred that the Ramist logic long prevailed at Cambridge to the exclusion of all other. It is likely that its complete predominance did not long outlive the personal career of Downam in the University. Of his work I cannot even trace a Cambridge edition. Of all the books used by Newton when very young, no one, as it happens, is recorded except Sanderson's *Logic*: which he read so attentively (Brewster, I. 21), that, when it was lectured on in College, he was found to know it better than his tutor. Such are the scraps

from which, for lack of historians, we collect what we can about the old studies of the University: though a contemporary comedy will give us more than a dozen subsequent biographies. Thomas Randolph, Ben Jonson's son in the Muses, and Fellow of Trinity College, who died in 1634, not aged thirty, must have written his *Aristippus*, the scene of which is laid in Cambridge, about or before 1630. The writers on logic then current in the University are told off as follows:—

Hang Brerewood and Carter in Crackenthorp's garter,
 Let Keckerman too bemoan us:

He be no more beaten for greasie Jack Seaton,
 Or conning of Sandersonus.

The last verse may mean that Sanderson was then *forbidden*, and *sub poena*. In 1680 was published at Cambridge a neat edition (8vo) of the Logic of Burgersdicius, with Heereboord's Synopsis.

It would be very desirable that such scraps should be noted by those who casually pick them up. I will undertake to arrange any that may be sent to me, and to deposit them in *Notes and Queries*.

§ VIII. It is hardly right to say that the distinction of extension and comprehension was wholly lost, till revived by the Port-Royal authors. It always existed as a metaphysical distinction, and, though not fundamentally laid down in logic, made no infrequent appearance. I think Occam, but I cannot now refer to his work, expressly applies the *whole* predicate to the whole subject; and whoever does so must think of the comprehension of the predicate. In speaking of the works which "carry on" the Port Royal distinction, I mean only to include those in which the *change of the quantity*, so well laid down by Arnauld, is distinctly stated, in some of its cases at least. Thus though William Duncan of Aberdeen speaks of extension and comprehension, I cannot find that he lays down anything on quantity. But Isaac Watts, in his excellent and much underrated work, which I call the English Port-Royal Logic, both lays down the distinction, and the universal comprehension of the predicate of an affirmative: this I have found only recently. But Watts says nothing about the predicate of a negative, as to comprehension. Nor have I anywhere found it laid down that in *all* terms of *all* propositions, the quantities in extension and in comprehension are of different names.

§ X. 3. For *animal-man* and *reason-man* read *animal-in-man* and *reason-in-man*.

§ XV. For 'X(or X(' read 'X(or)X.'

§ XXV. The doctrine of *modals* may, I think, be regarded as virtually incorporated into any system which acknowledges the distinction of the mathematical and metaphysical sides of logic. I never had the curiosity to examine the old modal proposition closely until long after the present paper was written: I now add a brief account of the difficulty of this subject, and of one reason of it.

There are *three* ways in which one extent may be related to another, definite expression of ratio being forbidden: they are, complete inclusion, partial inclusion with partial exclusion, and complete exclusion. This trichotomy would have ruled the forms of logic, if human knowledge had been more definite; if, for instance, whenever complete inclusion is deniable, it had been known which form of denial is the true one, denial by affirmation of partial inclusion with partial exclusion, or denial by affirmation of total exclusion. As it is, we know well the grounds on which predication is not a trichotomy, but two separate dichotomies. Nevertheless, when we come to speak metaphysically,

when our propositions are made to convey our impressions as to the nature of things, the trichotomy demands establishment. How indeed could beings who know *why* and *how* so soon as they know *what* imagine themselves incapable of choosing between two forms of denial? Accordingly, must be, may or may not be, cannot be, are the great distinctions of ontology: necessity, contingency, impossibility. This was clearly seen by the logicians. But it was not so clearly seen that this mode of predication tallies, not with the four ordinary forms A, E, I, O, but with the three forms A, (OI), E. As in the following:—Every X is Y, which is the consequence of necessity; Some Xs are Ys and some are not, which is the consequence of contingency; and No X is Y, which is the consequence of impossibility.

Accordingly, an attempt was made to pack up the trichotomy with the dichotomies. It ought to have been done in the following way, in which the proper modal description follows the form of predication; it being assumed that the categorical form which exists has its reason in the nature of things.

A. Every X is Y. Necessity.

O. Some Xs are not Ys. Non-necessity, i. e. either contingency or impossibility.

E. No X is Y. Impossibility.

I. Some Xs are Ys. Non-impossibility, or possibility, i. e. either contingency or necessity.

(O-I). Both Some Xs are Ys and some not. Contingency.

(A, E). Either Every X is Y or No X is Y. Non-contingency, i. e. either necessity or impossibility.

Instead of this, however, *possibility* was pressed into the list to make a fourth, but without any need; for the *contingens* was divided into the *contingens esse*, and the *contingens non esse*, and applied to the forms I and O; while the *possibile* was similarly applied, under the distinction of *possibile esse* and *possibile non esse*. But some separated the *possibile* and the *contingens*, applying the *possibile* to the form I, and the *contingens* to the form O. With them, *contingens* was equivalent to *possibile non esse*, and *possibile* to *contingens non esse*.

It must not be supposed that any of the objections I have hinted at were unseen or unnoticed. What, indeed, did the schoolmen not discuss? Two contiguous paragraphs of the minute Cologne commentary on Aristotle collected from Thomas Aquinas, Gilbert Porretanus, and others, address themselves to the questions why Aristotle did not introduce a single *modus* contradictory of *necessary*, as he had done in the case of *possible* and *impossible*; and why, since *possibility* and *contingency* are convertible, they are to be looked upon as distinct modes. The answers are too deep for me at present: but I have in so many instances found meaning in the schoolmen where I thought there was none, and sense where I thought there was nonsense, that I will not answer for the results of further con-

sideration. Nevertheless, I cannot but hold the choice and distribution of the modal forms to have been a real lapse, as well in Aristotle as in his followers: and it seems that the later philosophers of the middle ages had come to something like the same conclusion. Those who would see the modal system in its full perfection of confusion, should, if they will trust Crackanthorpe, consult the Jesuit Peter Fonseca, *qui totis quinque proliis capitibus de Modalibus agens, implicat se misere hisce spinis, nec tamen rem ipsam ullo modo explicat, sed velut alter Sisyphus, versat saxum sudans nitendo, neque proficit hilum: et propemodum facit ut lector intelligendo nihil quidquam intelligat.*

The application of the ideas of *necessary* and *impossible* to universals, and of contingent to particulars, was a mistake. It made a *truly* metaphysical conclusion the consequence of a mathematical form. *Omnis homo est animal*, taken to be a necessity because no exception was ever noticed, might have been a contingency: that is to say, it might have been, for aught the logicians knew, not merely *possible* for the Creator to have placed on earth—in a literal sense—rational and accountable vegetables, which they admitted, but even possible within the limits of the actual plan. And this mistake led to paralogsms. Thus, it was affirmed that a syllogism with a modal major might give a modal conclusion, though the minor was not modally given, but categorically. Thus from—It is necessary an animal should feel; every man is animal; they inferred it to be necessary a man should feel. Here one particular modality of the minor is tacitly assumed from its form; or else *conclusio sequitur partem deteriorem* was strangely forgotten. In what I have called the metaphysical form of the proposition, the question of necessity or contingency is left open. As the intention of thought in the premises, so also in the conclusion: necessary or contingent as the case may be. And any form may be thought as necessary, or as contingent: thus the *irrepuance* of two notions may be either, as well as their *repugnance*.

I was not at all aware, when I forwarded to the Society on one day two papers so different in their subjects as the present one and that on the beats of imperfect consonances, that both had some relation to the antagonism of the numbers 3 and 2. The inequality of 2^{10} and 3^{12} is the source of a great part of the difficulties of temperament: and it may be that the ill success of the attempt to assimilate a ternary and binary mode of subdivision was a large part of the reason why a fair and consistent juxtaposition of the mathematical and metaphysical forms of predication did not become a recognised part of logic.

Addition to Postscript. In my second paper I took some part of that distinction between extension and intension which I have developed in the present paper. On this point my eminent opponent (*Discussions*, 1st

ed. p. 643*, 2nd ed. p. 698), speaking of his own maxim that “the predicate of the predicate is, with the predicate, affirmed or denied of the subject,” proceeds thus: “In fact, if this principle be not universally right, if Mr De Morgan be not altogether wrong, my extension of the doctrine of Breadth and Depth, in correlation, from notions to *propositions and syllogisms*, has been only an egregious blunder.” I do not rejoice that of this I put myself upon the country, for two reasons. First, because the last phrase is not one in which I should like to join issue with such an opponent, alive or dead. Secondly, because there lurks in the sentence I have quoted a *fallacia plurium descriptionum*, which prevents it from conveying no more than the point at issue. Sir W. Hamilton’s principle is universally right, in its own meaning and in its proper place; but it is not contradictory of any thing brought forward by me; so that it does not make me altogether wrong. No one can dispute the principle when it is affirmed of qualities, distributed and separately residing in their subjects of inhesion. The difference between me and my opponent begins when he affirms or implies that his principle is, appertains to, or is in any way connected with, or even opposed to, the form of thought on which, from Aristotle downwards, has been based the distinction between extension and comprehension, denotation and connotation, logical whole and metaphysical whole, or whatever it may be called. This true and ever-abiding distinction is affirmed by Sir W. Hamilton, and denied by me, to be identical with that drawn by himself between *Breadth* and *Depth*. And this is the point on which issue is joined.

Addition to note in Postscript. On this proposal of Sturm’s Leibnitz, who describes it, remarks that the difference between a positive and privative term, or, what I call a term and its contrary, is of the matter of the term and not of the form of the proposition. Had he said that the distinction is of the *form* of the term, as distinguished from the form of the *proposition*, he would have been right: but there would have been no objection to take. Both Leibnitz and my critics should have objected to contrapositive conversion as material. But here, as in other cases, it is only the new introduction which is material: the established usage is formal. And this illustrates what I remarked in my second paper, namely, that the opposition really made is not of form to matter, but of what has been usually recognised as formal to that which has not.

It may be that the earliest attempt to augment the Aristotelian moods was that of *John Hospinian* (the Genevan divine was *Rodolph*) mentioned by Leibnitz as having appeared in a work published at Basle, 1560, 8vo. By pressing into the service indefinite and singular terms, and by admitting syllogisms of weakened conclusion (as *Cesaro* in the second figure) Hospinian

obtains 512 possible moods, of which all but 36 are rejected as either useless or invalid. Some one, I know not who, or how, obtained 9210 moods. This I learn from an old disputation, *de Arte Syllogistica*, held at Leipsic in 1675, in which the young respondent, Christian Ihlius, after alluding to the 512 and the 9210, proceeds thus:—*Verum hi ipsi peccant tum in Deum tum in proximum: in Deum, dum dona concessa tam male impendunt; in proximum, dum ingenia discentium magis onerant quam juvant.*

Leibnitz himself worked out the 912 moods so soon as he saw Hospinian's title-page, and has given his

account of them in the dissertation I have been citing. It is *de Arte Combinatoria*, first published at Leipsic in 1666, when Leibnitz was twenty years old. He approves of Hospinian's syllogisms of weakened conclusion, but attacks his treatment of the singular proposition as particular: *Titio omnes vestes quas habeo do lego, quis dubitet etsi unicam habeam ei deberi?* Wallis had maintained the same in a disputation at Emmanuel College in 1631, being then not sixteen years old. Leibnitz's dissertation *de Arte Combinatoria* must have been written as a university thesis, whether so read or not.

June 25, 1858.

XI. *On the Statue of Solon mentioned by Æschines and Demosthenes.*
By J. W. DONALDSON, D.D., *Vice-President of the Society.*

[Read Feb. 22, 1858.]

It seems to be a special duty of the philosopher, as such, to discover truth wherever it is concealed or misrepresented, and to expose error in whatever province or department it may be found. And although the identification of an ancient statue may appear at first sight to belong to an antiquarian rather than a philosophical society, I hope to be able to prove that the subject, to which I have invited your attention, is one which properly falls within the circle of our investigations as philosophers in general and as philologists in particular. I propose to show the groundlessness and futility of an arbitrary hypothesis, which has for a long time imposed on every student of art and every traveller to Southern Italy, and which has been made the foundation of a still more erroneous statement in the most widely circulated of our English Cyclopædias; to correct a more plausible opinion, maintained or accepted by great artists and scholars; and to lay before you a simple and, as it appears to me, very obvious conclusion, which illustrates two important passages in Demosthenes and Æschines, and revives a recollection of a very early and interesting relic of the history and literature of Athens.

One of the most beautiful and conspicuous statues recovered from the ruins of Herculaneum is exhibited in the *Museo Borbonico* at Naples as a whole length statue of Aristides, the Just, the son of Lysimachus. The reasons for this identification are given as follows by Finati in his splendid publication of the monuments of that museum (*Museo Borbonico*, Vol. I. pl. L): "Non essendovi, per quanto è a nostra notizia, ritratti autentici di Aristide, e non avendo ritrovato alcun rapporto di somiglianza fra questa statua, e le fattezze di altri ritratti di personaggi noti della Grecia, noi abbiamo seguito la commune opinione, chi riconosce effigiato in questa statua il rivale di Temistocle; tanto piu che le fattezze della medesima, l'attitudine, e l'abbigliamento non disconvengono al carattere e alla facondia di Aristide, non che al costume de' tempi suoi."

It is quite needless to point out the invalidity of this reasoning. There is no ground whatever for what Finati calls "the common opinion" that this statue represents Aristides the Just, or indeed any person of that name. It is merely a guess or an assumption. But if Finati's arguments are worthless, still less valuable is the correction of his view by the writer, who gives us the life of Ælius Aristides the rhetorician in the *Penny Cyclopædia*, Vol. I. p. 325, and who introduces a wood-cut of the statue from Herculaneum by way of a portrait of his subject. He says: "From comparing the head with that of Ælius Aristides in the Vatican, and from the somewhat affected attitude, and the general character of the figure, we are convinced it is not the old Aristides. It may be objected by some that this statue is superior as

a work of art to the age to which we have assigned it. This objection may be a good one; and the only conclusion then must be, that we do not know whom it was intended to represent."

This is perhaps the most marvellous piece of criticism to be met with in any language.

(1) Because Finati calls it a statue of Aristides the Just, this is a ground for considering it the statue of some person of that name, which there is no inscription or other evidence to show.

(2) Then since it must be the statue of an Aristides, and as we have a genuine bust of the rhetorician, the slightest amount of resemblance will suffice to identify the two; or rather, a resemblance is asserted without the least foundation in fact. Those who will compare the two faces will see that they are as unlike as possible. Ælius Aristides was partly bald, and had an aquiline nose. This statue has a straight nose, and no appearance of baldness.

(3) The writer is so careless that he cannot inquire when Ælius Aristides was born, and when Herculaneum was destroyed. As the latter event happened in A.D. 79, and as Aristides was not born on the earliest calculation till A.D. 117, it is rather unlikely that an elaborate statue $6\frac{1}{2}$ feet high, representing the rhetorician who was so popular in the following century, would have been preserved among the ruins of that Campanian country-town.

(4) The valid objection to which he adverts, and the naive admission which follows, would have induced most writers to abstain from such a questionable illustration of their subject. But surely this was the more incumbent on the writer in a popular work, in which every error was likely to be stereotyped in the most literal sense and diffused throughout the widest possible circle of readers.

Thus far the task which I have undertaken is singularly easy. It does not require much consideration to see that the opinion maintained by Finati, and first started, I believe, by the Marchese Venuti, that this celebrated statue represents Aristides the son of Lysimachus, is an arbitrary and unfounded conjecture; or to expose the extreme absurdity of the supposition that a grand portrait statue of Ælius Aristides adorned the theatre at Herculaneum some 40 years before his birth. The identification of this statue, however, is a much more difficult undertaking, and has become a very interesting one, not only on account of the rare beauty of the statue as a work of art, but also because it may be made a striking illustration of the oratorical and political warfare between Æschines and Demosthenes.

The first beginning of a rational and scholarlike examination of this statue was made by E. Gerhard in his and Panofka's volume, entitled *Neapels Antike Bildwerke* (Band. I. p. 105, Stuttgart. u. Tübing. 1828). He showed that the identification of the statue with Aristides was very insufficiently established, or rather that it was a mere assumption; that this statue, which, with that of Homer, and one erroneously assigned to Poplicola, probably adorned the theatre of Herculaneum (*Bildwerke*, p. 101), was less strongly marked in the features of the countenance than in the execution of the figure and drapery, and that its identification with any known portrait was therefore more difficult; but that the costume and the truncated *scrinium* rendered it likely that the person represented was an orator or some literary man. As for Aristides the Just, he would have been portrayed in heroic costume, or, like the so-called Phocion of the Vatican, in a military mantle and sword-belt (Visconti, *Mus. Pio-Clement.* II. 43).

From this sound, but merely negative, criticism, a transition was made to positive and decided opinion by Sig. Vescovali, who, being employed in 1835 to direct the restoration of a similar work of art, was led to compare it with that of the supposed Aristides, and eventually he and the sculptor Filippo Gnaccarini recognised the same lineaments in a Hermes or terminal bust inscribed ΑΙΣΧΙΝΗΣ, which is preserved in the Vatican. The professors of the *Accademia di Santo Luca* being consulted agreed as to the perfect resemblance between the two portraits, and this conclusion was strengthened by the high authority of Thorwaldsen (*Bulletino dell' Instituto di Correspondenza Archeologica, Roma, 1835, pp. 47, 48*).

Although K. O. Müller assents to this conclusion (*Ancient Art and its Remains, § 420, R. 6, p. 599, Leitch's translation of the new ed. 1850*), I have no hesitation in rejecting it, for the following reasons:

(1) There is no reason to suppose that a whole-length statue of such a size was ever made in honour of the discarded politician Æschines. Such statues were public works, and presumed a large amount of undisturbed popularity or reputation, such as Æschines never enjoyed.

(2) If there had been such a statue of Æschines, one can hardly conceive that it would have been selected as one of the most prominent ornaments of a theatre in an Italian provincial town. Those, who knew that Æschines had been an actor, were also aware that his early efforts in the histrionic profession were by no means eminent or successful; and that it was always considered a reproach to him rather than an honour to have been a *tritagonist* in his younger days.

(3) Of all the Greek orators Æschines was the least likely to have been represented with a *scrinium* of his writings by his side. He only committed three of his speeches to writing, and the fourth speech, which was attributed to him, was rejected even by the ancients as not genuine (*Plut. Vit. X. Orat. p. 840 E; Philostr. l. 18; Phot. Cod. LXI*). And he is said to have been the inventor of unpremeditated or extempore speaking (*Philostr. Vit. Soph. pp. 482, 509*).

(4) I have compared the bust of the so-called Aristides with all the busts of Æschines which are known (*Millingen, Unedited Monuments, Series II. Plates IX, X, p. 17; Visconti, Iconographie Gr. I. p. 29; British Museum, No. 81*), and though I recognise a certain amount of general resemblance, I must say, with all deference to the distinguished artists who have come to a different conclusion, that I see also strong marks of difference in the measurements of the faces, and I am supported by the opinion of Gerhard in my belief that the head of the so-called Aristides is not a portrait, in the proper sense of the term, namely, the copy of some living face, but rather an ideal or imaginary personification.

(5) If the face were more like the bust of Æschines than I can perceive it to be, the figure undoubtedly is not his. We have here a noble person of commanding stature; but Æschines must have been a conspicuously diminutive and insignificant person, otherwise the taunts of his great adversary would have no point. Demosthenes, in the presence of all the Athenians, who could easily see or well knew whether it was not a true description, called Æschines "the pretty image" (*τὸν καλὸν ἀνδριάντα, de Corona, p. 270, 11*), where the epithet *καλός*, like the name of *καλός*, or *καλλίας*, given to the ape, and *pulcino* or *pulcinello* applied to the puppet "Punch," of itself implies the notion of "a pretty little fellow" (see *Theatre of*

the Greeks, Ed. 6, p. 160). Then again Demosthenes draws a ludicrous picture of Æschines stalking across the market-place with his outer garment down to his ankles (not held up as in this statue), and keeping step with the tall Pythocles, "puffing out his cheeks, and one of Philip's friends, if any one is" (*de falsa Legat.* p. 442, 15), a picture, which would not be half so absurd, if Æschines had been naturally the stately personage represented in this statue. Finally, Ulpian tells us expressly (*ad Orat. de Corona*, l. l.), wherever he learned it, that Æschines was known to be a little man.

Much, therefore, as I respect those who have identified our statue with the orator Æschines, I cannot but regard these reasons as decisive against their opinion, especially as that opinion is mainly supported by a mistaken reference to Æschines of the passages by which alone, as I conceive, we can fix upon the person represented by this noble figure. In the report of Vescovali's discovery (*Bullet.* p. 48), it is expressly said: "dottissimo e veramente degno di simile scoperta fu poi il divisamento, che prese l'autore di mostrare come non solamente i tratti della testa, ma anzi tutto l'insieme di ridetta statua d'Aristide convenisse alla denominazione d'Eschine, il di cui singolare ma significante atteggiamento, cioè di tener le mani dentro il manto, come lo vediamo nella celebre statua di Napoli, derise assai volte il suo grande avversario, lo stesso Demostene."

It detracts seriously from the weight which we might be disposed to attach to Vescovali's other reasons, when we find his supposed discovery supported by such a palpable error. There is not the slightest foundation for the statement that Æschines was derided by Demosthenes for a posture similar to that of the statue before us, and the well-known passages, to which a reference is tacitly made, expressly attribute that "singular but significant attitude" to a person with whom he is scornfully contrasted. To these passages I must now invite your attention.

In his speech against Timarchus, in which his charge of profligacy is sustained by an appeal to the notorious character of his political opponent and without producing any direct evidence (hence *ἀμαρτύρους ἀργῶνας* in the taunt of Demosthenes, *de fals. Leg.* p. 378), Æschines endeavours to strengthen the general prejudice against his political antagonist by contrasting the decorous oratory, which he attributes to the older statesmen of Athens, with the negligent deshabelle in which Timarchus had once appeared on the bema. He says (p. 4): "So modest were those ancient orators, Pericles, Themistocles, and Aristides, who was called *the Just*, a surname very different from that of the defendant Timarchus, that they regarded as somewhat bold and were afraid to do that, which now-a-days all of us are in the habit of doing, namely, speaking with outstretched hand (*τὸ τὴν χεῖρα ἔξω ἔχοντες λέγειν*). And I think that I can exhibit to you in visible reality (*ἔργῳ*) a very remarkable proof of this. For I know well that you have made a trip to Salamis and have seen the statue of Solon, and would testify yourselves that Solon is represented in the forum of the Salaminians with his hand in his robe (*ἐντὸς τὴν χεῖρα ἔχων*). This, men of Athens, is a memorial and imitation of the posture in which Solon discoursed to the Athenian people. But consider, sirs, how greatly Solon and those, whom I have just mentioned, differ from Timarchus. For they were ashamed to speak with outstretched hand. Timarchus, on the contrary, not long ago, quite recently, having cast aside his robe (*ιμάτιον*), flung about his bare arms like an athlete (*γυμνὸς ἐπαγ-*

κρατίαζεν) in the assembly, being in such a bad and unseemly habit of body through his drunkenness and abominations that men of sense covered their eyes, being ashamed for the city's sake that we employ such advisers."

In this passage you will observe that Æschines expressly includes himself in the number of those who adopted the ordinary custom of speaking with outstretched hand, and that he attributes the contrary practice to the older orators, merely on the strength of the Salaminian statue of Solon, which, as we shall see, was at that time a modern work of art. When he says ὁ νυνὶ πάντες ἐν ἔθει πράττομεν, it appears to me eminently absurd to claim him as the subject of a statue, which exhibits the contrasted posture.

The prosecution and ruin of Timarchus took place in B.C. 345 and caused some delay in the intended attack on Æschines. But in August or September 343, the cause of the Embassy came on, and Demosthenes in his great speech on that occasion makes many references to the impeachment of his unhappy colleague. He adverts very emphatically to the passage about Solon's statue which I have just read, and turns it against Æschines with his usual dexterity. "Come now," he exclaims (*de fals. Legat.* p. 420, § 281), "consider what he said about Solon. For he observed that Solon was represented as an example of the modesty of former orators, having his mantle flung about him with his hand inside (εἶσω τὴν χεῖρα ἔχοντα ἀναβεβλημένον), and this by way of reproaching and reviling the inconsiderateness of Timarchus. And yet the Salaminians say that this statue has not yet been set up 50 years, whereas it is nearly 240 years from Solon to the present time, so that the artist who modelled that figure was not a contemporary of Solon, no, not even his grandfather was. However he said this to the jury, and imitated the posture" (*i. e.* on this occasion only: the verbs are aorists, εἶπεν and ἐμιμήσατο). "But what was far more advantageous to the state than this attitude—namely, to see the soul and mind of Solon—of this he gave no imitation, but quite the contrary." And then he proceeds to contrast the conduct of Solon, who put on a cap (πιλίον περιθέμενος, *Plut. Solon*, 8), an outward mark of illness, and feigned insanity for a patriotic object, namely, to induce the Athenians to renew their attempts on Salamis, with the conduct of Æschines, who put on a cap (πιλίδιον) and shammed sickness in order to evade a public duty (*de fals. Leg.* p. 379, § 136). Demosthenes concludes the passage as follows (p. 421, § 285): "The necessary point, Æschines, is not to make speeches with your hand inside your mantle—no, not that—but to keep your hand inside when you go on an embassy. But you, having extended it and held it open there and disgracing your countrymen, make pompous speeches here, and having learned by heart and spouted some miserable phrases imagine that you will not pay the penalty for such great and numerous crimes, if you only walk about with a little cap on your head, and revile me."

This passage properly examined will, I think, lead us to the inevitable conclusion that the statue under consideration is a good copy of the famous Salaminian whole-length of the legislator Solon, who had reunited Salamis with Athens.

You will have observed that according to Demosthenes that statue had been erected less than 50 years before B.C. 343, *i. e.* somewhere about B.C. 390. This was an epoch in the history of Greek sculpture. It was towards the beginning of the period rendered illustrious by the names of Scopas and Praxiteles. And whatever doubt may be entertained as to the

authorship of the celebrated group of Niobe, which the ancients attributed to one or other of these founders of the later Athenian school (Plin. *H. N.* xxxvi. 5, § 28), there is every reason to believe that Scopas must have been employed both to make the marble statue of Solon, which the Athenians had erected in the forum of Salamis, even if he did not design the bronze statue of the same person which had been set up, apparently about the same time, before the Pœcile Stoa (Pausan. i. 16, § 1; Ælian, *V. H.* viii. 16) in the forum at Athens (Pseudo-Demosth. *c. Aristog.* ii. p. 807, § 27). The passage in Pliny, which mentions Scopas among the workers in bronze (*H. N.* xxxiv. § 90 Sillig), is undoubtedly corrupt, and I should propose to read for *philosophos Scopas uterque* the words *philosophos poetasque*. But although Scopas generally took his subjects from mythology there is no doubt that he made statues of human beings also. Horace, who must have seen many of his works, speaks of him as (iv. *Carm.* 8, 8):

Sollers nunc hominem ponere, nunc deum.

And a dedicatory statue of Solon would possess enough of the ideal to gratify his taste. That the statue before us was quite in his style may easily be shown. The Apollo Citharœdus, in the Pio-Clementine Museum, which is known to be a copy of the Palatine Apollo of Scopas (Plin. *H. N.* xxxvi. 5, § 25), is thus described by Propertius (ii. 31, 11):

Pythius in longa carmina veste sonat:

and exhibits precisely the same characteristics in the elaborate treatment of the drapery. Indeed I do not know any ancient statues in which the folds of a robe and tunic are more carefully given than in the Palatine Apollo and this statue, as I suppose, of Solon. The Mœnad, which was undoubtedly a work of Scopas (Müller, *Denkm. d. alt. Kunst*, No. 140), shows in a lesser degree the same skill in this department, and we have further exemplifications of it in the group of Niobe, whether that was the work of Scopas or of Praxiteles (Müller, *Arch.* § 126, p. 1; Welcker, *alte Denkmäler*, i. pp. 218 sqq.). I incline with Schlegel and Gerhard to the belief that this master-piece of Greek sculpture was due to the chisel of Scopas, and, if so, we may compare the sandals of our figure with those on the feet of the youngest son of Niobe.

But whether Scopas was or was not the sculptor of the Salaminian statue of Solon, it is easy to show that the costume of the statue before us is that which is especially characteristic of the most elegant and cultivated Athenians at the very period when, according to Demosthenes, the statue of Solon was erected. The orator describes the figure as *ἀναβεβλημένος*, that is, with the *μάτιον* or mantle wrapped around it. "The himation," says Müller (*Arch.* § 337), "was a large square garment, generally drawn round from the left arm, which held it fast, across the back, and then over the right arm, or else through, beneath it, towards the left arm. The good-breeding of the free-born, and the manifold characters of life were recognised, still more than in the girding of the *chiton*, by the mode of wearing the *himation*." Hence, as Athenæus tells us (i. p. 21 B): "the ancients took great pains about gathering up (*ἀναλαμβάνειν*) their clothes in an elegant manner, and ridiculed those who neglected to do this," and he cites a remarkable passage from the *Theætetus* of Plato, written about the time when Solon's statue was set up, in which the illiterate and vulgar-minded pettifogger is described as "not knowing how to put on his mantle to the right-about like a gentleman" (*ἀναβάλλεσθαι οὐκ*

ἐπιστάμενος ἐπὶ δέξια ἐλευθερίως, p. 175 E). This distinction between the well-bred man and the vulgarian had been acknowledged for some time at Athens, as is shown by a very comical passage in the *Birds* of Aristophanes, which was acted in B.C. 414. A deputation, consisting of two civilised gods and one barbarian deity, waits upon Peisthetærus to negotiate about the blockade of heaven by the feathered citizens of *Nephelococcygia*, and Neptune, who is ashamed of the costume and bearing of his Mæsiian colleague, addresses him thus before the interview commences: "I say, you sir, what are you about? do you wear your mantle in that way to the left-about? Change it at once to the right-about. You miserable creature, what a true Læspodias you are!" (*Aves*, 1566—9):

οὗτος τί δρᾶς; ἐπ' ἀριστέρ' οὕτως ἀμπέχει;
οὐ μεταβαλεῖς θοιμάτιον ὧδ' ἐπὶ δεξιάν;
τί, ὦ κακόδαιμον; Λαισποδίας εἶ τὴν φύσιν.

But it was not only required that the mantle should be correctly adjusted as far as the arms were concerned; it was necessary to decorum in the highest class of persons that it should hang down nearly to the instep. Quintilian says (*I. O.* xi. 3, § 143): "togam veteres ad calceos usque demittebant ut Græci pallium." And as this implied an ἐπίβλημα or ἀναβολή of greater size, we find that an ampler *pallium* or *abolla* was regarded as a mark of the sedate and dignified philosopher—in fact, as a sort of Doctor's gown. Juvenal says (*III.* 114, 5):

Et quoniam cœpit Græcorum mentio transi
Gymnasia, atque audi facinus majoris abollæ.

In this *major abolla*, with the mode of envelopment peculiar to the age of Plato and Scopas, and with the peculiar posture of the hand, which marked the statue of the philosophical legislator Solon, the noble figure of the *Museo Borbonico* stands before us. And it is, as I conceive, sufficiently identified by these distinctive features with the Salaminian memorial of which Æschines and Demosthenes make such emphatic mention. That there was no extant portrait of Solon, and that the head which was assigned to him at the beginning of the 4th century B.C. was merely ideal or heroic, it is quite unnecessary to prove. And therefore I do not enter into the question whether the countenance is or is not like other imaginary heads of the legislator. There is a two-headed Hermes of Solon and Euripides, both connected with Salamis, in the Pio-Clementine Museum (*VI.* pp. 79, 80), and Visconti has published (*Iconogr. Gr.* i. pl. ix. p. 108) a bust preserved in the gallery at Florence, with a ribband round the head as a symbol of Apotheosis, and with the inscription: COΛΩΝ Ο ΝΟΜΟΘΗΤΗΣ. These two busts do not correspond in features, and therefore no argument can be drawn from the want of resemblance between either of them and a third head.

It only remains that I should remark on the suitability of a statue of Solon to the place in which this noble figure was found, namely, along with that of Homer, as an ornament of the theatre at Herculaneum.

Solon was not only a legislator. He was one of the chief of the elegiac poets of Greece, and his verses exercised a marked influence on the style of the dramatists (*Theatre of the Greeks*, p. 79). I do not, of course, suppose that either the architect or the stage-manager of the theatre at Herculaneum had any profound or critical reasons for connecting Solon with the stage. It

was no doubt sufficient for them that he was an eminent Greek sage and poet, and that he was forthcoming in a first-rate statue. The excellence of this figure, as a work of art, is just the reason why copies of it would be multiplied, and there was nothing in the circumstances of Herculanum to prevent the people of this town from securing, as we see they did secure, Greek sculpture of rare excellence and value. Next to Neapolis and Capua it seems that this old city was the most considerable place in Campania. Its population had at one time been principally Hellenic, and it had afterwards become a Colonia. The dimensions of the amphitheatre provide for a large population, and the elaborate pictures and statues, to say nothing of the literary remains, indicate an exalted condition of cultivation and refinement. There was nothing then to prevent the inhabitants of Herculanum from acquiring the best copy that could be procured of the best statue in Greece, and we see in this particular case that they succeeded in obtaining a work of art which, in the absence of the original, must be regarded as one of the finest draped figures that have proceeded from the studio of a Greek sculptor.

The question has now been considered from all sides. We have seen that the statue before us possesses the characteristics of the age at which the Salaminian effigy was erected, and that the costume represents the mode of wearing the mantle which was the characteristic mark of a well-born and well-bred Athenian at that particular epoch: while the attitude is so distinctive that Æschines and Demosthenes made the statue which exhibited it, the suggestive topic of their invectives and arguments. Accordingly, as the style of the statue fixes it to this particular time, the use made of the statue by the two great orators renders it tolerably certain that no other figure in such a posture was then generally known. And if it is said that the same attitude might have been adopted by sculptors for other portrait statues subsequent to the time of Æschines, there is a simple answer to this. The excellence of the work indicates a first-rate artist, and such an artist would not have been beholden to a predecessor for the main features of his design. We know indeed from a speech delivered by Dion Chrysostomus, not very long after the destruction of Herculanum (*Rhodiaca Oratio*, xxxi.), that a practice had grown up at Rhodes of altering the inscriptions of public statues, especially bronzes, and making them serve as representations of other personages, whom it had been decreed to honour in this way: ὁ γὰρ στρατηγὸς ὃν ἂν αὐτῷ φανῆ τῶν ἀνακειμένων τούτων ἀνδριάντων ἀποδείκνυσιν εἶτα τῆς μὲν πρότερον οὔσης ἐπιγραφῆς ἀναιρεθείσης, ἑτέρου δ' ὀνόματος ἐγχαραχθέντος, πέρας ἔχει τὸ τῆς τιμῆς (p. 569 R, p. 346 Dindorf). But then this practice was probably confined to Rhodes, where there was a superabundance of these honorary statues, and the strong arguments of Dion would probably put a stop to the imposition even in that island. Besides, the orator tells us that the Rhodians did not change the inscriptions of well-known and distinguishable statues (p. 607 R, p. 370 Dindorf), of those which were defined not only by the name but by the characteristics (χαρακτήρ) of the person represented (p. 591 R, p. 360 Dindorf), but only made this bad use of the undistinguishable and very old figures (ἀσήμοις καὶ σφόδρα παλαιοῖς καταχρῶνται, p. 370, l. 8, Dindorf). Now these particulars would except the statue before us, if it were that of Solon, from any such malversation even at Rhodes, where Æschines would have had a statue, if he obtained such an honour anywhere; for he was the founder of a school of rhetoric there. And the notoriety of the statue at Salamis, and the circulation which he would give to his own writings, would be its guarantee against any appropriation

of it by that some-time orator turned into a rhetorician. It is indeed most unreasonable to suppose that Æschines or his friends would lay claim to a statue, which the writings of that orator, wherever they were known, would indicate as belonging to Solon, and the excellence of the design and workmanship show that no such plagiarism or piracy was committed in a later age.

On these grounds, I conclude, with as much confidence as I can feel in such a case, that the draped figure of the *Museo Borbonico*, which has attracted so much notice by its artistic beauty, is an excellent representative of the celebrated Salaminian statue of Solon, which is mentioned so emphatically by Æschines and Demosthenes. Indeed I may say that from the moment when I first became acquainted with that statue and compared it with the passages I have cited, its identification by means of its peculiar attitude suggested itself to me as obvious and inevitable. And I hope that no one will consider this an unimportant result because it is an almost self-evident conclusion, when it is properly indicated. We have seen how scholars and artists have misled one another on this point. And when we reflect that man, by the very constitution of his nature, connects his future hopes with the firmness of his belief in the history of the past, we must always prize the tangible proofs which are furnished by monumental or documentary evidence. It is not therefore unimportant that we should be able to recognise, among the spoils of time rescued from the ruins of Herculaneum, the figure which the Athenians, in the days of their greatest orators, had often seen in the market-place of Salamis, and which stood there as a commemoration at once of their great lawgiver and poet, and of the reconquest of that glorious island, without which, as a place of refuge for their wives and children, they could hardly have fought and won the great sea fight for the liberty of Hellas.

XII. *Instances of remarkable Abnormities in the Voluntary Muscles.* By G. E. PAGET, M.D., F.R.C.P., *late Fellow of Gonville and Caius College.*

[Read March 8, 1858.]

THE rarity of such cases as the following induces me to communicate them to the Society.

Joseph D., 10 years of age, son of an agricultural labourer at S., a village near Ely, was admitted into Addenbrooke's Hospital, June 3, 1857. In stature and general bulk he was a little below boys of the same age. He was not strikingly deformed, nor was there any want of symmetry between his right and left sides. Yet he appeared ill-shaped and clumsy, and even at first sight his figure was observed to be very peculiar, and his movements still more so. In walking he carried himself in a strangely awkward manner, throwing his shoulders very far back, and advancing his belly like a corpulent man: he walked flat-footed and waddling, the whole side of his body being moved with evident effort at the advance of each leg, the feet being raised higher, and knees more bent than is usual in well-made persons. He could not run: when he attempted it, his movements were only a clumsy and feeble acceleration of his walking gait, with all its awkwardnesses exaggerated.

He often fell from slight causes, or without any obvious cause; and when on the ground was unable to rise: he was obliged to lie there until somebody raised him. When replaced on his feet he was very liable to fall again, through a defect in the power of balancing himself in an erect posture. He fell heavily and helplessly in any direction to which his body might happen to incline, forwards, backwards or sideways, and often struck his forehead or occiput against the ground.

He was unable to get up a low step, such as that at the door of the Hospital, without making use of his hands, and even with their assistance he had much difficulty in accomplishing it. His mode of proceeding was this:—He first laid hold of the right door-stall with both hands: and thus supporting himself, he swung round his left leg outwards and forwards, so as to get that part on the step. He then, with a laborious effort, dragged his right foot after him.

He was unable to get into bed without the assistance of others.

To get *down* a step (though only a few inches in height), he went backwards, as a man goes down a ladder.

When standing still, his spine, in dorsal as well as lumbar region, was bent with its convexity forwards; his shoulders were drawn far back; his knees were turned inwards and projected forwards. When seated, his whole spine was uniformly bent with its convexity backwards, as frequently seen in children that are weakly or fatigued.

On examining him carefully with the view of discovering the immediate cause of his weakness and infirmities, I found no defect, disease or deformity of the bones. The defects and

other abnormalities were apparent only in the muscular system. The most striking defect was in the muscles by which the arms are united to the trunk, viz. the two pectoral muscles and the *latissimus dorsi*. Of the *pectoralis major* a small band could be made out, but so meagre was its volume as not to be perceptible except when his arm was extended laterally. This small band had its origin from the clavicle, and therefore represented only the upper part of the great pectoral muscle; its lower or sternal and costal portions being wholly absent. The anterior boundary of the axilla was therefore very defective, the fold of skin, containing the small representative of the pectoral muscle, forming a barely visible projection; and the posterior boundary was equally defective, through the smallness of the *latissimus dorsi*, so that the axilla presented scarcely any cavity or hollow whatever. Of the lesser pectoral muscle not the least trace was discernible. The defects on both right and left sides were the same.

One strange consequence resulted from the deficiency in the bulk and tone of these muscles. It was not possible, by putting one's hands under his armpits, to raise him from the ground, as is so easily done with children in general. When the attempt was made, his shoulders were lifted up, as if they had scarcely any connexion, or at most only a passive and very loose one, with the thorax: there seemed no resistance, except from the mere weight of the arms.

Another consequence of the defective condition of the pectoral muscles was, that, when he was desired to draw a deep breath, the upper part of his thorax was not perceptibly elevated, though its lower and lateral parts were largely raised by the effort.

The *serratus magnus* was very deficient in bulk, and the *trapezius* somewhat meagre. So likewise were the muscles of the upper arm, with the exception of the deltoid which was of normal dimensions.

On the contrary, the muscles of the forearms were larger and firmer than usual in a boy of his age, and in these respects contrasted strongly with those covering the humerus—the biceps, brachialis anticus and triceps—which were both small and flabby.

The maximum girths of these parts were:

Right upper arm 6 inches: forearm 7 inches.

Left ————— 7 ———: ——— $6\frac{7}{8}$ ———

The nates were very large and prominent, and appeared more strikingly so through the bending in of his back. The thighs were somewhat small in their upper part. The knees of ordinary size; the ankles small and well-formed. The calves on the contrary were so enormously large, as to appear strangely unsuitable to the rest of his figure. They appeared larger in proportion than I ever saw them in any individual. They seemed larger, in proportion to the length of his leg, than in the stoutest porter or the Farnese Hercules*. They were so incongruously large as to appear really ludicrous, and they were as firm as the sole of a shoe, presenting in this respect a striking contrast to those muscles which have been mentioned as deficient in bulk, all of which were soft and flaccid.

The maximum girth of each thigh was $11\frac{1}{2}$ inches.

The girth of each leg between calf and patella was 9 inches.

* I have found this to be the fact—the maximum girth of the calf in the Farnese Hercules bearing a proportion to the length of the leg of 10 to 11.

The maximum girth of the calves :—right 11 in., left $11\frac{1}{4}$ in.

The girth of ankle $6\frac{1}{2}$ inches.

The length of leg from upper end of tibia to the sole of the foot was 12 inches.

The enormous development of the calf is the more remarkable as the boy wore the highlows so common among our agricultural labourers, in which thick soles, rigid upper-leathers and tight lacing combine to prevent free movements of the ankle-joint and toes.

It is probable that there were other defects in his muscular system, which (being more deeply seated) could not be clearly made out by an external examination. The defects that have been particularly described seem inadequate to account for all his failures in locomotion, such as his want of power to lift up his feet so as to ascend a step in the ordinary way, and his inability to get up when lying on the floor. In both these cases the immediate cause seemed to be that he was unable to draw well forward, or flex, his thighs on the trunk. This may have been a consequence of feebleness or absence of the psoas and iliacus muscles, but I could not discern such a want of fulness in the groins as to make me sure that these muscles, or either of them, were absent or very imperfect, like the pectoral muscles.

If he leaned forward, resting with his hands on a table, he was quite unable to recover the erect posture. This seemed to indicate a deficiency in the extensor muscles of his spine; but the chief failing must rather have been in his legs; for, in making the effort to recover the upright position, his knees became bent;—and when this was prevented by firmly supporting his legs, he was enabled, though with difficulty and effort, to regain the erect posture. The muscular masses situated along either side of the spine seemed sufficiently developed, as far as they could be judged of by external appearances, for the mid line, in which the spinous processes lie, was marked by the usual longitudinal depression.

From his mother's statement it appeared that the defects dated from his earliest infancy, and were probably congenital. Even when a child at the breast he had a tendency to fall backwards: he was also weakly, and could not sit up in her arms like a healthy child. His bowels were relaxed and irritable, so that ingestion of food was quickly followed by an evacuation, and this lientery had not ceased until twelve months before his coming to the Hospital. He was unable to walk until 2 years old, and even then had the tendency to fall, under which he has ever since laboured, often falling forwards on his forehead, never saving himself or breaking his fall, but not losing consciousness.

His calves began to enlarge when he began to walk: before that time they were not of immoderate size.

He is extraordinarily wilful, obstinate and ill-behaved; but it is probable that this is merely the consequence of ill-judged indulgence by his parents, through pity for his physical infirmities. His education has been wholly neglected:—he was not sent to school, because other boys in the village amused themselves by pushing him down, and leaving him on the ground unable to rise.

While he was in the Hospital his general health was good, pulse 96, bowels regular, appetite hearty. He ate the full diet of an adult patient. He improved a little, but only a little, in strength and power of locomotion.

A brother, Thomas D., aged 9, was admitted into the Hospital at the same time, labouring

under defects and peculiarities of a precisely similar kind, differing only in degree. The peculiarities and defects of the younger brother were much less in degree, and he derived more benefit from his stay in the Hospital, improving considerably in power and readiness of movement, and becoming capable of rising from the ground without assistance, whenever he happened to fall. In temper and bad manners also he resembled his brother, but had these failings in a less degree, and was more amenable to discipline and less insensible to kindness. He had likewise had the lientery—indeed up to the time of his admission to the Hospital. Both the cases were treated with Cinchona, full diet, air and exercise.

Their parents have three other children living, viz. a son aged 19, a daughter aged 7, and an infant in arms. Only Joseph and Thomas have any personal defect. During their mother's pregnancy with these two she was living (where she lived many years) in a damp, malarious locality near some clay-pits by the bank of the New Bedford River. She had ague several times; she had it during these two pregnancies; and during the last three months of each she also suffered from pains darting from pubes to sacrum and down the front of her left thigh; and the limb was paralytic, so that she dragged it in walking. She has had no such symptoms in her other pregnancies; and on the two occasions on which they did occur, they ceased at the time of her delivery. Between her eldest son and Joseph she had four children, all of whom are dead; the first of them died, when 2 years old, of Chronic Hydrocephalus, and the third died in fits. The father is hearty and strong: the mother is well-made, and not of nervous temperament; but a sister of hers has a child 7 years old, which, as I am informed, has never been able to stand, and until lately has been unable to articulate.

The abnormalities in the muscular systems of these boys are remarkable in occurring symmetrically on the two sides. They are remarkable in not being associated with any manifest deformity of the bones. Another notable peculiarity is that they are of two different, indeed opposite, kinds;—some of them characterised by defect, and others by excess of muscular development.

In speculating as to their cause, the first question is whether they were congenital, or the result of changes in muscles that had been well-constituted at birth. With regard to the deficiencies, it can scarcely be doubted that they were congenital. This is the natural inference to be drawn from the mother's statement. But can the same be said of the abnormalities characterised by excess? I think not.

Prima facie, it is improbable that during foetal life one part of the muscular system should fall short of its normal development, and another go beyond it: and in the next place we have the evidence of the boy's mother, who says that his calves were not of disproportionate magnitude before he began to walk. We are therefore led to separate the abnormalities into two classes, viz. those which were congenital, and those which had their origin after birth;—and these have opposite characteristics, the muscles being deficient in the former and unnaturally large in the latter class.

Are these very dissimilar abnormalities related to one another; and if so, what is the nature of their relation?

I am inclined to think they stand to one another in a very close relation—that of cause and effect. It is easily intelligible how a primary defect in the muscles of the upper arm and

shoulder may tend to augment the size and tone of those of the forearm by throwing upon them an unusual share of labour. A greater exertion of the muscles of the forearm is made to compensate for the defective strength and activity of the upper arm; and the former are therefore augmented by the operation of the well-known law of the nutrition of muscles.

Similar remarks would apply to the thigh and leg. The want of vigour in the thighs would probably lead in a variety of ways to increased exertion in the muscles of the calves, and therefore to an augmentation in their bulk, but I think the most potent cause of the enormous development of the calves was the boy's peculiar carriage.

In walking, his shoulders were drawn very far back, and the whole trunk leaned backwards. This would have the effect of throwing the centre of gravity further back than is usual, so that a vertical line through it would fall nearer to the heel, and further from the toes, than is consistent with easy walking. As progression is mainly effected by the muscles of the calf—raising the heel so as to throw forward the centre of gravity, which turns round the ball of the foot, or toes, as a fulcrum—the effort required must be greater, if the body be so carried that a vertical through its centre of gravity falls too far back. Increased labour would thus be thrown on these muscles, and their bulk would in course of time be proportionally augmented.

The throwing back of the shoulders seems a natural consequence of the defect in the pectoral muscles, causing them to yield to the greater tonic power of their antagonists: and in fact the scapulæ were drawn very closely together, their posterior costæ being remarkably approximated. The leaning backwards of the trunk may have been due partly to this drawing back of the shoulders, and partly to the feebleness of the psoas and iliac muscles, which revealed itself in another way through the feebleness of his efforts to flex his thighs upon the trunk.

If these explanations be correct, the deficiency in the pectoral muscles (or in the pectoral, psoas and iliac muscles), occasioning the peculiar carriage of the shoulders and trunk, must be regarded as the primary cause of the enormous enlargement of the gastrocnemius and soleus.

The boys were removed from the Hospital on Sept. 6th: their mother being disappointed at the small improvement in their condition. I have recently heard (after an interval of five months) that the younger boy remains in the same state, but that the elder is certainly feebler than he was when he quitted the Hospital.

I am not aware that any precisely parallel case is on record; but I am able to cite a few which present a portion of the same features. Mr Quain mentions having observed, in the dissection of a body, that the lower half of the costal portion of the larger pectoral muscle was wanting, so that the smaller pectoral lay exposed to a considerable extent after the integuments had been removed*.

A more remarkable case is published by Mr Alfred Poland, in the 6th volume of *Guy's Hospital Reports*. The defect was discovered in dissecting the body of a man, of whom no history could be obtained, except his being a convict, and that it had been remarked that he could never draw his left arm across his chest: when asked to give his left hand, in order that his pulse might be felt by anyone standing on his right side, he invariably turned round to do

* *Anatomy of the Arteries of the Human Body*, by Richard Quain, 1844, page 233.

so. The whole of the sternal and costal portions of the left pectoralis major muscle were deficient; but its clavicular origin quite normal. The pectoralis minor was wholly absent; not a vestige of it to be seen. The serratus magnus muscle was also for the most part deficient, its two superior digitations only being present. The thoracic vessels were present, but very small, supplying the intercostal spaces. The anterior and middle thoracic nerves from the axillary plexus were not found; but the posterior, or respiratory of Sir Charles Bell, was present, and distributed to that portion of the serratus magnus muscle which existed. In the left hand the middle phalanges were absent in all the fingers; except in the middle finger, where a ring of bone, a quarter of an inch in length, supplied its place. The web between the four fingers extended to the first phalangean articulation; so that only one phalanx remained free on the distal extremity of each finger. In this case it will be observed the defects were not strictly limited to the muscular system.

I am indebted to my brother, Mr James Paget, for the particulars of another case, about which he was consulted not long ago. The muscular defects resemble those of Mr Poland's subject. My brother's patient is 15 years old, son of healthy and well-formed parents. He is tall, lean, slim, but strong-limbed and in all respects well-formed everywhere, except on the right side of his chest. Here, without any defect of the skeleton, there is a complete absence of the sternal part of the pectoralis major, of the whole pectoralis minor, and of the serratus magnus. No deformity attends the defect, except that the right side of the chest looks thin, bare and very lean; and the inferior angle of the scapula projects backwards. All the other muscles connected with the chest and with the scapula are well-developed, the deltoid remarkably so. The movements of the right arm are as strong and free as those of the left, with one exception—that, namely, of drawing the arm across the front of the chest, as in folding the arms or in clasping. This movement is comparatively weak: but the strength of the deltoid seems enough to compensate for all the other movements usually performed by the muscles that are here wanting. The integuments and all the other structures in the seat of the defect appear quite healthy. The defect was congenital.

It will be observed that in the last three cases the muscular defect occurred on one side only: in my own cases the defect occurred symmetrically on both sides.

All the cases which I have thus related illustrate the very interesting and suggestive fact, that varieties in muscles are most frequent in parts of which the office is different in different animals—as in the pectoral muscles, which serve for climbing, burrowing, flying, or swimming*.

My brother has suggested to me that these cases have additional importance in the fact that they probably exemplify the simple and *primary* defect of muscles, and herein concur with many recently ascertained facts in shewing that muscles are much more often primarily affected with disease and defect than has hitherto been supposed. He thinks that it has been too common to regard all affections of muscles as secondary to those of their nerves. This is a subject of much interest and importance, and any evidence bearing upon it must be valued accordingly; but the evidence can be only of the probable kind in cases in which we have no means of ascertaining with certainty whether the nerves are, or are not, defective.

* McWhinnie *On the Varieties in the Muscular System of the Human Body*.—Medical Gazette, Jan. 30, 1846.

Since the above was written, my brother has sent me the particulars of another case which he has seen in the last few days, and which in many respects has a striking similarity to my own. The following are his notes: "B. B., now 9 years old, tall and very slim like both his parents. All his muscles, except those of the legs, appeared very small: but especially the pectorales and latissimi dorsi were so, and the borders of his axillæ felt quite unnaturally thin and weak. He walked and ran with his loins extremely hollowed, and his belly projected; he shuffled in walking, and easily broke into a run, and was apt to fall on slight occasions. Through inability to raise his thighs he could not walk up stairs: and when he was laid flat on his back, he could rise only by turning over on his side, and then getting up on hands and knees—something like as a horse does. His defect in the movements of the thighs was as if he had no psoas muscles; but I could not be sure of their absence, though they certainly were very small. His thighs were as lank and weak as any other part of him; but his legs, and especially the calves, were as large, firm and muscular as those of one of the very strongest boys of his age. When he stood erect there appeared a very slight curvature of the lumbar spine to the right; and when he stooped this became much more marked, and was accompanied with an uprising of the soft parts at the right side of the curvature, as if the right sides of the vertebræ in this region were rotated backwards. No other distortion appeared in any part.

"No cause of the defective state of the muscles could, in this case, be assigned. The parents of the patient are wealthy and in good station: they are both well-formed, but have delicate health; and some of the mother's family have been phthisical."

There was no earlier notice of the defects than that the boy, from the first, had an awkward gait.

It is unnecessary to indicate all the points of resemblance between this case and the two which have fallen under my own observation: but it puts beyond a doubt the reality of a relation between the extraordinary development of the calves and the muscular deficiencies elsewhere.

It may be worthy of observation that no deformity of the chest existed in any of these cases. Rokitansky*, and with him many orthopædists, have referred chicken-breast (*Pectus carinatum*) to atrophy or paralysis of the Pectorales and Serrati muscles. The cases here related prove that whatever may be the influence of defect of these muscles, in occasioning the deformity, when the bony and cartilaginous walls of the chest are unsound, the same deformity will not ensue if the skeleton be sound, even though the muscles may be wholly wanting.

We cannot penetrate very deeply into the Pathology of these cases. Our materials are too scanty †. In the two boys who came under my own notice, it seems reasonable to conjecture that the state of the mother's health during gestation was the primary cause of the muscular defects in her offspring. There is reason for this in the fact of her having had on these two occasions (and on these only of her numerous pregnancies) a state of bodily disorder, which manifested itself by definite and peculiar symptoms. But admitting the mother's ill-health to

* *Pathologische Anatomie*, B. II. p. 291.

† I can find on record no other such case of Congenital defect of muscles; nor is any known to Professor W. Vrolik

of Amsterdam, the author of the most complete work on malformations that has yet been published.

have been the primary cause, we are still far from being able to supply the links of causation which would connect it with so peculiar an effect ; and we shall probably in vain seek for them in the obscurities of fœtal pathology.

If we were allowed so far to disregard the statements of the parents—or so far to doubt the accuracy of their observation—as to suppose the muscular defects not to have been really congenital, but the effect of atrophy of limited groups of muscles, commencing in infancy or early childhood, and leaving these strange defects as its permanent result—then the cases I have related would not stand alone. They might be classed with some of those interesting observations, published in recent years, of groups of the voluntary muscles becoming attenuated to an extreme degree, though all the ordinary, well-known causes of muscular atrophy were absent. In two of these examples published by Dr Reade* of Belfast and Dr Brittan† the atrophy was confined to the muscles of the neck, shoulders and upper arms ; and these were reduced to the most abject degree of emaciation, while the forearms and hands displayed the full development of a robust and vigorous man ; and I have myself observed the atrophy limited to the upper arms and thighs in a man‡ aged 25, in whom the disease has been in progress seven years. These resemblances in peculiar features must indicate some analogy in pathological conditions, the reality of which I cannot doubt, even though in one set of cases the muscular defects be congenital, and in the others be the effect of disease in adult life.

* *Dublin Quarterly Journal of Medical Science*, Nov. 1856.

† *British Medical Journal*, Ranking's Abstract, June, 1857.

‡ This man has a brother aged 20, in whom the disease

has been in progress four years :—a parallel case to the interesting facts published by Dr Meryon in the *Med. Chirurg. Trans.*

XIII. *On Organic Polarity.* By H. F. BAXTER, Esq. M.R.C.S.L. Communicated by C. LESTOURGEON, M.A., F.C.P.S.

[Read March 8, 1858.]

THE title that has been chosen, viz. "*Organic Polarity*," as the subject of the present communication may render it necessary to make a few preliminary observations on the object I have in view.

The subject treated of embraces that commonly included under the name of "*Animal Electricity*," or, more correctly speaking, that of "*Electro-Physiology*." The confused notions associated under the former head, and the absurdities that have been advanced in regard to Animal Magnetism and Mesmerism, together with other equally ridiculous opinions, may, in a great measure, account for the strong prejudices that are entertained towards investigations such as form the subject of the present paper, and this alone would form one strong ground for discarding the employment of that title, viz. that of Animal Electricity. But the title that has been selected, will be found, it is believed, to be the most appropriate; for it will be shewn in the sequel, that I have to treat of *polar actions*; that *organic* actions are accompanied with the manifestation of *current electricity*, and are therefore *polar* in their nature; and, consequently, it is upon this ground that it may be inferred that *organic force* is a *polar force*. Hence ORGANIC POLARITY will form the subject of the present communication.

ON THE MANIFESTATION OF CURRENT FORCE DURING THE ORGANIC PROCESS OF
SECRETION IN THE LIVING OR RECENTLY-KILLED ANIMAL.

After DAVY'S celebrated discovery, in 1806, of the *decomposition* of the alkaline salts by voltaic electricity, and when he had established the important fact that *acids* were evolved at one pole and *alkalies* at the other pole of the battery (from whence arose the phrase *polar decomposition*), WOLLASTON immediately seized upon the idea that the animal secretions were effected by the agency of a power similar to that of a voltaic circle, and in the paper* containing this remarkable conjecture, which was published in 1809, he also suggested that "the qualities of each secreted fluid may hereafter instruct us as to the species of electricity that prevails in each organ of the body;" that as the stomach and kidneys secreted an acid for example, whilst the liver secreted an alkaline compound, the two former might indicate a *positive* electric state or condition, and the latter a *negative* state or condition. PROUT† cautiously advanced a somewhat similar opinion, and says, "Admitting that the decomposition of the salt of the blood, &c is owing to the immediate agency of a modification of electricity, we have in the principal digestive organs a kind of galvanic apparatus, of which the mucous membrane of the stomach and intestinal canal, generally, may be considered as the acid or positive pole,

* *Philosophical Magazine*, Vol. XXXIII. p. 488.

† *On Stomach and Urinary Diseases*, 3rd. edit. p. xxv.

while the hepatic system may, on the same view, be considered as the alkaline or negative pole. He also quotes an experiment of MATTEUCCI as, in some degree, confirming his opinion.

DONNÉ*, upon applying one of the electrodes of a galvanometer to the stomach and the other to the liver, obtained an effect upon the needle, and the result of this experiment was subsequently confirmed by MATTEUCCI†.

The suggestion thus thrown out, that the stomach and liver formed *poles* similar to those of a galvanic pile, having apparently received some confirmation from *experimental evidence*, it now became of some importance to trace out the *circuit*, the *path* of the current; and, if possible, the *origin* of the power, so as to complete the whole evidence necessary for the proof of the truth of the suggestion.

Reasoning upon these facts, and assuming that the stomach and liver *did* actually form the two *poles* similar to those of a galvanic circle, it was reasonable to suppose that the *electric current* would pass *from* the stomach *to* the liver by the blood in the portal vein. To ascertain the truth of this supposition I now inserted the two platinum extremities of the electrodes of a galvanometer into the portal vein, and as far apart as possible, in order to obtain the supposed *diverted current*; but no effect was observed. The electrodes were then inserted one into the *portal vein*, the other into the *hepatic vein*, still no effect.

POUILLET‡ and MULLER§, it may be observed, had previously ascertained that no effect occurred when they inserted one electrode into an *artery*, and the other into a *vein*, of a living animal.

No evidence could be obtained from these experiments indicative of the *path* of the current; the galvanic circle was therefore not complete; and some of the essential conditions were evidently wanting.

Repeating the experiments of MATTEUCCI upon other animals than rabbits, the effects observed by MATTEUCCI were not always obtained; as these results will again come under consideration, they need not now detain us.

Pondering over these failures it soon became evident that more correct notions in regard to the *origin* of the power in the voltaic circle were requisite; the term *current* also, with its ordinary associations (of something flowing in *one* direction), was a source of great embarrassment, and it was thus found that a deeper insight into a knowledge of FARADAY'S|| opinions in respect both to the *origin* of the power in the voltaic circle, and to that of *current force* in particular, viz. AS AN AXIS OF POWER HAVING CONTRARY FORCES EXACTLY EQUAL IN AMOUNT IN CONTRARY DIRECTIONS, was absolutely essential. To enter upon these points, however, would far exceed the limits of this paper, and it is to the admirable memoirs of this distinguished individual that I must therefore refer for the requisite information¶.

* BECQUEREL, *Traité de l'Électricité*, Tom. 1. p. 327.

† *Ibid.* Tom. IV. p. 300.

‡ *Journal de Physiologie*, Tom. v. p. 5.

§ MULLER'S *Physiology*, translated by BALY, Vol. I. p. 148. 2nd edit.

|| *Experimental Researches in Electricity*.

¶ The title of the papers in the Transactions of the Royal Society was so worded as to imply the notion, that these investigations were undertaken for the purpose of *applying* some of the discoveries of FARADAY to Physiology. To avoid this mean-

ing a note was appended to point out in what manner the word to *apply* was intended to be understood, viz. as shewing the necessity of a thorough acquaintance with FARADAY'S views in regard to voltaic action and his definition of current force. No reason has as yet occurred to lead me to alter this opinion, but on the contrary; and whatever value may be assigned to Professor GROVE'S views, as advanced in his Essay, *On the Correlation of Physical Forces*, I am still of opinion, without wishing to detract from the merits of the latter philosopher that the views of FARADAY are by far the most philosophic.

Dismissing the notion that the stomach and liver are related to each other in the same manner as the *poles* of a galvanic circle are mutually dependent, and with a more correct knowledge of the *origin* of the power in the galvanic circle derived from FARADAY'S memoirs, the thought arose that it might be during the *formation* of the secretions where the changes were actually going on, that the evidence sought for could possibly be obtained. How far these surmises were correct will now be seen.

SECT. I. *On the Manifestation of Current Force during the formation of the Secretions in the mucous membrane of the alimentary canal, viz. the stomach and intestines.*

As the mode of employing the galvanometer and of conducting the experiments, together with the precautions necessary to be observed, have already appeared in the Philosophical Transactions of the Royal Society* for the years 1848 and 1852, it will not be necessary to enter into a minute detail of these particulars. The results also of the experiments in the present paper need only be related, as it is my intention to enter more deeply into the theoretical part of the question than could have been prudently attempted on the former occasion; for the time has now arrived, when, considering the great development that has taken place in regard to electrical science in general, we may reasonably hope to be enabled by means of scientific discussion, combined with experimental observation, to reduce the mass of unconnected facts with which the science of Animal Electricity abounds within some more general laws.

Although experiments performed upon the living animal may be considered as affording more satisfactory results, nevertheless, as the results can be obtained, when sensibility is destroyed, the following mode may be adopted in preference to the use of chloroform.

Let a few drops of strong prussic acid be dropped on the nose, insensibility is thus quickly produced; or let the animal be pithed, and upon laying open the chest or abdomen the heart will be found to beat and the circulation to continue. Under these circumstances, if the platinum electrodes of a galvanometer are placed one in contact with the mucous surface of the small or large intestine, the other in contact with the blood in a vein from the same part, a deflection of the needle will be obtained indicating a current through the instrument, the electrode in contact with the blood being *positive* to the other in contact with the mucous surface. If the same experiment be repeated with the mucous membrane of the stomach, the effects may vary. If the stomach be empty, then the electrode in contact with the blood of the vein coming from the same part will also be *positive*, but if there be any food in the stomach and should it contain much acid, then the electrode in contact with its mucous surface will most probably indicate a *positive* state. Now these are the fundamental facts and the results, which are readily obtained with proper precautions, and may be thus stated: *when the electrodes of a galvanometer are brought into contact one with the mucous surface of the intestine in a living or recently-killed animal, and the other with the venous blood from the same part, an effect occurs upon the needle indicating the secreted product and the venous blood to be in opposite electric states.*

* *Philosophical Transactions*, 1848 p. 243, 1852 p. 279.

The amount of deflection of the needle would vary according to the delicacy of the instrument employed; with an ordinary galvanometer, consisting of but few coils, the deflection was from 3° to 8° or 10° .

When the electrode, instead of being in contact with the *venous* blood, is in contact with the *arterial* blood, or the surface of the mesentery, the effects upon the needle are the same, as far as the *direction* of the current is concerned, but the amount of deflection may not be so great.

Let us now endeavour to explain these results according to known actions, such as the chemical reaction of two fluids upon each other, or to the *heterogeneity of fluids*, as it is sometimes called. If, for example, a glass cell be taken having a porous diaphragm in its middle, such as a piece of membrane, so as to divide it into two cells, and into one compartment we pour an acid solution, and into the other an alkaline solution, and then dip the platinum electrodes of a galvanometer into each of these cells, an effect upon the needle is produced indicating the electrode dipping in the acid solution to be *positive* to the other. These facts, which have been well worked out by BECQUEREL*, may be enunciated in the following proposition: *during the reaction of two fluids upon each other, that which performs the part of an acid takes positive electricity, and that of an alkali, negative electricity.*

In experiments upon animals, as just related, it was found that the electrode in contact with the *venous* blood was *positive* to the other, excepting when there was much acid in the stomach, and then the electrode in contact with the mucous surface of the stomach was *positive* to the other in contact with the blood. Now in order to explain these results, under the supposition that they arise from the chemical reactions of the fluids upon each other, it must be supposed that when the electrode in contact with the *venous* blood is *positive* to the other, that then the blood acts as an *acid*, and not only so, but *combines* with the substances or fluids in the intestines. When it is found, however, that the electrode in contact with the stomach is *positive*, then it may be supposed, and rightly so, that the results are due to the chemical reactions which occur in that organ between the acids and other fluids that are there found. But should we be justified in supposing that when the electrode in contact with the blood is *positive* to the other in the stomach, the stomach being empty or containing but little acid, that then the blood is acting as an acid? Here, as in the intestines, it would be necessary to assume that immediately after the *separation* of the secreted product (the acid) from the blood had taken place, that they then immediately recombined, and not only so, but that the blood, in direct opposition to the well-known fact of its alkaline characters, *must* be acid in order to account for the effects produced. It would, therefore, appear that no grounds exist for believing that the results obtained in the living animal can be considered as entirely dependent upon the mere reaction of the heterogeneous fluids upon each other, upon their *combination* for example; and without stopping to adduce more arguments against this supposition, let us now proceed to com-

* *Loc. cit.* Vol. II. p. 77.

pare the results with another class of phenomena, viz. with those actions which take place in a voltaic circle where *decomposition* is effected.

It will be better to confine our attention to the actions which take place in the *exciting* cell of a voltaic circle where the power *originates*, and withdraw our minds for the present entirely from the changes which take place in the *decomposing* cell of the battery where *polar decompositions* are effected: the principal object being to ascertain whether, during the *decomposition* of a compound, or during the separation of an acid from an alkali, the same effects are produced upon the galvanometer as occurs during the *combination* of an acid with an alkali.

Let us take an elementary circle, zinc, platinum, and a dilute solution of muriate of soda, and consider the two metals as forming the terminations of the electrodes of the galvanometer, one of zinc and the other of platinum, instead of having two platinum electrodes as heretofore. When the electrodes are dipped into the solution, the actions which take place are the following: the muriate of soda is decomposed by the attraction of the zinc for the chlorine or muriatic acid, whilst the soda is evolved on the surface of the platinum; now under these circumstances the platinum electrode, in contact with the soda, is *positive* to the other, and, according to common phraseology, the direction of the current is in the same direction as the *cation* (the alkaline compound, the soda) is supposed to travel. Here then is a case of *decomposition*, a separation of an acid *from* an alkali, effected by chemical agency, and the electrode in contact with the *alkali* is *positive* to the other in contact with the acid; the effect being contrary to that observed during the *combination* of an acid with an alkali, as has been just shewn. Let us now compare the results which occur in the animal with those which take place in the voltaic circle. When the electrode is brought into contact with the venous blood, it is *positive* to the other in contact with the secreting surface of the intestine; if it be now supposed that the blood is alkaline, and there is every ground for so doing, the electrode in contact with the blood is exactly similar to that in contact with the alkali in the voltaic circle; but instead of the secreted product combining with the other electrode, as the acid does in the voltaic circle, it passes away. In the animal the current may be supposed to be dependent upon the *decomposition*—if I may so term it—of the arterial blood, being as it were separated into its two elements, the secreted product and venous blood, just as the muriate of soda is decomposed and separated into its two elements, muriatic acid and soda.

At present, it may be remarked, that no opinion as to the mode in which the secretions are effected is being given; I am only endeavouring to ascertain now what does occur, and to what class of phenomena these actions, those of secretion, bear the greatest resemblance. This subject will again come under our consideration.

Before proceeding to shew that in other organs there exists the same manifestation of current force during secretion, I cannot omit noticing the opinion that WOLLASTON entertained in regard to the question now under consideration, and shall therefore quote his own words: "At the time," says WOLLASTON*, "when Mr Davy first communicated to me his

* *Loo. cit.*

important experiments on the separation and transfer of chemical agents by means of the voltaic apparatus, which was in the autumn of 1806, I was forcibly struck with the probability that animal secretions were effected by the agency of a similar electric power; since the existence of this power in some animals was fully proved by the phenomena of the Torpedo and of the *Gymnotus Electricus*; and since the universal prevalence of similar powers of lower intensity in other animals was rendered highly probable by the extreme suddenness with which the nervous influence is communicated from one point of the living system to another.

“And though the separation of chemical agents, as well as their transfer to a distance, and their transition through solids and through liquids which might be expected to oppose their progress, had not then been effected but by powerful batteries; yet it appeared highly probable that the weakest electric energies might be capable of producing the same effects, though more slowly in proportion to the weakness of the power employed.

“I accordingly at that time made an experiment for the elucidating this hypothesis, and communicated it to Mr Davy and to others of my friends. But though it was conclusive with regard to the sufficiency of very feeble powers, it did not appear deserving of publication until I could adduce some evidence of the actual employment of such means in the animal economy.

* * * *

“The experiment was conducted as follows: I took a piece of glass-tube about three-quarters of an inch in diameter, and nearly two inches long, open at both ends, and covered one of them with a piece of clean bladder. Into this little vessel I poured some water, in which I had dissolved $\frac{1}{240}$ th of its weight of salt; and after placing it upon a shilling with the bladder slightly moistened externally, I bent a wire of zinc, so that while one extremity rested on the shilling, the other might be immersed about an inch in the water. By successive examinations of the external surface of the bladder, I found that even this feeble power occasioned soda to be separated from the water, and to transude through the substance of the bladder. The presence of alkali was discernible by the application of reddened litmus-paper after two or three minutes, and was generally manifested even by the test of turmeric paper before five minutes had expired.

“The efficacy of powers,” continues WOLLASTON, “so feeble as are here called into action, tends to confirm the conjecture that similar agents may be instrumental in effecting the various animal secretions which have not yet been otherwise explained.”

There is one circumstance connected with WOLLASTON'S conjecture which must be noticed, viz. the idea that secretion depended *upon*, or is the *effect* of a power similar to that which exists in a voltaic circle; but it must be borne in mind that the *origin* of the power in the voltaic circle was not so completely understood at the time WOLLASTON published his conjecture as it is at the present day; and, although he himself was an advocate for the opinion that it depended upon chemical action, it nevertheless required the elucidation that it has subsequently received at FARADAY'S hands; the fact being that the chemical action which occurs is the *cause* of the power, or, in other words, the current is a mere manifestation of the chemical action that is taking place. I shall now pass on to the consideration of the manifestation of current force during secretion in other organs; and first, in the liver.

SECT. II. *On the Manifestation of Current Force during Biliary Secretion.*

If the platinum electrodes of the galvanometer be inserted one into the gall-bladder, and the other into the hepatic vein, or which will be found better still, in consequence of the blood flowing over the intestines, into the *vena cava ascendens* in the chest, we then obtain evidence of the manifestation of current force; the electrode in contact with the blood in the vein being *positive* to the other in contact with the bile in the gall-bladder. The amount of deflection of the needle varies from 5° to 10° .

When the electrode, instead of being inserted into the hepatic vein or into the *vena cava ascendens*, is inserted into the *vena porta*, the other remaining in the gall-bladder, the former will still indicate a *positive* state; but the effect upon the needle is not so great.

It will not be necessary to detail the results that may be obtained when other circuits are formed, between pieces of liver and clots of blood, &c. for example, shewing the effects of heterogeneity of the substances in contact with the electrodes, as these can be found in the original papers already alluded to. But the following conclusion may be deduced: *when the electrodes of a galvanometer are brought into contact, one with the bile in the gall-bladder, and the other with the blood in the hepatic vein, or vena cava ascendens, an effect occurs upon the needle, indicating the secreted product (the bile) and the blood to be in opposite electric states.*

It may be said, and with apparent justice, that if the actions which occur during secretion be similar to those that take place in the exciting cell of a voltaic battery, as was suggested in the previous Section, the electrode in contact with the *alkaline* bile ought now to indicate a *positive* state.

The force of this objection depends entirely upon the assumption that the *bile* contains a *free alkali*. The researches of chemists, and especially LIEBIG, have however shewn that with the alkaline bases which exist in the bile, are associated peculiar *organic acids*, such as the *bilic*, *choleic*, &c. As these acid compounds are easily decomposed, we should not be justified in supposing, from finding a number of indestructible basic elements which exist in the ultimate analysis of the bile, that these basic elements therefore existed as such in the composition of the bile; and although the bile may present an alkaline reaction, this alone would not necessarily indicate the existence of a *free alkali*. It would appear more reasonable to suppose that these basic elements existed in combination with the destructible *organic acids*. Similar remarks may undoubtedly be made respecting the composition of the blood, but the chemical evidence in favour of the existence of a free alkali in the blood is far stronger than that for its existence in the bile. The opinion that the fluidity of the blood may be dependent upon the alkaline salts has been long entertained by physiologists, and would appear to have received strong confirmation from the recent experiments of Dr RICHARDSON*, to which I may refer.

Having so far removed this objection, the same remarks that were made in regard to the secretion that occurs in the intestinal canal, and which I need not recapitulate, may now be

* *The Cause of the Coagulation of the Blood.* Churchill, 1858.

applied to the formation of the bile. So here in another class of secretions, additional evidence has been obtained of the manifestation of current force during secretion.

Before passing on to other secretions, I shall now notice the fallacy of supposing that the stomach and liver form poles similar to those of a galvanic battery, an idea that has been entertained by several individuals. No evidence could be obtained to shew that the stomach forms the *positive* and the liver the *negative* electrode of a circuit similar to those of a voltaic circle. It may just as well be supposed that the lungs and the stomach, or the lungs and the kidneys, or the liver and the lungs, and the kidneys and the lungs are similarly related, if we are to be guided by the mere circumstance of their relative connections in regard to the circulation of the blood through these different organs. Each organ, the stomach and liver, would appear to have, however, its own elementary circle, if I may so express it; but no evidence exists to shew that these two organs are so mutually related as to form *one* circle. There is one fact which is of some interest and deserving of notice, it is this; the blood, from which the biliary secretion is formed, has previously undergone some most important changes during its passage through the coats of the stomach and intestines, and thus an important relationship must necessarily exist between these two organs; and the question may naturally arise, Is not the blood during its passage through the coats of the stomach and intestines, and especially by the stomach, thus deprived of most of the elements of its fixed acids, such as the muriatic acid for example, and so far accounting for the small proportion of these elements that are found in the bile? It must be observed, that I am not now supposing that *all* the acids found in the stomach *must* necessarily come from the blood, for there can be no doubt that some of the acids are formed in that viscus independent of those that are secreted by that organ. But to enter upon this subject would carry us away from our main object, and I shall therefore leave it.

SECT. III. *On the Manifestation of Current Force during Urinary Secretion.*

Upon inserting one of the extremities of the electrodes of the galvanometer into the pelvis of the kidney, and the extremity of the other electrode into the renal vein of the same kidney, an effect upon the needle is produced indicating the electrode in contact with the blood to be *positive* to the other. A difficulty may sometimes arise in obtaining any effect. The amount of deflection of the needle, when obtained, varies from 3° to 5° .

Should we be justified, in this instance, in supposing that the blood is *acid* to the urine, and not only so, but *combines* with the urine, in order to account for the effects observed upon the galvanometer, when a more satisfactory explanation can be adduced by regarding the effects as being consequent upon the *separation* of the acid product from the blood, as already advanced in the previous sections with respect to the other secretions?

The amount of deviation of the needle being small, may be referred to the same causes as were observed to exist with regard to the acid secretions and fluids in the stomach. The secretion, urine, being acid, counter currents arise and are produced by the reaction of the acid of the urine upon the fluids and substances with which it comes into contact. In judging, therefore, of the effects upon the needle we must take into consideration the *acting points* in the circuit; there may be at least three acting points in a circuit, viz. at the point of secretion

and at each of the electrodes. If the *direction* of the current consequent upon secretion coincide with those that occur at the electrodes, then an increased effect upon the needle is necessarily produced; but if these currents tend to go in opposite directions, then the result upon the needle will be merely the *differential* effect. Hence we should be led to very erroneous conclusions judging merely from the effect upon the needle, either as to the *force* of the current or its *origin*.

Sufficient evidence has been obtained to warrant the following deduction, viz. *that when the electrodes of a galvanometer are brought into contact, one with the urinary secretion and the other with the venous blood from the same part, an effect upon the needle occurs indicating the blood and the urine to be in opposite electric states.*

It may just be remarked that slight effects may be observed when the electrode is in contact with the arterial blood instead of the venous blood the other being in contact with the urine. But no effects are obtained when one electrode is inserted into the vein and the other into the artery of the kidney.

Whilst upon the subject of urinary secretion I may allude to a circumstance of some interest. At the time the original experiments were performed it was frequently observed that the blood continued to indicate its *positive* condition, long after the secreting process could have been going on, which led to the belief that the blood might have the power of retaining its peculiar electrical state. Subsequent experiments have tended to confirm this opinion, but it was never supposed that the secretions could have the power of retaining their peculiar electrical condition, until lately. Reading over some of the Memoirs published at the time of the celebrated controversy between GALVANI and VOLTA, I was much gratified by accidentally finding the following interesting document. It is of some value inasmuch as it is a letter written by VASSALI EANDI, at that time one of the celebrated professors at Turin, to M. DELAMÈTHRIE, then secretary to the Royal Academy of Paris, who requested his opinion "*upon galvanism and the origin of Animal Electricity*.*" The position that these two individuals held might be adduced as giving some weight to their authority. Amongst other arguments that VASSALI EANDI brings forward in favour of the existence of Animal Electricity is the following: "J'ai prouvé ailleurs," says VASSALI EANDI, "que les urines donnent une électricité négative, et j'ai fait voir plusieurs fois aux D. GERRI, GAROTTI et aux élèves de médecine et de chirurgie, que le sang tiré des veines donne dans mon appareil électrométrique (décrit dans le Vol. V^e de l'Académie des Sciences de Turin, Dec. 19, 1790) une électricité positive."

It need scarcely be stated that the galvanometer was not then known, and that the effects observed by VASSALI EANDI were those of *attraction* and *repulsion*. Although the results obtained by VASSALI EANDI may be supposed to be due to other circumstances, such as evaporation or chemical action, than those arising from Animal Electricity, nevertheless, as recorded facts, they are of some value, inasmuch as they tend to establish similar conclusions which have been arrived at by different modes of investigation, and entirely independent of each other.

* Journal de Physique, T. XLVIII. p. 336, 1799. Germinal an. vii. Lettre de VASSALI EANDI à J. C. DELAMÈTHRIE Sur le galvanisme et sur l'origine de l'électricité animale.

SECT. IV. *On the Manifestation of Current Force during Mammary Secretion.*

In my original paper only one experiment was recorded as shewing the results that were obtained in the Mammary gland; since then several other opportunities have occurred in which similar results were observed.

If we insert the electrodes one into a lactiferous vessel and the other into a vein from the same part, the electrode in contact with the vein is *positive* to the other, 8° or 10°.

Here, in this instance, we get evidence of *the secreted product (the milk) and the venous blood being in opposite electric states.*

It will be now seen that wherever secretion occurs, whether in the stomach and intestines, in the liver, in the kidneys, or in the mammary gland, it will be found that the act itself is not only accompanied with the manifestation of *current force*, but that the *venous* blood is also, in all these instances, in the same state, in a *positive* electric state. The next question that would naturally arise is the following:—what is the state of the *arterial* blood? Although it has been found that the arterial blood indicates a *positive* state when formed into a circuit with the secreted product, the other necessary element, viz. its *electro-negative element*, the *cation*, for example, has not yet been obtained. Reasoning from analogy, it is in the lungs that a satisfactory explanation on this point must be sought for.

Physiologists may not perhaps be disposed to admit that the function of the lungs corresponds to that of a secretory organ; or that the process by which carbonic acid is eliminated from the blood corresponds to that by which the acid is eliminated from the stomach; fortunately a decision on this point will not be necessary, and therefore need not detain us. One circumstance, however, is well known, viz. that *carbon*, in some form or other, is eliminated from the blood during its passage through the lungs; and it may so happen that during the elimination of this carbon, its *separation* from the venous blood whilst traversing the lungs, that current electricity becomes manifested.

SECT. V. *On the Manifestation of Current Force during Respiration.*

When one electrode is brought into contact with the mucous membrane of the bronchial tubes, and the other inserted into the left ventricle of the heart, the latter electrode is *positive* to the former, from 2° to 5°. When the electrode, instead of being inserted into the left ventricle was inserted into the right ventricle, it still indicated a *positive* state.—Here then are indications of the arterial blood being *positive* to the mucous surface of the lungs; how far this state may be due to the *separation* of the *carbon* from the *venous* blood which traversed that organ may be a subject of dispute; the fact, however, is of some importance as indicating the electric condition of the *arterial* blood.

In looking back upon the results that have now been obtained, some surprise may be felt at the circumstance that all these experiments tend to indicate that, during life, the blood, whether *venous* or *arterial*, is in a *positive* electrical state or condition, and that this state or

condition is partly produced and maintained by the various secretions that take place in the animal body. How far the fluidity of the blood, and the vitality of the blood, as it is called, are dependent upon this electric state or condition, are questions which must necessarily arise in our minds. The particles of the blood, also, must under these circumstances exist in a state of self-repulsion; and may not this fact, it may be asked, tend to explain some of the phenomena connected with the circulation of the blood in parts not dependent upon the *vis à tergo* action of the heart, and also those connected with the coagulation of the blood when taken from the living animal? These are questions that will arise; but I must not wander too far from our present object; and therefore conclude this Section by stating that a clue has now been obtained to the non-appearance of any effect upon the galvanometer when the two electrodes are inserted into an artery and a vein, a fact previously established by the experiments of POUILLET and MULLER*. As the blood in the two vessels is in the same electric state, no effect could occur upon the needle; thus proving the fact, well established by FARADAY, that in order to obtain CURRENT FORCE the *circuit form* must be given to the arrangement, *i.e.* that *the electrodes must be brought into contact, or by means of some conducting mass, with the ANION and CATION originating the power*†.

Before entering upon the concluding remarks there are one or two points which must be noticed. It may be supposed, 1st, that the effects that have been obtained may arise from *thermo-electric actions*, since BECQUEREL‡ and BRESCHET have ascertained the existence of a difference in temperature between the *arterial* and *venous* blood by means of a galvanometer; 2ndly, that they may also arise from the actions that take place upon the surface of the platinum electrodes. There can be no doubt that a part of the effects may be referred to both of these circumstances, and they must therefore be taken into consideration when judging of the final result upon the needle. As these objections have however been already noticed in one of the original papers§, I cannot do better than refer to the experiments and arguments there brought forward for their refutation.

Concluding Remarks.

The results recorded in the present and previous papers tend to establish the following conclusion, *viz.* that *the act of secretion in the living animal is accompanied with the manifestation of CURRENT FORCE*; and the phenomena with which this act of secretion appears to be the most intimately related are those that occur in the voltaic circle, as I have endeavoured to point out in the present paper. A difficulty may arise to some minds in perceiving this relation, from the circumstance that in the ordinary voltaic circle metals are employed. If we bear in mind that the metals, although one of them is usually acted upon, serve principally as *conductors*, and that they are not *essential* for the development of the power, this difficulty will be easily removed. Now as the manifestation of *current force* during the actions which occur in the voltaic circle are considered as evidence of *polar* action, there can

* *Loc. cit.*

‡ *Loc. cit.* Tom. VII. p. 20.

† *Experimental Researches*, Vol. II. p. 51.

§ *Phil. Trans.* 1852, p. 279.

be no reason why it should not be so considered in regard to organic action, viz. during secretion; but before we arrive at this conclusion let us compare the phenomena of secretion with another class of facts, viz. with those of *osmose*.

PROFESSOR GRAHAM has communicated a very valuable paper to the Royal Society, entitled *On Osmotic Force*, which has lately appeared in their *Transactions**. In this paper Professor GRAHAM has shewn that *osmose* is dependent upon *chemical action*, and not as it has been generally supposed, upon *capillary attraction*. Time will not allow me to enter upon the facts brought forward in support of this opinion, and I must therefore refer to the paper itself, which cannot be too strongly recommended.

The conditions under which an *osmotic* experiment is conducted, viz. the necessity of having two fluids, one on each side of the septum, render it extremely difficult to ascertain by means of the galvanometer the exact mode of action which arises during *osmose*, so as to compare it with that which takes place in the animal body during *secretion*, in consequence of the reaction of the two fluids upon each other producing their own peculiar effects on the galvanometer; and the changes upon which *osmose* depends take place, according to Professor GRAHAM, *within* the substance of the porous diaphragm, where we cannot apply the electrodes of the galvanometer.

The fact of *osmose* depending upon chemical action shews however that the act itself must not be considered as a mere transudation, a mere physical separation, but that it depends upon other important conditions; and if upon chemical action they are consequently polar in their nature. If this conclusion be arrived at in regard to osmotic phenomena we may with equal propriety consider the phenomena connected with secretion to be at least something more than a mere physical transudation; and as reasons exist for shewing that osmotic phenomena are polar in their nature, why may we not consider the action connected with secretion, and where we can obtain such direct evidence of polar action, as manifested by the galvanometer, to be polar in their nature also?

Respecting the chemical character of *osmose*, and its bearings upon physiology, Professor GRAHAM adds:—"It may appear to some that the chemical character which has been assigned to *osmose* takes away from the physiological interest of the subject in so far as the decomposition of the membrane may appear to be incompatible with vital conditions, and osmotic movement confined therefore to dead matter. But such apprehensions are, it is believed, groundless, or at all events premature. All parts of living structures are allowed to be in a state of incessant change—of decomposition and renewal. The decomposition occurring in a living membrane, while effecting osmotic propulsion may possibly be of a reparable kind. In other respects chemical *osmose* appears to be an agency particularly well adapted to take part in the animal economy."

The subject of the present communication has been that of ORGANIC POLARITY, and to this it has been my endeavour to confine our attention, and to shew that some of the organic actions which occur in the animal body, viz. *secretions*, are evidently accompanied with the manifestation of *current force*; a fact which may not be disputed. An endeavour has been made

* *Phil. Trans.* 1854.

also to point out with what class of phenomena they appear to be the most nearly allied, viz. those which occur in voltaic *decomposition* (a conjecture already advanced by WOLLASTON); and as these are considered as *polar* in their nature we are justified in logically inferring that those which occur in the animal body are likewise *polar* in their nature; and as chemical force is considered a polar force, so may organic force be viewed in the same light as a polar force also. But the conditions under which polar phenomena are manifested, in the organic, at once stamp them as of a higher order than those which are observed in the inorganic kingdom of nature.

Cambridge, Feb. 1858.

XIV. *A proof of the Existence of a Root in every Algebraic Equation: with an examination and extension of Cauchy's Theorem on Imaginary Roots, and Remarks on the Proofs of the existence of Roots given by Argand and by Mourey. By AUGUSTUS DE MORGAN, F.R.A.S., of Trinity College, Professor of Mathematics in University College, London.*

[Read Dec. 7, 1857.]

To those teachers who value the logic of mathematics it has always been a subject of regret that the fundamental proposition of the theory of equations—every algebraical equation has as many roots as dimensions, and no more—is either to be taken on trust, or deferred to a late period of the course. Every such proceeding is, in mathematics, a confession of incompetency, either in the state of the subject or in the teacher. This confession I have until now been obliged to make by deferring the proof of the theorem until it can be deduced from Cauchy's theorem on the limits of imaginary roots, a theorem which incidentally brings out the *existence* of the roots. Having been recently led to examine the first* of Sturm's demonstrations of this theorem, in the first volume of Liouville's Journal, it struck me, from the very *fundamental* character of this proof, that there must be some equally fundamental demonstration of the existence of the roots, which would be the natural prefix to Sturm's demonstration. Attentive examination proved my conjecture to be correct; and at the same time I found an addition to Cauchy's theorem, which makes it include roots derived from the *circuit* itself, and also roots of the reciprocal of the function in hand. This I shall incorporate with Sturm's proof in the present paper: joining with it the consideration of Argand's and Mourey's proofs, which have points worthy of particular attention.

The proof which I prefix to Sturm's demonstration depends upon a preliminary theorem, which is one of combination and position. It takes no account of the meaning of 0, ∞ , +, -, but only postulates that + and - shall be separated either by 0 or by ∞ . All changes consistent with this condition are to be held allowable. Then + 0 + may become + +: but + 0 - must not become + -. Either 0 or ∞ may *open*; that is, 0 may become 0 - 0, or 0 + 0, or 0 [+ 0 - ∞ + 0 -] 0 &c. Again + may become + 0 + or + ∞ +; and so on. And 0 and ∞ may come together, and either cross each other or recede from each other without crossing; having, after crossing or recession, either the same sign between them as before, or a different sign.

THEOREM. In any number of signs, each of which is + or -, interspersed with the signs 0 and ∞ , in any manner which satisfies the condition that either 0 or ∞ always comes between + and - and between - and +, let k be the number of occurrences of + 0 -, and l the number of occurrences of - 0 +. Then it is impossible that $k - l$ should undergo

* I mean the first by Sturm alone: the first in the memoir cited is by Sturm and Liouville jointly.

any alteration, unless by 0 and ∞ coming together, whether with change of place or simple recession. It is supposed that the series both begins and ends with a sign + or -, which remains unaltered; not with 0 or ∞ .

Except *appulse* of 0 and ∞ , the only other changes are appearance or disappearance of 0 between like signs, appearance or disappearance of ∞ between like signs, opening of 0 or ∞ into 00 or $\infty\infty$ with signs between them. A simple induction will shew that, in every case which involves no *appulse* of 0 and ∞ , either k and l remain unaltered, or receive the same increment.

Thus when +0+ changes into ++, both are unaltered: as also in -0+ changed into -0-0+, or -0- changed into -0[-0-]0-. But in +0+ changed into +[0-0]+, both k and l increase by a unit: in +0- changed into +0[-0+0-]0-, both receive a unit of increase. But when -0- is changed into -0[- ∞ +]0-, in which case k augments by a unit, while l is unchanged, the change, if continuous, commenced by an appulse of 0 and ∞ , as in 0 ∞ 0. Again, when -0+ ∞ + changes through -0 ∞ + to - ∞ +0+, in which case l loses a unit, there is an appulse of 0 and ∞ . This theorem brings the fundamental theorem on the roots of equations to rest on what will readily be acknowledged to be its proper foundation, the necessity of 0 or ∞ in the transition from positive to negative.

Now suppose a line of any sort drawn in a plane, and at each point of it, (x, y) , let the sign of a given function of x and y be recorded; with the character of each change, +0-, -0+, + ∞ -, - ∞ +, as the case may be. Every contour, and every portion of a contour, will thus present what we may call a *chain of signs*, such as +0-0+ ∞ -0+..., with reference to any function of x and y which may be chosen. If the contour, or part of a contour, change continuously, so as to pass gradually from one form and position to another, changes may occur in the chain; and it is obvious that the change may be so conducted, that not more than one of the signs 0 and ∞ shall be affected at any one moment. If the function examined be $\frac{P}{Q}$, where P and Q never become infinite for any finite values of x and y , then 0 can only appear when $P = 0$, and ∞ can only appear when $Q = 0$, and an appulse of 0 and ∞ can only take place where $\frac{P}{Q}$ takes the form $\frac{0}{0}$. Next, suppose ϕz to be a function which never becomes infinite for any finite value of z , and let $\phi(x+y\sqrt{-1}) = P + Q\sqrt{-1}$. We see then that if $k - l$ be found to have, on one contour, a value different from what it has on any other contour, a gradual transition from one contour to the other cannot be made without the varying contour passing through points at which $P = 0$, $Q = 0$, or $f(z) = 0$. Such point or points then must exist; or we have the following

THEOREM. If $f(x+y\sqrt{-1}) = P + Q\sqrt{-1}$, and if neither P nor Q can be infinite for any finite values of x and y ; if also two contours can be found for which $k - l$ has different values; then such difference of value is proof of the existence of a root or roots which satisfy $\phi z = 0$.

It is supposed that the choice begins and ends with fixed signs. This always takes place when we go round the whole of a closed circuit, from one sign to the same again. But we have also seen that, so long as the initial and terminal signs remain the same, it is impossible

for a contour which is only part of a circuit to be changed into part of another contour having a different value of $k - l$, without passing over one or more of what I call *radical points*.

If ϕz be a rational and integral function, the possibility of assigning closed circuits which have different values of $k - l$ is easily shewn. When an angle gains a revolution by continued increase, the cotangent of that angle passes through two changes of the form $+ 0 -$, and two of the form $- \infty +$. When the gain of a revolution is a balance of increase and diminution, every case of $- 0 +$ which occurs during diminution is accompanied by a case of $+ 0 -$ which occurs during restoration, over and above the two cases of $+ 0 -$ which belong to the balance.

Consequently, whenever $\frac{P}{Q}$ is the cotangent of an angle which gains a revolution during the progress of (x, y) round a closed circuit, $k - l$ acquires two units in that revolution, and two units in every such revolution. If the angle change only by increase, we have $k = 2, l = 0$, for each revolution.

Representing $a(\cos a + \sin a \sqrt{-1})$ by a_α , &c., and $x + y \sqrt{-1}$ or $r(\cos \theta + \sin \theta \sqrt{-1})$ by r_θ , let $\phi(x + y \sqrt{-1})$ be $a_\alpha r_\theta^n + b_\beta r_\theta^{n-1} + \dots + m_\mu$: in which, to avoid a visibly existing root, we suppose that m has value. We see then that

$$\frac{P}{Q} = \frac{ar^n \cos(n\theta + \alpha) + br^{n-1} \cos[(n-1)\theta + \beta] + \dots + m \cos \mu}{ar^n \sin(n\theta + \alpha) + br^{n-1} \sin[(n-1)\theta + \beta] + \dots + m \sin \mu}.$$

If a closed circuit be taken in which all the values of r are infinitely small, we see that $P:Q$ is either constant, or, where $\cos \mu$ or $\sin \mu$ vanishes, varies directly or inversely as the cosine or sine of a multiple of θ altered by a constant. In these cases each revolution gives k and l both = 0, or both the same integer: that is, $k - l = 0$. But if throughout the closed circuit r be infinitely great, the value of $P:Q$ is always $\cot(n\theta + \alpha)$ and $k - l$ acquires two units for each accession of 2π which $n\theta + \alpha$ receives, while θ changes from 0 to 2π : that is, $k - l = 2n$. Hence the proposition that ϕz always has a root or roots is proved. We then, in the common way, establish the existence of the root-factor, and the number of the roots.

Previously to proceeding further, I discuss a point which is of great importance, and bears on many of the proofs of the preceding proposition. Dr Peacock (*Report on Analysis*, p. 305) objects to making *interpretation* the foundation of important symbolical truths, which, he maintains, should be considered as necessary results of the first principles of algebra, and ought to admit of demonstration by the aid of those principles alone.

Interpretation is, or at least begins with, the application of meaning of fundamental symbols to the deduction of meaning for compound symbols. It may be applied to throw light on the steps of a demonstration, and in this way it must be applied: without it algebra is a valley of dry bones. It may also be applied to furnish steps of demonstration; and this sort of application must be sternly resisted: the result is not algebra. But on this point the following distinction suggests itself.

Every proposition is true of which the truth can be shewn. Demonstration of the possibility of demonstration is itself demonstration; demonstration of the possibility of demonstrating the possibility of demonstration is also demonstration: and so on. Mathematical teaching has used this principle rather too extensively. A proposition proved to be true of commensurables is allowed to be assumed as to incommensurables, on the feeling that its truth as to

commensurables is proof that a demonstration *can be found* as to incommensurables. If a step suggested by interpretation, and seen to be a true step by perception of the necessary consequences of interpretation, be allowed to stand part of the proof, without anything further, this question then arises, Can the step of interpretation be supplied by an algebraical substitute? If yes, then the substitution ought in strictness to be made, and it must be made on demand: if no, then the proof cannot be called either actually or potentially algebraical.

The proof which I have given above is not, in the very strictest sense, algebraical. All its *geometrical* interpretations might very easily be replaced by algebraical ones; not so its *arithmetical* interpretations. It hinges on the use of *greater* and *less*, when we come to apply the preliminary theorem to ϕz . Let all the letters denote *operations*, how are we to prove that $X^5 + AX + B$ performed on ϕx is the result of five successive operations of the form $X - C$? I do not believe that any proof* exists except that which is derived from our knowledge that transformations deduced from quantitative interpretations, upon no assumptions as to the specific magnitude of the quantities, are symbolically valid.

I now proceed to supply the algebraical substitute for a geometrical step which occurs in Sturm's proof of Cauchy's theorem, and in Mourey's proof of the fundamental theorem. When a closed circuit is described, say in the positive direction of revolution (that is, in the direction which, on the whole balance of positive† and negative revolution, makes the radius drawn from *some one* point inside it *gain* four right angles), then the radius drawn from *any one* point whatsoever *inside* the circuit gains four right angles; the radius from any point *outside* neither gains nor loses, performing as much positive revolution as negative; the radius from any point *on* the circuit gains two right angles during continuous revolution, and a second pair of right angles *per saltum*, in passing through its vanishing position. This is as evident as can be when the figure is looked at.

Let one point, within the contour, be taken as the origin: let the radius from this point to (x, y) be r , and its angle with the axis of x be θ . Let there be another point within, on, or without, the circuit, at a radius m and angle μ with respect to the origin. Let the radius from the point just named to (x, y) be s , and its angle σ . Remember that r, m, s , are positive. We have then $r \cos \theta = m \cos \mu + s \cos \sigma$, $r \sin \theta = m \sin \mu + s \sin \sigma$, $\tan \sigma = \frac{r \sin \theta - m \sin \mu}{r \cos \theta - m \cos \mu}$.

Now it is the *algebraical* property of this last formula, independent of all geometrical interpretation to those who *algebraize* the sine and cosine, that while θ changes from 0 to 2π , σ gains 2π , or gains π , or gains nothing; *and never loses*. Let $\sigma = \mu + \psi$: we then deduce

$$\tan \psi = \frac{r \sin (\theta - \mu)}{r \cos (\theta - \mu) - m}.$$

* The celebrated proof of Laplace, or rather his improvement of the proof given by Foncenex (*Leçons de l'Ecole Normale*, vol. ii. p. 315), has often been cited as a proof that every equation has roots. The first words of Laplace are "Soient a, b, c , &c. les diverses racines de cette équation..." and the proposition proved is that these roots are of the form $m + n\sqrt{-1}$. Dr Peacock's form of this proof (*Report on Analysis*, p. 298), begins by shewing that the possibility of roots stands or falls with the possibility of symbols, all whose symmetrical products

are given symbols. But the assumption of this possibility is a difficulty of the same kind.

† The circuit must not be *autotomic*. Subject to this condition it makes any undulations. With respect to an internal point, any point which describes the circuit revolves in one way, positively or negatively, while it is *hidden* from the internal point by an even number of intervening parts of the circuit, and in the other way, negatively or positively, while it is hidden by an odd number of intervening parts.

We see that $\tan \psi$ makes the change $+0-$ or $-0+$ only when $\sin(\theta - \mu) = 0$, $\cos(\theta - \mu) = \pm 1$. If $r < m$ at $\theta = \mu$ (which answers to taking the second point outside the contour) $\tan \psi$ in both cases goes through the changes of $\sin(\theta - \mu)$ inverted: that is, through $+0-$ and $-0+$, at $\theta = \mu$, $\theta = \mu + \pi$. That is, $\tan \psi$ returns to its first value, at $\theta = 2\pi$, by a balance of positive and negative revolutions: ψ could not give a revolution without two $-0+$ changes in the tangent. If $r > m$ when $\theta = \mu$ (which answers to taking the second point inside the circuit), then, at $\theta = \mu$, $\tan \psi$ goes through $-0+$, and at $\theta = \mu + \pi$, also through $-0+$: that is, $\tan \psi$ recovers its first value at $\theta = 2\pi$ by gaining a whole revolution. But if $r = m$ when $\theta = \mu$ (which answers to taking a point on the contour) then $\tan \psi$ passes through $\frac{0}{0}$ without change of sign, and $s \sin \sigma$, or $m(\sin \theta - \sin \mu)$ changes sign without s changing sign: that is, σ receives, per saltum, an accession or diminution of π .

At $\theta = \mu + \pi$, $\tan \psi$ undergoes the change $-0+$ which, not being compensated until $\theta = \mu + 2\pi$, shews half a revolution added to ψ by the time ψ gains its original value.

Appealing to the above as algebraical proof of the requisite property of the circuit, and using the geometrical phrases only as combined abbreviation and elucidation, I shall now proceed to Cauchy's theorem, which with its extension is as follows.

Let ϕx be any rational function whatsoever, and $\phi(x + y\sqrt{-1})$ being $P + Q\sqrt{-1}$, let $\frac{P}{Q}$ be recorded while the point (x, y) describes any closed circuit in the positive (or rather *positive-balance*) direction of revolution. Let k be the number of $+0-$ changes, l the number of $-0+$ changes. Let m and m' be the numbers of points *within* and *upon* the circuit, at which $\phi(x + y\sqrt{-1}) = 0$. Let p and p' be the numbers of points *within* and *upon** the circuit at which $\phi(x + y\sqrt{-1}) = \infty$. Then

$$k - l = 2m + m' - (2p + p').$$

Cauchy included only the case in which, by hypothesis, $m' = 0, p = 0, p' = 0$.

Let the function be a rational algebraical fraction, in which the roots of the numerator come under $a_n(\cos \alpha_n + \sin \alpha_n\sqrt{-1})$ and of the denominator under $b_n(\cos \beta_n + \sin \beta_n\sqrt{-1})$.

Let the function be $\phi(x + y\sqrt{-1})$, $x + y\sqrt{-1}$ being $r \cos \theta + r \sin \theta\sqrt{-1}$, and let

$$r \cos \theta - a_n \cos \alpha_n + (r \sin \theta - a_n \sin \alpha_n) \cdot \sqrt{-1} = s_n (\cos \sigma_n + \sin \sigma_n \sqrt{-1}),$$

$$r \cos \theta - b_n \cos \beta_n + (r \sin \theta - b_n \sin \beta_n) \cdot \sqrt{-1} = t_n (\cos \tau_n + \sin \tau_n \sqrt{-1}).$$

The function $\phi(x + y\sqrt{-1})$ is therefore a constant multiplied by the following fraction

$$\frac{s_1 s_2 \dots (\cos \sigma_1 + \sin \sigma_1 \sqrt{-1}) (\cos \sigma_2 + \sin \sigma_2 \sqrt{-1}) \dots}{t_1 t_2 \dots (\cos \tau_1 + \sin \tau_1 \sqrt{-1}) (\cos \tau_2 + \sin \tau_2 \sqrt{-1}) \dots}$$

* Sturm says, positively, that there can be no theorem when a root is on the contour, for that different contours containing the same numbers of radical points, may in that case give different values of $k - l$. But this was said after the first proof, which he and Liouville gave together, and before the second proof, which I am now translating into my own language, as applied to the extended proposition. Had he reconsidered his assertion while employed on the second proof, he could not have

missed the introduction of m' . Any one who will take up the point as a question of continuity by the aid of the curves $P=0, Q=0$, will easily detect the loss of a change of the form $+0-$, or a gain of $-0+$, when the circuit passes over an intersection of the curves $P=0, Q=0$. In this he will need the following theorem, which is easily proved:—when the circuit passes through an intersection of $P=0, Q=0$, either both P and Q change sign, or neither.

$$\text{Whence } \frac{P}{Q} = \cot(\sigma_1 + \sigma_2 + \dots - \tau_1 - \tau_2 - \dots)$$

Now it has been proved, algebraically, that for every one of the radical points, whether of numerator or denominator, *within* the circuit, σ_n or τ_n gains 2π ; *on* the circuit, π continuously, and π *per saltum* without effect upon sign; without the circuit, 0. The theorem is now obvious. As to the excess of k over l , it matters nothing whether we make θ pass from 0 to 2π , in any of the angles $\sigma_1, \sigma_2, \dots, \tau_1, \tau_2, \dots$ consecutively, or in all at once. In the first case, $\sigma_1 + \sigma_2 + \dots$ gives to the cotangent $2m + m'$ changes of the form $+0 -$ if the circuit be convex, and none of the form $-0 +$; while if the circuit be not convex, the changes of the first kind exceed those of the second by $2m + m'$. At the same time, $-\tau_1 - \tau_2 - \dots$ gives an excess of $-0 +$ changes over $+0 -$ changes of $2p + p'$.

The theorem is universally true for all functions in which a root factor of the first dimension exists for every root. The proof most commonly given (the joint proof of Sturm and Liouville) depends upon the consideration that where two closed circuits having no common area have some portion of boundary circuit in common, the sum of the values of $k - l$ for the two separately is the value of $k - l$ for the single circuit made by neglecting the common boundary. And this because the common boundary, being described in different directions in the two circuits, contributes towards k in one circuit what it contributes towards l in the other; and *vice versa*. Hence any circuit* may be divided into an infinite number of infinitely small circuits; and the theorem, being proved true for an infinitely small circuit, is true for the circuit made of the outer line of all the subdivisions. There is no occasion, after what precedes, to shew that if

$$\phi(x + y\sqrt{-1}) = (x + y\sqrt{-1} - a \cos \alpha - a \sin \alpha \sqrt{-1})^{\pm m} \psi(x + y\sqrt{-1}),$$

where $\psi(a \cos \alpha + a \sin \alpha \sqrt{-1})$, does not vanish, an infinitely small contour described about the point $(a \cos \alpha, a \sin \alpha)$ gives $k - l = \pm 2m$ or $\pm m$, according as the point is within or upon the contour.

The theorem fails when the root factor enters with a fractional exponent: unless indeed we propose an extension so vague as a theorem constructed on the trial of all integer powers of ϕz .

Let the function be one in which every root-factor is of the first dimension, subject to the usual definition of equal roots; and let it never become infinite for finite values of x and y . Then the curves $P = 0$, $Q = 0$, the intersections of which determine the root-points, are such that two branches, one of each curve, cannot inclose a space. At each root-point, the branches which there intersect, must make known the existence of that root on every circuit which contains the point, however large. The four places in which a branch of $P = 0$ and one of $Q = 0$ meet any circuit, supposed convex, give $+0 -$, $-\infty +$, $+0 -$, $-\infty +$, which are just sufficient to indicate one root. No second root-point can then be determined by these branches. This is not, however, a definition of all curves which cannot inclose space; for $P = 0$ and

* Those who remember the treatment of the electric circuit | ber that this is also the way in which an infinitely small cur-
by Ampère (I think, but it is long since I read it) will remem- | rent is integrated into any current whatsoever.

$Q = 0$ always intersect orthogonally; and do not, therefore, contain so much as all pairs of straight lines. There are other conditions of intersection and of sequence on which I do not here enter.

I now proceed to give the proof of the fundamental proposition which Argand gave (1815) in the fifth volume of Gergonne's *Annales*, p. 204. I repeat this proof here, first to separate it entirely from the interpretation by double algebra which it was Argand's principal object to illustrate, and which he did illustrate with great effect: secondly, to remark that, in a much more simple form, it is the proof which Cauchy afterwards hit upon, and published, first (1820) in the *Journ. de l'Ecole Polytech.* vol. xi. p. 411, and afterwards (1821) in the *Cours d'Analyse*, p. 331, a work, to which, as a student, I was much indebted. Argand's proof rests upon the easily proved proposition, that r_θ signifying $r \cos \theta + r \sin \theta \sqrt{-1}$, &c. and p, q , &c. being ascending positive exponents, the length or modulus of $a_\alpha r_\theta^\alpha + b_\beta r_\theta^\beta + c_\gamma r_\theta^\gamma + \dots$ may, by taking r small enough, be made as nearly equal as we please to that of $a_\alpha r_\theta^\alpha$, and the angle of the first as nearly equal as we please to that of the second. This, under the interpretations of the complete, or double algebra, is instantly perceptible, and the pure algebraical proof is very easy. This being premised, let us take $a_\alpha r_\theta^\alpha + b_\beta r_\theta^{\beta-1} + \dots + k_\kappa r_\theta + l_\lambda$, which call $U(\cos Y + \sin Y \sqrt{-1})$. If it be impossible to take r_θ so that $U = 0$, it follows that values of r and θ exist which give for U a value which cannot be lessened. Let m_μ be this value of r_θ , and for r_θ write $m_\mu + h_\eta$, which, D_Δ being the value of least modulus just mentioned, changes the expression into the form

$$D_\Delta + A_a h_\eta^p + B_b h_\eta^q + \dots$$

where, p, q , &c. are ascending positive exponents. Take h so small that the effect produced on $A_a \cdot h_\eta^p$ by the succeeding terms shall be useless in the following considerations. The first two terms give

$$D \cos \Delta + D \sin \Delta \sqrt{-1} + \{ Ah^p \cos (p\eta + a) + Ah^p \sin (p\eta + a) \cdot \sqrt{-1} \}.$$

Here η is at our pleasure. Assume $p\eta + a = \Delta + \pi$, the preceding then becomes

$$(D - Ah) (\cos \Delta + \sin \Delta \cdot \sqrt{-1}),$$

which, A and h being positive, as they may be, the angles furnishing negative signs when wanted, has a modulus less than that which cannot be lessened; which is a contradiction. No less acute a person than Servois did not see that this contradiction deduced from the assumption of one of two necessary alternatives, is final in favour of the other. He pleaded to the contradiction that it was not shewn to be large enough; and in so doing he has added one to the many cases which prove that a severer study of pure logic would be useful to the mathematicians. He contends that Argand was bound not merely to shew a *less than the least*, but to shew that this less than the least might be made as near as we please to zero. Argand's argument was precisely that of Euclid in the proof that pyramids of equal bases and altitudes have equal solidities; the difference is nothing because, *whatever else* may be named for the difference, it can be shewn to be too large. The minimum modulus must be nothing, because, whatever else may be taken for the least modulus, it can be shewn to be too large. Servois forgot that the opponent who undertook to convince him had allowed him to begin by

taking D as small as he should please, before he began to shew that it might have been taken yet smaller.

Argand's proof is quite fundamental, and is the most direct of all. Its so called indirect character is nothing but a case of the habit of the mathematicians not to admit the identity of contrapositive forms without proof. To a logician the following forms, 'Every quantity which is not 0 is not the minimum,' and 'the minimum is 0' are identical, the existence of the terms being known. If Cauchy's theorem were not to form part of a course, I should recommend Argand's proof; and I should, in any case, insert Argand's as supplementary to the one I have before given.

Argand and Mourey were both in full possession of double algebra up to the interpretation of *real* exponents inclusive. The manner in which, at what is thereby proved to be the due time, persons of all kinds, unconnected with each other and unknowing of each other's existence, will take up a subject of speculation, of observation, or of experiment, is becoming better and better known from day to day. Remembering that Mr Airy, more than five-and-twenty years ago, casually told me that he had occupied himself with the interpretation of $\sqrt{-1}$ at a very early period of his studies, I lately begged of him to let me see any notes which he might have made on the subject. The reply was the transmission of a manuscript, drawn up in the form of a paper for a scientific society, dated January 21, 1820, and therefore written in the first three months of the author's residence at Cambridge. It contains, with many examples, a full interpretation of the roots of $+1$ and of -1 ; and commands the full meaning of $+$ and of $-$, and of \times so far as relates to the formation of powers. The idea on which it starts is, like that of Argand, the assumption of proportion, in the case of lines, as involving equal differences of direction, as well as equal quotients of length. Of Argand Mr Airy knew nothing; of Buée as much as this, that he had been told a Frenchman had treated the subject in the *Philosophical Transactions*.

Mourey's* proof is as follows. It is much defaced in the original by peculiarities of notation: the author had the idea that he was in possession of a *new algebra*, not the old algebra under extension of interpretation.

First, it is shewn that the equation which is expressed in my foregoing notation by

$$r_{\theta}(r_{\theta} - a_{\alpha})(r_{\theta} - b_{\beta}) \dots = m_{\mu},$$

must have a root or roots.

The first side of the equation being altered as before, we have

$$rs_1s_2 \dots \{ \cos(\theta + \sigma_1 + \sigma_2 + \dots) + \sin(\theta + \sigma_1 + \sigma_2 + \dots) \sqrt{-1} \} = m(\cos \mu + \sin \mu \sqrt{-1}).$$

As before shewn we know that while θ changes from 0 to 2π , no one of the angles $\sigma_1, \sigma_2, \dots$ loses value on the whole, while such as gain must increase by π , or by 2π , consequently $\theta + \sigma_1 + \sigma_2 + \dots$ increases by 2π + (0 or some multiple of π). At some value or values of θ , then, we have $\cos(\theta + \sigma_1 + \dots) = \cos \mu$, $\sin(\theta + \sigma_1 + \dots) = \sin \mu$. Next, this value of θ being supposed to be determined, we have

$$rs_1s_2 \dots = r \sqrt{\{r^2 - 2ar \cos(\theta - \alpha) + a^2\}} \cdot \sqrt{\{r^2 - 2br \cos(\theta - \beta) + b^2\}} \dots$$

* *La vraie Théorie des quantités négatives et des quantités prétendues imaginaires. Dédié aux amis de l'évidence.* Par C. V. Mourey. Paris, Bachelier, 1828; pp. xii: + 144, 3 plates.

which vanishes when $r = 0$, and finally increases without limit with r . At some value or values, then, of r , we have $rs_1s_2 \dots = m$. Consequently, the given equation has one or more roots: that is, every equation of the form $x(x-a)(x-b) \dots = m$ has one or more roots.

Next, it follows that if every expression of the $(n-1)$ th degree has $n-1$ roots, every expression of the n th degree has n roots. First,

$$ax^n + bx^{n-1} + \dots + kx + l \text{ is } ax(x^{n-1} + \dots + k) + l,$$

which, since every expression of the $(n-1)$ th degree has $n-1$ roots, is $ax(x-a)(x-\beta) \dots + l$, and this, by the preliminary theorem, has one root. Consequently, $ax^n + bx^{n-1} + \dots$ is of the form $(x-a)(ax^{n-1} + bx^{n-2} + \dots)$ which again is $(x-a) \times$ the product of $n-1$ such other factors. Whence $ax^n + \dots$ has n roots, if every such expression of one degree lower have $n-1$ roots. All the rest follows from the expression of the first degree having one root.

A. DE MORGAN.

UNIVERSITY COLLEGE, LONDON,
December 18*, 1857.

Postscript.

I SUBJOIN some brief remarks on a couple of elementary points.

1. I find that the following theorem is new to several mathematicians to whom I have proposed it. It may be most briefly expressed as follows: Any two *divergent* series whatsoever, of the same character as to signs of the terms, are to one another in the ratio of their last terms. That is, if $a_0 + a_1 + a_2 + \dots + a_n$ and $b_0 + b_1 + b_2 + \dots + b_n$ give results which become infinite with n , the limit of the ratio is that of a_n to b_n ; and this, whatever the signs of $a_0, b_0, \&c.$ may be, provided only that a_n and b_n always have like signs. Thus $1 + 2 + 3 \dots$ and $1 + 3 + 5 + \dots$ are infinites in the ratio of 1 to 2; and so are $1 - 2 + 3 - \dots$ and $1 - 3 + 5 - \dots$; and so are $1 + 2 - 3 + 4 + 5 - 6 + \dots$ and $1 + 3 - 5 + 7 + 9 - 11 + \dots$. I speak only of arithmetical summation, without reference to the value of the evolving function, when finite. Apply this to $\Sigma \cdot n^k$ and $\Sigma \{(n+1)^{k+1} - n^{k+1}\}$, and we have ($k > -1$), the proposition out of which Cavalieri and his successors produced a limited integral calculus.

Apply it to Σn^{-1} and $\Sigma \{\log(n+1) - \log n\}$ and we may render the connexion of $1 + \frac{1}{2} + \dots + \frac{1}{n}$ and $\log n + \text{const.} + An^{-1} + \dots$ a part of elementary algebra by easy processes. And similarly for $\log 1 + \dots + \log n$ and $n \log n - n$, and generally for $\Sigma \phi n$ and $\Sigma \int_n^{n+1} \phi x dx$.

2. I have looked through elementary writings in vain for a classification of the species of spherical triangles, as to character of sides and angles, with respect to the right angle. Excluding the right-angle, the cases which exist are as follows: all cases in which opposite sides and angles are of the same name; and all others in which an odd number of acute sides is

* The substance of this paper was read to the Society on the 7th of December, as stated at the commencement.

joined with an odd number of obtuse angles, except only three acute sides joined with three obtuse angles. This may be remembered by the following mnemonic diagram.



or two *N*s with an inverted *N* between them. The numerals, from left to right, describe the numbers of obtuse sides and of obtuse angles; from right to left, acute sides and acute angles; the lines connecting numerals assert the possibility of the combination. Thus, with two obtuse sides may coexist either one, two, or three obtuse angles; with two acute angles may coexist either one, two, or three acute sides.

The base of the triangle being given, and one of the hemispheres formed by its plane, the regions which are the loci of the vertices, for different classes of triangles, may be described as follows. Let the hemisphere be orthographically projected upon the plane of the base, and

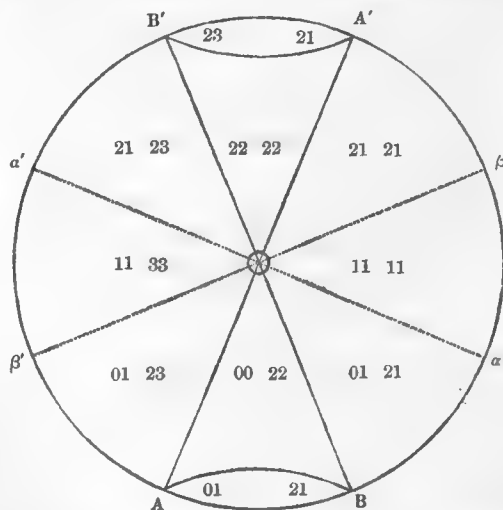

let orthographic projections be used for originals in description. Let *AB* be the base when acute, *BA'* when obtuse. Let *aa'*, *ββ'* be perpendicular to *AA'*, *BB'*. Draw an hyperbola *AB*, *A'B'*, having *aa'*, *ββ'*, for asymptotes. Then *AA'*, *BB'*, *aa'*, *ββ'*, represent secondaries of *ABA'B'*, and *AB*, *A'B'*, represent intersections of the sphere with an hyperbolic cylinder. The hemisphere is divided into ten regions; and each region is the locus of the vertices of one class of triangles for the base *AB*, and of one class for the base *BA'*. A point on the hyperbola, on either branch, is the vertex of a right-angled triangle, be the base either *AB* or *BA'*. Thus, if the vertex *C* be taken within the region *BOα*, then, the base being *AB*, all the sides are acute, and the one angle *ABC* obtuse; or the triangle may be symbolised as 01, no obtuse side and one obtuse angle. But with reference to *BA'*, we have 21, two obtuse sides *A'B*, *A'C*, and one obtuse angle *A'CB*. These symbols are entered in the compartment *BOα*, and all the other compartments are treated accordingly.

A. DE M.

TRANSACTIONS
OF THE
CAMBRIDGE
PHILOSOPHICAL SOCIETY.

VOLUME X. PART II.

CAMBRIDGE:

PRINTED BY C. J. CLAY, M. A. AT THE UNIVERSITY PRESS;

AND SOLD BY

DEIGHTON, BELL AND CO. AND MACMILLAN AND CO. CAMBRIDGE;

BELL AND DALDY, LONDON.

M. DCCC. LXIV.

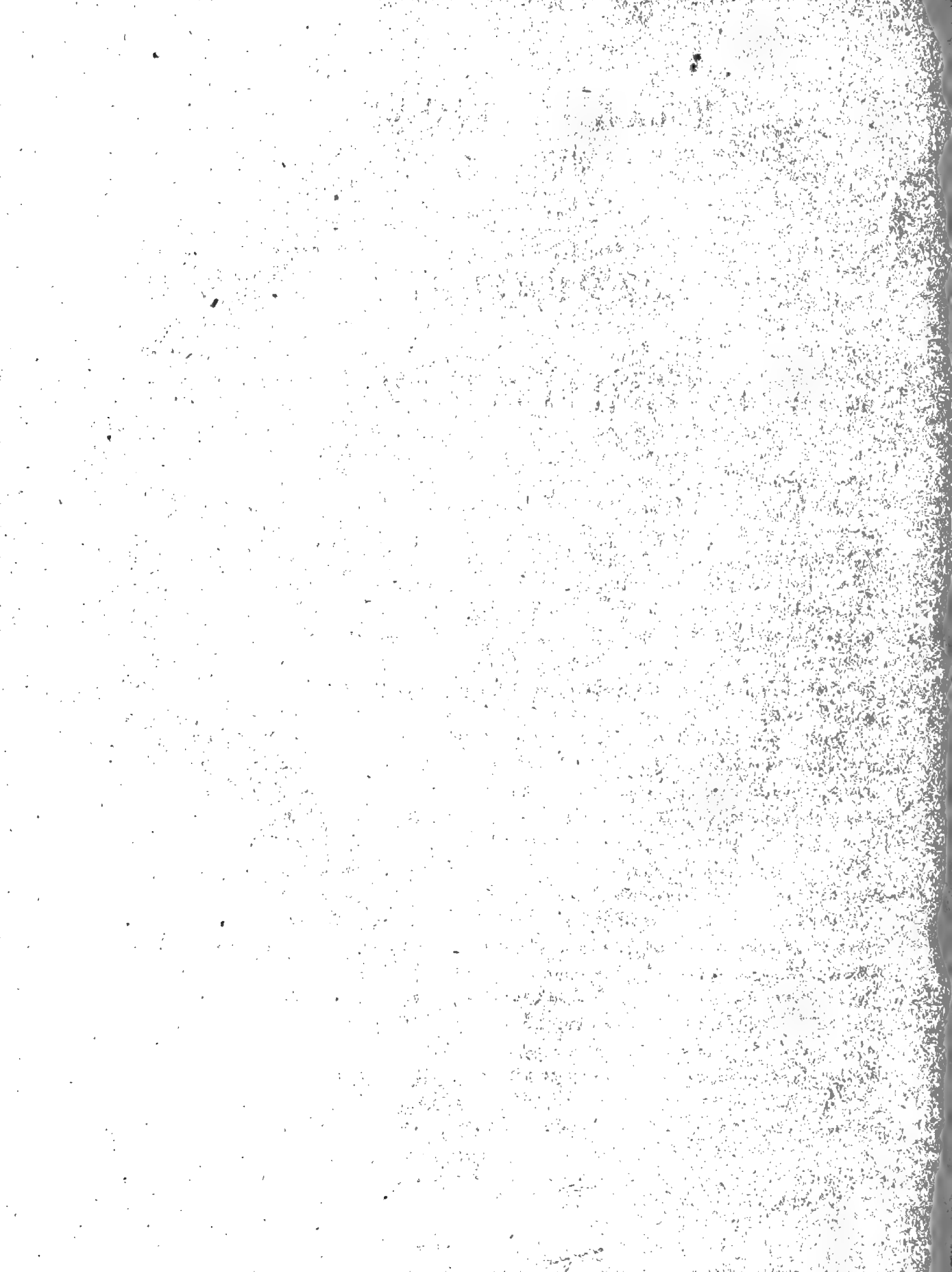

I. *On a Chart and Diagram for facilitating Great-Circle Sailing.**

By HUGH GODFRAY, M.A. *St John's College.*

[Read *May 10, 1858.*]

THE idea of navigating a ship on the arc of a great-circle, as being the shortest and most direct route, is not one of modern origin; it must, in fact, have presented itself to many minds simultaneously with the knowledge of the Earth's being a sphere; and we find that very early in the progress of navigation, its principles were fully understood and acted upon, and that before Mercator's invention it was employed for the guidance of vessels in distant voyages in preference to sailing on a Rhumb. But if we consider that logarithms were not yet invented, the amount of calculation must have been so great as very considerably to restrict its use; and it is not to be wondered at if the much simpler method given by Mercator should at once have found favour among mariners, and entirely superseded the laborious calculations which Great-circle sailing required.

Among other causes which would also tend to the disuse of the method would be the uncertainty of the ship's position in longitude, an element which ought to be known with tolerable accuracy, but which after only a few days sailing could not be much relied upon, even under the most favourable circumstances—absence of storms and of unknown currents. This would not affect sailing on a Rhumb so long as the same Rhumb course could be kept; but such would seldom be the case for any long distance,—and so the usual plan was to steer a course which would bring the ship to the latitude of the port bound to, or of any other point which it was considered desirable to make, and then sail due east or west on the parallel until the place was reached; and this method is even now frequently practised.

But it is most probable that what, more than any other circumstance, contributed to the neglect and ultimate rejection of Great-circle sailing, was the difficulty of ascertaining whether obstacles in the shape of land or rocks lay in the path. In Mercator's charts the whole track was *seen* on the map by merely drawing a straight line from the ship's place to her destination or to such other point as it was found desirable to attain; the mariner, by a mere inspection of this line, could see at once whether the track was one on which he could navigate, and if not, how far it was necessary to deviate from it.

This great advantage combined with the simplicity of the calculation will fully account for the universal adoption of the method, notwithstanding the greater distance which it was well known the ship would have to go over. In Great-circle sailing all that could be done for the same purpose was to determine with immense labour the position of a few points of the track, and, having marked these on the chart, to connect them by a curved line, the eye being made judge of the greater or less curvature that should be given in the intermediate spaces, so that the line should curve in a regular manner.

Of late there has been manifested a desire to revive the almost forgotten Great-circle sailing: the great extension of our commerce, and the constantly and rapidly increasing inter-

* Engraved by the Hydrographic Office, Admiralty. Published by J. D. Potter, 31, Poultry, Agent for the Admiralty Charts.

course with Australia and other distant parts of the earth, have rendered it desirable to shorten as much as possible these long voyages; and it is especially in long voyages that the advantages of sailing on a great-circle are most apparent.

The improvements also which have taken place in our ships and in our means of navigating them render this more practicable than in the days when a ship's longitude could be determined by dead reckoning only; the chronometer now has put it into the seaman's power to calculate that element with as much accuracy as his latitude; and so great is the confidence placed in the results, that cases are known where, when once in the open sea, no other reckoning has been kept but that of steering a course, the position of the ship being ascertained by daily observations, and distances run, leeway, currents entirely disregarded.

The introduction of steam vessels for Ocean navigation thereby enabling a mariner to shape his course and lay the ship's head whichever way he pleases, independent, in a great measure, of winds fair or foul, would again lead men to think of the direct course and shortest route, although, as we shall see when speaking of windward sailing, the advantages of the method are still greater to sailing vessels beating against a head wind.

We find consequently that within the last ten or twelve years various methods have been proposed for simplifying the calculations which determine the course to be followed, and most of them also give directions for determining, with more or less accuracy, the latitudes and longitudes of a few positions on the track generally at intervals of 5° of longitude.

But still, it is not favourably received:—a few of the more intelligent captains occasionally adopt it, but others equally intelligent, if they do not actually speak of it disparagingly, say that the difficulty attending its use will always render it of little practical value; and for the great majority of our merchant captains, who have little time and still less inclination for lengthy calculations or intricate manipulations, Mercator's sailing has advantages too obvious to be overlooked.

The fact is, that the main objection still exists in all its force: the track is not seen on the chart except in a greatly distorted form, and even this can be obtained only by a long and tedious operation which after all gives only a few positions; and, as the ship is nearly certain to deviate from this track in the course of a few hours, the operation would have to be repeated every day if not oftener. The course to be steered can be obtained with comparative facility, but by itself it tells nothing of the dangers ahead, and without the chart-track the ship may be blindly running to destruction.

So strongly is this difficulty felt that even the advocates of great-circle sailing recommend avoiding great-circle tracks which pass near groups of islands, whereas when using Mercator's sailing and guided by Mercator's charts, no such recommendation is considered necessary.

While considering this subject it occurred to me that charts constructed on the *Central* or *Gnomonic Projection* would exactly meet this difficulty, and would in Great-circle sailing answer the same purpose that Mercator's charts do in Rhumb sailing. All great-circles would be represented by straight lines, and *to see the ship's track we should merely have to draw a straight line from the ship's place to her destination.*

It may perhaps excite surprise that so obvious a solution should not have presented itself before, especially as this projection had already been applied to celestial maps, and even, as I have since learnt, to terrestrial maps on a small scale*—maps, however, intended only for the study of the geography of the globe, and not at all adapted to the wants of the mariner,—they were not charts, and there was no provision made for the determination of the course from one point to another. On Mercator's charts the Rhumb course is the angle made by the track with the meridian, and is seen at once by drawing a parallel through the nearest compass-rose, of which several are always traced on the chart; but this is not the case with charts on the Central Projection: a N.E. course, for instance, will not bisect the angle between the north and the east although these are at right angles to one another when the Pole is the centre of projection, nor yet will the N.E. course make a constant angle with the meridian lines; its value will be ever changing with the latitude, and the same will be true of all other courses.

Now in celestial or in geographical maps the courses are of no consequence, it is more important that those stars or towns which are on the same great-circle should be readily found. But, to the mariner who *must* guide himself by the compass, any chart which does not at once indicate the Rhumb course is almost useless. Mercator's chart gives at once a track (though not the shortest) and the course to be steered; and these are the two elements absolutely necessary,—without the track the ship might run into dangers, and without the course the track cannot be followed.

This may perhaps explain why such a simple projection as the central which satisfies one of the conditions of the Great-circle Problem, and that condition the very important one of indicating the direct and shortest track by merely drawing a straight line, should never have been applied to charts. It does not give the series of courses to be followed, nor even the first one on which to set out.

The various methods hitherto proposed for simplifying Great-circle sailing have all been directed to the determination of these courses, and where any attempt has been made at drawing the track it has always been on a Mercator's chart. My own ideas at first took the same direction, and I aimed at inventing some instrument which would trace the track on Mercator's chart by a continuous motion; but I gave this up as soon as it occurred to me to try the central projection. By the addition of a diagram I have made this projection answer all the conditions of Great-circle sailing with as much, if not more, facility than Mercator's chart does for sailing on a Rhumb: the track is *seen* a straight line, and this being drawn, the various courses and the distances to be run upon each are obtained, as also the distance from the ship to her destination, by a mere inspection of the diagram; and the chart can be used like an ordinary one for pricking off the ship's place day by day.

Windward Sailing.

I have stated before that the advantages of Great-circle sailing were not confined to steamers, and that sailing vessels when beating against a head-wind might derive still more benefit from it.

* Published by the Society for the Diffusion of Useful Knowledge.

These advantages are clearly explained in an able article on Great-circle Sailing in the Nautical Magazine for 1847, p. 228, from which the substance of some of the following remarks has been extracted.

1. Suppose two vessels together in the southern hemisphere bound to a place situated to the east on the same parallel, the wind also being due east. *A* who guides himself by Mercator's sailing will consider the wind as being right ahead, and will be as likely to put his ship on the one tack as on the other; while *B* who sails on a great-circle will see that the wind is not exactly a head-wind, for his course may differ 1, 2, or even in extreme cases 5 or 6 points towards the south;—let it be only 1 point, that is E. b. S., and suppose his ship to sail within $6\frac{1}{2}$ points of the wind. He will then choose the port-tack, that being only $5\frac{1}{2}$ points from his course, whereas the starboard-tack is $7\frac{1}{2}$ points away; so that on the port-tack he will by running 100 miles be 47 miles nearer to his destination, while on the other tack, a run of 100 miles will diminish his distance by $9\frac{3}{4}$ miles only.

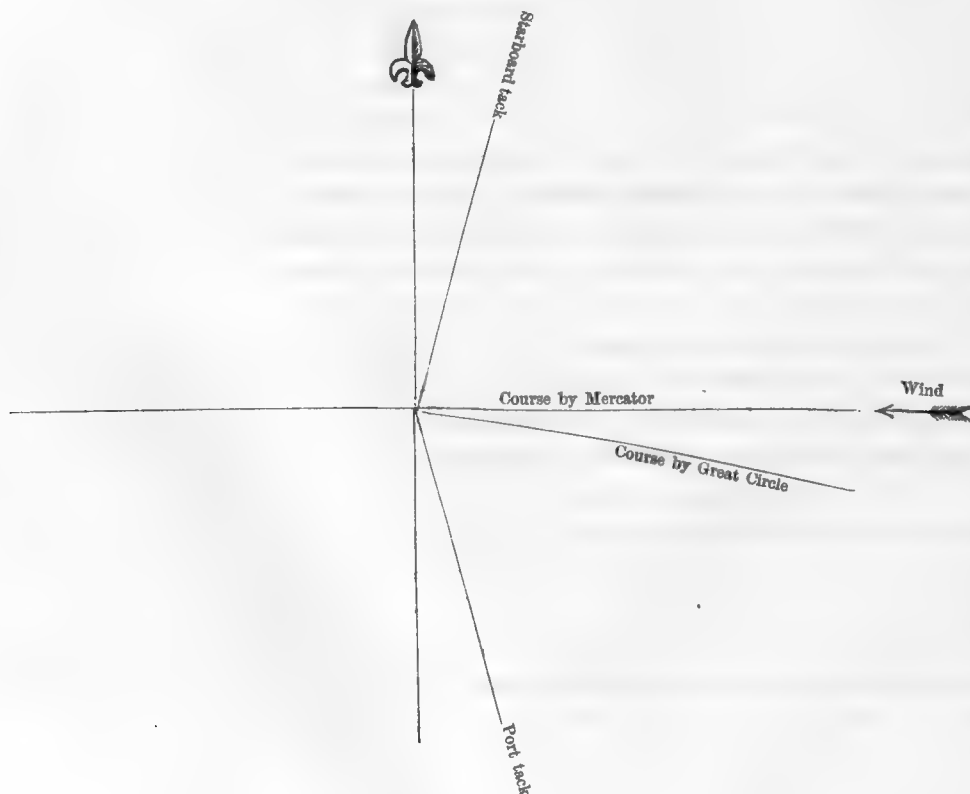

We have supposed the wind due east, so that the seaman *A* is as likely to select one tack as the other, but if the wind blow from any point between the course by Mercator and the great-circle course, he will be sure to select the wrong one.

It is true these tacks will not be persevered in; for both *A* and *B* know that a course which does not lead direct to the destination must gradually become less and less favourable, until at length it becomes desirable to adopt the other tack; but *B* will know when to make this change, and *A*, with the same object in view, will either start on the wrong tack, or abandon the right one too soon, or else persevere in it too long after it has become the wrong one.

2. The difference of distance between two places as measured on a great-circle or on a Rhumb course may in some instances be very small, although the two tracks differ considerably in position.

For instance: from Cape Clear in $\left\{ \begin{array}{l} \text{lat. } 51^{\circ} 26' \text{ N} \\ \text{long. } 9^{\circ} 29' \text{ W} \end{array} \right\}$ to Cape Race in $\left\{ \begin{array}{l} \text{lat. } 46^{\circ} 40' \text{ N} \\ \text{long. } 53^{\circ} 8' \text{ W} \end{array} \right\}$,

the distance by Mercator is 1738 miles,

and by Great-circle ... 1714 ...

so that the difference is only 24 miles, but at starting

the course by Mercator is S. $80^{\circ} 32'$ W,

and by Great-circle is N. $82^{\circ} 11'$ W,

which differ by $17^{\circ} 7'$, or rather more than $1\frac{1}{2}$ points.

Now 24 miles is a run of 2 or 3 hours, and this, with a fair wind or for a steamer, is the advantage to be derived from the adoption of Great-circle sailing in this particular instance; but suppose a sailing vessel beating against a contrary wind, the advantages will be far greater. The difference of $1\frac{1}{2}$ points between the courses at starting may allow a ship running within $6\frac{1}{2}$ points of the wind to steer 5 points from her course, if that course be the great-circle and the wind blow from the Rhumb; and therefore in a day's run of say 120 miles the 1714 miles will be reduced to about 1647, a decrease of 67 miles. But a second ship also running within $6\frac{1}{2}$ points and selecting the other tack, which according to Mercator appears equally favourable, will be steering at right angles to the great-circle course, and at the end of the 24 hours this ship instead of having gained will actually be a little further from Cape Race than at the commencement. On the next day this second ship will be put on the other tack, which will now be the correct one, and at the end of this day will have gained some 67 miles, that is, be about the same distance from her destination as the other ship was at the end of the first day.

Here then we see that one day out of two is lost by not adopting Great-circle sailing. The differences will not be so great when the vessels come near the place of destination; but on the whole there will be a gain of 4 or 5 days, and this merely from Cape Clear to Cape Race.

In this instance the two tracks are about 140 miles apart at their widest separation, and the value of Great-circle sailing is shewn by that which is the proper way of estimating it, viz. the gain in time,—the difference of 24 miles would otherwise be comparatively unimportant. In crossing the Pacific under similar circumstances of contrary winds the gain might extend to from 30 to 40 days.

3. There are other cases where the adoption of the great-circle course would have advantages independent of the diminished distance. Suppose in the previous example that the wind instead of being right ahead of the Mercator's course is $6\frac{1}{2}$ points to the south of it, so

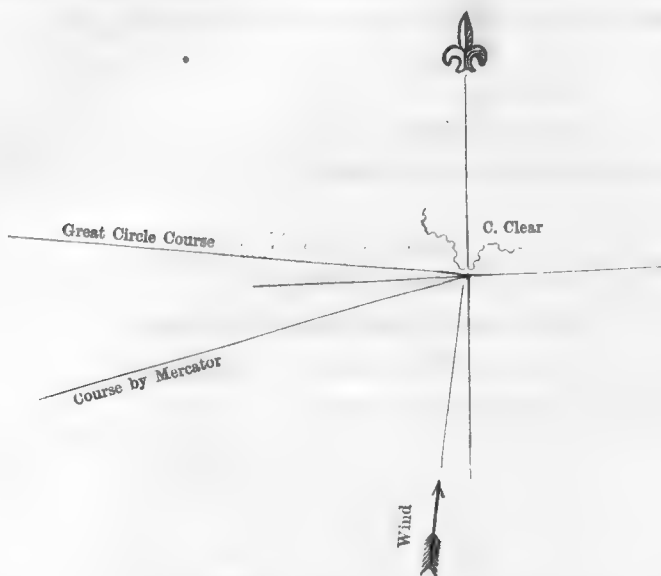

that the two vessels may adopt their respective courses, the second being close hauled and the other $1\frac{1}{2}$ points more away: then assuming their sailing qualities to be the same under similar circumstances, that which is close hauled will not make so much head-way as the other, and at the end of the day the Mercator's distance will have been diminished by 120 miles, the other by probably 130 or more—thus adding 10 miles to the original difference of 24.

4. It may sometimes happen that an island or a group of islands lies precisely in the ship's track as found by Mercator, and the sailor, obliged to deviate from it, will, without doubt, supposing all other circumstances equally favourable, choose that direction which seems to separate him less from the original track, and by so doing often take a longer route when one considerably shorter is open to him; and it is also important to remark, that not only is every course which lies between the Rhumb track and the great-circle shorter than the former, but that he may go to an equal distance on the other side of the great-circle and still have distances shorter than the Rhumb.

For instance: suppose a ship bound from New York to Gibraltar. It will be found by reference to Mercator's chart that the Rhumb track passes through the group of the Azores a little to the north of Santa Maria, the southernmost island. Supposing then that the ship-master guided by this chart wished to give the islands a wide berth, he would sail to the southward of Santa Maria and thus leave the whole group to the northward. But if we trace the track from New York to Gibraltar on the great-circle chart, we find that it passes some 180 miles to the north of the most northerly of the whole group and about 270 miles north of

Santa Maria; and therefore, from the remark in the previous paragraph, the ship might go 270 miles still further north and not make its route longer than that which would probably be chosen.

I am aware that the example I have selected is not a very good one, for the winds which prevail during the greater part of the year, and the presence of the Gulf-stream, may induce a ship-master to pass to the northward, and thus unconsciously approach the shortest track unless the vessel be a steamer, which probably would be kept on the southward course. However, this will serve to illustrate what may occur in similar cases in those parts of the world where the winds and currents would not influence the choice of the vessel's route.

I need not dwell any longer on the practical value of Great-circle sailing to the seaman. In distant voyages, as to Australia or New Zealand, its use will abridge the distance by several hundred miles, more than 1000 in some cases, and in shorter journeys where the gain in distance is small, the gain in time may, as we have seen, be considerable.

In the particular case of the voyage to Australia, there is another advantage which may possibly occur also elsewhere:—when the trade-winds in the Southern Atlantic have been cleared, if the course be shaped by Mercator, the ship will have to run through a region where storms are frequent, almost permanent; but if a great-circle course be adopted, or rather what has been called a composite course, which will be presently explained, a higher southern latitude is reached where the wind is usually favourable, storms of rare occurrence—and the distance perhaps 1000 miles shorter.

It is very possible to find routes where the great-circle course would be the stormy one and Mercator's free, and there are frequent cases too in which even Mercator's track is abandoned for a longer one, to take advantage of well-known ocean currents or prevalent winds such as the Trades. It is not to be expected, nor indeed to be desired, that Great-circle sailing should supersede the methods now in use, but it is very desirable that it should form a part of the sailor's nautical knowledge, not necessarily for him to adopt in all cases, but that he may know which is the shortest route, that he may see it on his chart, and that he may be able to follow it if his judgment tells him it is both practicable and preferable.

Composite Sailing.

There is yet another and a very simple case of Great-circle sailing, or rather a modification of it, to which reference was made just now. It is called composite sailing, and presents itself whenever the great-circle track reaches too high a latitude where the ice renders it dangerous or impossible for the ship to penetrate. In that case some one parallel of latitude is fixed upon for the maximum; and the shortest route, under these conditions, will consist of a portion of that parallel and of the portions of two great circles which are tangents to it, and pass one through the ship, the other through the destination. On the great circle chart the track will be the two straight lines drawn from the two places so as to touch the circle of highest latitude, and the part of this circle between the points of contact. This combination of great-circle sailing and parallel sailing offers therefore no difficulty. If the ship is driven into a higher latitude than that which was intended it must be left to the ship-master's own

discretion whether he will continue on the parallel so attained, which would then be the shortest track, or return to that first fixed upon.

Construction of the Chart.

The Pole is made the centre of projection, and a series of concentric circles will represent the parallels of latitude, the radius of any parallel being $r \cot (\text{lat.})$, where r is any convenient linear magnitude and equals the radius of the parallel of 45° . The meridians are straight lines drawn from the centre dividing each circumference into 360 equal parts. Any one of these being selected for the meridian of Greenwich, the coast-lines of the different countries may be then traced in the usual manner by means of the latitude and longitude of the different points.

The magnitude of the circles increases so rapidly in low latitudes,—becoming infinite at the equator,—that it is impossible to bring in the equatorial regions when the Pole is made the centre of the chart, and even the 10th parallel of latitude cannot be introduced into any moderate sized sheet without making the higher latitudes indistinct from their reduced dimensions.

But there are two reasons which render it perfectly unnecessary to introduce any portion of the inter-tropical regions. The first is that the difference between the track by great-circle and by Mercator is so small both as to length and as to position when a ship has to cross or to approach the Equator, that the one sailing has no practical advantage over the other. But the circumstance which more especially renders the rules of great-circle sailing unimportant in low latitudes is the presence of the trade-winds, which extend to from 20° to 25° on each side of the Equator. Every method must be subservient to these well-known currents of our atmosphere, and any chart which gives the correct outline of the continents and allows the sailor to mark down the ship's position day by day, will answer his purpose, whether it be a Great-circle, a Mercator, or even a Plane chart. There will be no sensible difference between his courses whether determined by Mercator, great-circle, middle latitude, or Plane sailing; for he will have to shape his course for comparatively short distances at a time, in order to reach certain positions which experience has proved will enable him to derive the greatest advantage or the least injury from the trade-winds and from those calms, the Doldrums, which prevail near the Equator.

Therefore since numerous charts for these regions have been published on Mercator's projection, there is no necessity for introducing others which have no advantage to offer. As I have already stated, Great-circle sailing must not be considered as a substitute for Mercator's, but as an auxiliary to be employed when the judgment of the seaman tells him it would shorten his voyage to do so.

If however great-circle charts were desired which would include the Equatorial regions, we should merely have to take for our centre some point in the Equator. In such a chart the meridians would be parallel straight lines, and the parallels of latitude would be represented by hyperbolas.

If a point not in the equator were taken for centre, the meridians would be converging straight lines and the parallels would be hyperbolas and ellipses. There is no need to enter upon any investigation of them here.

Description of the Course and Distance Diagram.

The object of this diagram is, as its name implies, to determine the course or rather the succession of courses which the ship must follow to keep on the great-circle track and the distance from any one point on the chart to any other.

It must, in the first place, be noted that the course on a great circle, i.e. the angle made with the meridian, changes continually from point to point. Now, it would be impossible for a ship, with the compass for its guide, to be put on this ever-varying course;—the helmsman must be told on what course to steer, and may be instructed to alter it after running a certain number of miles or a certain time; but to alter it every instant according to a definite law would be altogether impossible. The nearest quarter-point is the greatest amount of nicety ever aimed at, and he is a good helmsman who can secure that under the most favourable circumstances.

I have constructed this diagram so as to give the quarter-point nearest to the true course, and also the distance to be run on that quarter-point before the next one is substituted for it. The course can therefore never be more than $\frac{1}{8}$ th of a point in error, and while running one of these distances the error will be one way during the first half and the other way in the second, vanishing altogether about the middle, so that the compensation will be nearly perfect, and the route thus marked out will not perceptibly differ in length or in position from the real great-circle track.

The diagram consists of a series of concentric curves corresponding to the parallels of latitude, bounded by a horizontal and a vertical line; the degrees of latitude are marked on the latter, and the distances from the highest latitude on the former at intervals of 100 nautical miles, or any other convenient number, according to the size of the diagram, and through the various points of division are drawn horizontal and vertical straight lines over the whole figure.

All these are again intersected by 32 curve lines, the spaces between which are alternately light and shaded, marked in points and quarter-points for the determination of the courses. Before explaining the construction of these curves I shall proceed to shew how the diagram is to be used in the solution of the great-circle problem.

Use of the Chart and Diagram.

PROB. *Given the latitudes and longitudes of the ship and of her destination, to find the courses and distances to be run in order to follow the great-circle.*

Find the ship's place on the Chart and join it by a straight line with the port or place bound to [a thread stretched from the one place to the other will be the most convenient and simplest way]. This will be the great-circle track.

Note the direction of the track near the ship's place, i.e. whether from N. or S. towards E. or W.

Note also the *highest latitude* of the track, i.e. the latitude of the place where (produced if necessary) it approaches nearest to the pole.

[This will always be found with sufficient accuracy by a mere inspection of the Chart, but the exact point may be obtained by letting fall a perpendicular from the Pole on the track.]

Now refer to the diagram, and, along the horizontal line corresponding to the highest latitude, find the point where it intersects the curve corresponding to the latitude of the ship. This point, which may be called the *Ship's place on the Diagram*, will fall in one of the light or shaded spaces, and will indicate the course to be steered in points and quarter-points, from N. or S. towards E. or W., as previously found; and at the same time its position relatively to the vertical lines will give the distance from the highest latitude in miles.

We must, in the next place, determine how far the ship must run upon the course so found; and this will be done by proceeding along the horizontal line which represents the ship's course on the diagram (going towards the increasing or decreasing latitudes as the track on the chart will indicate), until we reach the light or shaded space corresponding to the next quarter-point. The difference between the two corresponding numbers at the top of the diagram will be the distance to run on that first course, but it will be found easier to measure the distance with a pair of compasses and apply it to the small scale of Nautical Miles at the bottom of the diagram; and in the same manner may the distances to be run on the successive courses be known.

This may be done for the whole track, but since it will be almost impossible to keep the ship on the exact track during the entire voyage, the first two or three courses and distances will be sufficient, and the whole operation being so simple and rapid, had better be repeated each day with the new position of the ship.

In just the same manner as the distance of the ship from the *highest latitude* has been found, may the distance of the other place be determined; and the sum of the two distances when the highest latitude falls between the places, or their difference when not, will be the distance of the one place from the other.

The course curves are traced so as to give the nearest quarter-point. They are exact for the middle of each space, and the separation between a light and a shaded space corresponds accurately to the intermediate eighth. Thus the boundary line between the $5\frac{1}{2}$ shaded and the $5\frac{3}{4}$ light spaces corresponds exactly to $5\frac{5}{8}$ points. By multiplying the number of spaces there would be no difficulty in further reducing the maximum error; but, as we have before stated, such accuracy would be superfluous.

I shall give one or two examples to illustrate the foregoing instructions.

Ex. 1. *To find the courses and distances on a great circle from Cape Agulhas, the Southern extremity of Africa, to Perth in Australia.*

Having drawn the track on the chart it will be seen that the highest latitude is $44\frac{3}{4}^{\circ}$, and the track is a practicable one.

Now refer to the diagram and find the point where the horizontal line through $44\frac{3}{4}^{\circ}$ is crossed by the curve of 35° , the latitude of Cape Agulhas. This point falls on the light space corresponding to $5\frac{1}{4}$ points. Hence the first course is S. $5\frac{1}{4}$ points E. or S.E. by E. $\frac{1}{4}$ E.; and the corresponding distance is 2130 miles from the highest latitude.

Then proceeding along the horizontal line towards the highest latitude, measure the breadths of the successive light and shaded spaces and the following series of courses and distances will be obtained :

S	$5\frac{1}{4}$	points E	45	miles.
S	$5\frac{1}{2}$...	E	253 ...
S	$5\frac{3}{4}$...	E	235 ...
S	6	...	E	220 ...
S	$6\frac{1}{4}$...	E	208 ...
S	$6\frac{1}{2}$...	E	197 ...
S	$6\frac{3}{4}$...	E	188 ...
S	7	...	E	181 ...
S	$7\frac{1}{4}$...	E	176 ...
S	$7\frac{1}{2}$...	E	173 ...
S	$7\frac{3}{4}$...	E	171 ...
		East	83	...

The highest latitude being now reached, the ship will have to go through the same courses and distances in an inverse order; but, as is evident from the chart, the courses will now run between the *North* and *East*, and the series will be,

		East	83	miles.
N	$7\frac{3}{4}$	points E	171	...
N	$7\frac{1}{2}$...	E	173 ...
N	$7\frac{1}{4}$...	E	176 ...
N	7	...	E	181 ...
N	$6\frac{3}{4}$...	E	188 ...
		&c.		

until the latitude of Perth 32° is reached, which, as the diagram shews, will be at 2465 miles from the highest latitude. The total distance is therefore 4595 miles, which is 204 miles less than by Mercator, and the first course by Mercator would be N. $87^\circ 59'$ E., differing nearly 3 points from that by great circle.

I have given all the courses and distances from Cape Agulhas up to and even from beyond the highest latitude, but in actual practice the first two or three alone would be required.

Ex. 2. *A ship in lat. 30° S., long. 18° W. is bound to Melbourne.*

The great-circle track will here be found to reach $77\frac{1}{2}^\circ$ South, and is consequently impracticable. Suppose 55° to be the highest latitude decided on.

Since the highest latitude is known, the courses and distances can at once be found by the diagram.

The intersection of the horizontal line through 55° with the parallel of the ship 30° falls on the course $3\frac{3}{4}$ points at a distance 3140 miles.

Hence the first course is S. $3\frac{3}{4}$ E. or S.E. $\frac{1}{4}$ S.

And by examining the distances at which the changes of course take place, we find that the ship must run 305 miles on this course, then 330 miles on the course S. 4 points E. &c.; but to see whether these courses are practicable or not, we must refer to the chart.

From the ship's place on the chart draw a straight line to touch the latitude circle of 55° , this it does at \odot . From Melbourne draw a straight line to touch the same parallel at \oplus . These two straight lines and the part of the intercepted parallel from \odot to \oplus constitute the track. The portion from \odot to \oplus being due East.

The lengths of the two parts from the ship to \odot and from \oplus to Melbourne may be determined as before by the diagram. The portion of the parallel from \odot to \oplus is very simply obtained by the usual rules for parallel sailing.

The total distance will be found 7003 miles,
 being 400 miles longer than the direct great-circle track,
 and 1130 miles shorter than the Rhumb track.

The difference between the first course from the ship to \odot and the course by the Rhumb would be $35^\circ. 14'$, or nearly $3\frac{1}{4}$ points.

Construction of the Course and Latitude Curves.

It will not be difficult now to understand how the curves are traced in the diagram. At the highest latitude of a great-circle track, the course is evidently due East or West, and as we move along the track away from the highest latitude, we shall find the course altering continuously as the distance alters, the connexion between the course and the distance being determined by the solution of a right-angled spherical triangle.

If λ be the given *highest latitude*,
 d the distance in nautical miles from the highest latitude,
 θ the course or angle made by the track with the meridian at that distance,

we have $\sin \frac{d}{60} = \cot \theta \cot \lambda \dots \dots \dots (1),$

which determines the distance of the point where the course is θ ; and the curve for the course θ in the diagram must pass through that point where the horizontal line corresponding to the *highest latitude* λ is met by the vertical line at distance d .

If we thus determine the distance d for the course θ on each horizontal line we have a series of points through which the curve may be drawn.

The latitude quadrants are traced in a similar manner:—

If λ be the highest latitude of a great-circle track,
 λ' ... any other lower latitude on this track,
 n ... the number of nautical miles between them,

we find $\sin \lambda' = \sin \lambda \cos \frac{n}{60},$
 $\therefore \cos \frac{n}{60} = \sin \lambda' \operatorname{cosec} \lambda \dots \dots \dots (2),$

which determines n , the distance at which the latitude curve λ' crosses the horizontal line λ .

II. *Suggestion of a Proof of the Theorem that every Algebraic Equation has a Root.* By G. B. AIRY, ESQ. *Astronomer Royal.*

[Read Dec. 6, 1858.]

IN reading Professor De Morgan's demonstration of the existence of a root in every algebraic equation, contained in a Paper lately communicated to this Society (a demonstration which is not to be mastered without very close attention), it occurred to me that a different proof might be furnished, based on the same principle of comparing the values of P and Q when r is very small and when r is very great, but dispensing entirely with the chain of signs and its changes; using, moreover, instead of the geometrical reference in Professor De Morgan's proof, a geometrical reference of different character which admits of being placed more distinctly before the eye; and thus answering more perfectly to the etymological meaning of "demonstration," namely, "clear exhibition." As the possession of this proof has supplied to my own mind a satisfactory hold of a most important theorem which I have sought in vain for many years, I have thought that it would not be presumptuous in me to place it before the Society, in the hope that it may tend to satisfy, with other students of Algebra, a want which I have myself felt so long.

1. In order to take the subject in its utmost generality (which, however, scarcely alters the steps of the demonstration), I shall, with Professor De Morgan, suppose the equation to be

$$a_\alpha r_\theta^\alpha + b_\beta r_\theta^{\beta-1} + \dots + m_\mu = 0,$$

where the coefficients $a_\alpha, b_\beta, \dots, m_\mu$, may contain imaginary as well as real quantities. I shall also follow his notation in thus changing the form of the terms:

Let

$$a_\alpha = a (\cos \alpha + \sin \alpha \sqrt{-1}),$$

$$b_\beta = b (\cos \beta + \sin \beta \sqrt{-1}),$$

.....

$$m_\mu = m (\cos \mu + \sin \mu \sqrt{-1}),$$

and also

$$r_\theta = r (\cos \theta + \sin \theta \sqrt{-1}),$$

where $a, b, \&c., \alpha, \beta, \&c., m, \mu$, are known constants, and r and θ are yet to be determined. When the coefficients of the equation are entirely real, $\alpha, \beta, \&c., \mu$, are = 0.

Substituting these new quantities in the equation, it becomes

$$P + Q\sqrt{-1} = 0;$$

where $P = ar^n \cos(n\theta + a) + br^{n-1} \cos\{(n-1)\theta + \beta\} + \dots + m \cos \mu,$

$$Q = ar^n \sin(n\theta + a) + br^{n-1} \sin\{(n-1)\theta + \beta\} + \dots + m \sin \mu.$$

And the problem of discovering a root of the equation is reduced to this, To find values for r and θ which shall make P and Q simultaneously = 0.

2. The theorem of proving the existence of a root of the equation will therefore be reduced to this: It is to be shewn that, upon trying all values of r between 0 and positive infinity, and all values of θ between 0 and 2π , there will certainly be at least one value of r and one value of θ which, used in combination, will make both P and $Q = 0$. It will be found unnecessary to make trial of negative values of r , because (the equation being of an even order) they will give the same results in the first terms of P and Q as the positive values, and because, in the demonstration, their effects on the other terms will be unimportant. Moreover, in every term of P and Q , the effect of a change of sign of r may also be produced by retaining the sign of r and altering the value of θ by π ; a change which will merely produce results contained among those now to be mentioned.

3. It will be convenient to confine our attention, in the first instance, to values of θ included between those which make $n\theta + a = 0$, $n\theta + a = 2\pi$. But the same form of demonstration which applies to these will also apply to values

$$\text{between those which make } n\theta + a = 2\pi, \quad n\theta + a = 4\pi;$$

$$\text{between those which make } n\theta + a = 4\pi, \quad n\theta + a = 6\pi;$$

and so on, ending with $2n\pi$, after which the values of θ recur.

After the value $n\pi$ (n being necessarily even, and $n\pi$ therefore necessarily occurring as a limit of values of $n\theta + a$), the values of θ recur increased by the quantity π . The substitution of a certain value ρ for r with these values of θ amounts to exactly the same as the substitution of $-\rho$ for r with the former values of θ ; and thus the absence of all necessity for trial of negative values of r , to which allusion has been made above, is confirmed.

4. If we construct two curves, whose common abscissa is θ , and whose ordinates are the corresponding values of P and Q produced by substituting in their expressions the same value of r ; and if we vary the value of r ; then, upon increasing indefinitely the value of r , we shall increase indefinitely, and to an unmanageable magnitude, the ordinates representing P and Q . But, as all that we want in the subsequent demonstration depends upon the proportion of P and Q , we can adopt a device, similar to that introduced so successfully by Newton in the 1st Section of the *Principia*, but in the opposite sense; we can suppose every one of the ordinates for a given large value of r diminished in the same proportion, till the

maximum of these diminished ordinates has a value nearly independent of r ; and then we can contemplate with ease the relations of the two curves even when r is made indefinitely great.

5. As it is our object to prove that P and Q may become $= 0$ at the same time, it would at first seem best to discover the law which determines the intersections of the P -curve (or the curve connecting all the summits of the ordinates representing the value of P) with the line of abscissæ, and in like manner to discover the law which determines the intersections of the Q -curve (or the curve connecting all the summits of the ordinates representing the values of Q) with the line of abscissæ; and then to shew that intersections of the two curves with the line of abscissæ must at some time fall on the same point. But I believe that it will be easier to consider the intersections of the P -curve with the Q -curve, and to shew that, with some value of r , one of these intersections must have moved across the line of abscissæ. The process will therefore be,

To exhibit the forms of the P -curve and the Q -curve when $r = 0$.

To exhibit the forms of the P -curve and the Q -curve when r is indefinitely great.

To infer from these the general character of the formation of intersections, and change of the points of intersection, of the two curves.

To shew that, in some part of this change, one of the points of intersection must have crossed the line of abscissæ.

6. When $r = 0$, the P -curve is a straight line whose ordinate $= m \cos \mu$. When r is indefinitely great, the first term only in the value of P is sensible (as being indefinitely greater than the others); and the P -curve, with its ordinates diminished as is mentioned in Article 4, is a line of cosines, or a line of sines drawn back through $\frac{\pi}{2}$. And when $r = 0$, the Q -curve is a straight line whose ordinate $= m \sin \mu$: when r is indefinitely great, the first term only in the value of Q is sensible, and the Q -curve, with its ordinates diminished, is a line of sines. In conformity with these indications, the following diagrams are drawn: where $P(0)$ and $P(\infty)$ denote the P -curves corresponding respectively to $r = 0$, $r = \infty$; and $Q(0)$ and $Q(\infty)$ denote the Q -curves for $r = 0$, $r = \infty$. I have supposed that $m \cos \mu$ and $m \sin \mu$ are both positive, and that $m \sin \mu$ is smaller than $m \cos \mu$; but it will be seen in the demonstration that the relation of these magnitudes is unimportant; the two values may even coincide; the only condition which cannot be admitted is, that $P(0)$ and $Q(0)$ intersect at a single point, which indeed can never happen.

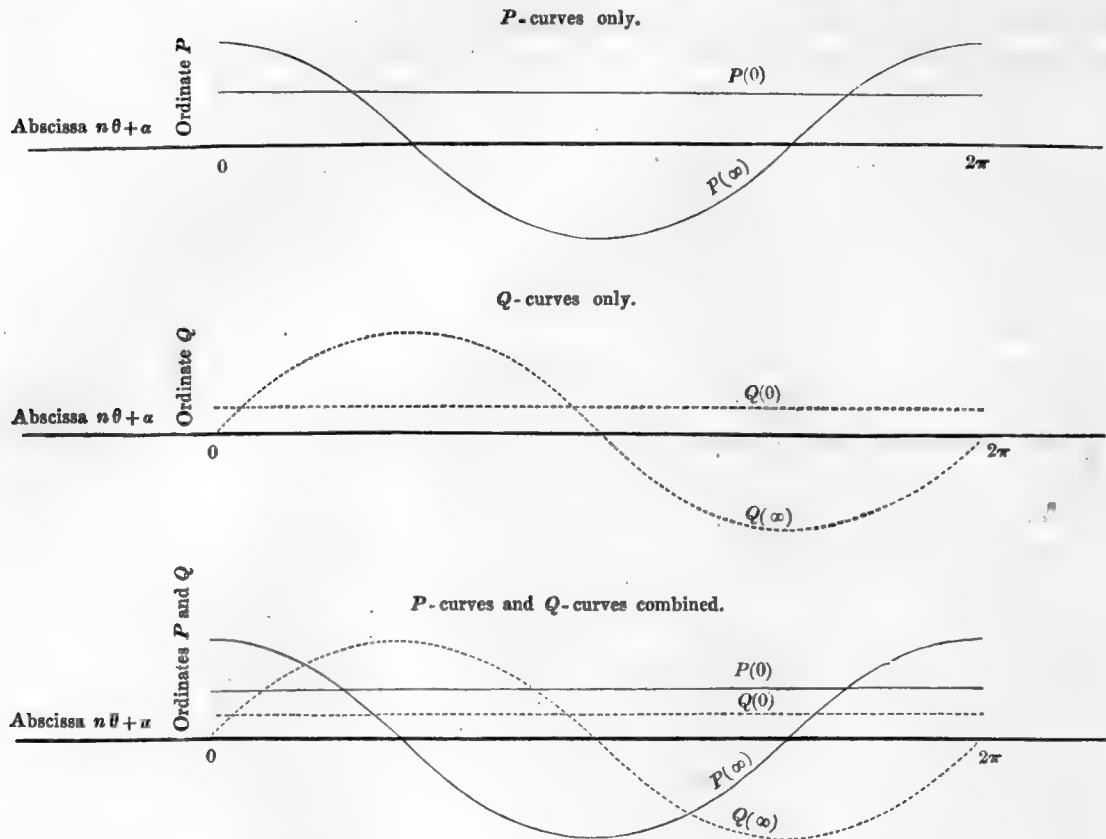

7. In these diagrams it is to be remarked,

- (1) That $P(0)$ and $Q(0)$ do not intersect.
- (2) That $P(\infty)$ and $Q(\infty)$ intersect in two points.
- (3) That one of these points of intersection is above the line of abscissæ, and the other is below it.

Let us now consider what must have happened in the change of relation of the P -curve and the Q -curve, while $P(0)$ was changing to $P(\infty)$ and $Q(0)$ to $Q(\infty)$.

8. We have preserved no record of the forms of the curves for values of r intermediate between 0 and ∞ , but we know that they will depend upon the terms of the expressions for P and Q which are intermediate between their first and last terms, and therefore will be different in different cases. But we see that some of the following Changes must have occurred in every case, while r was increasing from 0 to ∞ ;—

Change [1]. Either a *sinus* of the P -curve must have intruded upon the Q -curve (or *vice versa*) so as to produce two intersections.

Change [2]. Or the P -curve has intruded upon the Q -curve (or *vice versa*) in two *sinus* so as to produce four intersections; of which two have been subsequently obliterated.

Change [3]. Or a greater number n of such *sinus* have been formed, producing $2n$ intersections; and $2n - 2$ intersections have been subsequently obliterated.

I shall now consider the movement of the intersections while these formations and changes of *sinus* were going on.

9. In Change [1]; when one curve begins to intrude upon the other, it first intrudes on it by simple contact. If that contact occurs exactly on the line of abscissæ, the investigation is terminated; P and Q vanish together, and a root has been found for the equation. But if the contact does not occur on the line of abscissæ, it occurs (say) above it; as the intrusion advances, the simple contact is changed into two intersections, both above the line of abscissæ. But one intersection of $P(\infty)$ and $Q(\infty)$ is below the line of abscissæ. How can this have been formed? It can only have been formed by the downward-travelling of that intersection of the P -curve and Q -curve which was in fact the lower end of the *sinus* of intrusion, till it crossed the line of abscissæ to its lower side. At one instant therefore this intersection was on the line of abscissæ. At that instant, P and Q vanish simultaneously, and a root is found for the equation.

If the first contact of the two curves had occurred on the lower side of the line of abscissæ, the upper of the two intersections must have crossed the line of abscissæ to the upper side, in order to form the upper intersection of $P(\infty)$ and $Q(\infty)$; and the conclusion is the same.

It will be remarked that it is not necessary that the simple contact and the first formation of the *sinus* should commence in the diagram which is before us. They may have commenced in the diagrams to the right or to the left of that which is before us, and the intersections may then have travelled sideways into this diagram.

10. Change [2] may be effected in three ways. Either, when the two *sinus* have been formed, one of them may afterwards have been destroyed by the withdrawal of the protrusion that formed it; which leaves every thing in the same state as if it had never been formed, and therefore leaves the other *sinus* in the state of Change [1].

11. Or, when two *sinus* have formed four intersections, s, t, u, v ; two of these may have been lost, by the union of t, u , into a point of simple contact, and the subsequent separation of the curves there. In that case, if s, t, u, v , are all on the same side of the line of abscissæ, the union of t, u , and subsequent separation of curves, leave s, v , on the same side, and the reasoning of Change [1] applies. If s, t , are on one side and u, v , on the other side of the line of abscissæ, the approach of t to u forms an intersection upon the line of abscissæ, and a root is found.

12. Or, two intersections may have been lost by the sliding of s and v beyond the first and last limits of the diagram. In that case, if s, t, u, v , are all on the same side of the line of abscissæ, the disappearance of s, v , leaves t, u , subject to the reasoning of Change [1]. If s, t , are above, and u, v , below, s may slide off to the left of the diagram and v to the right, leaving t and u in the position proper for the final intersections of $P(\infty)$ and $Q(\infty)$, and then there will not necessarily be a root within the limits of this diagram; but on tracing the course of v into the next diagram (2π to 4π), which is exactly similar to this diagram (0 to 2π), it will be seen that v , which is now below the line of abscissæ, must rise above the line of abscissæ, and consequently it must cross the line of abscissæ; and therefore a root is ascertained. In like manner, in tracing the course of s backwards into the preceding diagram (-2π to 0), s , which is now above the line of abscissæ, must form an intersection below the line of abscissæ; and therefore it crosses the line of abscissæ, and therefore a root is ascertained.

13. Change [3] may in all cases be resolved into combinations of Change [1] and Change [2], and requires no special treatment.

14. The general reasoning, applicable to all cases, is this. As r increases from 0 towards ∞ , the intersections of the P -curve and the Q -curve must take place in pairs, the two intersections which constitute any pair being, in the first instance, on the *same* side of the line of abscissæ. But adjacent intersections of $P(\infty)$ and $Q(\infty)$ must in all cases be on *opposite* sides of the line of abscissæ. In the change from the former to the latter state, one of the two intersections which constitute a pair must cross the line of abscissæ; and thus there must be as many roots as there are couples of adjacent intersections of $P(\infty)$ and $Q(\infty)$; that is, as many roots as there are different diagrams; that is, there must be n roots.

15. It appears to me that this demonstration of the existence of roots of an equation is perfect and general.

16. Perhaps some steps will be made in fully understanding the nature of the changes of the intersections by consideration of an extreme case. Suppose that the equation is of the 10th order, and suppose that the roots are all imaginary, the real parts being all positive, and the proportion of the real part to the imaginary part being so nearly equal in all, that the values of θ for all will be included between $\frac{\pi}{5}$ and $\frac{2\pi}{5}$ (imaginary term positive), and between $\frac{8\pi}{5}$ and $\frac{9\pi}{5}$ (imaginary term negative). Then in the diagram (2π to 4π) there will be, on giving a sufficient value to r , ten intersections, five of which, on increasing the value of r , will cross the line of abscissæ, exhibiting five roots. In like manner, in the diagram (16π to 18π), there will be ten intersections, of which five will cross the line of abscissæ, exhibiting five roots. In the other diagrams there will

be no intersections at all. As the value of r is indefinitely increased, the intersections will spread away to the right and left, till finally there are two intersections and no more in every single diagram.

17. The existence of real roots of the equation depends on the contingency of intersection taking place upon the line of abscissæ at the point where $\theta=0$; or, supposing all the coefficients of the equation real, and therefore $\alpha=0$, it depends on the intersection taking place at the left-hand extremity of the diagram. Now with real coefficients, Q always vanishes when $\theta=0$; or, the Q -curve always intersects the line of abscissæ at the left-hand extremity of the diagram. If the last term of the equation be negative, $P(0)$ will be below the line of abscissæ; and the P -curve, in the course of its change to the state of $P(\infty)$, must pass through the left-hand extremity of the diagram, and therefore must make an intersection there with the Q -curve; and thus there will be a real positive root; as is otherwise abundantly known. The same reasoning applies in all respects when $\theta=\pi$ (the order of the equation being always supposed even): but in the interpretation of the result there will be this difference, that the root of the equation instead of being $r \cos 0$, as in the case just considered, will be $r \cos \pi$, or $-r$: and thus the equation will have a real negative root as well as a real positive root: as is also well known.

G. B. AIRY.

ROYAL OBSERVATORY, GREENWICH,
November 9, 1858.

III. *On the General Principles of which the Composition or Aggregation of Forces is a consequence.* By AUGUSTUS DE MORGAN, F.R.A.S. of Trinity College, Professor of Mathematics in University College, London.

[Read March 14, 1859.]

I CALL the junction here considered *aggregation*, not *composition*. The mode in which pressures or translations are put together differs from that in which ratios are put together in the manner illustrated in my last paper on logic (Vol. x. Part 1). Briefly, junction of two into one is *aggregation* when the vanishing of one does not prevent the other from producing its full effect: it is *composition* when the vanishing of either destroys the whole effect of the other also. Both are certainly *compositions*, if etymology have her rights; but the distinction must be drawn, and it is, I think, most conveniently made, and—all subjects considered, including logic—with least forcing of words, by the nomenclature I have proposed.

The words *possible* and *impossible* have been so misused, in the mathematical and logical sense, in the physical sense, and in the ambiguities arising from the double sense, that I am glad to dispense with them. By a *result of thought* I mean any statement to which we *must* assent, whether by consciousness alone, or by the action of the necessary *laws of thought* on postulates which consciousness must grant. Thus $a + b = b + a$ and $\int_1^x x^{-1} dx = \log x$ are equally results of thought: that the first is a pure axiom and the second an advanced theorem is, so far as we can see or know, a contingency of *our* minds, not a law of mind. There may be beings who cannot help granting the second, just as we cannot help granting the first. Self-evident things may be capable of deduction from others of the same kind: of this we shall see a remarkable instance.

By a *result of physics* I mean any statement which, though involving results of thought—which no result of physics is entirely without—also involves components which can be conceived as possible to be contradicted by experience, and which therefore are only furnished by experience; that is, total want of exception to them in the past originates full belief in their continuance for the future. The most deceptive phrase in our language is *physical impossibility*. There is no such thing. Owing to the mixture of result of thought and result of experience which obtains in every law of physics, it is easy to present, as a *physical impossibility*, what is in truth nothing but the contradiction of a result of thought. That the *unusual* or the *unprecedented* should take place during the continuance of the hitherto *usual*, is impossible: for other than that which is to be cannot come to pass. Make then a *law of*

nature, one ingredient of which is the assumption*, on grounds of pure thought, that the *will-be* shall agree with the *has-been*, and it shall be *impossible* that a stone shall refuse to fall to the ground. But the impossibility is no more than the impossibility of simultaneously obeying our law and disobeying it. These remarks are not out of place in an age in which we are told on high authority that we ought to set out in all physical investigations with a clear view of the naturally possible and impossible. We cannot do this even in logic and mathematics, the only true fields of the possible and impossible. A clear view of the *usages* of nature must, of course, existing up to a certain point, be augmented by reflexion, or further experiment, or both, up to a higher point: but no length of *usage* gives any odds in favour of the impossibility of the contrary. I am now setting out on a species of physical investigation not merely without a clear view of the possible and impossible, but by reason of the absence of that view, and with no other object than its attainment. The question is, a certain law of physics being given, to lay down the postulates on which it is founded, and to decide whether any contradiction of them be possible in thought, or whether all contradiction be impossible.

There are two subdivisions of our subject. In the first are all the cases in which actions are distinguished by magnitude and direction, as in the cases of translation, velocity, rotation about axes passing through one point, pressures producing either equilibrium or motion, moments of rotation producing either equilibrium or motion. In the second are rotations, &c. about parallel axes, pressures applied at different points in parallel directions, &c. In both these subdivisions there is a common form, with much variety of matter. In order to separate the common form, it will be necessary to invent terms which are independent of the material distinctions of the different cases.

By a *tendency* I mean anything which has both *magnitude* and *application*. By *application* I mean anything which, not giving the notion of magnitude, or of more and less, but containing the notion of *opposition*, makes the following postulates intelligible and true. In one of the subdivisions above named, different applications mean different *directions*: in the other, different *points of application of the same direction*. But it may be that there are yet other aggregations in which the word application has other meanings. Again, by the *aggregate* of two tendencies, I mean a third tendency which is singly *equivalent* to the first two acting jointly: and by *equivalence* I mean any notion which, subject to the condition that things equivalent to the same are equivalent to one another, also makes the four postulates intelligible and true. And, so long as the postulates exist, it is not necessary that the two tendencies

* All our perfect knowledge of the future is comprised in the certainty that it will, in due time, become the past, if existence continue, or, taking the Kantian doctrine, if *intelligent* existence continue. We add to this our mental conviction that what always has been will continue to be; nor can I deny that those who thus think have been justified by the result up to half-past eleven A. M. on the 9th of February, 1859. And if the laws of nature should continue unaltered till noon, the additional half hour will add a trifle to the *force* of their data. But the theory of probabilities, the only protector from false con-

clusions in such a case as the present, gives it as an undoubted result that, no matter how many our observations of permanence from moment to moment may be, so long as they are finite in number, we cannot, *from these observations alone*, draw any probability, however small, in favour of an *unlimited* continuance. Except by knowledge of continuance *ab infinito*, we cannot acquire any well grounded faith in continuance *ad infinitum*, from any observation and reasoning grounded on that observation alone.

which are aggregated should be of the same kind, nor that joint action should be *simultaneous* action.

The four postulates are as follows:—

1. Any two tendencies have one aggregate (0, the aggregate of counteraction, being included among possible cases), and one only.

2. The magnitude of the aggregate, and its application relatively to the applications of the aggregants, depend only on the relative, and not on the absolute, applications of the aggregants.

3. The order in which tendencies are aggregated, produces no effect either on the magnitude or application of the aggregate.

4. Tendencies of the same or opposite applications are aggregated by the law of algebraical addition.

Let a superfixed cross be the symbol of aggregation, the order of aggregation being the inverse of the order of writing. Thus $A \times B \times C$ signifies the aggregation of A with the aggregate of B and C , and is not distinguishable from $A \times (B \times C)$. The symbol A expresses both magnitude and application. The following propositions are now deducible from the postulates.

5. In any aggregate the result of partial aggregation may take the place of its own aggregants: thus $A \times B \times C \times D$ is $(A \times D) \times (C \times B)$. For, by 3, $A \times B \times C \times D$ is $A \times D \times C \times B$, or $A \times D \times (C \times B)$, or $(C \times B) \times A \times D$, or $(C \times B) \times (A \times D)$, or $(A \times D) \times (C \times B)$.

6. Two tendencies cannot counteract each other, that is, aggregate into the tendency 0, unless they have equal magnitudes and opposite applications. Let A and B be of equal magnitudes and opposite applications; and let M be any third tendency. If then $A \times M$ give 0, $B \times A \times M$ gives B . But, by 4, $B \times A$ gives 0, whence $B \times A \times M$ or (5) $M \times (B \times A)$ gives M . That is, by 1, B and M are identical: whence no other than B , the equal and opposite of A , gives 0 or counteracts A . Hence it follows that $-A$ and $-B$, the opposites of A and B , have $-(A \times B)$ for their aggregate. For $A, B, -A, -B$, giving $A \times (-A)$ and $B \times (-B)$, or 0 and 0, by 4, counteract each other: that is, $A \times B$ and $(-A \times -B)$ counteract; whence $(-A \times -B)$ and $-(A \times B)$ are identical.

7. An aggregate has *not more than* one pair of aggregants, when the applications of the aggregants are given, and are different. Let A and B , of given different applications, aggregate into C ; and let P and Q , severally of the same or opposite applications with A and B , have C also for their aggregate. Then $-P$ and $-Q$ give $-C$, by 6: whence $A \times B \times (-P) \times (-Q)$ give $C \times (-C)$, or 0. That is, by 3 and 4, $(A - P) \times (B - Q)$ is 0; which, by 6, $A - B$ and $P - Q$ being of different applications, cannot be, unless $A - P$ and $B - Q$ be severally 0.

8. If the aggregants be altered in any ratio, without change of application, the aggregate is altered in the same ratio, also without change of application. Let $A \times B$ be C : then, m being any integer, $(mA) \times (mB)$, where m affects only the magnitude, is by 4, $A \times A \times A \dots \times B \times B \times B \dots$ or, by 3, $A \times B \times A \times B \dots$, or, by 5, $C \times C \times C \dots$, or, by 4, mC . Again, if $\left(\frac{1}{n}A\right) \times \left(\frac{1}{n}B\right)$ give P , $A \times B$ is nP , or C is nP ; whence P is $\frac{1}{n}C$. Hence $\left(\frac{m}{n}A\right) \times \left(\frac{m}{n}B\right)$ is $\frac{m}{n}C$. Hence it follows that the ratios of the aggregants to the aggregate, and the relative application of the aggregate, depend solely on the ratio and relative applications of the aggregants.

9. Any tendency may be disaggregated into two of any two different applications, neither of which is its own: that this cannot be done in *more than* one way has been proved. Take any tendency of one of these applications; then, by taking another of sufficient smallness of the other application, an aggregate may be produced which shall be as nearly of the first application as we please. Again, since the relative application of the aggregate depends only on the *ratio* of the aggregants, by taking the second aggregant as great as we please, we may produce an aggregate as nearly of the second application as we please. Consequently, take what tendency of the first application we may, we can find another tendency of the second application such that the aggregate shall be of the same application as the tendency which it is required to disaggregate: and, by 8, alteration of these two aggregants in the proper ratio will give the aggregate the proper magnitude. In assuming tendencies to have *magnitude*, the law of continuity has also been assumed; which is mentioned here because this is the first place in which the assumption has taken effect.

We are now prepared to deduce the modes of aggregation when specific matter is added to the forms discussed above. Two cases arise: first, when by *application* we mean *direction*, from which we deduce the *diagonal law* of aggregation; secondly, when by *application* we mean *choice of a point at which to apply a given direction*, from which we deduce that law of inverse ratio which is commonly called the *principle of the lever*.

1. For the first case, any one of what are called proofs of the *parallelogram of forces* may be inserted. The whole proposition follows, in well known ways, so soon as it is proved for tendencies at right angles to one another. Let P and Q be two tendencies at right angles to one another, and let R be the aggregate, making an angle θ with P . Then, as shown, there exists such an equation as $P = R \phi \theta$. Let two equal tendencies, of magnitude P , be inclined to a certain axis in their plane at angles $x + y$ and $x - y$: then, from 2, the aggregate of P and P is inclined to this axis at the angle x , and to each of the aggregants at the angle y . Let P and P be disaggregated in the directions of their aggregate and its perpendicular: the perpendicular aggregants counteract each other, and each of the others is $P \phi y$; whence the aggregate is $2P \phi y$. Disaggregate the two tendencies and their aggregate in the directions of the axis and its perpendicular: the aggregants in the direction of the axis are $P \phi (x + y)$, $P \phi (x - y)$, and $2P \phi x \phi y$; whence

$$\phi (x + y) + \phi (x - y) = 2 \phi x \phi y.$$

This equation, differentiated twice with respect to x , and twice with respect to y , shows that $\phi''x : \phi x$ and $\phi''y : \phi y$ are equal, independently of all relation between x and y . Hence ϕx is $Ae^{mx} + Be^{-mx}$, and substitution in the equation shows that $A = B = \frac{1}{2}$, and that m is arbitrary. Hence, as Poisson has done, we easily show that $\phi x = \cos x$.

Or thus:—decompose one P and the aggregate on the other P and on its perpendicular: we easily obtain

$$2(\phi y)^2 = 1 + \phi(2y), \quad 2\phi y \phi\left(\frac{\pi}{2} - y\right) = \phi\left(\frac{\pi}{2} - 2y\right).$$

Each of these equations, taken singly, has an infinite number of solutions: taken together, there is no common solution but $\phi y = \cos ay$.

The preceding demonstration does not assume that tendencies are applied at one point, nor even in one right line, but only that they have definite directions in a given plane. If, however, any full definition of tendency demand the idea of a *point of application*, it follows that the line of application of the aggregate passes through the intersection of the lines of application of the aggregants. For if not, $A \times B$ being C , $(-A) \times (-B)$, by 2, would be C' , in a line related to the angle of $-A$ and $-B$ in the same manner as C to the angle of A and B . But C and C' counteract, and application at one point is now essential to counteraction, as well as opposition of direction. Consequently, C and C' are in one line: and there is no one line related similarly to both the angles of A and B , and of $-A$ and $-B$, unless it be a line passing through the point of intersection of the lines of A and B .

2. When different *applications* mean different *points to which one direction is applied*, the aggregate is the algebraical sum of the aggregants, applied at a point in the line of the applications of the aggregants, distant from these points of application inversely as the aggregants, internally or externally, according as the aggregants are in the same or opposite *sides of their common direction*, or, as it might be said, in the same or opposite *subdirections*.

The point of application of the aggregate must be in the line which contains the points of application of the aggregants. For if $A \times B$ be on one side of the line of A and B , then by postulate 2 and a half revolution of the plane about that line, $-A$ and $-B$ have an aggregate $-(A \times B)$ on the other side; whence, by 6, A and B have also an aggregate on the other side, by which 1 is contradicted. The same sort of proof shows that the aggregate must be parallel to the aggregants.

Again, the aggregate of A and B is in magnitude the sum of the aggregants. Let $A \times B$ be C , the *actual distance* of the points of application being c , a *concrete magnitude*. Hence, as proved, $C : A$ depends only on c and $B : A$, and as the *magnitude* c cannot be expressed*

* The celebrated controversy which arose out of Legendre's theory of parallels was conducted (to the best of my remembrance) without any reference to the following point, or at least without any clear use of it. In every case but one, it is impossible to conceive number a function of magnitude: that is, one

concrete magnitude being given, and no other thought of, the actual determination of number cannot follow. There is no number which can necessarily be brought before us as a consequence of the English foot being what it is, without reference to any other length, or the same length repeated. But a number

in terms of the *abstract numbers* $C : A$ and $B : A$, we can have no relation between C, A, B , except in the form $C = A\phi(B : A)$, independently of c . But when $c = 0$, $C = A + B$: therefore this relation always exists. It must be observed that the force of this demonstration depends upon our having introduced $C : A$ and $B : A$, not from any argument upon the necessity of expression by ratios, but from the very postulates themselves.

On the same principles we find that, a, b, c being the distances of the tendencies A, B , and the aggregate C , from a given point in the line of application, the ratio of $c - a$ and $c - b$ is determined by the ratio of A to B . Hence an equation of the form $c = f\left(\frac{A}{B}\right) a + f\left(\frac{B}{A}\right) b$, the unknown function being subject to the condition $f\left(\frac{A}{B}\right) + f\left(\frac{B}{A}\right) = 1$, expressing that when the two tendencies are applied at one point, their aggregate is also applied at that point.

Let any three tendencies P, Q, R be applied in one straight line at the distances x, y, z from a given origin. Aggregate $P + Q$ at the distance $f(P : Q)x + f(Q : P)y$ with R at the distance z : the aggregate $P + Q + R$ is then at the distance

$$f\left(\frac{P+Q}{R}\right) \cdot \left\{ f\left(\frac{P}{Q}\right) \cdot x + f\left(\frac{Q}{P}\right) \cdot y \right\} + f\left(\frac{R}{P+Q}\right) \cdot z.$$

This is not disturbed by going through the same process in a different order of relation: hence the above is identical with

$$f\left(\frac{Q+R}{P}\right) \cdot \left\{ f\left(\frac{Q}{R}\right) \cdot y + f\left(\frac{R}{Q}\right) \cdot z \right\} + f\left(\frac{P}{Q+R}\right) \cdot x.$$

Equate the coefficients of x , write tv and v for $P : R$ and $Q : R$, which gives

$$f\{v(t+1)\} \cdot ft = f\left(\frac{tv}{v+1}\right).$$

Differentiation with respect to v gives, after elimination of ft ,

$$\frac{f'\{v(t+1)\}}{f\{v(t+1)\}} \cdot (1+t) - \frac{f'\left(\frac{tv}{v+1}\right)}{f\left(\frac{tv}{v+1}\right)} \cdot \frac{t}{(v+1)^2} = 0.$$

may be a function of an angle: the very angle itself determines those numbers (ratios of lines) which we call sines and cosines. Imagine a being incapable of conceiving angles in the relations of whole and part: he may, if he can only conceive lines in such relation, be forced to $\frac{1}{2}$, or $\cos 60^\circ$, in its connexion with the angle of an equilateral triangle. Let the difference of angles be to him merely the difference of individuals of a species, as different men or different horses, yet he shall, by measurement, ascertain on right-angled triangles that different angles determine different numbers. Nor shall it be necessary to think of a second angle, for the triangle may be determined by drawing the *shortest distance* from a point in one side to the other. Hence, though an angle be not a number till we settle a

unit to which it may have ratio, yet a function of an angle may be a number. Consequently, if c were an angle, the equation $C = A\phi\left(c, \frac{B}{A}\right)$ does not expel c , for it contains under it $C = A\phi\left(\psi c, \frac{B}{A}\right)$, and ψc may be a number varying with c . If any objection should arise in the case of a second angle implicitly constructed, it may be removed by considering the converse: a *number* determines an angle, without reference to any second angle. Make that number the ratio of the arc to the radius, and the angle is obtainable by means which make no reference, even by tacit consequence, to any other angle.

Multiply both sides by $v \{(1+t)v+1\}$, and the result is expressed by saying that $\frac{f'x}{fx} \cdot x(x+1)$ is the same whether x be $(1+t)v$ or $\frac{tv}{v+1}$. That is, t and v being independent,

$$f'x = \frac{kfx}{x(x+1)}, \quad k \text{ being constant: or } fx = c \left(\frac{x}{x+1} \right)^k.$$

But $fx + f\left(\frac{1}{x}\right) = 1$ for all values of x ; whence $k = 1$, $c = 1$.

Hence
$$f\left(\frac{P}{Q}\right) \cdot x + f\left(\frac{Q}{P}\right) \cdot y = \frac{Px + Qy}{P + Q},$$

whence all the usual forms can be obtained, and the theorem stated at the beginning may be demonstrated.

I now proceed to apply what has been done to the several cases.

1. *Successive translations of a point.* The four postulates are in this case results of thought. The diagonal law is so distinctly selfevident that its deducibility is worthy of note.

2. *Simultaneous translations.* A point cannot undergo two translations at once: it cannot be translated from A to B and also from A to C at one and the same time, B and C being different points. The usual interpretation of what is called simultaneous translation through AB and AC is translation from A to B while the line AB itself is translated, without change of direction, from AB , to CD its equal and parallel. Thus each point of AB is translated through an equal and parallel of AC , while each point in turn receives, as it were, the moving point. The translation of a point, and that of a line, are tendencies which may be aggregated, and the four postulates are intelligible and true of such tendencies considered together. If by translation we merely understand removal from one to another of two parallel lines, the postulates are still true, and simultaneous translation from each side of a parallelogram to its opposite is translation from one to the other of any two parallels which pass through the ends of the diagonal. It is not necessary, in aggregation of translations, that the motion should be rectilinear: translation over AB may be understood as made by motion over any curve line which has A and B for its two ends.

The nearest notion to two linear translations of a point, simultaneously made, is as follows. Let AB and AC both be divided into the same infinitely great number of infinitely small parts, and let translation over the first part of AB be followed by translation over an equal and parallel to the first part of AC ; then the same of the second parts, and so on. If equal subdivisions be made on each line, the diagonal will then be described in a manner which gives a good notion of the *pointed branch* of a curve: and such continuity as a pointed branch possesses may be affirmed of the mode of making the two translations. For any finite part of time, however small, contains its due proportion of the translation parallel to AB , and of that parallel to AC .

3. *Successive and simultaneous rotation about axes passing through a point.* Motion of rotation is brought under the case of tendency having magnitude and direction, by having for its determinants an axis and an angular magnitude. Let two axes remain fixed; and let a point revolve first round one axis and then round the other. All the postulates are satisfied except the third: the result is not indifferent to conversion. But when the angles of rotation are infinitely small this third postulate *is* satisfied, the difference between the results before and after conversion being infinitely small compared with the wholes. And hence demonstration of the diagonal law in composition of successive infinitely small rotations. Of simultaneous rotations, as of simultaneous translations, it must be said that they cannot coexist. But revolution of a point about one axis may be aggregated with revolution of that axis and surrounding spaces about itself or another axis: and in infinitely small rotations the disturbance of the second axis produces an effect which is but an infinitely small part of the whole. It need hardly be stated that, in these cases of translation and rotation, all the postulates are pure results of thought.

Before proceeding further, I must request permission to digress into some remarks on the foundation of geometry. Rectilinear translation and rotation are the two simple elements into which all motions are resolved: the lines in which a point moves by simple translation and by simple rotation, the straight line and the circle, are all which elementary geometry has ever taken into account. The straight line, considered as rotation about a point at an infinite distance, may occur to a mind much accustomed to generalisation as unduly separated from the *other circles*. And Mascheroni, by performing the constructions of geometry with the compasses only, has shown the rejection of the straight line to be as possible as would be the rejection of a circle of any one given radius. But it could have been made out, long before Mascheroni, that such a principle as appears in the rejection of the straight line must be carried further, if acted on at all. For Benedetti (1553) and others had shown that the constructions of geometry require only the straight line and *one circle, of some one given radius*. And this opens reasonable ground of suspicion that all the power of construction which is given by the straight line and circle lies in *any two circles* of different radii, provided one of them be large enough to pass through any two points which can be wanted. As no such limitation of means could be listened to, and as any limitation short of the utmost which leaves sufficient means would be idle, the straight line must be allowed to retain its place, and of course its importance.

The straight line and circle are *self-repeating* curves: any arc of one of them is a *fac-simile* of any equal arc of the same. And they are the only self-repeating *plane* curves. It is then the limiting law of plane geometry to stop after the admission of self-repeating curves, and to allow no others. When we come to solid geometry, we admit the self-repeating surface, the sphere: why do we exclude the self-repeating curve of double curvature, the screw, the most simple aggregate of one translation and one rotation? I believe we have only to answer that Euclid did not do it. If Euclid had possessed that fulness of system in solid which he had in plane geometry, we may strongly suspect that the screw would

have been one of the postulated lines. The difficulties of angular section and quadrature of the circle would never have existed: but until it can be shown that some equally exciting difficulties of construction would have opened into view from the position thus taken, it may be almost affirmed that geometry would not have been the gainer. In the meanwhile, all the struggles to arrive at general angular section and circular quadrature, so far as they were made under Euclid's restrictions, may be described as attempts to combine translation and rotation under the condition that translation and rotation are not to be combined.

4. *Velocity of translation and rotation.* As these are merely, so far as measures are concerned, the translations and rotations themselves defined as made in a given time, nothing additional need be said on the *working meaning* of these terms. But I proceed to ask whether the postulates are results of thought when applied to velocity, without reference to its measure.

Velocity without reference to its measure! Why, what is velocity but a measure? This is sure to be the first question. I answer that if velocity be a measure, it must be a measure of something: of what? If of velocity, then it is no otherwise a measure than as every magnitude is a measure of itself: and the word *measure* is superfluous. But the common sense of mankind, which mathematicians have more than once endeavoured to stifle under a convention, when a psychological difficulty would otherwise have demanded an investigation of its grounds, recognises *swiftness* or *quickness* as a thing *per se*, magnitude in its nature, more or less, not space, not time, not description of space in time, but a notion *accompanying* the description of space in time, and not expressible by anything but of the same kind as itself. Whenever any two magnitudes are continuously changed together, this notion arises: and what we treat under the name of a *differential coefficient* was considered by the mediæval writers, but not numerically, under the name of *intension* or *remission*, according as, in our language, it is positive or negative. If we could suppose a particle of matter to have its changes of rapidity consequent upon its own volition, and poetry bears witness that this is possible in thought, what we call velocity would be the measure of the will to change state. Without going so far, let it only be distinctly conceived that quickness admits of numerical measure somehow, because quicknesses may be conceived under the relation of more and less: let it be conceived that aggregation is possible, that it is independent of all but relative direction, that order of aggregation is of no account, and that, in one and the same direction, quicknesses are aggregated by addition. Suspend for a moment the question whether such abstraction be practicable *to us* without the aid derived from a *measure* of quickness. It follows that the aggregation of velocities of translation and rotation is established prior to the acquisition of a measure.

Now it is to be observed that, in the matter of magnitude, as measurable by magnitude of its own kind, independently of other magnitude, human reason is progressive, in a manner which ought to check that disposition to put psychological thought to sleep which I have adverted to as not uncommon among mathematicians. We are but just arrived at the full notion of the angle, as to be expressed by angles only. When I was a student, works in repute at Cambridge defined the *angle* as *being an arc* to the radius unity. A very modern

treatise on geometry half apologises for considering an angle as a magnitude, and informs the reader that it "may not improperly be considered" as a magnitude. And this at two thousand years from the time when Euclid showed how to take any given angle two, three, four, &c. times, and, which is more to the purpose, established *ratios* of angles. *Belief*, short of certainty or not, is nearly established as a magnitude; *probability*, now fully recognised, begins to be seen to be belief under another name. *Curvature* is as yet hardly recognised, but is on its way: the same may be said of *velocity*, not as a measure, but as a thing measured. *Momentum* and *moment of rotation*, the first of which might more properly be styled *moment of translation*, when compared with the second, are still, in elementary writings, introduced as numerical formulæ derived from the relations of *other things*, and not as *things*. As mind progresses, magnitudes now unconsidered will be gradually received, with the slowness which marks all changes of thought.

5. *Statical pressure*. The effort which would, if unopposed, produce motion, but which by counteraction does not, has had various demonstrations of the law of aggregation proposed, and objections have been offered to every one of them. On the one hand the dynamical proof has been condemned because it introduces into statics the consideration of velocity: on the other hand, many have been puzzled by finding that the thing which, by its very definition, tends to produce motion, is reasoned on, not merely without reference to the idea of motion, but under a compact that any introduction of the idea of motion would be out of place. The statical proofs, as they are called, have failed to establish full confidence in themselves: I suppose the reason to be that they do not clearly enunciate the physical grounds on which they stand: they seem to be *all geometry and no physics*, as if the law of aggregation of pressures were a result of thought. And a result of thought it is declared to be in an excellent manual of physics which I have lately seen. The preceding part of this paper will, it seems to me, establish all or most of these proofs in perfect rigour, as a consequence of definite postulates; it remains to examine here how far these postulates contain results of experience.

Pressure and velocity, two magnitudes derived from different senses, touch and sight, may each be conceived independently of the other. We can imagine, without contradiction, thinking beings who have never seen motion, but have never passed a moment without feeling pressure: we can also, with equal ease, imagine other beings who have constantly seen motion, but have never felt pressure. Our sensations of pressure, and our physical knowledge of it as a cause of motion, institute a connexion between the two which we cannot get rid of, when thinking of ourselves. Our examination of the postulates relative to pressure will require us to put ourselves in the position of beings who want the sense of touch.

(1) Two pressures can aggregate into a third, distinct from either. Is this knowledge wholly a result of thought? That two magnitudes put together make a third is a result of thought in every case in which thought holds the parts and the whole in joint and separate existence at once: as when two lengths AB , BC , make a third length AC . But two pressures in the same direction, and their sum, are not held in joint and separate existence at once: we

neither see parts in the whole, nor feel parts in the whole. We are cognisant of more and less, but not by definite junction: there is no *pressure-point* of union. That aggregation is possible is a result of experience, even as to pressures in one direction. And as to pressures in different directions we may proceed as follows. Imagine a being in a planet where reasoning beings are fixtures, with the sense of sight, but no sense of feeling; and with the notion of cause and effect, as a consequence, much more nearly* that of mere precedent and consequent than with us. We may even suppose it to be pure speculation with him whether any of the motions he has seen were anything but volitions; he imagining, by a bold stretch of analogy, that moving things may change place by will, just as he himself changes subject of thought by will. If it were put to such a being that the motions he sees were in many cases not volitions of the moving body, but effects of a cause, which beings who have a sense not possessed by him call *pressure*, and know otherwise than by its effected motion, and if he were asked to investigate the resulting motion when *two* causes of motion were put in action on the same particle, he might perhaps deliver himself as follows:—"A cause must produce effect, for cause without effect is as inconceivable as effect without cause. As incompatibilities cannot coexist, neither can their causes coexist: for then the effects would also coexist. Now different motions are incompatible: if a particle take one, it does not take the other. Consequently, the notion of the two causes conspiring is absurd. According to your account, these *two pressures*, as you call them—which you say your superior beings in another planet can comprehend by aid of a sense which I do not possess—by merely existing together cease to be themselves, and jointly become something else of the same kind as either. This is incomprehensible." In truth, the whole idea of aggregation of two things producing a third of different properties, in which the aggregants are no longer visible or perceptible, seems due to experience: could thought alone predict such a phenomenon? Even motion itself puts no aggregation in evidence. The aggregation of translations was never distinctly before the thoughts until the controversy about the earth's motion brought it into the field in company with aggregation of momenta.

Granting it known that two pressures must be equivalent to one third pressure, how do we know that there can be but one aggregate? Two pressures are applied at the same moment, all differences, except of magnitude and direction, being excluded by hypothesis. It is also premised that the point of application has no choice and no influence. All we want from experience here is the knowledge that this hypothesis can be realised: the rest follows the notion of causation in its character. To suppose variety of effect possible where every variety of cause has been excluded, is against all the laws under which we inevitably think of causation: these laws it does not concern me to discuss.

(2) The second postulate is clearly due to experience. In geometrical conclusions it is a law of thought that all parts of space have absolutely the same properties: but by experience

* Nothing contributes more to our state of thought about causation than our perceptions of cause and effect, as different things. We know that a thing which we *feel* is the cause of a thing which we *see*: pressure causes motion. The being

whom I suppose in the text would need to derive thought about causation from motion producing motion: and would perhaps hardly arrive at habitual thought about cause and effect.

alone can we know that a system of pressures may undergo translation and rotation without any change in the aggregate. There might have been a fixed direction, a natural polar line of gravitation, such that the action of particle on particle might have been a function of the angle made by their joining line with the polar line, as well as of the distance between them.

(3) The third postulate also depends upon experience. We can imagine, and express if we please, a law of aggregation under which the aggregate should be one thing or another according as the aggregants enter in ascending or descending order of magnitude. And we can imagine the law of nature being expressed by one of these to the exclusion of the other.

(4) The fourth postulate seems at first sight to be purely a result of thought: the whole is made up of all the parts; the weight of the whole is equal to the sum of the weights of all the parts. Nor can it be denied that if the pressures were wholly unconnected, so that each of them acts in the same way whether the others be more or less, present or absent, this postulate would then be a result of thought. But this is only saying that if pressures be assumed to act jointly by aggregation, the postulate which the notion of aggregation demands must be conceded. For, as noted at the beginning of this paper, the distinction between junction by aggregation and other junctions, is that the effect produced by each aggregant is wholly unaffected by the magnitude of the others. Granting this, we cannot dissociate our right to express a magnitude by *seven* from our right to say it is made up of *four* and *three*. But it is conceivable that one pressure may receive modification from the mere presence of others: and it is often actually the case. If weights be hung one under another on the same string, each weight abstracts weight from those under it, and adds weight to those above it. The equality of action and reaction silently makes good the position in which the speculator may imagine he can call thought to witness that the weight of the whole *must* be equal to the sum of the weights of the parts. That pressures combine by *aggregation*, and not by *composition*, can be known only by experience.

It thus appears that the proofs of the *parallelogram of forces*, as it is called, are not those mathematical playthings which they have seemed to be when the character of the fundamental assumptions is left to be decided by first appearances. There is not one of the four postulates which might not be imagined false in objective nature, though all are true of notions of space and time. That these postulates are so simple, so fit for the work which is to be done, that they seem necessary until close consideration is applied, may only be a consequence of our familiarity with their action and with their results. It may be they are evidently what they ought to be only as it was evident to Dr Moore's travelling servant that blue is the proper colour for the artillery. The unfeeling and immoveable rational being to whom I have appealed above might perhaps arrive at other conclusions, if he were consulted *à priori*. For instance, he might doubt whether simplicity ought to characterise laws which have very complicated work to do.

When I say that the diagonal law of aggregation is thus founded upon results of experience, I mean it in the sense in which it is always said that the law of gravitation is founded on experience. The observed ellipse was the first proof of the law: not the law of the ellipse.

The four postulates give the diagonal law: but the diagonal law gives the four postulates; grant the law, and the postulates all follow. Actual experiment, then, should be applied to the finished law: which would be proved with far greater ease than the indifference to order of successive aggregations.

6. *Dynamical pressure.* A misuse of terms prevails in this part of the subject. Writers distinguish two kinds of force; *accelerating* force and *moving* force. Accelerating force, which any one would suppose to be the force which accelerates, is no such thing: it is the effect produced, the very acceleration itself. I dwell upon this in memory of the confusion which it created in my own mind when I was a student. The symbol $\frac{d^2x}{dt^2}$ is a purely mathematical notion: and it means the acceleration which the velocity of x is receiving at the end of the time t . This acceleration depends upon the pressure applied at the particle directly and the mass of the particle inversely: but it is made to take its name from one only of the two determinants. It is as if a man were held to be one speaking man or another, according as he made one speech or another. The confusion may have arisen in this way. Just as in statics we are held to exclude the idea of motion, so in dynamics we are held to exclude the idea of equilibrium, and of forces as equilibrating. Accordingly, supposing ourselves only to know force by motion produced, we make motion produced a measure of the force. In so doing we are simply wrong: the *momentum* produced is a measure of the force. By substituting the simple term *acceleration* for accelerating force, we gain truth and clearness at one step.

Again, the so called *moving force*, designated by $m \frac{d^2x}{dt^2}$, represents the pressure which produces acceleration: or only differs from it by our choice of units. Let the pressure be measured by that unit which, applied to a unit of mass, creates a unit of velocity in a unit of time, and the above expression represents the number of units of pressure. In writings on dynamics, the moving force is a mysterious effect of the pressure which is not the pressure, but *as* the pressure. If momentum were more definitely introduced, and as a magnitude *per se*, instead of a convenient name for a formula, the *rate of alteration* in momentum would claim its name and introduction; and the dependence of this rate on the pressure applied would be a great law of mechanics. But as the matter often stands, the rate at which momentum varies is not introduced in connexion with momentum, and momentum itself is not presented as a *real thing*, but as a product of two symbols. The differential coefficient of momentum, detached from its primitive function, is presented under a name which just confounds it with its cause, without deducing it from its cause.

One of the principles in operation in the preceding confusion is this, that causes are in quantity as their effects. The celebrated disputes about the measure of force have arisen in great part from this assumption, which holds good only so long as we know nothing about the cause except its effect. In this case, cause is but another name for the effect, for every purpose of calculation, and for every purpose of thought, except the craving for the idea of cause,

which is a part of our temperament. This principle would justify our declaring, as a result of thought, that in the same or equal masses, accelerations are as the pressures which produce them. Now here we know and measure pressure by means totally different from those by which we know and measure acceleration. We find that pressures are as the produced accelerations: but we can think of them as under other laws.

Should the pressures not be as the velocities produced in given times, one of two results of physics is false: either the fourth postulate is not true of pressures, or the velocity due to the aggregate is not the aggregate of the velocities due to the aggregants. If v and w be two velocities due to two pressures ϕv and ϕw , in the same direction, and if $\phi(v+w)$ be the pressure due to the aggregate velocity, then if $\phi v + \phi w$ be the aggregate pressure, and $v+w$ its velocity, we have $\phi v + \phi w = \phi(v+w)$, which gives $\phi v = cv$, if v and w be wholly unrelated to each other. That pressures are as velocities produced, important and fertile as the principle may be, is not a fundamental law in our order of thought. Dismissing the pure result of thought that velocities are aggregated by addition, the connexion of pressure and velocity depends on, and is a mathematical consequence of, two more simple laws. First, that pressures producing motion in one direction are aggregated by addition: secondly, that the velocity due to the aggregate is the aggregate of the velocities due to the aggregants. The question now is, do these two laws, when the first three postulates are introduced, show any dependence in thought each on the other.

The first of these two laws, which is in fact the fourth postulate, joined with the other three, gives the diagonal law of aggregation to pressures producing motion: that is, the pressures are aggregated by the same law as the velocities. But this deduction, extending as it does to all combinations of direction, does not advance us one step towards the conclusion that the velocity due to the aggregate of pressures is the aggregate of the velocities due to the separate pressures: the diagonal pressure does not necessarily produce the diagonal velocity. If ϕv be the pressure which produces in a given time the velocity v , then v and w , imparted at an angle θ , give $\sqrt{(v^2 + w^2 + 2vw \cos \theta)}$ in the diagonal: while ϕv and ϕw produce the pressure $\sqrt{\{(\phi v)^2 + (\phi w)^2 + 2\phi v \cdot \phi w \cdot \cos \theta\}}$ in the diagonal. The equation

$$\phi \{ \sqrt{(v^2 + w^2 + 2vw \cos \theta)} \} = \sqrt{\{(\phi v)^2 + (\phi w)^2 + 2\phi v \cdot \phi w \cdot \cos \theta\}}$$

may not be satisfied: nor can we deduce it from any simple law in addition to those given, except $\phi v + \phi w = \phi(v+w)$.

Laplace (*Méc. Céle.* l. i. c. 6) discussed the effect which would be produced upon the equations of motion by the assumption of ϕv left indeterminate. In this discussion, however, he assumed the diagonal law of aggregation of pressures producing motion: for his aggregants of ϕv are $\phi v \frac{dx}{ds}$, &c. This was but a partial inroad into the region of *physical impossibility*: he ought to have left the law of aggregation of pressures as open as the law of connexion of pressures and velocities; but all his unnatural conduct consisted of dispensing with the principle that the sum of the causes is the cause of the sum.

7. When by application we mean application in a given direction at a point, our cases are aggregation of rotation about parallel axes, and aggregation of parallel forces. On these there is no occasion to speak fully; the first is entirely a result of thought; the second rests on postulates shown to contain experience in precisely the same manner as in the case of pressures variously applied at one point. Neither will it be necessary to lengthen this paper by treating separately of moment of rotation.

The preceding investigations show that no complete or *double* algebra can exist, in which $A + B$ is anything but the diagonal of A and B , provided that the rules of the incomplete algebra are to be preserved unaltered.

A. DE MORGAN.

UNIVERSITY COLLEGE, LONDON,
February 10, 1859.

IV. *On Plato's Cosmical System as exhibited in the Tenth Book of "The Republic."* By J. W. DONALDSON, D.D. *Trinity College; Vice-President of the Society.*

[Read Feb. 28, 1859.]

NEARLY sixteen years ago I communicated to the Philological Society of London an explanation of the passage in the 8th book of Plato's *Republic*, which contains the description of his mysterious Number. It did not form part of my task on that occasion to interpret another passage in the same dialogue, which is scarcely less difficult and which is not unconnected with the results of that arithmetical enigma, I mean the view of the cosmical system combined with the destiny of man, which is found in the 10th book, and is there given as part of the *Divina Commedia* put into the mouth of Er the Pamphylian. As, however, nothing has been done since 1843 to clear up the obscurities of this passage, and as it involves considerations of no little interest and importance, I will take this opportunity of communicating my opinions respecting it to a Society, which is not only prepared to listen to philological discussions, but is also, in name and reality, devoted to the study of philosophy in all its applications.

For the sake of distinctness, I propose to divide my disquisition into the following heads. (1) I will give a translation of the passage in question, as I think it ought to be rendered. (2) I will make some philological remarks on the Greek text. (3) I will endeavour to indicate Plato's object in giving this fanciful picture of the universe. (4) I will attempt to trace the origin of his speculations.

(1) The Pamphylian Dante, after describing the torments of the wicked in a future state, proceeds to describe the experiences of the righteous as follows (*Plat. Resp. x. p. 616 B*): "When in each case these spirits had passed seven days in the meadow, they were obliged to leave the place on the eighth day, and to travel, till they arrived, on the fourth day of their journey, at a place from whence they looked down from above on a straight line of light, like a pillar, stretched throughout the whole of heaven and earth, most of all resembling the rainbow, but brighter and purer still. At the middle point of this column of light the spirits arrived after a day's journey, and there saw the extremities of the girding bands of heaven stretching from heaven to this axis. For this axis of light is the bond of heaven, and holds together all the revolving spheres, just like the hawser, which is passed round the hull of a trireme. But from the extremities again is suspended the spindle of Necessity, by means of which all the

revolutions of the spheres are kept up. The shaft and hook of this spindle are of steel, but the ring or wheel is compounded of this and other metals. The nature of the ring is as follows. In shape it is like those which are used to balance and twirl the ordinary spindle; but, according to the Pamphylian's description, we must conceive it, as though in a large, hollow ring, scooped out in the middle, another similar ring were inserted, so as to fit it exactly, like the boxes which are made to fit into one another. In the same way, a third and fourth and then four others are inserted. For there are in all eight hoops inserted into one another, showing their rims on the upper surface like so many circles, and making one continuous surface of a broad ring around the shaft of the spindle, which is driven right through the middle of the eighth hoop. The first and outermost hoop has the circle of its rim broadest; the sixth from the outside has the next broadest rim; in the third place comes that of the fourth; in the fourth place that of the eighth; in the fifth that of the seventh; in the sixth that of the fifth; in the seventh that of the third; and in the eighth place that of the second (which is therefore the narrowest rim). Then again the rim of the greatest circle is spangled with points of light; that of the seventh is the most brilliant; that of the eighth has its colour from that of the seventh reflected on it; that of the second and that of the fifth are similar, but yellower than the former; that of the third has the whitest colour; the fourth is rather red; and the sixth exceeds the second in whiteness. Now the spindle as a whole revolves in the same direction, but, while the whole is revolving, the seven included rings perform the circuit slowly in a direction opposite to that of the whole; and of these the eighth travels quickest, then the seventh, sixth, and fifth, which rotate uniformly; the third in point of velocity, as it appeared to Er and his companions, was the fourth ring; the fourth in speed was the third, and the slowest was the second. The spindle itself spins round on the knees of Necessity. And on each of the circles, on the upper side of the ring, there stands a Siren, carried round with the rotation, and uttering each one note according to the scale, so that from all the eight there results a single harmony. At equal distances all round the ring are seated three other female forms, each on a throne; these are the daughters of Necessity, the Destinies—Lachesis, Clotho, and Atropos; and they, arrayed in white vestments and wearing crowns on their heads, chant to the harmony of the Sirens, Lachesis the past, Clotho the present, and Atropos the future. And Clotho with her right hand from time to time takes hold of the outer circle of the spindle and twirls it altogether, and Atropos with her left hand turns the inner circle in like manner; whereas Lachesis now with her right hand, and now with her left, twirls the outermost and the inner hoops alternately. The souls, as soon as they arrived, were obliged to go forthwith to Lachesis. An interpreter first marshalled them in order, and then, taking from the lap of Lachesis a number of lots and patterns of lives, mounted a lofty pulpit, and spoke as follows: 'Thus saith the virgin Lachesis, the daughter of Necessity. Souls, whose life endureth but for a day, behold the beginning of another period of the mortal race, that will end in death! Your fate shall not choose you by lot, but you shall choose your fate. Let him, who draws the first lot, choose for himself a life, which shall of necessity abide with him. Virtue hath no master: every one that honoureth her shall have more of her; and he who slights her shall have less of her. The blame rests with the chooser. God is blameless!'

Such is, as I believe, the correct translation of this astronomical apologue, which seems to me to exhibit its fanciful details in a very vivid and intelligible picture.

(2) I now proceed to examine those points in the Greek text which have been misunderstood by some or all of the previous commentators on Plato or by the translators of this passage.

A great deal of difficulty has been occasioned by the words: ὅθεν καθορᾶν ἄνωθεν διὰ παντός τοῦ οὐρανοῦ τεταμένον φῶς εὐθύ, οἶον κίονα. Böckh supposes (*De Platon. System. Cælest. Globor.* p. vi) that this column of light is the Milky-way. Schleiermacher, who regards this view as most probably correct (*Uebersetz.* p. 621), is in doubt whether the phrase οἶον κίονα is to be understood in the literal sense, or as denoting the appearance from without of a band of light connecting the equator with the pole. The English translators of the *Republic*, Messrs. Davies and Vaughan, by rendering the words "a straight pillar of light stretching across the whole heaven and earth," convey no intelligible sense. The Greek says: διὰ παντός τοῦ οὐρανοῦ τεταμένον, and this can only mean that the column of light went *through* (not *across*) the heaven; in other words, it implies that the column was the axis of the heavenly sphere. Similarly in the *Tim.* p. 40 B, we have: γῆν ἰλλομένην περι τὸν διὰ παντός πόλον τεταμένον. And Sophocles uses τέταται of light beaming down in a straight line (*Philoct.* 820, *Antig.* 600). That the rainbow was regarded by the ancients as an arch, in accordance with its name (*New Crat.* § 464, note), has nothing to do with this question; for the comparison with the rainbow here is only in respect of its brightness, as appears from the epithets λαμπρότερον καὶ καθαρώτερον.

The next difficulty is created by the words: καὶ ἰδεῖν αὐτόθι κατὰ μέσον τὸ φῶς ἐκ τοῦ οὐρανοῦ τὰ ἄκρα αὐτοῦ τῶν δεσμῶν τεταμένα. For this, Schleiermacher, who is followed by Stallbaum, would read τὰ ἄκρα αὐτοῦ ἐκ τῶν δεσμῶν τεταμένα. It appears to me that this alteration is not only needless, but that it destroys all the meaning of the passage. The spirits are supposed to be travelling down the column of light: for they arrive ὅθεν καθορᾶν ἄνωθεν, and they continue their progress until they get to the middle of it, i. e. to the center of the sphere, where they see (of course both above and below them) the ends of the girding bands of heaven, like meridian lines, reaching from all the heavenly vault and fastened to the two poles of the central column of light. And here τεταμένα is illustrated by the use of συντανύω in Pind. *Pyth.* I. 87: πολλῶν πείρατα συντανύσαις ἐν βραχεῖ: for πείρατα means "ropes" (see Hom. *Il.* XIII. 359, XI. 336; *New Crat.* p. 294 (325, 3rd edit.)). It is scarcely necessary to remark that Plato, like the other ancient writers on astronomy, regarded the heavenly sphere as a firmament or στερέωμα, more or less solid, which these bonds would contribute to strengthen.

That there might be no doubt as to his meaning, Plato adds a significant comparison: εἶναι γὰρ τοῦτο τὸ φῶς ξύνδεσμον τοῦ οὐρανοῦ, οἶον τὰ ὑπόζώματα τῶν τριήρων, οὕτω πᾶσαν ξυνέχον τὴν περιφορὰν. But it is an astonishing fact that the commentators have been quite unable to avail themselves of the explanation conveyed by this reference. Some, misled by a scholion on Aristophanes (*Equites*, 279), identify the ὑπόζώματα with the ζυγά of the trireme, and Liddell and Scott define ὑπόζωμα as "the rowers' bench which runs across the ship's

sides." That the ὑποζώματα were ropes is implied by Plato himself (*Leges*, p. 945 c), and this is distinctly stated by Hesychius, who says (s. v. ζωμέματα): ὑποζώματα, σχοινία κατὰ μέσσην τὴν ναῦν δεσμευόμενα. In the inscriptions published by Böckh (*Seewesen*, No. XIV. c. 105), the ὑποζώματα are classed among the κρεμαστά σκεύη and are opposed to the ξυλινά. And Apollonius Rhodius (*Argon.* i. 368) describes the process thus: ἔζωσαν πάμπρωτον ὕστρεφεῖ ἐνδοθεν ὄπλῳ τεινόμενοι ἐκάτερθεν. But even Schneider, who is acquainted with these passages, understands a rope passing from stem to stern (*Germ. Transl. of the Republic*, p. 316). He is led to this by the description of the column of light stretching right through the heaven and earth. But the old commentator on this passage, quoted by Suidas (p. 3529 c, Gaisford), saw the truth; he says: τεταμένον φῶς εὐθὺ οἶον κίονα: τὸ οὐράνιον λέγει τὸ γὰρ συνεχές τὴν ὑποφοράν, τὸ ὑπόζωσμα τοῦ κόσμου. The fact is, that when a vessel went to sea, she had a number of these ὑποζώματα passed under her, very often two or more fastened together in a common knot, from which hung a loose rope, intended to be drawn tight across the ship, whenever the emergency occurred. In one of the inscriptions (No. ix. l. 26) we read of a ship in dock: αὐτὴ ὑπέζωται. And in the *Acts of the Apostles* (xxvii. 17) we read: βοθηταῖαι ἔχρωντο, ὑποζωννύντες τὸ πλοῖον, which implies that the tackle was ready at hand and had only to be used. Strictly it seems that διαζώννυμι indicated the process of fastening the ends of the ὑποζώματα across the ship (Appian, *B. C.* v. 91). But the whole of the tackle was called ὑπόζωμα, and ὑποζώννυμι denoted the whole operation. The name *mitra* given to the ὑπόζωμα by Isidore (xix. 4, 6): *mitra, funis, quo navis media vincitur*, exactly expresses the loose hanging ends of the ties (*redimicula*) before they were fastened. And there cannot be any doubt that Plato regarded the central column of light as the ends of this *mitra* fastened in the middle and so pulling taut all the girding bands which passed round the solid sphere of the universe—the only difference being that in the sphere the fastening came from all sides, in the trireme only from below. After this explanation, it is quite unnecessary to criticise the supposition of C. E. C. Schneider, in his edition of the *Republic*, that the bands of the universe are described by Plato as fastened to the centre of the axis.

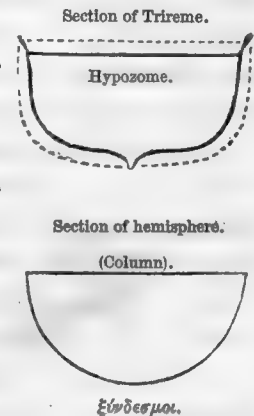

The next difficulty in the Greek is occasioned by the description of the spindle of Necessity. The words are: ἐκ δὲ τῶν ἄκρων τεταμένον Ἀνάγκης ἄτρακτον, δι' οὗ πάσας ἐπιστρέφεται τὰς περιφοράς· οὗ τὴν μὲν ἠλακάτην τε καὶ τὸ ἄγκιστρον εἶναι ἐξ ἀδάμαντος, τὸν δὲ σφόνδυλον μικτὸν ἐκ τε τούτου καὶ ἄλλων γενῶν. That the word ἄτρακτος signifies "a spindle," and not, as the English translators most absurdly render it, "a distaff," is a well-known fact, and the whole context shows that the reference is to the spindle with its rotatory motion, and not to the distaff, which was thrust into the ball of flax or wool, and held firmly in the left hand of the spinner, or, as we see in an ancient Mosaic at Rome, fixed in the girdle¹. Nothing can be simpler than the process of spinning among the ancients, and no person pre-

¹ Sir J. G. Wilkinson also confuses between the distaff and the spindle in his *Ancient Egyptians*, III. p. 136. Some of the figures which he gives as spindles are distaffs.

tending to be a scholar ought to be unacquainted with the brief but lucid description of the use of the *colus* and *fusus* in the "Peleus and Thetis" of Catullus, LXII. [LXIV], 311—317:

Læva colum molli lana retinebat amictum;
Dextera tum leviter deducens fila supinis
Formabat digitis: tum prono in pollice torquens
Libratum tereti versabat turbine fusum:
Atque ita decerpens æquabat semper opus dens,
Lanaeque aridulis hærebant morsa labellis.

Although the passage before us refers, like Catullus, to the three *Parcæ*, there is no express mention of spinning, unless we may presume that the Fates spin threads of light from the girders of the sphere. Clotho, Lachesis and Atropos merely turn the wheel of the spindle, and the ἄγκιστρον, the *dens* of Catullus, that is the hook or tooth, in which the thread was fixed so that its prolongation by the process of spinning allowed the spindle to descend till it touched the ground, is in Plato's description merely the fastening, the κρατεροὶ ἀδάμαντος ἄλοι, as Pindar says (*Pyth.* iv. 71, cf. 234, and *Æsch. Ag.* 211), which belong to the idea of ἀνάγκη, and of course the spindle of Necessity is not supposed to descend by a lengthening thread. The only apparent difficulty in the Greek of the passage is that the word ἡλακάτη, which generally means the distaff, is here used to denote the shaft of the spindle. It is a well-known fact, however, that while ἄτρακτος is used to designate "an arrow," ἡλακάτη may signify any long tapering shaft, such as the top-mast of a ship (*Athen.* 475 A), the shafts of reeds between the knots (*Theophrastus, Hist. Plant.* ii. 2, § 1), or a reed generally, (*Hesychius: ἡλακάτη=δόναξ*), whence *Æschylus* spoke (*Æsch. Fr. ap. Schol. Hom.* p. 448) of ποταμοὶ πολυηλάκατοι or "rivers with reedy banks." Although therefore the specific use of ἡλακάτη and of the neuter plural ἡλάκατα, and the etymology of these words, according to *Buttmann's* instructive analysis (*über das Elektron, Mytholog.* ii. pp. 337 sqq. translated in my notes on the *Antigone*, pp. 213 sqq.), refer to the distaff on which the wool or flax was fixed for spinning, there was nothing to prevent Plato, who had no occasion to mention that part of the spinning apparatus; from using the word ἡλακάτη to denote the long axis of his imaginary spindle, which regulated the movement of the heavenly bodies.

The description of the wheel or ring has been misunderstood by more than one commentator. The Greek words are: κύκλους ἄνωθεν τὰ χεῖλη φαίνοντας, νῶτον συνεχές ἐνὸς σφονδύλου ἀπεργαζομένους περὶ τὴν ἡλακάτην. These words can have no meaning except that which I have given to them. For κύκλους must be a secondary predicate, and the νῶτον συνεχές, like the νῶτον θαλάσσης, must denote a horizontal surface, unless something is specifically stated to the contrary. Besides, the wheel of the ancient spindle is known to have had a horizontal surface on the upper side, and it was always at the lower end of the spindle, something like a teetotum with a long shaft. In spite of this, *Schleiermacher*, and, after him, *Cousin*, understand the wheel as a spherical or globular body about the middle of the spindle. We shall see that this could not have been what Plato intended. The rims represent the surfaces traversed by the different Sirens, and while each planet imparts its colour to the path of its rotation, the outer region, or that of the fixed stars, is said



to be *ποικίλος*, that is, spangled, or, as Shakspeare expresses it, in the passage which will be quoted by and bye, "thick inlaid with patines of bright gold;" and in another passage (*Hamlet*, Act II. Sc. 2), "fretted with golden fires." The translators miss the force of the epithet when they render it by *bunt*, or "exhibiting a variety of colours," for *ποικίλος*, as distinguished from *αίολος*, which denotes stripes or bands of alternate colours, always implies variation by way of spots—*distinctus maculis*—and the epithet *ποικιλάνιος* (Pind *Pyth.* II. 8) is explained by the *χρυσόνωτος ἡνία* of Sophocles (*Aj.* 847), i. e. the rim adorned on the upper side with little patines or plates of gold (see Lobeck's note on the passage).

The only other remark which I have to make on the Greek text is that in 617 B. I prefer the common reading *ανάτονον*, or *ἀνά τόνον*, which is found in many of the MSS. and is approved by Wyttenbach (*ad Plut. de anim. procreat.* p. 189), to the reading *ένα τόνον*, which most of the modern editors have adopted on very good authority, but which appears to me unintelligible. Plato obviously says that each of the Sirens uttered one note according to the scale, that is, as Cicero expresses it (*Somn. Scip.* c. 5): *illi octo cursus septem efficiunt distinctos intervallis sonos, qui numerus rerum omnium fere nodus est.*

(3) The next step is to indicate the philosopher's object in giving this fanciful picture of the universe.

It appears to me that here, as at the beginning of the eighth book, Plato's design was to give due prominence to the mysterious properties of the sacred numbers¹. In common with the Pythagoreans he laid much stress on the numerical coincidences between the results of astronomy and music as they were then known. And an additional coincidence had been furnished by the moral and political theory propounded in the *Republic*. At every turn he was met by the sacred number *seven* and its constituent parts. If he began with geometry, he had the *γαμήλιον διάγραμμα* (Plut. *Is. et Os.* p. 373 E), or the right-angled triangle with the commensurable sides 3, 4, 5, and as $3^2 + 4^2 = 5^2$, so $3^3 + 4^3 + 5^3 = 6^3$. Then *six* again, the number of sides in the cube, is the first perfect number. And when he passed on to music he found that the number 6, as the combination of the first odd and even, played a prominent part in the theory of harmonics. It was called *Ἀφροδίτη*, from the goddess of love, who was the mother of Harmonia. And while the two ratios with which the Greeks were best acquainted in their musical scale were $\frac{4}{3}$ and $\frac{3}{2}$, representing the 4th and 5th, which, when multiplied together, gave the number 2 as the representative of their *diapason*, so the cube itself implied all the harmonic numbers, for it consists of 12 sides, 8 angles and 6 planes, and these numbers stand related to one another in harmonic proportion. Passing on to cosmogony he recognised the same numerical harmonies in the order of the universe. The system of the heavenly bodies was represented by the intervals of the musical scale according to the Platonic *tetractys*, as it is called, which branches from unity on one side by three successive doublings, and on the other by three successive treblings: thus 1, 2, 4, 8, and 1, 3, 9, 27,—the product of the last terms, which are the cubes of 2 and 3, being equal to the cube of 6, or the sum of the cubes of

¹ All the learning on this subject was collected by Cornelius Agrippa in his second book *De Occulta Philosophia*, chaps. III—XII.

3, 4, and 5, and thus being the psychogonic cube, as Anatolius calls it (*Theolog. Anthon.* p. 40, ed. Ast.), because it is the period of the Pythagorean metempsychosis. On the other hand, there are 7 terms in the double tetractys, and the sum of the first six is represented by the seventh: for $1 + 2 + 3 + 4 + 8 + 9 = 27$. Lastly, if we take the mean proportionals between 8 and 27, namely, 12 and 18, we get the musical ratio $\frac{2}{3}$. And as the other musical ratio $\frac{4}{3}$ represents the sides including the right angle in the sacred triangle, and these added together make the sacred number 7, so the other sacred number 5 may be resolved into the constituent parts 2 and 3, and the numbers 7 and 5 when added together make another regulative number of mysterious import, the number of months in the year. In his moral and political speculations Plato was met by the same numbers. There were 4 cardinal virtues, 3 parts of the human soul, and 5 forms of government; and I have shown elsewhere that, in the *Republic* (p. 546), the mystical period of the state is defined by an elaborate calculation, which amounts to the equation $\frac{4^3}{3^3} \cdot 5^3 = \frac{2^3}{3^3} \cdot 10^3$, all these being musical



and Pythagorean numbers, and being cubed according to the theory of harmonic completeness, just as in p. 587 c, the number 729, i. e. 9^3 , represents the misery of the tyrant, because he is nine times as wretched as the oligarch. The number 7 reappears in the *Laws* (v. p. 737), where Plato limits his citizens to 5040, ἀριθμῶ τῶνος ἕνεκα προσήκοντος, i. e. because this is the continued product of the first seven digits.

Applying these considerations to the passage before us, we see at once the reason for the seven days spent in the meadow, and the five days occupied on the journey to the center of light. The eight hoops of the wheel are of course the regions belonging to the seven planets and the fixed stars. And the order of the planets is that which is given in the *Timæus* (p. 38), where, as here, the positions of Venus and Mercury are interchanged. For the order of the eight concentric hoops, beginning with the outermost, is as follows: 1st the fixed stars, 2nd Saturn, 3rd Jupiter, 4th Mars, 5th Mercury, 6th Venus, 7th the Sun, 8th the Moon; the Earth being the axis of the system. The colours of the planets themselves are supposed to be communicated by their motion to the orbits which they traverse. The different widths of the hoops indicate the different inclinations of the orbits to the plane of the ecliptic. But the intervals intended are regulated by the successive terms of the double tetractys (*Timæus*, p. 36 B); thus:

Moon.	Sun.	Venus.	Mercury.	Mars.	Jupiter.	Saturn.
D	☉	♀	☿	♂	♃	♄
1	2	3	4	8	9	27

The introduction of the Sirens, as diminutive figures small enough to stand on the separate hoops of the wheel, is sanctioned by the plastic art of the Greeks in Plato's time. The great statue of Juno in the Heræum at Argos, which was set up by Polycleitus towards the end of the Peloponnesian war, had a crown adorned with sculptured figures of the Horæ

and Charites (Pausan. II. 17, § 4). And the more ancient statue of the same goddess, set up at Coroneia in Bœotia by Pythodorus, represented Juno as holding statuettes of the Sirens in one of her hands (φέρει δὲ ἐπὶ τῇ χειρὶ Σειρῆνας, Pausan. IX. 34, § 3). That they represent the music of the spheres is sufficiently obvious, and this presumed music, which is a result of the numerical coincidences already discussed, is represented as the vocal utterances of a concert of heavenly beings, in accordance with a personification found in the poetry of all ages. In the book of *Job* we read (xxxviii. 7) that "the morning-stars sang together, and all the sons of God shouted for joy." And Shakspeare in a passage, to which I have already referred, and which Mr Hallam has quoted (*Lit. of Europe*, III. p. 147) as illustrating Campanella's theory of the sensibility of all created beings, has distinctly, in this as in other passages, given us an echo of the words of Plato (*Merchant of Venice*, Act v. Sc. 1):

"There's not the smallest orb, that thou behold'st,
But in his motion like an angel sings,
Still quiring to the young-ey'd cherubims:
Such harmony is in immortal souls;
But, whilst this muddy vesture of decay
Doth grossly close us in, we cannot hear it."

Milton has imitated this in his *Arcades*, where he distinctly alludes to the words of Plato¹:

"But else in deep of night, when drowsiness
Hath lock'd up mortal sight, then listen I
To the celestial Sirens' harmony,
That sit upon the nine infolded spheres,
And sing to those that hold the vital shears,
And turn the adamantine spindle round,
On which the fate of gods and men is wound.
Such sweet compulsion doth in music lie,
To lull the daughters of Necessity,
And keep unsteady nature to her law,
And the low world in measur'd motion draw
After the heav'nly tune, which none can hear
Of human mould with gross unpurged ear."

We should have expected perhaps that the personification in the passage before us would have given us *Muses* instead of *Sirens*. And Plutarch seems to suppose that Plato really meant the *Muses*. In one passage (*Sympos.* IX. 14, p. 1082, Wytttenb.) he says that Plato seems to him ἐξηλλαγμένως ἐνταῦθα καὶ τὰς Μούσας Σειρῆνας ὀνομάζειν, "contrary to usage to have here named the *Muses* *Sirens*." And in another passage (*de Animæ Procreatione*, 32, p. 190, Wytttenb.) he says that by the eight *Sirens* Plato meant the eight *Muses*, who dealt with heavenly things, it being the province of the ninth to compose by her strains the anomalies and disturbances of this lower world. It seems to me that Plato preferred the *Sirens* to the *Muses* for an etymological reason of his own. In the *Theætetus* (p. 153 c, d) he had referred to the line of Homer (*Il.* IX. 17): σειρῆν χρυσεῖνν ἐξ οὐρανóθεν κρεμάσαντες, as denoting the Sun which binds all things together. And as the *Sirens* represent the eight strings of the

¹ See also his paper *De Sphærarum Conoentu*, *Prose Works*, p. 846.

octachord, which, according to the Pythagoreans, represented the eight spheres of heaven, and, according to Heraclitus, exhibited the harmony of perpetual motion, on which the world's existence depends, it is most reasonable to conclude that in this, as in so many other instances, Plato had recourse to etymology; and certainly his derivation of *σειρήν* from *σειρά* is not one of his least successful efforts.

It is not part of my plan on the present occasion to enter into any discussion respecting the doctrine of Metempsychosis as indicated in this passage, or the choice of life which is given to the soul on the commencement of a new period of existence. It is to be remarked, however, that while Clotho, the destiny of the present, turns the orbit of the fixed stars, Atropos, the destiny of the future, turns the planetary orbits; but Lachesis, the destiny of the past, sometimes contributes to the one motion, and sometimes to the other. This seems to me to indicate much the same doctrine as that which is implied in the statement that the lots and patterns of lives lie in the lap of Lachesis only—namely, that the present and the future are but repetitions of the past—a doctrine of which Giambattista Vico has made such an elaborate development in his *Scienza Nuova*. "Every living creature," says Schleiermacher (*Uebersetzung*, p. 624), "obtains its lot originally from the lap of the past. Every soul, which is born, must have lived already, not only because the number of souls is not augmented, but also because the different forms of human life must remain essentially the same on account of that harmony of history with the regular and periodic return of the heavenly motions; only each soul is at liberty to choose its next career from a number, now greater, now less, of lives offered to its choice."

(4) I now pass on to the last, and not least interesting, of the questions, which I have proposed to investigate—where did Plato find the materials for this cosmical romance? He tells us himself that it is not a long tale, like that which Ulysses narrated to Alcinous, but that it is really due to a brave man, Er the son of Armenius, a Pamphylian (p. 614 B). He might, of course, have invented these names. But this is not his practice. And I believe I shall be able to show that, besides the Pythagorean elements in this cosmical description, it is professedly borrowed from the speculations of Zoroaster, as they were adopted and set forth by Heraclitus of Ephesus.

In the first place, there is a distinct tradition to this effect. Clement of Alexandria says (*Strom.* v. pp. 710, 711 Potter): "Plato has mentioned, in the 10th book of his *Republic*, a certain Er the son of Armenius, by race a Pamphylian, who is Zoroaster. At all events Zoroaster himself says: 'Thus wrote Zoroaster the son of Armenius, by race a Pamphylian: having fallen in battle and gone to Hades, I learned these things from the gods.'" And this passage is repeated by Eusebius (*Præparatio Evangelica*, XIII. 13, p. 266, Heinichen). Taken by itself this tradition is of little value, for it was the well-known practice of these later writers to refer the philosophy of the Greeks in general and of Plato in particular to an Oriental source, and the passage quoted from Zoroaster might be from some forgery, of which Plato's apologue was the basis. If, however, we go more deeply into the subject, if, on the one hand, we examine the doctrines attributed to Heraclitus and their connexion with the religious system of the ancient Persians, of which Zoroaster was the remodeller, and if, on the other hand, we consider

how far Plato was likely to have become acquainted with both, and what traces there are in the narrative before us of the speculations of the Iono-Persian mytho-philosophy, we shall come, I think, to the conclusion that in this case at least there was a foundation on fact for the tradition which Clement has reported to us.

That Plato had become acquainted with the doctrines of Heraclitus from his earliest days is as well known as any fact in the history of philosophy (Aristot. *Metaph.* i. 6); there is a distinct tradition that he had been in Caria (Plutarch, *De Dæm. Socr.* p. 579 B), and it has been conjectured from a passage in the *Theætetus* (p. 179 E) that a desire to study the Heraclitean philosophy at Ephesus, its birth-place and metropolis, had induced Plato to travel to that city. Now it was surmised long ago by Schleiermacher (*Werke, Philosophie*, II. p. 145) and Creuzer (*Symbolik*, II. p. 601 sq.) that the philosophy of Heraclitus was to a certain extent Zoroastrian; and this has been completely demonstrated quite lately by Gladisch (*Heraclitos und Zoroaster*, Leipsig, 1859). At the time when Heraclitus lived Ephesus was a Persian city, and Dareius, the devoted champion of Ormuzd, had made it one of the western seats of his own peculiar religion. Artemis, who was worshipped there, was a Persian fire-goddess, not unconnected with astronomical references, as appears from the representation of the Zodiac with which her neck was adorned. The sacred fire burned upon her altar, and her priests bore the Persian name of Μεγάβυζοι. That the Persians recognised their own worship at Ephesus appears from the fact that, when they destroyed other temples in the Greek cities, they treated the temple of Artemis with the utmost reverence. The connexion of Heraclitus himself with this Persian worship is shown by the story (Diog. Laert. ix. 6) that he offered up his book as a dedication in the temple of Artemis. And that the coincidences, which we can now discover, between his philosophy and that of Zoroaster, must have been fully recognised in his own time, that, in fact, he was regarded at the court of Susa as the great Zoroastrian preacher of the distant west, is indicated by the statement (Clem. Alex. *Strom.* i. 14, p. 354, Potter) that Dareius sent him an invitation to the Persian capital, which he declined. Although the correspondence in Diogenes Laertius (ix. 12 sq.) is probably a forgery, it confirms the general impression that Heraclitus was regarded from the earliest times as a disciple of Zoroaster. In a passage of Plutarch (*adv. Colot.* 14, p. 556, Wyttenb.) mention is made of a book called *Zoroaster*, by Heraclitus; but the context shows that Plutarch is speaking of writers subsequent to Plato, and it is clear that we ought to read Ἡρακλείδου instead of Ἡρακλείτου (Bernays, *Rhein. Mus.* 1848, p. 93). Still the corruption itself seems to show that there was a book by Heraclitus entitled Ζωροάστρης τὸ περὶ τῶν ἐν ἄδου, the other title quoted, namely, τὸ περὶ τῶν φυσικῶς ἀπορουμένων, being the work of Heraclides, in which Plato's theories were controverted. If this was the case "the Zoroaster, concerning those in Hades," would be a probable title for the Ephesian tale, which was the original form of Plato's cosmical apologue.

Be that as it may, we find enough in the fragments of Heraclitus to show that his peculiar views were in accordance with the most characteristic details in the myth before us. According to Plato the universe is held together by a straight column of light—that is, as the commentators cited by Suidas (p. 3529 B, Gaisford) give it—"a sort of cylinder of ætherial fire around the axis" (οἱ δὲ κύλινδρον τινα πυρὸς αἰθερίου περὶ τὸν ἄξονα ὄντα),

and to this are attached the ends of the girding-bands of heaven and earth. Now it is known that the key-stone of the philosophy of Heraclitus was the well-known saying, "that a harmony of tension, like that of the lyre and the bow, held together the discordant elements of the universe" (*παλίντονος ἁρμονίη κόσμου, ὄκωσπερ λύρης καὶ τόξου*. Plato, *Sympos.* p. 187 A. Plutarch, *Is. et Os.* 45, *De Tranq. Anim.* 15. *Eudem. Eth.* VII. 1; see Schleiermacher, *Werke, Philos.* II. pp. 65 sqq. Gladisch, *Zeitschrift f. d. Alterthumswiss.* 1846, nos. 121, 122). To say nothing of the fact that the lyre and the bow were the symbols of the fire-god, whom the Greeks worshipped as Apollo, the epithet *παλίντονος* shows that the musical harmony of Heraclitus presumed a constant resistance and a tendency to dissolution unless this resistance was controlled. And this, as we know, was the doctrine of Zoroaster. For our present purpose, it is most important to observe that Heraclitus, in common with Zoroaster, maintained that fire was this controlling bond which held all things together (Aristot. *Phys.* III. 4: *περιέχειν ἅπαντα καὶ ἅπαντα κυβερνᾶν*. Ritter, *Gesch. d. Ion. Phil.* p. 145: "Die grosse, die Welt umfassende Feuermasse"). And this is clearly the meaning of Plato in the passage before us. Then again, if Lachesis spins any threads with her ever-whirling spindle, they must be threads derived from this world-surrounding fire; for her spindle is suspended from the extremities of the bands which encompass and constrain the universe. Now it was the doctrine of Heraclitus and Zoroaster that the soul of man was a particle of the fire which surrounded and governed the world (Sext. *Empir. adv. Matth.* VII. 130: *ἡ ἐπιζευθεῖσα τοῖς ἡμετέροις σώμασιν ἀπὸ τοῦ περιέχοντος μοῖρα*. Macrobius, *Somn. Scip.* I. 14: Heraclitus *physicus animam dixit scintillam stellaris essentiae*). And as the main purpose of Plato's apologue is to show, how, as the result of Lachesis' spinning, the souls after a certain period return to bodily life, we recognise in this the doctrine of Heraclitus, that the heavenly body is the seed of the generation of the universe and the measure of an appointed period (Stobæus, *Ecl. Phys.* I. 5, p. 178: *τὸ αἰθέριον σῶμα σπέρμα τῆς τοῦ παντὸς γενέσεως καὶ περιόδου μέτρον τεταγμένης*); that when we live our souls die and are buried in us, but that when we die our souls revive and live (Sext. *Empir. Hypot.* III. 230: *ὅτε μὲν ἡμεῖς ζῶμεν τὰς ψυχὰς ἡμῶν τεθνᾶναι καὶ ἐν ἡμῖν τεθάρθαι, ὅτε δὲ ἡμεῖς ἀποθνήσκομεν τὰς ψυχὰς ἀναβιοῦν καὶ ζῆν*), or, as he also expressed it, that "men are mortal gods and gods are immortal men, living when men die and dying during the life of men" (*Fragm.* 51 b; Heraclid. *Alleg. Hom.* p. 442 sq.: *ἄνθρωποι θεοὶ θνητοί, θεοὶ τ' ἄνθρωποι ἀθάνατοι, ζῶντες τὸν ἐκείνων θάνατον, θνήσκοντες τὴν ἐκείνων ζῶν*).

Without carrying these parallels any farther, I entertain little doubt as to the truth of the tradition that Plato derived the basis of the apologue, which he put into the mouth of "Er the son of Armenius the Pamphylian," from some writing by Heraclitus, in which Zoroaster was so designated. With this he had combined *ad libitum* the numerical speculations of the Pythagoreans, which Aristotle expressly connects with the harmonies of the celestial spheres (*de Cælo*, II. 9, § 7). And of course the whole had been distilled in the alembic of his own peculiar genius. Why he or Heraclitus called Zoroaster by the monosyllabic name *Er* I cannot presume to determine¹. But Arnobius (I. 12) designates him both as an

¹ I have suggested elsewhere (*New Cratylus*, p. 143, note, Edit. 3) that Ἡρ ὁ Ἀρμενίου τὸ γένος Παμφύλου means that the Arians, as they appeared in Pamphylia, called themselves

descendants of the Armenians. It is at any rate remarkable that *Airyā* is the Zendic form of the Sanscrit *Ārya*.

Armenian and as a Pamphylian. In the time of Plato the Armenians spoke Persian (Xen. *Anab.* iv. 5, § 34), and their deities bear Persian names (see Gosche, *de Ariana ling. gentisque Armeniacæ indole*, pp. 8 sqq.). And as it was the nearest seat of the Persian language and religion, the Greeks of Asia Minor may have regarded it as the original home of that system of worship. With regard to Pamphylia, the battle of the Eurymedon in B.C. 466, shows that this province was the most westerly of the Persian possessions on the sea-board of Asia Minor towards the close of their great war with Greece, and there may have been some special traces of the Zoroastrian worship in this district (see Creuzer, *Symbolik*, II. p. 600).

As far as the limits imposed on me have allowed, I have now discussed the cosmical system delineated in the 10th book of the *Republic*, according to the plan which I proposed to myself at the outset. I shall be very glad if I have succeeded in throwing some new light on a difficult and striking passage in Plato's greatest work, and if I have awakened an interest in the curious question how far Heracleitus mediated between the Arian sage, who influenced the Asiatic mind for so many centuries, and the great Greek philosopher, who has been accepted as an intellectual guide by the profoundest of European speculators.

CAMBRIDGE,

16 February, 1859.

V. *On the Origin and Proper Use of the word ARGUMENT.* By J. W. DONALDSON, D.D.
late Fellow of Trinity College, Cambridge.

[Read November 28, 1859.]

CAMBRIDGE Philosophers, like the Cambridge whigs of the old epigram, "admit no force but argument." It cannot therefore be considered altogether inappropriate, if the Cambridge Philosophical Society is invited to consider as a special question the proper value of the word, which expresses the essential characteristic of all our proceedings. For if we do not succeed in producing at least "an argument" in favour of the theories which we propound in this room, we are not likely to stand justified either to ourselves or to our brethren on the continent, whose suffrages also we seek to obtain.

As the discussion on which I propose to enter, will carry us from philology to logic and rhetoric, and will touch upon English lexicography, it will not pass lightly over the surface; but I will endeavour to make it as little tedious as possible.

The true analysis of the verb *arguo* has long been known to Latin etymologers. It is a notorious fact that the prefix *ar* very often represents the preposition *ad*. Thus we have *arvocare*, *arvehere*, *arfari*, *arvolare*, &c. for *advocare*, *advehere*, *adfari*, *advolare*, &c.; we have *arcubiæ* for *accubiæ*, *arbiter* from *adbitere*; we have a double instance of the change from *d* to *r* in *arcesso* and *accerso* compared with the original form *ad-ced-so* = *accedere sino* (*Varronianus*, p. 352); even by itself the preposition *ad* is sometimes written *ar*, as in *Plautus*, *Truculentus*, II. 2, 17: *ar me advenis*; and we have the same change in other words, as in *auris* by the side of *audio*, and *meridie* for *medii die*. There cannot then be any doubt that *arguo* is a verb compounded with *ad*. But there is no simple verb corresponding to the second part of the compound as it stands, and it has long been seen that the verb involved is *gruo*, which is not found as a simple form, but appears in the familiar compounds *con-gruo* and *in-gruo*. The omission of the *r* is due to the form of the prefix, and there are many instances in which an *r* has dropt out after another consonant, when there is, as in *ar-gruo*, a clashing rhotacism. Thus we have *crebesco* for *crebresco*, and *præstigiæ* for *præstrigiæ*; and the name of *Cambridge* is an example in point, for the original form of the name was *Grantan-bryoga*, which was softened through *Gram-bridge* into *Cam-bridge*, so that the river *Cam* itself has derived its designation from the mutilated compound. But although there is no novelty in this analysis of *arguo*, the true meaning of the verb, especially with reference to its participle *argutus*, has never been indicated. For those who have seen in it the verb *gruo* have been contented to regard this form as merely *ruo* with a guttural prefix. Now this supposition is set aside not only by the form *obrütus* compared with *argütus*, but also by the impossibility of accounting for the meanings of *argutus* by any reference to those of *ruo*. It appears to me that *gruo* should be compared with the Greek *κρούω*, according to the principle that *κ*

before a liquid in Greek, becomes *g* in Latin, as in Ἀκράγας, Κνίδος, Κνωσσός, κράβατος, Κρυμώεις, Πρόκνη, compared with *Agrigentum*, *Gnidus*, *Gnossus*, *grabatus*, *Grumentum*, *Progne*; and I believe that the Greek κρούω will furnish us with a connecting link for all the meanings of the compound now before us. For κρούω means “to dash one thing against another,” especially for the purpose of making a shrill ringing noise. Thus we have κρούειν τὴν θύραν, “to knock at the door,” κρούειν χεῖρας “to clap the hands together,” κρούειν κιθάραν “to strike the lyre,” κρούειν τὰς ἀσπίδας πρὸς τὰ δόρατα “to clash the shields against the spears,” and above all κρούειν κέραμον “to strike an earthen vessel, in order to test its soundness,” as in Plat. *Theætet.* p. 179 D: σκεπτέον τὴν φερομένην οὐσίαν διακρούοντα εἴτε ὑγιᾶς εἴτε σαθρὸν φθέγγεται. Hence κρούειν signifies generally to examine, test, try, prove, like ἐλέγχειν and δοκιμάζω, as in Plat. *Hippias Major*, p. 301 B: τὰ μὲν ὅλα τῶν πραγμάτων οὐ σκοπεῖς, κρούετε δὲ ἀπολαμβάνοντες τὸ καλὸν καὶ ἕκαστον τῶν ὄντων ἐν τοῖς λόγοις κατατέμνοντες.

It will not be difficult to show that these usages of κρούω contain the clue to the primary and proper meaning of *arguo* and *argutus*, compared with *congruo* and *ingruo*. For *congruo* means “to dash or clash together,” like συγκρούω. Thus Seneca *Quæst. Nat.* VII. 9: “Zenon congruere judicat stellas et radios inter se committere;” Valerius Flaccus VI. 58: “linguisque adversus utrinque congruit et tereti serpens dat vulnera gemmæ.” Similarly *ingruo* means “to dash down upon something,” like ἐπισκήπτω. Thus Vergil. *Æneid.* XII. 284: “ferreus ingruit imber.” Accordingly, *arguo* is προσκρούω, that is, “to knock against something” especially for the purpose of making it ring or testing its soundness; and *argutus* means “made to ring;” hence, “making a distinct, shrill noise,” “loud,” “clear-sounding,” “significant,” “expressive,” or, with reference to the secondary and most common meaning of its verb, *argutus* signifies, “brought to the proof,” “thoroughly tested, sound, accurate, and to be depended on.” That these connected meanings are really borne by *arguo* and its participle may be shown by a selection of examples. As distinguished from *accuso*, which means “to bring a formal accusation” (κατηγορῶ), *arguo* denotes “to put a thing to the test,” “to examine and prove it” (κρούω, ἐλέγγω). This is clear from the passages in which the two words appear together, as in Cicero *pro Rosc. Amer.* c. 41: “servos ipsos neque accuso, neque arguo;” *pro Ligar.* 4, § 10: “arguis fatentem—non est satis—accusas eum.” Hence such phrases as: “degeneres animos timor arguit” (Vergil. *Æn.* IV. 13), “fear brings to the test, *i. e.* betrays, ignoble minds,” and: “apparet virtus arguiturque malis” (Ovid, *Trist.* IV. 3, 80), “virtue is made plain and tested by misfortunes.” The primary meaning of *argutus*, and therefore of *arguo*, is best seen in those phrases where it signifies “ringing,” “making a shrill, clear, and loud noise,” as *argutum forum*, “the noisy forum,” *argutum æs*, “a shrill-sounding blade,” *argutæ chordæ*, “the sounding strings” (cf. κρούειν κιθάραν), *argutiæ vallis*, “the clear-ringing echoes of the valley” (*Columella*, III. 9, 6, who adds, “quas Græci ἤχους vocant”), and the like. By a natural transition, we have such usages as: “oculi nimis arguti, quemadmodum animo affecti simus, loquuntur” (Cicero, *Leg.* I. 9), “expressive, speaking eyes declare the feelings of our minds;” conversely, “manus autem minus arguta, digitis subsequens verba, non exprimens” (Id. *de Orat.* III. 59), “the hand less significant, following the words with its gesture, not expressing them;” *argutus sententiis* (Id. *de clar. orat.* 17), “expressive in his sentiments;” and in opposition to *acutus*,

which often seems to correspond in meaning to *argutus*, just as *ὀξύς* is used to signify a shrill, sharp sound, we have in Cic. *de opt. gen. oratorum*, 2, § 5: “sententiarum totidem genera sunt, quot diximus esse laudum. Sunt enim docendi acutæ, delectandi quasi argutæ, commovendi graves.” With reference to the secondary and most usual sense of *arguo* “to try and prove,” we have *argutus* as a regular passive participle in Plautus, *Amphit.* III. 2, 9: “ita me probri, stupri, dedecoris a viro argutam meo!” and in the inferential sense of “thoroughly tested,” “sound and accurate,” we have such phrases as that in Horace, *Ars Poetica*, 364: “poesis—judicis argutum quæ non formidat acumen,” “poetry which dreads not the nice and accurate discernment of a critic,” where again the word is virtually distinguished from *acutus*.

The double compounds *co-arguo* and *red-arguo* do not require any special examination, and it is only necessary that I should remark in passing, that they indicate the early use of *arguo* as a well-defined and virtually simple verb.

Such being the true meaning of the verb *arguo* and its participle *argutus*, there can be little doubt as to the signification of the derivative noun *argumentum*. Whatever may be the metaphysical explanation of the fact, there can be no doubt of the fact that many nouns in *-mentum* denote the thing which carries out the action of the verb. Thus we have *ali-mentum*, “that which nourishes,” *ar-mentum*, “that which ploughs,” *atra-mentum*, “that which makes a black mark,” *blandi-mentum*, “that which allures,” *condi-mentum*, “that which seasons,” *docu-mentum*, “that which shows,” *fo-mentum*, “that which warms,” *horta-mentum*, “that which encourages,” *irrita-mentum*, “that which excites,” *leni-mentum*, “that which alleviates,” *monu-mentum*, “that which reminds,” *nutri-mentum*, “that which nurtures,” *orna-mentum*, “that which adorns,” *pig-mentum*, “that which paints,” *testa-mentum*, “that which testifies,” *vesti-mentum*, “that which clothes,” &c. In the same way *argu-mentum* means *id quod arguit*, “that which makes a substance ring, which sounds, examines, tests, and proves it.” Hence the word is constantly used by the best writers to denote the outward and visible sign, from which something is inferred, the test, which is accepted as conclusive. Thus we have in Cicero, *Verr.* II. 6: “quæ res pertenui nobis argumento indicioque patefacta est.” Id. *Cat.* III. 5, § 13: “mihi quidem quum illa certissima sunt visa argumenta atque indicia sceleris, tabellæ, signa, manus, denique uniuscujusque confessio, tum multo illa certiora, color, oculi, vultus, taciturnitas.” Ovid, *Metam.* IV, 761: “lotique lyræque, tibiaque, et cantus, animi felicia læti argumenta, sonant.” Pliny, *H. N.* XII. 15, 68: “nostri unguentarii murræ digerunt haud difficulter odoris atque pinguedinis argumentis.” Hence *argumentum* denotes the outward appearance of a thing, that which it bears on the face of it, as when Pliny says (*H. N.* XXII. 15): “ex argumento nomen accipit scorpio herba: semen enim habet ad similitudinem caudæ scorpionis.” That this is also the meaning implied, when the word signifies the theme or subject of some composition, especially the plot of a play, might be inferred from the distinction given by Quintilian, who says (*Inst. Or.* II. 4, § 2): “narrationum tres accepimus species: *fabulam*, quæ versatur in tragœdiis atque carminibus, non a veritate modo, sed etiam a forma veritatis remotam; *argumentum*, quod falsum, sed vero simile, comœdiæ fingunt; *historiam*, in qua est gestæ rei expositio.” It is, however, more reasonable to suppose that this meaning may have flowed from the logical use of the term, which I am about to consider, and which, as we shall see, would give to *argumentum* occasionally the same force as our word “topic” in its secondary

meaning. This logical application of *argumentum* is by far the most important function of the term, and must be carefully examined.

If we analyze any process of reasoning, we shall see that it resolves itself into the discovery of some connecting link between the premises and the conclusion. The foundation of all reasoning is the common notion that two things agree or disagree with one another according as they agree or disagree with some third thing. Whether we reason syllogistically or inductively, the test of our reasoning is the middle term, that is, the third idea which helps us to form a judgment. Thus if I wish to assert that Uncle Tom and his fellows are reasonable beings, I find the test of my reasoning in the middle term "man," and my argument runs syllogistically:

Omnes *homines* præditi sunt ratione;
Afri sunt *homines*;
Ergo, Afri sunt præditi ratione.

Or if I wished to prove inductively that all men are reasonable beings, I must find my middle term in an examination of all the varieties of the human race, and my induction will run thus:

Europæi, Asiatici, Afri, Americani sunt ratione præditi;
Sed *Eur. As. Afr. Am.* sunt homines;
Ergo, omnes homines sunt præditi ratione.

Hence the art of topics is really the discovery of middle terms. And *argumentatio*, or the dealing with *argumenta*, is the application of this test or rule, to prove whether this reasoning rings sound or cracked, namely, to try whether the third term really does agree with the other two. Now this is Cicero's definition of an *argumentum*. He says, *Acad.* I. 8: "Argumenti conclusio, quæ est Græce ἀπόδειξις, ita definitur: ratio, quæ ex rebus perceptis ad id, quod non percipiebatur, adducit," that is, by the discovery of the middle term or link of connexion between the subject and predicate of the conclusion sought; or, as he expresses it elsewhere, *Brutus*, 32: "habere regulam, qua vera et falsa judicantur, et quæ, quibus positis, essent, quæque non essent consequentia." The *argumentum* or test, which this *regula* applies, is obviously unnecessary in those cases which do not require or admit of formal proof; and thus Cicero says, *de nat. Deor.* III. 4: "neque ego in causis, si quid est evidens, de quo inter omnes conveniat, argumentari soleo." There can of course be no *argumentum* or middle term in a truism; but in all cases of *ratiocinatio* this rule must be applied, and the *topica ars*, or art of discovering arguments, is, as Aristotle defines it, μέθοδον εὐρεῖν ἀφ' ἧς δυνησόμεθα συλλογίζεσθαι περὶ παντός τοῦ προτεθέντος προβλήματος ἐξ ἐνδόξων καὶ αὐτοὶ λόγον ὑπέχοντες μὴθὲν ἐροῦμεν ὑπεναντίον.

It will be observed that Aristotle says here ἐξ ἐνδόξων, and he means of course that the purpose of his treatise is "to discover a method by which we shall be able to syllogize about every proposed question from probabilities, and that when we ourselves sustain an argument, we may not advance any thing that is contradictory." Readers of Aristotle do not require to be reminded that the philosopher treats separately of the different kinds of syllogisms. For while the *Prior Analytics* discuss the syllogism in general, the *Posterior Analytics* examine the demonstrative syllogism, the *Topics* enlarge on the probable syllogism, and the *Sophistical Elenchi* expose the captious or dishonest syllogism. The τόπος, however, or "place," is pro-

perly defined as the seat of the *argumentum*, where it lies hid and may be found, or in other words, the place in which we look for middle terms. Thus Cicero says (*Top.* c. 2): “cum pervestigare argumentum aliquod volumus, *locos* nosse debemus...Itaque licet definire *locum* esse *argumenti sedem*.” Similarly, Quintilian, *I. O.* v. 10, § 20: “*locos* appello *sedes argumentorum*, in quibus latent, ex quibus sunt petenda.” And again (v. 12, § 17): “*ipsas argumentorum* velut *sedes* non me quidem omnes ostendisse confido, plurimas tamen.” Now there must be an argument or middle term for every kind of syllogism. Therefore there must be τόποι or “places” in demonstrative as well as probable reasoning; and in point of fact the *axiom* is the τόπος in the demonstrative syllogism, just as the *common places*, or general principles of probability, are the seats of arguments in the probable syllogism. In fact, every general statement or common principle might be called a τόπος or στοιχείον. But the investigation of arguments in scientific demonstration belongs to the different sciences, and cannot be discussed generally. So that practically the art of topics belongs only to a “probable,” or, as Aristotle calls it, “dialectical and rhetorical” argumentation. Thus Aristotle says (*Rhet.* i. 2, § 21): λέγω διαλεκτικούς και ρητορικούς συλλογισμούς είναι περι ὧν τοὺς τόπους λέγομεν, “I call dialectical and rhetorical synonyms those in reference to which we use the expression *places*.” And again (ii. 26, § 1): ἔστι γὰρ στοιχείον και τόπος εἰς ὃ πολλά ἐνθυμήματα ἐμπίπτει, “an element or place is that which contains several rhetorical arguments.” And as distinguished from εἶδη he says of the τόποι of rhetoric (*Rhet.* i. 2, § 22): καθάπερ οὖν και ἐν τοῖς Τοπικοῖς και ἐνταῦθα διαιρετέον τῶν ἐνθυμημάτων τά τε εἶδη και τοὺς τόπους ἐξ ὧν ληπτέον. λέγω δὲ εἶδη μὲν τὰς καθ’ ἕκαστον γένος ἰδίας προτάσεις, τόπους δὲ τοὺς κοινούς ὁμοίως πάντων, “as in the *Topics* we must distinguish here the *species* and the *places* from which we may derive our arguments. Now I give the name of *species* to the propositions peculiar to the several kinds of rhetoric, and that of *places* to those which are common to all alike.” I have rendered the term ἐνθύμημα by “argument,” because although an enthymeme may be formally expressed as a regular syllogism, it is generally put as a mere argument or reason why. Thus we may say, “Cæsar was justly killed, because he was a tyrant;” or, “And I will tell you the reason why,—he was a tyrant,” which is equivalent to:

Cæsar was a tyrant;

Tyrants are justly slain;

Therefore Cæsar was justly slain.

The middle term here is “tyrant,” which is the *argumentum* of the syllogism; and the common-place is “tyrannicide is justifiable.” In ordinary conversation the *enthymeme* or sentiment is used indifferently for the argument and the place of the argument. And hence it is that “argument” and “topic” are used without distinction to signify the theme or subject of a composition, the essential purport of a discourse. The passage in which Aristotle most directly contrasts the *enthymeme* or “sentiment” with the *syllogism* or “process of reasoning” has given rise to a great deal of discussion. The words (*Rhet.* i. 2, § 13) are as follows. After pointing out briefly the unsuitableness of the strictly logical syllogism and induction to the ordinary purposes of persuasion, the philosopher adds: ὥστ’ ἀναγκαῖον τό τε ἐνθύμημα εἶναι και τὸ παράδειγμα περι τῶν ἐνδεχομένων ὡς τὰ πολλά ἔχειν και ἄλλως τὸ μὲν παράδειγμα ἐπαγωγὴν τὸ δ’ ἐνθύμημα συλλογισμόν και ἐξ ὀλίγων τε και πολλάκις

ἐλαττόνων ἢ ἐξ ὧν ὁ πρῶτος σὺλλογισμὸς, *i. e.* “it follows that the enthymeme and the example, which are, the one a sort of syllogism, and the other a sort of induction, are generally conversant with contingent propositions, and composed of few of these, and oftener fewer than the syllogism in its original form contains.” From this description it was supposed that the enthymeme differed from a syllogism by regularly suppressing one of its premises. But Julius Pacius*, after him Facciolati†, and finally Mr De Quincey‡, have shown beyond all question that this accident, which might happen to a logical syllogism, and which Aristotle describes as “frequent,” and not invariable, cannot be the essential distinction of an enthymeme, which must consist in the nature of the matter,—that of the syllogism being fixed and apodeictic, that of the enthymeme probable and drawn from the province of opinion. As Aristotle himself says in his *Prior Analytics* (II. c. 27, p. 70 A. 10): ἐνθύμημά ἐστι συλλογισμὸς ἐξ εἰκότων ἢ σημείων, which Sir W. Hamilton renders, “enthymeme is distinguished from pure syllogism as a reasoning of peculiar matter from signs and likelihoods.” And in accordance with this, while Aristotle says (p. 1355 A. 6), ἔστι δ' ἀπόδειξις ῥητορικὴ ἐνθύμημα: he also says (1359 A. 7), τὰ γὰρ τεκμήρια καὶ τὰ εἰκότα καὶ τὰ σημεία προτάσεις εἰσὶ ῥητορικαί (cf. p. 1357 A. 32).

The frequent abridgment of the enthymeme arises from its matter, as appears from the illustration given by Aristotle in the passage already quoted from his *Rhetoric*. “If,” he says, “any of these—the contingent propositions that make up the enthymeme—be known, it is not necessary to mention it, as the hearer may supply it himself. For instance, to convey the information that Dorieus was conqueror in a contest where a chaplet is the prize, it is sufficient to say that he conquered in the Olympic games: but it is needless to add that the Olympic games confer such a prize as a chaplet; for every body knows that.” If we put the syllogism here represented in its full form, it would be of course

The Olympic games are a crowned contest;
Dorieus conquered at the Olympic games;
Therefore he won a chaplet.

But the enthymeme or rhetorical proof would be sufficiently expressed if we said, “Dorieus has got a crown, for he has conquered at Olympia.” And as the argument or middle term is the only point of importance, the enthymeme generally contents itself with this brief statement of the reasoning implied. The definition, then, given by Julius Pacius (*Institutiones Logicae*, p. 67) is quite correct: “*Enthymema* est syllogismus ex verisimilibus, vel signis vel indiciis, in quo plerumque altera propositio omittitur, tanquam nota.” Thus to take one of his examples, the enthymeme is expressed fully and syllogistically, if we say:

Pittacus est probus;
Pittacus est sapiens;
Ergo, *Sapientes sunt probi.*

But the more common way of putting it would be as a mere argument: *Sapientes sunt probi, nam Pittacus est probus*, which of course does not prove the necessity, but only the possibility, or at most the probability of the conclusion. It is scarcely necessary to add that the four kinds of arguments which are generally used in rhetoric, the *argumenta ad verecundiam, ad*

* *De enthymemate.*

† *Orat. XII. Acroases, &c. Patavii, 1759, p. 227.*

‡ *Blackwood's Magazine, XXIV. p. 387.*

ignorantiam, ad hominem and *ad judicium*, are not distinguished by forms and processes of reasoning, but merely by the topic selected; so that in this use the word "argument" bears its proper meaning. This examination also explains how the word "topic," which is substituted for *τόπος* or place, has become a synonym for "argument,"—the rhetorical argument being found in the "common-place,"—and how it has come to pass that both words are used to denote the pith or marrow, the real contents, the subject-matter, the hypothesis or starting-point of that which is discussed, argued, or even pictorially represented.

In its logical use, then, by the best writers, *argumentum* does not mean the syllogism, but that on which the syllogism depends. It is the *ἔλεγχος* or *βάσανος*, the test and touchstone of the reasoning, and in conformity with its other applications it denotes that which tries the soundness of the object to be proved. As *βάσανος* is used in exactly the same sense as *argumentum*, e. g. Soph. *Æd. T.* 499, it is worth remarking that the *βάσανος* or *lapis Lydius*, which was used as a touchstone of gold, was called *lapis index*. Ovid, *Metamorph.* II. 706: *in durum lapidem qui nunc quoque dicitur index*. And I have shown that *argumentum* and *indicium* are all but synonymous; cf. Juvenal, x. 70: *quibus indicia, quo teste probarit*.

It is satisfactory to know that in spite of the popular abuse of the term, which has been sanctioned by the authority of the text-books at Oxford*, the classical usage of *argumentum* is still maintained by the best logicians. "In technical propriety," says Sir W. Hamilton (*Edinb. Rev.* Vol. LVII. No. 115, p. 218), "*argument* cannot be used for *argumentation*, as is done by Dr Whately—but exclusively for its *middle term*. In this meaning the word (though not with uniform consistency) was employed by Cicero, Quintilian, Boëthius, &c.; it was thus subsequently used by the Latin Aristotelians, from whom it passed even to the Ramists; and this is the meaning which the expression always first and most naturally suggests to a logician." And in a note he adds: "Ramus in his definition indeed abusively extends the word to both the other terms; the middle he calls the *tertium argumentum*. Throughout his writings, however,—and the same is true of those of his friend Talæus—*argumentum*, without an adjective, is uniformly used for the middle term of a syllogism; and in this he is followed by the Ramists and Semi-Ramists in general."

The academical disputations which used to be practised in our public Schools at Cambridge departed from this proper usage of the word argument. It was generally supposed that the argument included the three constructive conditional syllogisms, which were generally produced by an opponent in these disputations; and while the consequent of the first syllogism was always *cadit quæstio*, and that of the second either *valet consequentia*, or *valet minor*, the third always concluded with either *valet consequentia et argumentum* or *valet minor et argumentum*. It is possible that this lax usage was due to the influence of Crackanthorpe and Wallis, who were regarded as authorities at Cambridge as well as at Oxford. Our mathematicians, on the other hand, seem to have been more happy in their technical use of the word *argument* as an astronomical term. "*Argument*, in Astronomy," says Hutton (*Phil. and Math. Dict.* I. p. 144), "is an arc given, by which another arc in some proportion to it is found."

* We must of course except Mr Mansel's edition of Aldrich, where the necessary correction is introduced (*artis logica rudimenta*, ed. III. p. 63). Aldrich himself had said: "tertia pars

logicæ agit de *argumento* sive *sylogismo*, quod est signum tertie operationis intellectus: nempe *Discursus* vel *Rationium* propositionibus expressum."

Hence, as Maddy says (*Astronomy*, Art. 266, p. 172), "the angle at the sun's center between the radius vector of the planet in its orbit, and the ascending node, is called the *Argument of Latitude*. The argument of latitude together with the longitude of the ascending node is called the *Longitude of the Planet in its Orbit*." In this use of the term *argument*, to denote an angle regarded as the means of determining something else, we have a very distinct reference to the classical meaning of the word as nearly synonymous with *indicium*, and as implying the outward and visible sign from which something is inferred. Not only in this technical sense, but generally, an angle suggests itself as such an *indicium* of measurement, and Sir Thomas Browne cannot find, in the resources of his quaint vocabulary, a stronger expression for littleness than the smallest conceivable angle included between diameters which grow shorter and shorter. He says (*Hydriotaphia* ad fin. Vol. III. p. 496, ed. Wilkins): "the most magnanimous resolution rests in the Christian religion, which trampleth on pride, and sits on the neck of ambition, humbly pursuing that infallible perpetuity, unto which all others must diminish their diameters, and be poorly seen in angles of contingency." Such an angle is an *argument* of insignificance, if there is any meaning in language.

In its popular acceptance, the word *argument* is employed, like all popular terms, with great vagueness and laxity. When the word is used most legitimately, its meanings may perhaps be reduced to three: (1) a proof or means of proving; (2) a process of reasoning or controversy made up of such proofs; (3) the subject-matter of any discourse or writing, or even of a picture. After what has been said, it is perhaps needless to remark that only the first and third of these meanings are supported by the classical significations of *argumentum*, the second being represented by *argumentatio*. And yet our logical writers, who ought to be most accurate, formally adopt the second. The following examples from the classical English poets will be sufficient to illustrate the three ordinary uses of the term: (1) argument is a proof or means of proving. Shaksp. *Henry VI.* 1st pt. Act v. sc. 2:

In argument and proof of which contract
Bear her this jewel, pledge of my affection.

Cf. *Twelfth Night*, III. 2:

This was a great argument of love in her toward you*.

(2) Argument is reasoning. Butler, *Hudibras*, I. 1, v. 72:

He'd undertake to prove by force
Of argument, a man's a horse.

So Dryden (*Hind and Panther*):

Bare lies with bare assertions they can face,
But dint of argument is out of place.

(3) Argument is subject-matter. Shaksp. *Love's Labour's Lost*, Act v. sc. 1:

He draweth out the thread of his verbosity finer than the staple of his argument.

By a slight change from the first of these meanings, an *argument* may denote that which furnishes the test or proof, as when *Timon* says (Act II. sc. 2):

* In this sense too we have 3 Hen. VI. Act II. Scene 2: "inferring arguments of weighty force." and again Act III. Scene 1: "inferreth arguments of mighty strength."

If I would broach the vessels of my love,
 And try the argument of hearts by borrowing,
 Men and men's fortunes could I frankly use.

By a slight change from the second meaning, *argument* denotes a quarrel or dispute, as in *Love's Labour's Lost*, III. 1: "how did this argument begin?"

And instead of subject-matter, it may denote the theme or subject of the discourse, as in *Henry V.* III. 7: "Nay, the man hath no wit, that cannot from the rising of the lark to the lodging of the lamb, vary deserved praise on my palfrey: it is a theme as fluent as the sea; turn the sands into eloquent tongues, and my horse is argument for them all: 'tis a subject for a sovereign to reason on."

Hence *argument*, in our Elizabethan writers, means the grounds or moving-cause of any thing, as when Hamlet says (IV. 4):

Rightly to be great
 Is, not to stir without great argument.

It means especially a cause of quarrel, as when Troilus says (*Tr. and Cress.* Act I. sc. 1):

I cannot fight upon this argument:
 It is too starved a subject for my sword.

Or when *Henry V.* (Act III. sc. 1) speaks of:

Fathers, that, like so many Alexanders,
 Have, in these parts, from morn till even fought,
 And sheath'd their swords for lack of argument.

It may even mean an object of revenge, as when the Duke Frederick says (*As You Like it*, Act III. sc. 1):

Were I not the better part made mercy,
 I should not seek an absent argument
 Of my revenge, thou present.

The commentators on Shakspeare suppose that he uses the word *argument* to denote *conversation* in *Much Ado about Nothing*, III. 1:

Signior Benedick,
 For shape, for bearing, argument, and valour
 Goes foremost in report through Italy.

But it most probably signifies, as Johnson says, *discourse*, or *power of reasoning*, and in the passage which they quote for the other meaning (*Hen. IV.* Pt. I. Act II. sc. 2): "It would be argument for a week, laughter for a month, and a good jest for ever," the subsequent words of the Prince show that it means the subject-matter of conversation; for when Falstaff says (Act II. sc. 4), "Shall we have a play extempore?" the Prince answers: "Content:—and the argument shall be thy running away." And in *Much Ado about Nothing*, Act I. sc. 1, Don Pedro says to Benedick: "Well, if ever thou dost fall from this faith, thou wilt prove a notable argument." When Milton (*P. L.* Book VI.) describes shields, as "various, with boastful argument portrayed," he of course uses the word to signify the subject of a picture or device.

It only remains that I should state briefly why I consider the results of this discussion worth

the trouble which I have bestowed upon it. These results have a double reference: (1) to comparative philology; (2) to the terminology of science.

(1) As a question of comparative philology, it is absolutely necessary that something should be done to correct the current statements about *arguo* and *argutus*, which are really disgraceful to Latin lexicography. For while Ramshorn connects *arguo* with the German *wahren* or *gewahren* (*Lat. Synon.* p. 16), and Benfey, who etymologizes through a brick-wall, does not hesitate to connect it with the Greek ἐλέγχω, and the Sanscrit *glaksh* (*Wurzellea.* II. p. 367), Döderlein, who saw long ago that the full form must have been *ar-gruere*, not only fell into the error of supposing that *gruo* was another way of writing *ruo* (*Et. u. Syn.* II. p. 162), but has gone back to Voss's derivation from the Greek ἀργόω, which is also adopted by Pott (*Etym. Forsch.* I. 25), and even supposes two homonyms *arguo*, "to make plain," from ἀργόω, and *arguo*, "to accuse," from *adgruo* (*Et. u. Syn.* v. p. 360). With all this the word *argutus* remains unexplained; and in the interests of scientific etymology I consider it quite worth while to follow out to its logical consequences the simple reasoning that *arguo* is *argruo* or *adgruo*; that as *congruo* is undoubtedly equivalent to συγκροίω, *ingruo* and, therefore, *adgruo* must be compounded of the same verb; and that *argutus*, being the Latin congener of ἐπι-κρουστός, must mean beaten or sounded, and, by implication, emitting a clear, ringing sound. And these results are in strict accordance with the classical usage of the words.

(2) As a question of scientific terminology, I consider it of importance that all words used in exact science should be themselves exact and definite. I have nothing to do with the popular applications of the word *argument*. Usage and convention are the only criteria in that case. Let the word *argument* be employed by poets and prose writers in every sense which is found to be intelligible. But let us protest against the misuse, or the confused, vague, and contradictory uses, of the word as a scientific term by scientific men. Let us require of those who profess to speak correctly, that they should confine the term *argument* to its proper value, namely, a proof, or means of proving, a test, a ground of inference; and that they should not make it coextensive with argumentation, reasoning, and the formal process of proving. Above all, let us be prepared to rebuke and correct any logician who tells us, as Dr Whately does, that in "the strict technical sense," "every argument consists of two parts; that which is proved, and that by means of which it is proved," whereas "in popular use the word argument is often employed to denote the latter of these two parts alone." As if, forsooth, popular use confined a word to one definite meaning, whereas formal logic was permitted to use one and the same word as a capricious homonym! There can be no tyranny surely in demanding that the logician should, like his best predecessors, use the term *argument* to denote the middle term only, namely, the term used for proof, and that all scientific men should, like our mathematicians, be satisfied with the oldest and still most common signification of the word, namely, the means of testing the soundness of a conclusion, the touchstone of the validity of our reasoning.

VI. *Supplement to a Proof of the Theorem that every Algebraic Equation has a Root.* By G. B. AIRY, Esq. *Astronomer Royal.*

[Read Dec. 12, 1859.]

18. IN lately offering to the Society a Proof of the Theorem that every Algebraic Equation has a Root, I assumed (as a thing to be proved by the process) that a root might be expressed in the usual way, by the aggregate of two terms, of which one is real, and the other is imaginary, involving the symbol $\sqrt{-1}$ as an ostensible multiplier. And the proof went by these principal steps. Changing the notation there used for one which is more familiar to us, supposing all the coefficients real, and supposing (for ease of writing) that the equation is of the 8th order, instead of the n th; and assuming the equation to be

$$x^8 + p \cdot x^7 + q \cdot x^6 + r \cdot x^5 + s \cdot x^4 + t \cdot x^3 + v \cdot x^2 + w \cdot x + z = 0;$$

then, adopting the expression $\rho (\cos \theta + \sqrt{-1} \cdot \sin \theta)$ for the form of the root, and making use of Demoivre's Theorem in the expansion of each power, the possibility of satisfying the equation depends upon the simultaneously satisfying the two equations,

$$\rho^8 \cdot \cos 8\theta + p \cdot \rho^7 \cdot \cos 7\theta + q \cdot \rho^6 \cdot \cos 6\theta + r \cdot \rho^5 \cdot \cos 5\theta + s \cdot \rho^4 \cdot \cos 4\theta + t \cdot \rho^3 \cdot \cos 3\theta \\ + v \cdot \rho^2 \cdot \cos 2\theta + w \cdot \rho \cdot \cos \theta + z = 0.$$

$$\rho^8 \cdot \sin 8\theta + p \cdot \rho^7 \cdot \sin 7\theta + q \cdot \rho^6 \cdot \sin 6\theta + r \cdot \rho^5 \cdot \sin 5\theta + s \cdot \rho^4 \cdot \sin 4\theta + t \cdot \rho^3 \cdot \sin 3\theta \\ + v \cdot \rho^2 \cdot \sin 2\theta + w \cdot \rho \cdot \sin \theta = 0.$$

And the object of my former Memoir was, to shew that these two equations can, certainly, be simultaneously satisfied.

19. In the introductory part of this process, a principle is involved to which, on logical grounds, I offer an absolute objection. I have not the smallest confidence in any result which is essentially obtained by the use of imaginary symbols. I am very glad to use them as conveniently indicating a conclusion which it may afterwards be possible to obtain by strictly logical methods: but, until these logical methods shall have been discovered, I regard the result as requiring further demonstration. It is my object in this paper to give the logical certainty to which I allude, to the theorem of the roots of equations.

20. Divested of the idea of imaginary roots, the theorem to be proved is this: "Every expression, of the form of the left side of the equation given above, can be divided without remainder by the quadratic trinomial $x^2 - 2\rho \cdot \cos \theta \cdot x + \rho^2$." And my process will be: to effect the actual division by $x^2 - 2\rho \cdot \cos \theta \cdot x + \rho^2$; to exhibit the form of the remainder; and to shew that the condition of evanescence of the remainder leads to the two equations at the end of Article 18 (the possibility of satisfying which I consider to be demonstrated in the former Memoir).

21. The division can be effected without difficulty by retaining the equation in the form which I have given. But the subsidiary equations are much abbreviated by first multiplying the equation by $\sin \theta$. Assume then that

$$\sin \theta . x^8 + p . \sin \theta . x^7 + q . \sin \theta . x^6 + r . \sin \theta . x^5 + s . \sin \theta . x^4 + t . \sin \theta . x^3 + v . \sin \theta . x^2 + w . \sin \theta . x + z . \sin \theta$$

is equal to

$$\{x^2 - 2\rho \cdot \cos \theta \cdot x + \rho^2\} \times \{\sin \theta \cdot x^6 + P \cdot x^5 + Q \cdot x^4 + R \cdot x^3 + S \cdot x^2 + T \cdot x + V\} + \text{Remainder} :$$

then upon actually performing the multiplication, and comparing coefficients of similar powers of x , we have the following equations :

$$\begin{aligned} P &= \rho \cdot \sin 2\theta + p \cdot \sin \theta ; \\ Q &= 2\rho P \cdot \cos \theta - \rho^2 \cdot \sin \theta + q \cdot \sin \theta ; \\ R &= 2\rho Q \cdot \cos \theta - \rho^2 P + r \cdot \sin \theta ; \\ S &= 2\rho R \cdot \cos \theta - \rho^2 Q + s \cdot \sin \theta ; \\ T &= 2\rho S \cdot \cos \theta - \rho^2 R + t \cdot \sin \theta ; \\ V &= 2\rho T \cdot \cos \theta - \rho^2 S + v \cdot \sin \theta ; \end{aligned}$$

and

$$\text{Remainder} = (2\rho V \cdot \cos \theta - \rho^2 T + w \cdot \sin \theta) x + (-\rho^2 V + z \cdot \sin \theta).$$

22. Solving the equations in order (constantly substituting each value in the two following equations), we obtain,

$$\begin{aligned} P &= \rho \cdot \sin 2\theta + p \cdot \sin \theta . \\ Q &= \rho^2 \cdot \sin 3\theta + \rho p \cdot \sin 2\theta + q \cdot \sin \theta . \\ R &= \rho^3 \cdot \sin 4\theta + \rho^2 p \cdot \sin 3\theta + \rho q \cdot \sin 2\theta + r \cdot \sin \theta . \\ S &= \rho^4 \cdot \sin 5\theta + \rho^3 p \cdot \sin 4\theta + \rho^2 q \cdot \sin 3\theta + \rho r \cdot \sin 2\theta + s \cdot \sin \theta . \\ T &= \rho^5 \cdot \sin 6\theta + \rho^4 p \cdot \sin 5\theta + \rho^3 q \cdot \sin 4\theta + \rho^2 r \cdot \sin 3\theta + \rho s \cdot \sin 2\theta + t \cdot \sin \theta . \\ V &= \rho^6 \cdot \sin 7\theta + \rho^5 p \cdot \sin 6\theta + \rho^4 q \cdot \sin 5\theta + \rho^3 r \cdot \sin 4\theta + \rho^2 s \cdot \sin 3\theta + \rho t \cdot \sin 2\theta + v \cdot \sin \theta . \end{aligned}$$

Then substituting the values of T and V in the expression for Remainder, we find

Remainder =

$$\{\rho^7 \cdot \sin 8\theta + \rho^6 p \cdot \sin 7\theta + \rho^5 q \cdot \sin 6\theta + \rho^4 r \cdot \sin 5\theta + \rho^3 s \cdot \sin 4\theta + \rho^2 t \cdot \sin 3\theta + \rho v \cdot \sin 2\theta + w \cdot \sin \theta\} \times x + \{-\rho^8 \cdot \sin 7\theta - \rho^7 p \cdot \sin 6\theta - \rho^6 q \cdot \sin 5\theta - \rho^5 r \cdot \sin 4\theta - \rho^4 s \cdot \sin 3\theta - \rho^3 t \cdot \sin 2\theta - \rho^2 v \cdot \sin \theta + z \cdot \sin \theta\}.$$

23. Use these symbols, for convenience,

$$\begin{aligned} A &= \rho^8 \cdot \cos 8\theta + \rho^7 p \cdot \cos 7\theta + \rho^6 q \cdot \cos 6\theta + \rho^5 r \cdot \cos 5\theta + \rho^4 s \cdot \cos 4\theta + \rho^3 t \cdot \cos 3\theta + \rho^2 v \cdot \cos 2\theta + \rho w \cdot \cos \theta + z, \\ B &= \rho^8 \cdot \sin 8\theta + \rho^7 p \cdot \sin 7\theta + \rho^6 q \cdot \sin 6\theta + \rho^5 r \cdot \sin 5\theta + \rho^4 s \cdot \sin 4\theta + \rho^3 t \cdot \sin 3\theta + \rho^2 v \cdot \sin 2\theta + \rho w \cdot \sin \theta ; \end{aligned}$$

then it is easily seen that

$$\text{Remainder} = \frac{B}{\rho} \times x + \{A \cdot \sin \theta - B \cdot \cos \theta\}.$$

And now removing the multiplier $\sin \theta$ which was introduced in article 21,

Remainder of the original equation-function, after dividing by $x^2 - 2\rho \cdot \cos \theta \cdot x + \rho^2$,

$$= \frac{1}{\rho} \cdot \frac{B}{\sin \theta} \times x + \left\{ A - \frac{B}{\sin \theta} \times \cos \theta \right\}.$$

And, in order that this Remainder of the original equation-function may = 0, we must have

$$A = 0, \quad \frac{B}{\sin \theta} = 0.$$

24. In the general case of discovery of corresponding values of ρ and θ which make $A = 0$, $B = 0$, (discussed in the former Memoir), θ will have a value which is not = 0 or = a multiple of π . The two equations just found will then be satisfied by the same values of ρ and θ which make

$$A = 0, \quad B = 0.$$

And thus, in the general case, the conditions of divisibility, derived entirely from division of the equation-function by the quadratic trinomial, without any reference to imaginary quantities, are the same as the conditions for satisfying the equation by the substitution of a quantity partly imaginary.

25. The case of $\theta = 0$ requires a special examination. Suppose that it is found by any tentative process that the combination of the values, $\rho = R$, $\theta = 0$, satisfies the equation $A = 0$. Since $\cos \theta$, $\cos 2\theta$, &c. are each = 1, this is the same as saying that

$$R^8 + p \cdot R^7 + q \cdot R^6 + \&c. + z = 0,$$

or that R is a root of the equation $x^8 + p \cdot x^7 + q \cdot x^6 + \&c. + z = 0$. The equation $B = 0$ will be satisfied identically, because (when $\theta = 0$), $\sin \theta$, $\sin 2\theta$, &c., are each = 0. But it does not follow that $\frac{B}{\sin \theta}$, which then takes the form $\frac{0}{0}$, is = 0; and therefore it does not follow that the original equation-function is divisible by $x^2 - 2R \cdot \cos 0 \cdot x + R^2$ without remainder. In order to find the condition of this divisibility, we must find the value of $\frac{B}{\sin \theta}$ when $\theta = 0$.

Since $\frac{\sin n\theta}{\sin \theta}$ ultimately = n , it is evident that $\frac{B}{\sin \theta}$ ultimately = $8 \cdot R^8 + 7p \cdot R^7 + 6q \cdot R^6 + \&c$. Consequently, that the equation-function may be divisible by $x^2 - 2Rx + R^2$, or $(x - R)^2$, it is necessary that R satisfy these two equations

$$R^8 + p \cdot R^7 + q \cdot R^6 + \&c. + z = 0,$$

$$8R^8 + 7p \cdot R^7 + 6q \cdot R^6 + \&c. = 0.$$

These, it is well known in other ways, are the conditions for an equation having two equal roots R .

26. Reverting now to the general investigation; if p , q , r , &c. as far as w , are all = 0, while z has a positive value; then the equation is

$$x^8 + z = 0;$$

and the conditions $A = 0$, $B = 0$, become

$$\rho^8 \cdot \cos 8\theta + z = 0,$$

$$\rho^8 \cdot \sin 8\theta = 0;$$

from which $\cos 8\theta = -1$, $\rho^8 = z$.

If z be a negative quantity = $-z'$, then

$$\cos 8\theta = +1, \quad \rho^8 = z'.$$

The combination of the different values of θ which make $\cos 8\theta = \pm 1$, properly carried out, gives Cotes' Theorem.

27. It will readily be seen that the process here used is perfectly general as regards the order of the equation; the adoption of the 8th order having been made merely for convenience of writing.

G. B. AIRY.

ROYAL OBSERVATORY, GREENWICH,
October 1, 1859.

VII. *On the Syllogism, No. IV, and on the Logic of Relations.* By AUGUSTUS DE MORGAN, F.R.A.S., of Trinity College, Professor of Mathematics in University College, London.

[Read April 23, 1860.]

IN my second and third papers on logic (Vol. ix. part 1, Vol. x. part 1,) I insisted on the ordinary syllogism being one case, and one case only, of the *composition of relations*. In this fourth paper I enter further on the subject of *relation*, as a branch of logic.

Much has been written on relation in all its psychological aspects except the logical one, that is, the analysis of necessary laws of thought connected with the notion of relation. The logician has hitherto carefully excluded from his science the study of relation in general: he places it among those heterogeneous *categories* which turn the porch of his temple into a magazine of raw material mixed with refuse. Aristotle does not give this part of logic a very hopeful look when (Categories, ch. v. or vii.) he puts forward no better phrase* than *πρός τι* to denote his abstract idea of relation. And such hope as there is becomes well-nigh extinct when we learn that the rudder is not properly the rudder of the ship, because people do not say (*οὐ λέγεται*) that the ship is the ship of the rudder. Here, as occasionally elsewhere, Aristotle is rather too much the expositor of common language, too little the expositor of common thought. Surely the question, 'What ship does this rudder belong to?' must sometimes have been heard in an Athenian dockyard: and if this question were not equivalent to 'Which is the ship of this rudder?' in the common idiom, the equivalence ought to have been established by the logician so soon as wanted. Terms may be related, even though they have more meaning than just goes to the relation. A ship is 'the steered' and the rudder is 'the steerer:' that it happens to a *ship* to mean *more* than 'a thing steered,' and to a *rudder* to mean *no* more than 'the thing which steers,' is a purely material concomitant of the words.

The logicians of our day seem to my mind to combine a want of memory by which

* When a noun is thus formed, it is a sign that the mind of the language has not possession of the idea. There is a useful piece of furniture called a *what-not*, a holder of miscellaneous articles: the word is of the same type as *πρός τι*. We are an orderly people, and the notion of unarranged deposit is not among those for which we find words of serious approval. Dr Roget can produce no nouns which come close to the point

except the contemptuous term *medley*, the corruption of a legal term *hodgepodge*, also contemptuous out of law, and the best word of all, the only one which perfectly applies, *omnium gatherum*, contemptuous and not English. The applier of the term *what-not* probably was not aware that he had the authority of Aristotle for his mode of proceeding.

they do their own literary ancestors less than justice with an assumption by which they take advantage of their own wrong. Their predecessors worked the modern languages into adequate vehicles of scientific thought. They greatly augmented what they found in the Latin of the power of the Greek: and the vernacular idioms, partly by abstraction and partly by imitation, acquired the increased power of the Latin. From the first growth of experimental science down to our own day the logicians have not shewn themselves aware of this: at least they have not known how to use it in efficient defence of 'the schoolman' from the sneers of the physical writers. A person who approaches mediæval psychology fresh from a long course of thought on exact science, its language, its progress, and its impediments, finds the claim of the scholastic writers presented to him in a strong light. He seeks the old books to learn something about the 'trammels'—this is, I believe, the proper technical word—in which they bound the human mind: for the human mind, he has been implicitly instructed, is rapid and vigorous in abstract science, if only it take care to follow no leader. But he finds that very much of his own lingual power of expressing abstract thought is due to the action of these schoolmen upon his mother-tongue: he feels that he is at the fountain-head of his own scientific idiom: he learns that those who raised the seed have been ignorant enough to think lightly of those who dug and manured the ground: and he comes to know that *language capable of science* can only be the result of deep thought upon the mind in relation to words, and words in relation to things. He then remembers the sarcasm* of the spider, and finds it a true description of a needful process: the web first, the fly afterwards.

The logician appeals to common thought in proof of his system being an exposition of the necessary laws of thought. In one sense he is right: his system contains the *necessary* laws of thought; for the actual thought of the lowest type of mankind must be the maximum of the *necessary* thought: so that, on the Ricardo theory, the logician has created a great deal of rent. But, meaning by a necessary law of thought that mode of action which must guide the thinker who comes up to the point at which the question of law or no law can arise, I affirm that all the difference between Aristotle or Occam and the lowest of the noble savages who ran wild in the woods is only part, and I believe a very small part, of the development of human power. If the logician could leaven his own mind with a full sense of what his foregoers did for thought and for language, a spontaneous

* *Logicus araneæ potest comparari,
Quæ subtiles didicit telas operari,
Quæ suis visceribus volunt consummari,
Est pretium musca—si forte queat laqueari.*

When Bacon adopted this sarcasm, he left out the fly, and propounded the web as the end, not the means: and he has been followed by some original writers who have likened the schoolman to the spider, which spins all its own *nourishment* from its own bowels.

The web which caught the flies at last was a mathematical web: and in time an imitation of the mathematical web was applied to subjects over which the empire of pure calculation did not extend. Neither the mediæval logicians nor the followers of Bacon ever constructed a physical science. Those who delight to call themselves the followers of Bacon are in

reality followers of Galileo and of Newton—of Galileo, the predecessor of Bacon in his works, and of Newton, who cannot be *proved* to have known that there was such a person as Bacon. Again and again has it been asked *what discovery has ever been made by that method which Bacon recommended?* and always without answer. And for this reason, that the mythical Bacon cannot be supported by quotations from the *Novum Organum*. It is full time that those who actually read the great work—for such it really is—which is supposed to have taught experimental philosophy her rudiments, should either support the pretensions advanced in its favour, or aid in the substitution of others of a more correct character. Provided always that *Bacon's own method*—which is very easily propounded—be advanced in *Bacon's own words*.

admission would grow that if these same foregoers had worked themselves into the same familiarity with relation in general which they obtained with what I call *onymatic* relations, and still more if they had cultivated those yet wider fields which lie beyond, the common language would have now possessed facilities on the want of which* he founds his assertion of the sufficiency of the old logic. Though satisfied that the educated world is in advance of the current system of logic, I feel equally sure that a more extensive system would work a still greater progress.

The investigation of the subject of relation has kept before my thoughts, and with a *de te fabula narratur* of a most humiliating character, conclusions which instruction of young minds during more than thirty years has forced upon me. A person accustomed to teach mathematics from the earliest commencement to the highest theories, to pupils wholly unformed in inference upon matter with which they are not familiar, has a perception of the difficulties of the uneducated process of reasoning which few others can arrive at. And that which he cannot help seeing in the efforts of an unformed mind, decided in character and large in amount, he learns to detect in the more advanced student and in the educated man. At the same time he finds the reason why the deficiency need not be acknowledged, and may even be denied by any one who takes the proper ground. For it is not a deficiency which strikingly manifests itself in habitual faults of commission: habitual faults are only in habitual things. The evil is most patent when new and strange materials are submitted to the mind; and it bears fruit, though of course undetected by positive consequences, in the many cases in which want of power is a prohibition.

The uncultivated reason proceeds by a process almost† entirely material. Though the necessary law of thought must determine the conclusion of the plough-boy as much as that of Aristotle himself, the plough-boy's conclusion will only be tolerably sure when the matter of it is such as comes within his usual cognizance. He knows that geese being all birds does not make all birds geese, but mainly because there are ducks, chickens, partridges, &c. A

* An existing instrument always appeals to the fact—in justice I must say the established fact—that all which ever was done resulted from the use of then existing instruments. In our own day Brown Bess has asked the long range rifle how many battles she won in the Peninsula: to which the rifle has replied by asking Brown Bess how many battles *she* won forty years before she was invented.

† The syllogism is complex, and so is the act of walking: but in both cases the mind produces the whole without a consciousness of parts. Several persons have thought I was carrying things too far when, in my first paper, I said that a person who calls out *John!* enunciates two propositions, "John is the person I want," and, "You are John." They will probably think that the author cited by Roger Bacon (*Opus Tertium*, p. 102) also went too far, in the following passage. "Auctor Perspectivæ ponit exemplum de puero qui cum ei offeruntur duo poma, quorum unum est pulchrius altero, ipse eligit pulchrius, et non nisi quia judicat pulchrius esse melius, et quod est melius est magis eligendum. Ergo de necessitate puer arguit sic apud se: quod est pulchrius est melius, et quod est melius est magis eligendum; ergo pomum

pulchrius est magis eligendum.... Unde licet laici non habeant vocabula logicæ quibus clerici utuntur, tamen habent suos modos solvendi omne argumentum falsum. Et ideo vocabula sola logicorum deficiunt laicis, non ipsa scientia logicæ."

It is very difficult to deny that both the premises and the conclusion are truly parts of the boy's mental act of choice: but quite impossible to admit that they are *separate* parts. We must distinguish between the compound act of the uneducated thinker, and the analysed compound of the logician; between the process guided by law, and the cognizance of the law which guides. It is not true that the law by which thought is governed must be part of the thought which is governed: though some writers against logic have spoken as if they would sanction the affirmative. And, similarly, some writers against gravitation are hardly intelligible except when taken as implying that Newton gave the particles of matter some mysterious cognizance of $m:r^2$.

It is also clear that the opinion of Roger Bacon's time tended to the conclusion that logic is a science of invented laws, not an analysis of the actual laws of thinking; the mistake is not yet defunct.

beginner in geometry*, when asked what follows from 'Every A is B,' answers 'Every B is A, of course.' That is, the necessary laws of thought, except in minds which have examined their tools, are not very sure to work correct conclusions except upon familiar matter. And above all, *relation* is a difficulty when the related terms are unusual names, even in the most† common cases.

As the cultivation of the individual increases, the laws of thought which are of most usual application are applied to familiar matter with tolerable safety. But difficulty and risk of error make a new appearance with a new subject; and this, in most cases, until new subjects are familiar things, unusual matter common, untried nomenclature habitual; that is, until it is a habit to be occupied upon a novelty. It is observed that many persons reason well in some things, and badly in others; and this is attributed to the consequences of employing the mind too much upon one or another subject. But those who know the truth of the preceding remarks will not be to seek for what is often, perhaps most often, the true reason.

Waiving all question about common matter being usually the subject of tolerably good inference, about the assertion that logic, though of some use, does not fully repay its labour, and about the observed fact—the like of which is true in regard to all studies—that learners of logic not infrequently reason no better after instruction than before,—*waiving* these things, not *admitting* them, I maintain that logic tends to make the power of reason over the unusual and unfamiliar more nearly equal to the power over the usual and familiar than it would otherwise be. The second is increased; but the first is almost created.

An attempt to investigate the forms of thought involved in combination of relations, the results of which are contained in the following pages, has given me personal experience of the truth of the preceding remarks. I have had to work my way through transformations as new to my own mind, so far as the separation of form is concerned, as the common moods of syllogism to a beginner in logic. If there be any person who can see at a glance, and with justifiable confidence, what classes of men, including women, are specified in 'the non-ancestors of all non-descendants of Z,' I should not like to submit to his criticism the confusions and blunders through which I arrived at the following results: unless indeed I were able to remind him of some of his own similar experiences. And this could be done with the greatest names in the history of abstract speculation.

* He is thrown at once into forms of strict reasoning, with unusual matter on which to employ them. Either some logic ought to precede Geometry, with familiar instances; or some acquaintance with figure by measurement ought to precede the reasoning; or, better than either, both.

† Though I take the following only from a newspaper, yet I feel confident it really happened: there is the truth of nature about it, and the enormity of the case is not incredible to those who have taught beginners in reasoning. The scene is a ragged school. TEACHER. Now, boys, Shem, Ham, and Japheth were Noah's sons; who was the father of Shem, Ham, and Japheth? No answer. TEACHER. Boys, you

know Mr Smith, the carpenter, opposite; has he any sons? BOYS. Oh! yes, Sir! there's Bill and Ben. TEACHER. And who is the father of Bill and Ben Smith? BOYS. Why, Mr Smith, to be sure. TEACHER. Well, then, once more, Shem, Ham, and Japheth were Noah's sons; who was the father of Shem, Ham, and Japheth? A long pause; at last a boy, indignant at what he thought the attempted trick, cried out, *It couldn't have been Mr Smith!* These boys had never converted the relation of father and son, except under the material aid of a common surname: if Shem Arkwright, &c., had been described as the sons of Noah Arkwright, part of the difficulty, not all, would have been removed.

If Newton were the examiner of my failures, I could recall the occasion on which he lost his own connexion between the inverse square and the ellipse, because his casual diagram put conjugate diameters at right angles to one another, and seduced him into the belief that they were the principal axes. Were it Wallis, I could revive the time when he hesitated at $\sqrt{12} = 2\sqrt{3}$, sure of the theorem, but doubtful of the validity of the expression, for want of precedent. Were it Leibnitz, I could bring to his memory the co-inventor of the differential calculus, doubting whether to say yes or no to the equation $\frac{dy}{dx} = d\left(\frac{y}{x}\right)$, and working out the decision on paper. And so on.

The want of power which most persons feel in the treatment of combined relations, may be well illustrated by cases of the class of relationships which have almost appropriated the name, those of consanguinity and affinity. Many educated persons, and some acute logicians, would either pause for an unreasonable time, or would not give the right answer, if asked for *all* the conclusion* that follows about John and Thomas from 'William is not John's father, and Thomas is William's uncle.'

The only relations admitted into logic, down to the present time, are those which can be signified by *is* and denied by *is not*. Allowing to the substantive verb all its range of meaning—and that range is a wide one—and introducing *contrary* notions, all the relations which were styled *onymatic* in my last paper, whether arithmetical, mathematical, or metaphysical, are capable of inclusion. All other relation is avoided by the dictum that it shall be of the form of thought to consider the relation and the related predicate as *the* predicate, and the judgment as a declaration or denial of identity between this and the related subject.

Accordingly, all logical relation is affirmed to be reducible to *identity*, A is A, to *non-contradiction*, Nothing both A and not-A, and to *excluded middle*, Everything either A or not-A. These three principles, it is affirmed, dictate all the forms of inference, and evolve all the canons of syllogism. I am not prepared to deny the truth of either of these propositions, at least when A is not self-contradictory, but I cannot see how, alone, they are competent to the functions assigned. I see that they distinguish truth from falsehood: but I do not see that they, again alone, either distinguish or evolve one truth from another. Every transgression of these laws is an invalid inference: every valid inference is not a transgression of these laws. But I cannot admit that every thing which is not a transgression of these laws is a valid inference. And I cannot make out how just the only propositions which are true of all things conceivable can *be* or *lead to* any distinction between one thing and another. I believe these three principles to be of the soil, and not of the seed, though the seed may

* The old riddle-books often propound the following query:—If Dick's father be Tom's son, what relation is Dick to Tom? When a boy, I heard the following classical and Protestant version of the puzzle, over which I have since made grown persons ponder, not always with success. An abbess observed that an elderly nun was often visited by a young gentleman, and asked what relation he was. "A very near relation," answered the nun; "his mother was my mother's

only child:" which answer, as was intended, satisfied the abbess that the visitor must be within the unprohibited degrees, without giving precise information. When this is proposed, the first answer often is, He was her grandchild; and if the story did not say that the visitor was young, he would sometimes be taken for her grandfather; the matter not preventing, $\phi\phi^{-1}$ might as well be mistaken into $\phi^{-1}\phi^{-1}$ as into $\phi\phi$.

possess some materials of the soil; of the foundation, not of the building, though the bricks may partake of the nature of the foundation; of the rails, not of the locomotive, though both may have iron in their structure.

The canons of ordinary syllogism cannot be established without help from our knowledge of the *convertible* and *transitive* character of identification: that is, we must know and use the properties 'A is B gives B is A' and 'A is B and B is C, compounded, give A is C.' Can these principles be established by concession of 'A is A, nothing is both A and not-A, and every thing is one or the other'? All my attempts at such establishment end in begging* the question, when closely scrutinised. The logicians do not make their deduction in perfectly precise and formal method, so that a lapse may be clearly pointed out. I suspect that the use of convertibility and transitivity actually takes place, and must take place, in every attempt to deduce the legitimacy of the two laws, as necessary consequences of the three laws: and if my suspicion be correct, it follows that the *two* principles must be assumed independently of the *three*. I cannot argue the question until I find some more precise attempt to maintain the assertion: I suspect that 'it is *as plain as that* A is A' has been confounded with 'it is true *because* A is A.'

In the consideration of the proposition, *identification of objects* is in truth a *relation of concepts*. In the ordinary books on logic, the relation before the mind is confusedly mixed up with the *judgment*, the assertion or denial of the relation. The word *is* has two different meanings: standing alone, it means *identity affirmed*; in the phrase *is not*, it means only *identity*. I claim to recognise the distinction between relation and judgment, and to assign to each notion its own symbol. Let X and Y be terms, and L a relation in which X may or may not stand to Y, let X..LY signify the assertion of the relation, and X.LY its denial. This separation of relation and judgment is an important step towards the treatment of syllogistic inference as an act of combination of relation; as also towards the knowledge that the ordinary canons of syllogism do actually embrace *every* case in which one relation only is used, and that relation transitive and convertible.

That all analysis of thought should be confined to expression under one class of relations is the defence of a system formed under limited views, and a defence which nothing but necessity could have originated. It is the *great principle of pebbles* invented for justification of arithmeticians who have never got beyond pebbles. Pure arithmetic, dealing with nothing but the notion of number, has all its processes reducible of course to making number more or less. The solution of a cubic† equation to 153 figures is within the reach

* It is not lawful to employ syllogism in deducing syllogism from postulates which are affirmed to necessitate it: for if all syllogism be invalid—and whether or no is the question—it may establish *itself* on any basis. The quadrature of the circle may be deduced from the Habeas Corpus Act by a method which contains only one paralogism. I have heard logic called the science which *demonstrates demonstration*: it only *analyses* demonstration. So surely as no system of truths can be established upon no truth to begin with, so surely can no methods of *transition or inference* be established without methods of inference to start with. If then the *very earliest* demand the use of the transitive and convertible

characters of the copula, these characters cannot be themselves inferred: consequently, unless non-inferentially and *immediately* seen in the three principles, they must be adopted on their own security. The moment this is done, the whole of the common syllogism must be admitted under the extension to *every copula which is both transitive and convertible*; for transitivity and convertibility once separated from the three principles of *identification*, and standing on their own footing, the restriction of the copula to the *identifying* verb 'is,' no matter how many its senses, is only arbitrary and lawless distinction.

† "If the curiosity of any gentleman that has leisure" to

of a *calculator* who has enough of *calculi*, life, and patience. And number is defined by the more or less of counting which has taken place in its formation; further counting onwards is the *process* required in addition; counting backwards is the process required in subtraction: and to these all other processes can be reduced. The last unit, or item* of numeration, tells the result of all that has been done. Suppose any one to contend that arithmetic should never transcend pure counting, and he would be a faithful imitator of argument about logic, as not infrequently expressed, and always implicitly maintained. The arithmetician I have supposed should argue from the fundamental character of the counting process: he should leave practice and progress out of sight, should refuse to allow the possibility of abstractions which might end in the differential calculus, and should contend for the pure form of arithmetical thought. Every merchant's clerk would laugh at his book of arithmetic, and would be joined by every speculator on that theory of numbers at which he could never arrive. But our arithmetician should stand firm upon the fact that men naturally count on their fingers. And though those who count on the fingers do not want him, and those who can do better will not have him, he can retire within himself, satisfied that he is the true philosopher of arithmetic, and the sole depository of the science. And, all unreasonable as he is, he would be more reasonable than the logician. For it *is* the truth that all arithmetical result can be obtained by counters: it is *not* the truth that all inference can be obtained by ordinary syllogism, in which the terms of the conclusion must be terms of the premises. If any one will by such syllogism prove that because every man is an animal, therefore every head of a man is a head of an animal, I shall be ready to—set him another question.

When the logician contends that a syllogism which is not onymatic can be reduced to one which is, he always proceeds by a statement of the combination of relations, for his

use Halley's words when inviting to the calculation of the logarithms of all prime numbers under 100,000 to 25 or 30 places of figures, "should prompt him to undertake" to verify this assertion, he ought to find the following as the solution of the celebrated equation $x^3 - 2x - 5 = 0$. I will not say, with Halley, "I can assure him that the facility of this method will invite him thereto."

$x = 3 \cdot 09455 \ 14815 \ 42326 \ 59148 \ 23865 \ 40579 \ 30296 \ 38573 \ 06105$
 62823 91803 04128 52904 53121 89983 48366 71462 67281
 77715 77578 60839 52118 90629 63459 84514 03984 20812
 82370 08437 22349 91

This result, which will place the power of Horner's method in its proper light of evidence, was calculated in 1850 by my pupil Mr John Power Hicks, since of Lincoln College, Oxford, and has not been published till now. A hundred places had previously been calculated by another pupil, Mr William Harris Johnston (*Mathematician*, Vol. III. p. 289) whose solution was unknown to Mr Hicks. Neither solution was merely numerical exercise; both were performed upon a knowledge of, and by incitement of, the tardiness of mathematicians, as well abroad as at home, in recognising the true place of Horner's discovery in *fundamental* arithmetical operation.

* In my last paper I criticised the phraseology of logicians when they say that the difference between one and another individual of the same species is *numerical*. An able defender referred me to the Greek original of the phrase: in

Porphyry, &c., things which, being different, do not differ *είδει*, differ *ἀριθμῶν*. My thorough conviction that the Greeks never altered the vernacular in scientific terms led me to an examination of the word *ἀριθμός*, the results of which appear in the *Transactions of the Philological Society* for 1859. The original meaning of *ἀριθμός*, never lost, though soon associated with the secondary sense of *total*, is the *item* of enumeration, the unit of a collection, which standing alone would be *μονάς*. Thus Aristotle, (*Metaphysics*, book xi. or xii.) speaking of the primary meaning, affirms that *μονάς* and *ἀριθμός* do not differ in *quantity*. When an *ἀριθμός* was spoken of as large, the departure from the original meaning is precisely that which takes place in our own language when a sale is said to be made at a *high figure*, meaning much money to count. The word *sum* gives occasion to similar remarks. *Summa* and *sum* meant number indicated by the *highest unit* of counting: neither had reference to addition more than to subtraction, number to be subtracted being also *sum* and *summa deducibilis*. The *totum* was *summa totalis*, and *sum total* still remains in use, sounding like tautology: but the fact is that *totalis*, when it dropped off, left its meaning fixed in *summa*. The school-word for arithmetic, *summing*, is not a derivation from the leading rule, *addition*, but means, or meant, numbering generally. Logicians would speak more to the purpose, in English, if they substituted *monadical* for *numerical*: nothing can make a numerical difference to an English ear except a difference of numerical quantity.

major, and an assertion that the relations so introduced into his *principium* exist in the *exemplum* before him, for his minor. But though this evasion—it is nothing else—is practised, and serves to hide the insufficiency of the onymatic syllogism, it is not distinctly proclaimed, and universally applied. When I first challenged the reduction to an Aristotelian syllogism of the inference that *some* must have both coats and waistcoats if *most* have coats and *most* have waistcoats, I supposed that among the attempts to answer would be the following:—‘Two terms each of which has more than half the extent of a third term are terms which have some common extent; the men who have coats and the men who have waistcoats are two terms each of which has more than half the extent of a third term; therefore the men who have coats and the men who have waistcoats are terms which have some common extent.’ But this was not brought forward: though it had as much right to appear as the following. Reid denied that ‘ $A = B, B = C, \therefore A = C$ ’ is a (common) syllogism. True, says one able expounder, because it is *elliptical*: true, says another, because it is *material*. Both render it into what they call true logical form as follows:—Things equal to the same are things equal to one another; A and B are things equal to the same; therefore A and B are things equal to one another. I pass over the assertion that $A = B \&c.$ is an *ellipsis* of this last, as not worth answer: the imputed *material* character requires further consideration.

When it shall be clearly pointed out, by definite precept and sufficiently copious example, what the logicians really mean by the distinction of form and matter, I may be able to deal with the question more definitely than I can do at this time. Dr Thomson (*Outlines, &c.*, § 15) remarks that they seldom or never talk much about the distinction without * confusion. I can but ask what is that notion of form as opposed to matter on which it can be denied that ‘ $A = B, B = C, \therefore A = C$ ’ is as pure a form of thought, apart from matter, as ‘*A is B, B is C, \therefore A is C.*’ In both there is matter implied in A, B, C: but in both this matter is vague, all that is definite being the sameness of the matter of A, &c. in all places in which the symbol occurs. In both there is a law of thought appealed to on primary subjective testimony of consciousness; ‘equal of equal is equal’ in the first; ‘identical of identical is identical’ in the second. These two laws are equally necessary, equally self-evident, equally incapable of demonstration out of more simple elements. Does

* Because there really is not *much* to talk about: the separation is soon conceived, and soon made; and the work begins when, after separation, the analysis of the things separated is attempted. There is much detail in cookery, much in shoemaking, if we start from the raw flesh and the raw hide. The separation of these parts of the animal is easily seen to be wanted and easily made; any very great talk about it can have no effect, unless it be to give a chance of leather steaks and beef shoes. One of the oldest of the schoolmen, John of Salisbury—whose date may be remembered by the record that *tacitus, sed mœrens, continuo se subduxit*, when Thomas-a-Becket was killed by his side—says nearly as much as need be said, as follows:—“At qui lineam, aut superficiem attendit sine corpore, formam utique contemplationis oculo a materia dejungit: cum tamen sine materia forma esse non possit. Non tamen formam sine materia esse abstrahens hic concipit

intellectus (compositus enim esset) sed simpliciter alterum sine altero, cum tamen sine altero esse non possit, intuetur. Nec hoc quidem simplicitati ejus præjudicat, sed eo simplicior est, quo simpliciora, sine aliorum admixtione, perspicit singulatim. Hoc autem naturæ rerum non adversatur, quæ ad sui investigationem hanc potestatem contulit intellectui, ut possit conjuncta disjungere, et desjuncta conjungere.” (*Metaphysics*, Lib. II. cap. 20). Add to this illustration from the original meaning of the terms the extension of the words *matter* and *form* to any distinction between the *quod se habet* and the *modus se habendi*, as also to the distinction of *operation* and *operated on*, and the two words may then take leave of each other. But when form and matter are to be adapted to the defence of the existing mode of distinction, it is no wonder if they must be hammered until the anvil is hot.

the very notion of *equation* demand the identity of A and A to be conceded? just as much does the very notion of identification demand the *equality* of A and A to be conceded. We can think of nothing but what has some attributes which have quantity: and the very notion of identity, demanding identity of all attributes, demands equality of quantity in those which *have* quantity. On what definition, then, of form is 'equal of equal is equal' declared material, while 'identical of identical is identical' is declared formal?

In choosing the instance of *equality*, a very near relation of *identity*, I am rendering but a poor account of my own thesis. I maintain that there is no purely and entirely *formal* proposition except this:—'There is the probability α that X is in the relation L to Y.' Accordingly, I hold that the copula is as much materialised, when for L we read *identity*, as when for L we read *grandfather*. The mere notion of *materiality*, like that of quantity (see my last paper), *non suscipit magis et minus*. And I hold the supreme *form* of syllogism of one middle term to be as follows;—There is the probability α that X is in relation L to Y; there is the probability β that Y is in relation M to Z; whence there is the probability $\alpha\beta$ that X has been proved in these premises to be in relation L of M to Z. Here is nothing but *formal* representation, that is, expression of form without particular specification of matter. I now proceed to something of a less controversial character.

Any two objects of thought brought together by the mind, and thought together in one act of thought, are *in relation*. Should any one deny this by producing two notions of which he defies me to state the relation, I tell him that he has stated it himself: he has made me think the notions in the relation of *alleged impossibility of relation*; and has made his own objection commit suicide. Two thoughts cannot be brought together in thought except by a thought: which last thought contains their *relation*.

All our prepositions express relation, and indeed all our junctions of words: but the preposition *of* is the only word of which we can say that it is, or may be made, a part of the expression of every relation; though the same thing may nearly be said of the preposition *to*. When relation creates a *noun substantive*, *of* is unavoidable: if A by its relation to B be C, it is a C of B. A volume might be written on the idiom of relation: but it would be of the matter, not of the form, of the subject. I add a few desultory remarks, because some readers would hardly, from the symbols themselves, form a notion of the wide extent of thought which the symbols embrace.

When two notions are components in one compound, as *white* and *ball* in the phrase *white ball*, we have one of the many cases in which the relation is not made prominent, and the compound, as a whole, is the notion on which thought fixes. So little is the relation thought of that its introduction may produce unusual idioms. In speaking of the appurtenance of *white* to *ball*, we have the *whiteness of the ball*, which is idiomatic: but in speaking of the appurtenance of the *ball* to the *white*, we have the *rotundity of the white*, which is not familiar, though intelligible. Here we are sensible of a difficulty which usage puts in the way of logic: language hesitates at *realising* notions which are not objectively called *things*. The metaphysical distinction of the ball being a substance, of which the whiteness is an inherent accident, is extralogical: all we have to do with is the junction in one notion of matter, roundness, and whiteness. Whether whiteness and

rotundity were given to matter, or material and whiteness to rotundity, is of no account: the turner can do only the first, the thinker can do either. The notion of metaphysical or physical *order of precedence* in the entrance of components, dictates the exclusion of forms of language which are necessary to logical precision. We may think of a *horse*, and then of the attributes *swift* or *slow*: we speak of the *speed of the horse*, correctly expressing what we have in thought as related by appurtenance to the animal. But we never *speak of the horseness of the speed*: do we ever *think* of it? Suppose a horse going a hundred miles an hour: such a thing was never known. Suppose one which goes a million of miles in a second: perhaps this is the first time such a thing was ever *heard of*. In the first case the speed attributed to the horse is no marvel: in the second case it is not in nature, that we know of. We object to both rates, as predicated of a horse: but to the first rate *only* as so predicated. That is, it is not the velocity of the horse, but the *equinity of the velocity*, that strikes us as unprecedented when we speak of a hundred miles an hour: and the logician may use his privilege of making language for every distinction which exists in thought.

Relations of appurtenance, and indeed all others, carry with them distinctions of which grammar takes no cognizance: they give *time* or *tense*, for example, to nouns. That which hangs in the butcher's shop under the name of a *calf's head*, hangs under that name with perfect propriety: but the noun has a past tense. I am not sure that we should have been so well off as we are if philosophers had invented our language: it may have been that in such a case we should have had less sense and no poetry: but assuredly our nouns would have had moods indicative and potential, as well as tenses, past, present and future.

The relation in a compound notion sometimes seeks emergence; and the word *of* demands entrance. When we hear that 'it was the most bloody battle,' we feel an unfinished sentence: what of? the Peloponnesian war? the Peninsular war? &c. If not one of these a separation is wanted which may throw into notice the relation of appurtenance; 'it was the most bloody *of* battles.'

Indefinite extension of one component is a bar to the conception of relation, and tends to fix thought upon the whole compound. Thus in *six sheep*, the relation of *six* to *sheep* is almost dormant, so long as the selective and separative force of *six* is applied to all possible sheep. Make the collection more definite, and the relation demands expression: *six of* the sheep, *six of* his sheep. Not that *six of sheep* is unintelligible: and, on the other hand, *six his sheep* is a form not unknown in old English. Largeness of selection, totality, has the effect of destroying the relating preposition: thus *all his sons* is as admissible as *all of his sons*. But let the expression of completeness be retarded ever so little, and the relating preposition demands entrance. We do not say 'All *of* men are animals:' but we do say, 'Of men, all are animals.' The habits of thought of a nation silently accomplish many changes which we call caprices of language. Our modern forms of thought tend to sharpen specification of relation, especially in distinguishing agency from other relations. We no more hear of a person forsaken *of* his friends; it is now always *by*. Neither does the active participle bear the expression of relation, except as a vulgarism: squires and hounds are no longer catching *of* foxes.

now proceed to consider the formal laws of relation, so far as is necessary for the treatment of the syllogism. Let the names X, Y, Z, be singular: not only will this be sufficient when *class* is considered as a unit, but it will be easy to extend conclusions to quantified propositions. I do not use the mathematical symbols of functional relation, ϕ , ψ , &c.: there are more reasons than one why mathematical examples are not well suited for illustration. The most apposite instances are taken from the relations between human beings: among which the *relations* which have almost monopolized the name, those of consanguinity and affinity, are conspicuously convenient, as being in daily use.

Just as in ordinary logic *existence* is implicitly predicated for all the terms, so in this subject every relation employed will be considered as actually connecting the terms of which it is predicated. Let X..LY signify that X is some one of the objects of thought which stand to Y in the relation L, or is one of the Ls of Y. Let X.LY signify that X is not any one of the Ls of Y. Here X and Y are *subject* and *predicate*: these names having reference to the mode of entrance in the relation, not to order of mention. Thus Y is the predicate in LY.X, as well as in X.LY.

When the predicate is itself the subject of a relation, there may* be a composition: thus if X..L(MY), if X be one of the Ls of one of the Ms of Y, we may think of X as an 'L of M' of Y, expressed by X..(LM)Y, or simply by X..LMY. A wider treatment of the subject would make it necessary to effect a symbolic distinction between 'X is not any L of any M of Y' and 'X is not any L of some of the Ms of Y.' For my present purpose this is not necessary: so that X.LMY may denote the first of the two. Neither do I at present find it necessary to use relations which are aggregates of other relations: as in X..(L,M)Y, X is either one of the Ls of Y or one of the Ms, or both.

We cannot proceed further without attention to forms in which *universal* quantity is an inherent part of the compound relation, as belonging to the notion of the relation itself, intelligible in the compound, unintelligible in the separated component.

First, let LM' signify† an L of *every* M, LM'X being an individual in the same relation to many. Here the accent is a sign of universal quantity which forms part of the description of the relation: LM' is not an aggregate of cases of LM. Next let L,M signify an L of an M in every way in which it is an L at all: an L of none but Ms. Here the accent is also a sign of universal quantity: and logic seems to dictate to grammar that this should be read 'an every-L of M.' The dictation however is of

* A mathematician may raise a moment's question as to whether L and M are properly said to be *compounded* in the sense in which X and Y are said to be compounded in the term XY. In the phrase *brother of parent*, are *brother* and *parent* compounded in the same manner as *white* and *ball* in the term *white ball*. I hold the affirmative, so far as concerns the distinction between *composition* and *aggregation*: not denying the essential distinction between *relation* and *attribute*. According to the conceptions by which *man* and *brute* are aggregated in *animal*, while *animal* and *reason* are compounded in *man*, one primary feature of the distinction is that an impossible component puts the compound out of existence, an impossible aggregate does not put the aggregate out of

existence. In this particular the compound relation 'L of M' classes with the compound term 'both X and Y.'

† Simple as the connexion with the rest of what I now proceed to may appear, it was long before the *quantified relation* suggested itself, and until this suggestion arrived, all my efforts to make a scheme of syllogism were wholly unsuccessful. The quantity was in my mind, but not *carried to the account of relation*. Thus LX))MY, or every L of X is an M of Y, has the notion of universal quantity attached in the common way to LX, not to L: its equivalents X..L⁻¹MY, and Y..M⁻¹L/X, shew X and Y as singular terms, and though expressing the same ideas of quantity as LX))MY, throw the quantity entirely into the description of the relations.

convenience; not of obligation, as in the case of the double negative. Either some horse or no horse; if not no horse, then some horse. The Greek* idiom refused this dilemma: There is no scrape that man does not get into: if we had no other way of knowing this, we have the assurance of Euripides; but he informs us that there is *not* no scrape that man does not get into. The *educated* English idiom follows logic, which here commands. Such a phrase as the 'every uncle of a sailor' has no meaning except in poetry, where it means the *sole* uncle. It would be highly convenient if the distinction between LM' and L,M could be made as in 'L of every M' and 'every-L of M.'

The symbols $L'MX$ and LM,X , which I shall not need, analogically interpreted would mean 'every L of an M of X' and 'an L of an M of none but X.' The compound symbol $L,M'X$ means an L of every M of X and of nothing else; and is really the compound $(LM'X)$ (L,MX). No further notice will be taken of it.

We have thus three symbols of compound relation; LM , an L of an M; LM' , an L of every M; L,M , an L of none but Ms. No other compounds will be needed in syllogism, until the premises themselves contain compound relations.

In *every* case in which there is a first and a second, let the *first* be *minor*, the *second*, *major*. Thus if $X..LMY$, let X and Y be its minor and major terms, and L and M its minor and major relations: if it be the *first* premise of a syllogism let it be the *minor* premise.

The *converse* relation of L, L^{-1} , is defined as usual: if $X..LY$, $Y..L^{-1}X$: if X be one of the Ls of Y, Y is one of the L^{-1} s of X. And $L^{-1}X$ may be read '*L*-verse of X.' Those who dislike the mathematical symbol in L^{-1} might write L^v . This language would be very convenient in mathematics: $\phi^{-1}x$ might be the '*\phi*-verse of x ,' read as '*\phi*-verse x .'

Relations are assumed to exist between any two terms whatsoever. If X be not any L of Y, X is to Y in some not-L relation: let this *contrary* relation be signified† by l ; thus $X..LY$ gives and is given by $X..lY$. Contrary relations may be compounded, though contrary terms cannot: Xx , both X and not-X, is impossible; but Llx , the L of a not-L of X, is conceivable. Thus a man may be the partisan of a non-partisan of X.

Contraries of converses are converses: thus not-L and not- L^{-1} are converses. For $X..LY$ and $Y..L^{-1}X$ are identical; whence $X..not-LY$ and $Y..(not-L^{-1})X$, their simple denials, are identical; whence not-L and not- L^{-1} are converses.

* It would be worth the while of some one who has the requisite scholarship to examine the question how far the negatory power of the double negative in Greek determined the course of Aristotle in regard to privative terms. In further reference to the dictating power of logic, I may observe that it does not go far: forms cannot dictate meaning to any but a very small extent. For instance: It is almost universal, but not quite, that transference of *not* from the copula to the predicate produces no change of meaning. 'He either will do it, or he will-not do it' means the same as 'He either will do it, or he will not-do it;'[†] and the two of each set are alternatives. But 'He either can do it, or he cannot do it' has not identity of meaning with 'He either can do it or he can not-do it:' the first pair are repugnant alternatives, the second are not: the same person who can do it, usually can

not-do it, or can let it alone, but not always. Again, the junction of *not* to the verb usually gives a contrary, or a repugnant alternative: he eats or he eats not, he has or he has not, he does or he does not. But we may not say, Either he must, or he must not; these are no necessary alternatives: we can only say, Either he must, or he need not, Either he must not, or he may. Many similar instances might be given.

† The affirmative symbol ($..$) is derived from the junction of the two negatives $(.)$ $(.)$. Analogy would seem to require that the privative relation not-L should be denoted by $(.L)$. Or thus:—Let W denote the affirmation, and V the denial: then $XWLY$ would denote that X is an L of Y, and $XVVLY$ that X is not a not-L of Y. But I do not at present find advantage in a notation which expresses $X..LY$ and its equivalent $X.lY$ in one symbol: I may possibly do so at a future time.

Converses of contraries are contraries: thus L^{-1} and $(\text{not-}L)^{-1}$ are contraries. For since $X..LY$ and $X..(\text{not-}LY)$ are simple denials of each other, so are their converses $Y..L^{-1}X$ and $Y..(\text{not-}L)^{-1}X$; whence L^{-1} and $(\text{not-}L)^{-1}$ are contraries.

The contrary of a converse is the converse of the contrary: $\text{not-}L^{-1}$ is $(\text{not-}L)^{-1}$. For $X..LY$ is identical with $Y..(\text{not-}L)^{-1}X$ and with $X..(\text{not-}L)Y$, which is also identical with $Y..(\text{not-}L)^{-1}X$. Hence the term *not-L-verse* is unambiguous in meaning, though ambiguous in form.

If a first relation be contained in a second, then the converse of the first is contained in the converse of the second: but the contrary of the *second* in the contrary of the *first*.

The conversion of a compound relation converts both components, and inverts their order. If X be an L of an M of Y , then an M of Y is an L^{-1} of X , and Y is an M^{-1} of an L^{-1} of X . Or $(LM)^{-1}$ is $M^{-1}L^{-1}$. The mark of inherent quantity is also changed in place. If X be* an L of every M of Y , then Y is an M^{-1} of none but L^{-1} s of X . And if X be an L of none but M s of Y , then Y is an M^{-1} of every L^{-1} of X . For $X..LM'Y$ is $MY))L^{-1}X$ or $Y..M^{-1}L^{-1}X$: and $X..LMY$ is $L^{-1}X))MY$ or $Y..M^{-1}L^{-1}X$.

When there is a sign of inherent quantity, if each component be changed into its contrary, and the sign of quantity be shifted from one component to the other, there is no change in the meaning of the symbol. Thus an L of every M is a $\text{not-}L$ of none but $\text{not-}M$ s; and *vice versa*: and an L of none but M s is a $\text{not-}L$ of every $\text{not-}M$; and *vice versa*.

When a compound has no inherent quantity, the contrary is found by taking the contrary of either component, and giving inherent quantity to the other. Thus, either L of an M or $\text{not-}L$ of every M : either L of an M or L of none but $\text{not-}M$ s. But if there be a sign of inherent quantity in one component, the contrary is taken by dropping that sign, and taking the contrary of the other component. Thus, either L of every M or $\text{not-}L$ of an M ; either L of none but M s, or L of a $\text{not-}M$.

The following table contains† all these theorems:

Combination	Converse	Contrary	Converse of contrary Contrary of converse
LM	$M^{-1}L^{-1}$	lM' or L_m	$M^{-1}l^{-1}$ or $m^{-1}L^{-1}$
LM' or l_m	$M^{-1}L^{-1}$ or $m^{-1}l^{-1}$	lM	$M^{-1}l^{-1}$
L_m or lm'	$M^{-1}L^{-1}$ or $m^{-1}l^{-1}$	Lm	$m^{-1}L^{-1}$

* A good instance of the difficulty of abstract propositions: it is easy enough on a concrete instance. If X be the superior of every ancestor of Y , then Y is the descendant of none but inferiors of X .

† The resultant relation in onymatic syllogism is identical with the compound from which it results. Thus $(.)$ is $(.)$, identically: every complement of a deficient is a partient; every partient is a complement of a deficient. The contraries then are identical: and this gives the key to the resulting meaning of quantified compound relations: as $(())$, a genus

of none but species; or $(())'$, a genus of every species. The complete rule of interpretation of such symbols is as follows. Reject as incapable of meaning all cases in which two universals or two particulars have different middle quantities, or in which a universal and particular have the accent upon the particular. Thus there is no such thing as $((Y))'$, or $((Y))'$, or $((Y))'$: a species of every species of a given genus is non-existing. In all other cases, invert the spicula nearest to the accent, erase the middle spicula, and the result shows the relation identical with the given compound. Thus $(.)$ (Y)

If a compound relation be contained in another relation, by the nature of the relations and not by casualty of the predicate, the same may be said when either component is converted, and the contrary of the other component and of the compound change places. That is if, be Z what it may, every L of M of Z be an N of Z , say $LM \)) N$, then $L^{-1}n \)) m$, and $nM^{-1} \)) l$. If $LM \)) N$, then $n \)) lM'$ and $nM^{-1} \)) lM'M^{-1}$. But an l of every M of an M^{-1} of Z must be an l of Z : hence $nM^{-1} \)) l$. Again, if $LM \)) N$, then $n \)) L_m$, whence $L^{-1}n \)) L^{-1}L_m$. But an L^{-1} of an L of none but m s of Z must be an m of Z ; whence $L^{-1}n \)) m$.

I shall call this result theorem K , in remembrance of the office of that letter in Baroko and Bokardo: it is the theorem on which the formation of what I called opponent syllogisms is founded. For example, the combination in one of the mathematical* syllogisms is Every deficient of an external is a coinadequate: *external* and *coinadequate* have *partient* and *complement* for their contraries, and *deficient* has *exient* for its converse: hence every exient of a complement is a partient; which is one of the opponent syllogisms of that first given.

Identity, in theorem K , does not give identity; as will be observed by watching the demonstration. For an instance, *brother of parent* is identical with *uncle*, by mere definition. But *non-uncle of child* is not identical with *non-brother*: for though every non-uncle of child is non-brother (as by the theorem), yet it is not true that every non-brother is non-uncle of child.

If LM be identical with N , meaning that N is an L of an M and of no other signification, we have $LM \parallel N$, $LMM^{-1} \parallel NM^{-1}$, $L^{-1}LM \parallel L^{-1}N$. Now $MM^{-1}X$ and $L^{-1}LX$ are classes which contain X ; so that we may affirm $L \)) NM^{-1}$ and $M \)) L^{-1}N$; but not $L \parallel NM^{-1}$ nor $M \parallel L^{-1}N$.

Having given $LM \parallel N$, it is natural to ask whether we can deduce identical expressions for L and M : the answer is that no such thing can be done. If by M we mean some one particular M left vague, the form of L can be deduced, as we shall see; but not when N is a name for, and only for, every L of every M . Take, for example, the word *uncle*: it is identical with *brother of parent*; either is the other. Can we now construct a definition of *brother* out of *uncle*, *parent*, and their converses. *Uncle of child of X* is no definition of *brother* of X ; it includes the brothers of the other parent. *Uncle of every child of X* will not do, for a similar reason: if X had as many wives as Solomon, and children by all, nothing in logic excludes the supposition that they were all sisters.

In mathematics we have much power of forcing $NM^{-1} \parallel L$ out of $LM \parallel N$ by extension of language: and in a science of truths necessary as to matter it is almost a proof of insufficient grasp when we find either of the forms above unaccompanied by the other. Common

gives $(. ($ or $(($: a complement of every complement is a genus; and *vice versa*. Again, $(. (($ gives $(. ($: a complement of none but genera is an external, &c. Also, $((($ gives $(($: a genus of none but coinadequates is a coinadequate, &c. A defective account of these transformations will be found in my third paper.

* In arithmetical form thus:—Some Y s are not any X s, no Y is Z , therefore some things are neither X s nor Z s. Deny the conclusion, affirm the first premise, and we may deny the second, which gives some Y s are not any X s, everything is either X or Z , therefore some Y s are Z s.

language has some degree of tendency towards the same sort of enlargement of meanings. As in the very example before us: the brothers of the other parent are called *brothers* (in law): and under this extension *uncle of child* is identical with *brother*: for the word *uncle* receives similar extensions.

A relation is said to be *convertible* (though it should rather be said that the subject and predicate are convertible) when it is its own converse; when $X..LY$ gives $Y..LX$. And, L being any relation whatever, LL^{-1} is convertible: but LL^{-1} and L/L^{-1} are each the converse of the other. So far as I can see, every convertible relation can be reduced to the form LL^{-1} . If two notions stand in the same relation to one another, they can always, I think, be made to stand in one and the same relation to some third notion. The converse is certainly true, namely, that two notions which stand in one relation to a third, stand in convertible relation to each other. But it cannot be proved that if $X..LY$ and $Y..LX$, then L must be reducible to MM^{-1} , for some meaning or other of M : this is certainly a *material* proposition. But I can find no case in which material proof fails. Take *identity*, for example: it is the very notion of identity between X and Y that $X..LL^{-1}Y$ for every possible relation L in which X can stand to any third notion. Identification of objects of thought by *names* derives its convertibility from the idea of the names standing in relation of applicability to the same object. Identification in thought of unnamed objects can only be conceived as *convertible* by reference, as above, to other notions. Exclude names, and identify X with itself by 'this is this': it would be absurd to repeat the process, and say that there is conversion by reason of the first *this* of one indication being the second *this* of the other: such conversion would be only the invention of *different names spelt the same way*.

Among the subjects of a convertible relation must usually come the predicate itself, unless it be forced out by express convention. If all convertible relation can be expressed by LL^{-1} this is obviously necessary: for $LL^{-1}X$ includes X . Is a man his own brother? It is commonly not so held: but we cannot make a definition which shall by its own power exclude him, unless under a clause expressly framed for the purpose. Is a brother the son* of the same father and mother with the man himself? Then is he pre-eminently his own brother: for there never lived one of whom we have not more reason to be sure that he was the son of his own father and mother than that any reputed brother had the same parents with him. If we want to exclude him we must stipulate that by brother of X we mean any man who, *not being X himself*, has the same father and mother. In common language the stipulation is or is not made, according to the casual presence or absence of the necessity for it. Put the question what relation to a man is his brother's brother, and most persons will answer, His brother: point out that the answer should be, Either his brother or himself, and

* When the individual is but one among many, and is speaking generally of his class, there is an implication that others are intended, and the introduction of self produces for a moment that sense of incongruity which, if it could be made to last, would give an air of humour. Thus Hobbes, in a sentence which, altering *geometris* into *logicis*, might be said of himself by a person I ought to know, speaks as follows:—

In magno quidem periculo versari video existimationem meam, qui a geometris fere omnibus dissentio. Eorum enim qui de iisdem rebus mecum aliquid ediderunt, aut solus insanio ego aut solus non insanio; tertium enim non est, nisi (quod dicet forte aliquis) insaniamus omnes. Undoubtedly a man is among those who have written on the same subjects with himself.

a fair proportion will think that himself was included. I shall hold, for logical purposes, that the predicate is included among its own convertible relatives.

A relation is *transitive* when a relative of a relative is a relative of the same kind; as symbolised in $LL \)) L$, whence $LLL \)) LL \)) L$; and so on.

A transitive relation has a transitive *converse*, but not necessarily a transitive *contrary*: for $L^{-1}L^{-1}$ is the converse of LL , so that $LL \)) L$ gives $L^{-1}L^{-1} \)) L^{-1}$. From these, by contraposition, and also by theorem K and its contrapositions, we obtain the following results.

L is contained in $LL^{-1}, l, l^{-1}, L, L^{-1}L$	LL is contained in L
L^{-1} $L, L^{-1}, ll^{-1}, l, l^{-1}, L^{-1}L'$	$L^{-1}L^{-1}$ L^{-1}
l ll', L, l	L^{-1}, ll^{-1} l
l^{-1} $L, l^{-1}, l^{-1}L^{-1}$	$ll^{-1}, l^{-1}L$ l^{-1}

I omit demonstration, but to prevent any doubt about correctness of printing I subjoin instances in words: L signifies *ancestor* and L^{-1} *descendant*.

An ancestor is always an ancestor of all descendants, a non-ancestor of none but non-descendants, a non-descendant of all non-ancestors, and a descendant of none but ancestors. A descendant is always an ancestor of none but descendants, a non-ancestor of all non-descendants, a non-descendant of none but non-ancestors, and a descendant of all ancestors. A non-ancestor is always a non-ancestor of all ancestors, and an ancestor of none but non-ancestors. A non-descendant is a descendant of none but non-descendants, and a non-descendant of all descendants. Among non-ancestors are contained all descendants of non-ancestors, and all non-ancestors of descendants. Among non-descendants are contained all ancestors of non-descendants, and all non-descendants of ancestors.

The mathematician forces the predicate itself among its own chain of successive relatives, whether the relation be transitive or not: x , as ϕ^0x , appears in the sequence... $\phi^{-2}x, \phi^{-1}x, \phi^0x, \phi^1x, \phi^2x, \dots$. There is a little tendency towards the same thing in ordinary language, especially when the relation is transitive. Milton, in calling Eve "the fairest of her daughters," meaning female descendants in general, allowed ϕ^0x to be a case of ϕ^2x . Nothing but circumlocution avoids the same thing in our day, and by it language loses much force, or some precision. If we say that Achilles was the strongest of all his enemies, we feel both definite meaning and force: if we say that he was stronger than any one of his enemies, we gain an enfeebling addition of logical accuracy: if that he was stronger than all his enemies, we introduce ambiguity.

I now proceed to the syllogism, taking first the case in which the terms are individual notions, units of thought. All syllogisms of second intention, whether mathematical or metaphysical, come under this case; and arithmetical syllogisms are but aggregates of singular syllogisms, each of which also comes under this case.

The supreme law of syllogism of three terms, the law which governs every possible case, and to which every variety of expression must be brought before inference can be made, is this;—any relation of X to Y compounded with any relation of Y to Z gives a relation of X to Z . This is very nearly the wording of Euclid's implied definition of compound ratio of magnitudes;—The ratio of X to Z is compounded of the ratios of X to Y and

Y to Z. If I had now produced this principle for the first time, and in the present manner, it would surely have been imputed to me that I had made a fanciful definition of syllogism out of a mathematical analogy. But my second paper will bear witness that I enunciated the identity of inference with combination of relation at a time when I had not noted the extreme closeness of the analogy. For when I in that paper remarked that the generality of the notion of composition (of ratio) prevented the Greek geometers from needing to make separate treatment of *decomposition*, I made no allusion (having in truth none to make) to the analogous point of syllogism. But if I *had* generalised the mathematical notion, *from the Greek*, the process would have been both natural and valid. For ratio is no direct translation of λόγος: the Greek* word means *communication*; and the same turn of thought which made λόγος a technical term of geometry made it stand for *any* relation in one of its derived meanings; that is, any way in which we talk about one notion in terms of another. Any way of speaking of one notion with respect to a second, joined with a way of speaking of the second notion with respect to a third, must dictate a way of speaking of the first notion with respect to the third. And this is syllogism: it exhibits, in the most general form, the law of thought which connects two notions by their connexions with a third. The character of the connexions belongs as much to the *matter* of the syllogism as the character of the terms connected.

The universal and all containing form of syllogism is seen in the statement of X..LMZ is the necessary consequence of X..LY and Y..MZ. Whether the compound relation LM be capable of presentation to thought under a form in which the components are lost in the compound—in the same manner, to use Hartley's simile, as the odours of the separate ingredients are not separately perceptible in the smell of the mixture—is entirely a question of matter.

In the Aristotelian syllogism, figure is a function of the *places* of the middle term; and its necessity arises from the nature of the proposition being also a function of the places of its terms: we cannot, in that system, say 'Every X is Y' without having Y for the predicate. Adopt Hamilton's expressed quantifications and, as he justly remarks, figure becomes an unessential variation. Introduce the general idea of relation, and figure resumes its importance: but not as connected with the *place* of the middle term. Whether we say X..LY or LY..X, the figure is the same. Change of figure can be effected only by conversion of relation. The *first* figure is that of *direct transition*: X related to Z through X related to Y and Y related to Z. The *fourth* figure is that of *inverted transition*: X related to Z through Z related to Y and Y related to X. The *second* figure is that of *reference to* (the middle term): X related to Z through X and Z both related to Y. The *third* figure

* Euclid's definition of *ratio*, most properly when most literally translated, is "Communicating instrument is a habitude of two magnitudes of the same kind to one another with respect to *quantuplicity*." We talk about magnitude in terms of magnitude only by *how many times* one contains the other. On the meaning of *πηλικότης* see the *Penny Cyclopædia* and

the *Supplement*, articles *Ratio*. That the communicating instrument was called *communication* (λόγος) was a case of that feature of the Greek under which the *excessive* curve was called *excess* (*hyperbola*), the *defective* curve the *defect* (*ellipse*), the irregular angle the *irregularity* (*anomaly*), and so on. *Parabola* is another instance, of which elsewhere.

is that of *reference from* (the middle term): X related to Z through Y related to both X and Z.

Before generalisation, whatever may be our preference for the first figure, we hardly feel inclined to admit that *inference takes place in no other figure*; that is, *demonstrated* inference: that premises in the second figure can only yield their result by seeing the first figure through the second. Say that X is Y, Z is not Y: how do we know that X is not Z? If X be Y, it is not anything that Y is not: at this point we are immediately aided by 'Y is not Z;,' only mediately by 'Z is not Y.' The ease* of the transformation prevents our feeling that it takes place. But if we take for our premises X..LY and Z..MY, the necessity of conversion of the major premise, that is, of reduction into the first figure, is sufficiently apparent: we cannot express our inference without it.

In my second paper I stated that no inference can be drawn from a negative premise, except by *decomposition* of a relation. This is perfectly true, so long as *contrary* relations and *inherent quantity* are excluded: but not true when they are admitted. The following comparison will illustrate this. Let the premises be X.LY, Z..MY. These premises are identical with X..LY and Y..M⁻¹Z of which all the inference is X..LM⁻¹Z, or either of its two identicals, X.LM⁻¹Z, X.l,m⁻¹Z. Or thus;—X is not any L of Y: of Y we know no more than that it is a *certain* M⁻¹ of Z; and as the M⁻¹ in question is *vagum*—which in English we call *certain*—all we can say is that X is not any L of *all* the M⁻¹s of Z. Hence X.LM⁻¹Z is all the inference we can draw.

Next, let contraries be forbidden. To deduce the inference, without use of inherent quantity or of contraries, we are compelled to proceed by the old *reductio ad impossibile* by which *Baroko* and *Bokardo* were made to listen to reason: and this equally in all cases which contain one negative premise. Let X.LY and Z..MY give X.NZ: then X..NZ and Z..MY, conjointly, must contradict X.LY; that is, X..NMY must contradict X.LY. That is, one instance of NMY must be identical with one instance of LY, the MY in question being Z. Here N is to be determined by the decomposition of a relation, which is all that need be said until we come to the consideration of the forms of inference.

In the mean time I take a concrete instance. Let it be, X is not any uncle of Y, and Z is a parent of Y. The whole inference clearly is that X is not any uncle of a particular child of Z. We also know *which* child: but as we throw away all reference to the middle term—the question being how much can we know when the middle term is completely eliminated—the inference is that X is not the uncle of *all* the children of Z. Material†

* Nothing is so well adapted to exhibit the simplicity of the first figure, as the expression of the four in common language as follows:—

1. X..LY, Y..MZ, X is L of M of Z.
2. X..LY, Z..MY, X is L of that of which the M is Z.
3. Y..LX, Y..MZ, X is that of which the L is the M of Z.
4. Y..LX, Z..MY, X is that of which the L is that of which the M is Z.

Here 'that' and 'the' must be read as indefinites.

† I shall certainly have to meet the old objection that the

correlation of parent and child is not a logical but a material fact. It is undoubtedly material that (parent)⁻¹ is spelt c-h-i-l-d: and the pure *form* of inference, independent of the meanings of u-n-c-l-e and p-a-r-e-n-t, is that X is not any (uncle) (parent)⁻¹ of Z, in which all that is meant by *uncle* and *parent* is that they were the *symbols* we saw in the premises, all the rest of the force of inference being in the meaning of (...) (...) ⁻¹. Again, it is material that 'uncle of all children' is either 'brother,' or 'brother of all wives who have had children:' it is material that the universe of our propositions is strictly moral, so that brothers of paramours of X are not included: it is material that we hope there are no

knowledge, in this instance, converts the conclusion into 'X is neither the brother of Z, nor the brother of *all* the wives who have had children by Z.' Again, let the conclusion be, X is not any N of Z. If then X be N of Z, and Z parent of Y, X must be uncle of Y: that is 'N of parent' is 'uncle,' and N is to be found by decomposition. *What of parent is uncle?* The aggregate of brother and brother-in-law. But to say that X is neither brother nor brother-in-law would be to suppose that Y might be *any* child of Z: so that all we are to say is, X is neither brother, nor brother-in-law with reference to one particular child. Drop the vestige of the middle term, and we say that X is neither brother nor brother-in-law by every wife: which agrees with the preceding.

The mode of decomposition may be thus generalised. Let there be *one* negative premise, and, L and M being the premising relations, let N be the concluding relation denied. Write down the terms of the negative premise, and between them the remaining term, choosing such order as shall make X precede Z. Combine the relations of the two pairs seen, and the combination must be the direct or converted relation in the negative premise, provided that due attention be paid to the particular character in the affirmative premise. For example, let the negative premise be Z.MY. Take Y, Z, and between them write X, YXZ; in which YX, XZ, are seen. Let the affirmative premise be X..LY: then L^{-1} and N combine to give M^{-1} ; or N must be deduced by making $L^{-1}N$ identical with M^{-1} , a certain L^{-1} being understood.

I have had occasion to notice the manner in which, by wilful renunciation of knowledge, the conclusion is made to express not quite all the possible inference. This happens also in the common syllogism. If from 'Some Xs are not Ys' and 'Everything is either Y or Z,' we deduce 'Some Xs are Zs' it is not true that this conclusion embraces the whole knowledge which the premises give. It is known that 'some Xs' mean all that are not Ys: the vague quantity is not so vague as it would be if the conclusion were the only thing known. It ought to be noticed that a universal (Hamilton's *definite* would be a better word) lurks in the conclusion of every particular syllogism: in the above X () Z would be Xy)) Z, if all that is known were expressed. The particular conclusion of a syllogism is the universal of a narrower name: one premise predicates *existence* for a new and compounded name: the conclusion substitutes that compound in the other premise in a legitimate manner.

Reserving the word *mood* as irrevocably associated with details of quantity and quality combined, let each figure have four *phases*, determined by the quality only of the premises. The four phases, + meaning affirmative, and - meaning negative, are to be remembered* in the standard order

+ + - + + - - -

such persons: it is material that if Z be either Whiston or Dr Primrose, the brother of *the* wife would be sufficient. All this and more is conceded: matter makes its appearance the moment L and M mean more than 'certain relations which, and no others, are designated by these letters throughout the syllogism.' Again, when I am told that *Logic* does not provide the inference that 'Philip was Alexander's father' because 'Alexander was Philip's son,' and that it is our *material* knowledge of the relation of father and son that enables us to make the inference, I reply that it is certainly material that father and son are related in the manner of L and

L^{-1} ; but that the transition from X..LY to Y.. $L^{-1}X$ is a *form* of thought, and a more general form than any case of conversion admitted by the logician in the common syllogism. It is that which is *common* to the transitions 'X a genus of Y, therefore Y a species of X', 'X a parent of Y, therefore Y a child of X', 'X an identical of Y, therefore Y an identical of X,' &c.: and is therefore more abstract than any of them, and equally *form without matter* to all of them.

* Some persons, of whom I am one, but whether it be a gift or a defect I do not know, cannot associate two things with two other things, each with each, merely by conventional

Let these be the *primary* phases of the four figures. The order of the phases, in the four figures, is determined by reading *from* the leading or primary phase, first backwards and then forwards. Thus the phases are as follows:

	1	2	3	4
Figure I.	++	-+	+-	--
II.	-+	++	+-	--
III.	+-	-+	++	--
IV.	--	+-	-+	++

The following is the table of forms of syllogism, afterwards explained.

	1	2	3	4	
I	X. LY	X. LY	X. LY	X. LY	I
	Y. MZ	Y. MZ	Y. MZ	Y. MZ	
	X. LMZ	X. LMZ	X. LmZ	X. lmZ	
	X. lM'Z	X. lM'Z	X. lm'Z	X. Lm'Z	
	X. L,mZ	X. l,mZ	X. L,MZ	X. l,MZ	
	LM N	NM ⁻¹ L	L ⁻¹ N M	lm N	
II	X. LY	X. LY	X. LY	X. LY	II
	Z. MY	Z. MY	Z. MY	Z. MY	
	X. lM ⁻¹ Z	X. LM ⁻¹ Z	X. Lm ⁻¹ Z	X. lm ⁻¹ Z	
	X. LM ⁻¹ 'Z	X. lM ⁻¹ 'Z	X. lm ⁻¹ 'Z	X. Lm ⁻¹ 'Z	
	X. l,m ⁻¹ Z	X. L,m ⁻¹ Z	X. L,M ⁻¹ Z	X. l,M ⁻¹ Z	
	NM L	LM ⁻¹ N	L ⁻¹ N M ⁻¹	lm ⁻¹ N	
III	Y. LX	Y. LX	Y. LX	Y. LX	III
	Y. MZ	Y. MZ	Y. MZ	Y. MZ	
	X. L ⁻¹ mZ	X. l ⁻¹ MZ	X. L ⁻¹ MZ	X. l ⁻¹ mZ	
	X. l ⁻¹ m'Z	X. L ⁻¹ M'Z	X. l ⁻¹ M'Z	X. L ⁻¹ m'Z	
	X. L _l ⁻¹ MZ	X. l _l ⁻¹ mZ	X. L _l ⁻¹ MZ	X. l _l ⁻¹ mZ	
	LN M	NM ⁻¹ L ⁻¹	L ⁻¹ M N	l ⁻¹ m N	
IV	Y. LX	Y. LX	Y. LX	Y. LX	IV
	Z. MY	Z. MY	Z. MY	Z. MY	
	X. l ⁻¹ m ⁻¹ Z	X. L ⁻¹ m ⁻¹ Z	X. l ⁻¹ M ⁻¹ Z	X. L ⁻¹ m ⁻¹ Z	
	X. L ⁻¹ m ⁻¹ 'Z	X. l ⁻¹ m ⁻¹ 'Z	X. L ⁻¹ M ⁻¹ 'Z	X. l ⁻¹ M ⁻¹ 'Z	
	X. l _l ⁻¹ M ⁻¹ Z	X. L _l ⁻¹ m ⁻¹ Z	X. l _l ⁻¹ M ⁻¹ Z	X. L _l ⁻¹ m ⁻¹ Z	
	l ⁻¹ m ⁻¹ N	LN M ⁻¹	NM L ⁻¹	L ⁻¹ M ⁻¹ N	
	1	2	3	4	

distribution, unless the association be required every day or every hour. Though I have read music for forty years, I have never known the crotchet rest from the quaver rest, except by

context. These two symbols turn their heads one backwards and the other forwards, a difference which bears no imaginable relation to one standing for twice as much time as the other.

The Roman numerals refer to figure; the Arabic to phase. The first two lines in each compartment contain the premises. The third line contains the conclusion in affirmative form, derived from reduction into the primary phase of the first figure. The fourth and fifth lines show the two forms of negative conclusion. In the sixth line N is the concluding relation, affirmative or negative according as the premises are of similar or different qualities: and the connexion of N with the premising relations is seen, as obtained by simple composition when the premises are of the same quality, and from opponent syllogism, or from the rule above, when the premises are of different quality.

The sixth line is the only one which will need any detail of consideration. When the premises are of one quality, so that N is not to be disengaged by decomposition, it is enough that N should be identical with, or should contain, the relation set down opposite to it. Thus in III. 4, the inference is that X is one $l^{-1}m$ of Z, or one N of Z, if only $l^{-1}m$ be contained in N. The enlargement of course is a weakening of the inference, an addition of scope* and diminution of force.

Let the premises, as in II. 1, be X . LY and Z .. MY, L being any one L, and M some one M. The reduction to I. 1 gives X .. LY and Y .. $M^{-1}Z$, whence X .. $LM^{-1}Z$ is all the conclusion that can be drawn. Of this X . $LM^{-1}Z$ and X . $l^{-1}m^{-1}Z$ are equivalents. Again, if the conclusion be X . NZ, it is clear that X .. NZ and Z .. MY, M being still some one M, should give X .. LY, and do give X .. NMY, whence NM and L should be identical. If we examine $NM \parallel L$, upon the condition that M is some one M, left vague, but not any one M, we see that it gives $N \parallel LM^{-1}$. For L is to include in its meaning any N of a certain M, and nothing else: so that N is LM^{-1} , where that M^{-1} is used which is the correlative of the M in question. But in *denying* this LM^{-1} , or rather any L of this vague M^{-1} , we do but deny LM^{-1} .

This point is well illustrated by relations in which degree or quantity is conceivable. For example, let X . LY be 'X is not an external of Y;' and let Z .. MY be 'Z is a genus of Y'. The inference is that X is not an external of *all* species of Z. Since the species may be as nearly the whole genus as we please, and even the whole genus itself, the only inference is that X is not an external of Z. Again, we ask *what* of a particular genus is an external, the genus in question being vague. If the particular genus were known, we should say that the required class is not *partient* of that genus to any extent except some or all of the exience of the genus: but as this exience is quite vague, possibly nothing, we can only say not partient at all or external. In both cases X . $\{ \} . \{ \} Y$ and Z .. $\{ \{ \{ \} Y$ gives X . $\{ \} . \{ \} Z$, or X $() Y$) Z gives X $() Z$.

I shall remember it in future, having looked it up for the purpose of this note, by seeing that the crotchet rest turns its head forwards, the quaver rest backwards; and assuming that progress is worth twice as much as retrogradation. In the case before me, the difficulty of attaching $-+$ and $+ -$ to the figures of which they are the primary phases may be lessened to those who are constituted like myself by remembering that the second figure is that of reference *to*, and that in $-+$ we read *to* the chief sign $+$, while the third figure is that of reference *from*, and that in $+ -$ we read *from* the sign $+$.

VOL. X. PART II.

* In my last paper, speaking of the world at large as rudely acquainted with the *intension* of a term under the name of its *force*, I omitted, by one of those pieces of forgetfulness which are hard to account for, to add that they are also acquainted with *extension* under the name of *scope*. And many cases occur in which writers choose their terms as if they felt that the greater the scope the less the force, and use them accordingly: but I cannot find anything like a direct statement of the theorem, though I should suppose it can hardly have been missed by all writers.

In the same way other cases may be treated. But the entrance of contrary relations renders the method of decomposition useless for every purpose except historical comparison.

Except when both premises are negative, the conclusion can always be expressed in terms of the premising relations, without contraries. Thus among the concluding forms of III. 2, we see $L^{-1}M'$. The following rules may be collected. First, the relations converted in the conclusions belong to those premises which must be converted when reduction is made into the first figure. Secondly, the mark of inherent quantity appears in the ordinary form of conclusion only when the premises are of different qualities. Thirdly, when the conclusion is expressed without contraries, this mark is always attached to the relation of the affirmative premise. These rules would give mechanical canons of inference, if such things were wanted: and it would be well to remember that in the *second* figure the middle term usually comes *second* in both premises, and the *second* premise is converted in reduction into the first figure.

I shall now proceed to the consideration of the quantified proposition and its syllogism, presuming the reader to be acquainted with the notation and classifications of my second and third papers. If we take the proposition 'Every X is an L of one or more Ys' we may denote it by $X \)) LY$: and similarly $LY \)) X$ may denote 'Every L of any Y or Ys is an X.' And similarly for the other parts of the notation.

I enter on this part of the subject only so far as to illustrate the ancient or Aristotelian syllogism. Though of necessity a part of logic, as involving possible forms and necessary connexions, the quantified syllogism of relation is not of primary importance as an explanation of actual thought: for by the time we arrive at the consideration of relation in general we are clear of all necessity for quantification. And for this reason: quantification itself only expresses a relation. Thus if we say that some Xs are connected with Ys, the relation of the class X to the class Y is that of *partial connexion*: that some at least, all it may be, are connected, is itself a connexion between the *classes*. Nevertheless, it may be useful to exhibit the modifying quantification as a component, not as inseparably thought of in the compound; though in this we must confine ourselves to what may be called the *Aristotelian* branch of the extended subject. If we would enter completely upon quantified forms, we must examine not only the relation and its contrary, but the relation of a term in connexion with the relation of the contrary term. And here we find that all universal connexion ceases. The repugnance of X and not-X or x, which, joined with alternance, is the notion the symbols X and x were invented to express, cannot be predicated of LX and Lx: for Y..LX and Y..Lx may coexist. The complete investigation would require subordinate notions of form, effecting subdivisions of matter.

This complete examination would also require the investigation of the manner in which quantity of relation acts upon quantity of term: and this whether the quantity of relation be inherent or not; including an examination of all syllogisms in which inherent quantity of relation *appears in the premises*. And thus in logic, as in mathematics, the horizon opens with the height gained: generalisation suggests detail, which again suggests generalisation, and so on *ad infinitum*. There is no more limit to the formulæ of thought than to the

formulae of algebra. The logician may, if it please him, reduce all thought to simple assertion or denial of identification, and the algebraist may define all his science as either $x = y$ or $x = y \pm a$: one reduction is as true as the other. There is identity or difference in every possible logical judgment: there is equation or inequation in every possible algebraical judgment.

In the Aristotelian syllogism, the premising forms are $X \rightarrow Y, X \rightarrow Y, X \rightarrow Y, X \rightarrow Y$; X being the subject and Y the predicate. The forms $X \rightarrow (Y \text{ and } X), Y$ cannot appear, unless we add so much of Hamilton's system as is seen in them. Nor can we avoid doing this here. For conversion from figure to figure is no longer conversion of order of terms. Thus $LX \rightarrow Y$ and $Y \rightarrow MZ$, do not give the first figure, but the third: there being reference from the middle term in both premises; that is, the middle term being the subject of relation in both cases.

In all the syllogisms which do not involve the forms (\cdot) and (\cdot) , that is, in all which are either Aristotelian or capable of being made so by simple conversion, each premise is a congeries or aggregation of propositions involving individual notions, such as we have hitherto considered. An adequate quantification of the middle term insures the collection of a number of pairs, one out of each premise, in which the same individual from the middle term appears in both the premises: and thus the ordinary laws of dependence upon the quantities of the terms may be established. The whole of the system of relations of quantity remains undisturbed if for the common copula 'is' be substituted any other relation: so that the usual laws of quantity may be applied to the table of *unit-syllogisms* given above, precisely as if L and M only meant 'is.' Thus $X \rightarrow LY$ and $Y \rightarrow MZ$ giving $X \rightarrow LMZ$ or $X \rightarrow LM'Z$, we find that $X \rightarrow (LY \text{ and } Y \rightarrow MZ \text{ gives } X \rightarrow LM'Z$.

In the first three figures, the pure Aristotelian modes are derived entirely from the first and third phases, and in no case from the second or fourth. But all the phases of the fourth figure give such syllogisms except the first.

Every one of the thirty-two forms of onymatic syllogism may be made to give some conclusion, however the relations may be distributed: but the results are at present of inferior interest, for reasons already given. Thus $X \rightarrow LY, MY \rightarrow (Z \text{ give } X \rightarrow LY, MY), z$, or $X \rightarrow LY, Y \rightarrow M^{-1}z$, or $X \rightarrow L, M^{-1}z$. But direct relation between X and Z is here unattainable, without reference to the matter of L and M .

I now proceed one step nearer to the common syllogism, as follows. Let only one relation and its converse appear in the premises; and let this relation be *transitive*. That is, each relation is either L or L^{-1} , and LL is L , $L^{-1}L^{-1}$ is L^{-1} . The most convenient relations from which to form instances will be 'ancestor' and 'descendant.'

Every phase of every figure gives its conclusion: but our question will be to determine those cases in which the concluding relation is, or may be, the relation of the premises, L or L^{-1} . We may have a larger conclusion: if so, we throw away a part of it. To illustrate this, let us examine I. 3: let $X \rightarrow LY$ be the minor premise, and let $Y \rightarrow L^{-1}Z$ be the major. The full conclusion is $X \rightarrow L, L^{-1}Z$. This contains $X \rightarrow L^{-1}Z$: for, as before seen, when L is transitive, L, L^{-1} contains L^{-1} . Thus when X is an ancestor of Y , and Y not a descendant of Z , X is not a descendant of Z . This of course is easy: if X were a descendant of Z ,

then Y, a descendant of X, would also be a descendant of Z, which he is not. But this is not all the conclusion. The full conclusion is that X is not an ancestor of none but descendants of Z: not Z himself nor herself, not his wife nor her husband, not any descendant of Z, and not the wife nor the husband of any descendant; unless, in the cases where wife or husband is mentioned, there be another marriage and a fruitful one with a non-descendant.

Looking through the phases of the figures, and making L the minor relation in all cases, the major relation being L or L^{-1} , we have the following Table of cases in which L or L^{-1} is a legitimate conclusion.

	1	2	3	4
I	X..LY	X. LY	X..LY	
	Y..LZ	Y.. $L^{-1}Z$	Y. $L^{-1}Z$	—
	X..LZ	X. LZ	X. $L^{-1}Z$	
II	X. LY	X..LY	X..LY	
	Z..LY	Z.. $L^{-1}Y$	Z. LY	—
	X. LZ	X..LZ	X. $L^{-1}Z$	
III	Y..LX	Y. LX	Y..LX	
	Y. LZ	Y..LZ	Y.. $L^{-1}Z$	—
	X. LZ	X. $L^{-1}Z$	X.. $L^{-1}Z$	
IV		Y..LX	Y. LX	Y..LX
	—	Z. $L^{-1}Y$	Z.. $L^{-1}Y$	Z..LY
		X. LZ	X. $L^{-1}Z$	X.. $L^{-1}Z$

In rejecting all conclusions which do not contain L or L^{-1} , we must not forget that these conclusions exist: I was only, by such rejection, preparing the way for the complete analogues of the common syllogism. For instance X..LY, Y.. $L^{-1}Z$, give X.. $LL^{-1}Z$, not necessarily either LZ or $L^{-1}Z$, though possibly either. But still it is a conclusion, and to some persons an important one: for if L mean *descendant*, and therefore L^{-1} *ancestor*, then, Z being the Queen, X is entitled to an honorary degree.

In my second paper I pointed out the law according to which L and L^{-1} are distributed. The radical forms of the four figures are here ++, -+, +-, --; in my former paper, in which, according to usual practice, the major premise was written first, the radical forms were ++, +-, -+, --. The rule is, that the radical form does not admit the converse relation: but that when one premise differs in quality from the radical form, the converse relation is thrown upon the other; when both, upon the conclusion.

Agreeing with the logicians that all judgment either identifies or separates two objects of thought, I maintain against them that this great alternative, though a real form inherent in all *judgment*, does not give the whole basis of the fundamental act of *reasoning*, or comparison of judgments. The old logicians carried their system all the length which its pretensions justified: the modern logicians, without abating a jot of the pretension, have tacitly dropped greatly short of the length. The restorer of logical study in England, Archbishop Whately, directs against many of his predecessors the reproach that, strongly as they contend for the syllogism containing the whole form of inferential thought, they seem never to use it nor to care about it when they come to their so-called applications of logic. I sup-

pose that the parties inculcated found that the ordinary syllogism does not very frequently contain the act of reasoning. And in truth, when it does appear, it is usually *Barbara* or *Celarent*, that is 'Species of species is species' or else 'Species of external is external:' both contained in the principle that the part follows the whole as to inclusion or exclusion. Of the common logical heads, the study of the term and of the proposition, of the aggregates and components of the term, and of the transformations of the proposition, is far more necessary, presents points of far more frequent occurrence, and holds out far greater occasion for warning, than the study of the syllogism, when limited to the arithmetical *abacus*.

If the ordinary syllogism deserved the character given of it, a certain chapter in the older books of logic, instead of dropping into desuetude, would have increased in size and importance, with good assurance of addition to both. I mean the chapter *De Inventione Medii Termini*. This part of the subject was enlarged into many heads by the latest of the older writers: but in those who most resemble the genuine schoolmen, as Sanderson for example, the pure heading above given is preserved and its subject treated within the limits of the phrase. If all reasoning be reducible to ordinary syllogism, it follows that any assertion *inferred* about two terms must arise from comparison of the two by aid of some middle term, which is therefore to be investigated. Accordingly, a universal negative can only be established by finding out a third, or middle, term, in which one of the terms of the conclusion is wholly contained, and from which the other is wholly excluded. So necessarily is this invention of a middle term the act of investigation, if the syllogism, as given, be what it is said to be, that the mode of arrival at the missing element is very properly formalised into memorial verses *Fecana*, *Cageti*, &c., which ought to have followed *Barbara*, *Celarent*, &c., as practice follows theory.

When by the word *syllogism* we agree to mean a composition of two relations into one, we open the field in such manner that the invention of the middle term, and of the component relations which give the compound relation of the conclusion, is seen to constitute the act of mind which is always occurring in the efforts of the reasoning power. Was an event the consequence of another? We know that consequence of consequence is consequence, and, X being a suspected consequence of Z, we examine various Ys, and try if for any one of them we can establish that X is a consequence of Y and Y of Z. We do not consciously refer our search after relation to the notion of relation, nor our act of composition to the notion of composition; so that our descriptions of mental processes, when exhibited in technical terms, are as strange as our daily syntax when explained in phrases of grammar to an uneducated but tolerably correct speaker. The person X, did he commit the act Z? Non-possession of motive is, taken alone, probable innocence: non-production of motive is probable non-possession. We try for a motive Y, to which X is related by possession, and Y to Z by sufficiency. Here are the premises—X is the possessor of the motive Y; Y is a sufficient motive to commit Z; therefore X is the possessor of a sufficient motive to commit Z; and this compound relation is extensively contained in—or intensively contains—the relation of 'sufficiently in connexion with the action to give the evidence of actual commission a claim to consideration under ordinary notions of probability.' A very complicated concluding relation; but very familiar in action both to judge, counsel, and jury. But all this is not

ordinary syllogism. The old logicians were right in attaching importance to the invention of the middle term: but their right notion was deprived of efficient action by their determining that no connexion worthy of a logician's attention could exist between terms except *is* or *is not*.

Any two notions whatsoever may happen to possess relation to each other in the mind. Choose two notions at hazard: the chances are small that they are related by inclusion or exclusion, total or partial, in any manner worth consideration: but these chances are multiplied a thousand fold if we turn our thoughts to the likelihood of their existing in some other relation. Indeed, some relation *must* exist between any two things, over and above the relations, usually well settled, of identity or difference.

When we examine any book of ordinary reasoning, we find that the onymatic syllogism is not very frequent, the combination of relations much more frequent, and the introduction of composition of terms and transformation of propositions by far the most frequent of all. Syllogisms are *rather chapters than sentences*, in many cases. When the acts of inference follow one another very quickly, or the reasoning is very consecutive, people begin to cry mathematics. I have read and heard the statement that Fearne's celebrated work on *contingent remainders* is *algebra*: it is no more algebra than a remainder-man is $x - y$; but the reasoning, if I may speak from a very old recollection of a few chapters, is remarkably sustained and connected. Chillingworth is a writer who delights in the technical exhibition of a syllogism, when he gets one: but the instances exhibited do not come very thickly. Nothing that I know of can be written *all* in syllogism, except mathematics: and this merely because, out of mathematics, nearly all the writing is spent in loading the syllogism, and very little in firing it.

It has sometimes been made a reproach to logic that the mathematicians, who reason more consecutively than any others when about their mathematics, do not regard the syllogism with respect in theory, and disdain it in practice. I shall proceed to examine how this matter stands.

First, as to the merest *technical* exhibition of the syllogism, it is, or should be, evident to all parties that such display of form is no more necessary to a proficient than the spelling of every word as he reads it. Those who cannot exhibit their inferences syllogistically need to learn; but those who can do not need to practise: which is exactly what may be said of spelling. When I wrote this last word, I was quite unconscious of s-p-e-l-l-i-n-g: no perceptibly separate acts of my mind dictated the writing down of the separate letters. This is all that need be said in answer to those who despise the analysis which is good for the learner, because the logician himself ends, in practice, by using the composite process with which the learner began.

There is a useful but very limited field of exercise for the syllogism in geometry. There is hardly an instance, over and above the elimination of B from $A = B$, $B = C$, which is not an overt use of the *principium et exemplum*: whenever P is true, Q is true; in this case P is true; therefore in this case Q is true. The reduction into the pure technical form, except in a few instances at the commencement, would be useless. The attempt of Herlinus and Dasypodius, of which Mr Mansel (Appendix to *Aldrich*, note L) has reprinted one pro-

position, is of use to the learner when carried to the extent to which he and Mr John Mill have carried it, that is, the exhibition of one proposition, to be repeated a few times for practice. But there is a far better logical exercise in Euclid. This great leader has, equally with Aristotle, a style of his own, and one full of its own technicalities: but utterly divested of any the smallest distinction between form and matter. This is most fortunate for that student for whom a further guide is provided: the book before him is raw material on which the exercise of thought about form and matter can be far more profitably carried on than it could have been if Euclid had made the distinction. And this especially on two points.

First, a geometrical proposition may either be a purely *formal* consequence of those which precede, or it may require (as most do) a further infusion of geometrical *matter*. When Euclid has proved that a *non-central* point inside a circle, or outside, is *not* a point to which three equal lines can be drawn, he holds himself *not* to have completed the proof that a point to which three equal lines *can* be drawn *is* the centre. But his demonstration is nothing except his often repeated transition from one to the other of the contrapositive forms of a universal affirmative proposition. It is not in his system to establish a purely logical inference once for all: accordingly, 'not-X is always not-Y' is converted into 'Y is always X' by one and the same train of thought whenever it is wanted. That the common end of three equal lines *is* the centre follows equally from the *non-centre not* being such common end, whether or no the reasoner can say what a circle is, or a centre, or a common end.

Again, this same want of admission of what logicians call *contraposition* gives rise to the majority of the *ex absurdo* demonstrations: in fact the *reductio ad absurdum* is usually nothing more than the mode of making the passage from the direct to the contrapositive form. When (in I. 6) it is to be shown that equal angles give equal sides, what Euclid really shows—that is, the geometrical *matter* of his proposition—is that unequal sides give unequal angles. His unequal sides immediately produce unequal areas with a pair of sides equal, each to each: whence, by I. 4 contrapositively taken, the included angles are unequal. All that is *ex absurdo* serves only to show that 'unequal sides give unequal angles' is identical with 'equal angles give equal sides,' and to admit of the direct, instead of the contrapositive, form of I. 4.

From such instances, and many others, I derive my now long fixed opinion that geometry is of little, though some, account for technical exercise in the syllogism; of more for exercise in the transformations of the proposition; of most of all, and of very much, for exercise in the separation of form and matter.

It says but little for the truth of the views taken of logic that this science and geometry lived so long in the same family—the old school of arts—without any attention being paid to the bearing of the first upon the second. But it is to be remembered—to say nothing of Euclid being *κύριος στοιχειωτής* and above criticism—that the form of contraposition, though known and duly registered, was, by reason of the neglect of contrary or privative terms, very little used or thought about: and also that the distinction of form and matter was never completely *envisaged*, though influential. That the *logicians*—and it must be remembered that *logicus* meant student or graduate *in arts*, in all its intension—prone as they were to syllogise, never threw the propositions of Euclid into technical form, must be taken as a point

in their favour. Perhaps it would have been asserted as a matter of course that they did so, omission of all mention being taken as equally a matter of course, if the publication of Herlinus and Dasypodius, the only one of its kind, had not come in as the exception which proves the rule.

It is to *algebra* that we must look for the most habitual use of logical forms. Not that onymatic relations are found in frequent occurrence: but so soon as the syllogism is considered under the aspect of combination of relations, it becomes clear that there is more of syllogism, and more of its variety, in algebra than in any other subject whatever, though the matter of the relations—pure quantity—is itself of small variety. And here the general idea of relation emerges, and for the first time in the history of knowledge, the notions of relation and *relation of relation* are symbolised. And here again is seen the scale of gradations of form, the manner in which what is difference of *form* at one step of the ascent, is difference of *matter* at the next. But the relation of algebra to the higher developments of logic is a subject of far too great extent to be treated here. It will hereafter be acknowledged that, though the geometer did not think it necessary to throw his ever recurring *principium et exemplum* into an imitation of “*Omnis homo est animal, Sortes est homo, &c.*,” yet the algebraist was living in the higher atmosphere of syllogism, the unceasing composition of relation, before it was admitted that such an atmosphere existed.

I expect agreement in what I have said neither from the logicians nor from the algebraists: but, for reasons given in my last paper, I do not submit myself to either class. Not that I by any means take it for granted that all those who have cultivated both sciences will agree with me. When two countries are first brought by the navigators into communication with each other, it is found that there are two kinds of perfect agreement, and one case of nothing but discordance. All the inhabitants of each of the countries are quite at one in believing a huge heap of mythical notions about the other. At first, the only persons who though similarly circumstanced nevertheless tell different stories are the very mariners who have passed from one land to the other. This will go on for a time, and for a time only: *multi pertransibunt, et augebitur scientia.*

A. DE MORGAN.

UNIVERSITY COLLEGE, LONDON,
November 12, 1859.

APPENDIX.

ON SYLLOGISMS OF TRANSPOSED QUANTITY.

IN my *Formal Logic*, and in my recently published *Syllabus of a proposed System of Logic*, I gave instances of the *syllogism of transposed quantity*: that is, the syllogism in which the whole quantity of one concluding term, or of its contrary, is applied in a premise to the other concluding term, or to its contrary. As in the following:—Some Xs are not Ys; for every X there is a Y which is Z: from which it follows, to those who can see it, that some Zs (the some of the first premise) are not Xs.

Such syllogisms occur in thought and in discussion. It also happens that the premises and conclusion are stated independently, and their connexion not seen. It may also happen that the premises are stated simultaneously with the contrary of the conclusion. The following sentences, though they will not pass current in a paper on logic which produces them as an example of fallacy, would be very likely to slip through without detection, as part of an ordinary page of writing:—

To say nothing of those who achieved success by effort, there were not wanting others of whom it may rather be said that the end gained them than that they gained the end: for they made no attempt whatever. But for every one who was more fortunate than he deserved to be, as well as for every one who used his best exertions, one at least might be pointed out who abandoned the trial before the result was known. And yet, so strangely are the rewards of perseverance distributed in this world, there was not one of these fainthearted men but was as successful as any one of those who held on to the last.

Might not many educated logicians pass this over, supposing it presented without warning, as containing nothing but what might be true, without seeing that, except under forced interpretation, it combines in one the assertions that *all are* and that *some are not*?

The syllogism of transposed quantity is essentially a case of the numerically definite syllogism, though the number of instances is in every case of the indefinite, or rather unspecified, character of the algebraical letter: and the same may be said of every onymatic syllogism. Those who have commented upon the arithmetical syllogism have for the most part missed this point: they have not seen that the *numerical* definiteness of the premises is the definiteness of general, not of particular, symbols. That is, they have not caught the distinction between the form and the matter of arithmetical definition. The following slight account of the numerical syllogism will be sufficient for the present purpose.

Let us understand by mXY that m or more Xs are Ys; and by $m:X Y$ that m or fewer Xs are Ys. Then by mXY we also mean, if x and y be the whole numbers of Xs and Ys in the universe, both $(x - m):Xy$ and $(y - m):xY$. Let u be the number of instances in the universe; x, y, z , the numbers in X, Y, Z; and x', y', z' , the numbers in x, y, z . Then mXY is $(x - m):Xy$, or $(y' - x + m)xy$, or $(m + u - x - y)xy$. And mXy is $(m + u - x - u + y)xY$, or $(m + y - x)xY$.

Let mXY and nYZ coexist: we infer $(m + n - y) XZ$, or $(m + n + u - x - y - z) xz$.
 Let mXy and nYZ coexist: these are mXy and $(n + u - y - s) yz$; from which we infer
 $(m + n + u - y - s - y') Xz$, or $(m + n - s) Xz$ and $(m + n - x) xZ$.

Call the number of instances the (logical) extent of the term or proposition. Then it appears that when the two premises have the middle term Y in both, or y in both, the two forms of conclusion take from the premises, the one both terms direct, the other both terms contraverted: but when the middle term enters in both forms, Y and y , the two forms of conclusion take each one term direct from the premises, and one term by contraversion. In the first, the *coefficients of extent* in the forms of conclusion are the united extent of the premises diminished by that of the middle term, and the united extent of the premises and of the universal diminished by the united extent of the three terms. In the second, the coefficients of extent are both described by the united extent of the premises diminished by the extent of the contraverted term.

We can now deduce either the ordinary syllogisms or those of transposed quantity, belonging to any one case of the numerical syllogism. Let the premises be

$$mXY, nyz, \text{ so that } (m + n - x) xz, (m + n - z') XZ,$$

are the forms of the conclusion. From $m = x$, we deduce nxz and $(x + n - z') XZ$; of the second of which we can say nothing without further knowledge of the relations of extent. On the meaning and character of the second form I may refer to my *Formal Logic*. From xXY and nyz we have then nxz ; that is, using the notation of my second and third papers, from $X))Y$ and $Y)(Z$ we deduce $X)(Z$. Similarly, from $m = x$, $n = z'$ we show that $X))Y))Z$ gives $X))Z$: from $n = z'$ alone, we deduce that $X()Y))Z$ gives $X()Z$.

To find such syllogisms of transposed quantity as this form gives, let $n = x$: then mXY and xyz give mxz . That is from 'Some Xs are Ys, and for every X there is something neither Y nor Z' we deduce 'Some things are neither Xs nor Zs.' When one term imparts its quantity to another, let the imparting term have a symbol placed above its spicula of quantity, and the receiving term below. Thus what we have just arrived at is that $X(\bar{)}Y)(Z$ gives $X)(Z$. It must be specially observed that the term which imparts is always particular: thus when we see $X()Y)(\bar{Z}$, in which Z is universal and z particular, the meaning of $X()Y$ is 'For every z there is an X which is Y.' It is also to be remembered that in the formation of the symbol of conclusion the spicula of the imparting term is always to be inverted: thus $X(\bar{)}Y)(\bar{Z}$ does not give $X)((Z$, but $X)(Z$.

When a term takes the *whole quantity* of a term external to its proposition, it will be convenient still to call the proposition *universal*, and, for distinction, *externally universal*. The ordinary universal may be called *internal*. When a *conclusion* is spoken of as universal, it is meant as being internally universal.

The circumstances under which two premises have a valid conclusion are precisely those of the ordinary syllogism. Two universals, either or both of which are externally so, give a conclusion, universal or particular according as the middle term is of unlike or like quantities in the two premises. A universal and a particular with the middle term of unlike

PDY	USY	YDP	YSU
$\bar{()}) () ($	$\bar{() () () ($	$()) \bar{() ()$	$() (\bar{() ()$
$\bar{.)}) ((($	$\bar{.) () ((($	$) .) \bar{() .)$	$) .) (\bar{() .)$
$\bar{) ((((($	$\bar{)) (((($	$) ((\bar{.)}) .)$	$) () . \bar{.)}) .)$
$\bar{) (() ()$	$\bar{)) () ()$	$) (()) ($	$) () \bar{) } ($
$\bar{.)}) .) ()$	$\bar{.) (.) .) ()$	$) .) . \bar{.) } (($	$) .) (. \bar{.) } (($
$\bar{() } .) .) .)$	$\bar{() (.) .) .)$	$() .) . \bar{() (($	$() (. \bar{() (($
$\bar{.) (() .) .)$	$\bar{.) . () .) .)$	$(. (() ((($	$(. () \bar{.)} (($
$\bar{.) ((.)) ($	$\bar{.) . (.)) ($	$(. ((. \bar{() ()$	$(. () . \bar{.)} ()$

We have here given the symbols of the premises, followed by the symbol of the conclusion: from which the syllogisms may be read at length. Thus the last syllogism under YDY is as follows;—For every z there is an X which is not Y; for every X there is a Y which is not Z: whence every X is Z.

The several cases in UDY and YDU are inverted readings each of the other: those in YDY and YSY are essentially different. The cases in USY and YSU are but strengthened forms of those in PDY and YDP; the particular in the second being converted into an internal universal which contains it by an alteration in the quantity of the middle term, without any accession to the conclusion. The forms in YDY are derived from those in PDY and from those in YDP by strengthening—or at least rendering less vague,—the particular proposition by giving it that quantity which makes it an external universal: and the conclusion is thereby strengthened into a universal.

The following comparison will illustrate and extend the preceding remarks. In ordinary syllogism, the existence of valid inference depends upon the presence of U and D; that is, either U must be present twice; or U once, and D. In UDU, the most powerful of valid forms, the inference is U: in USU, PDU, UDP, it is only P. In USP, PSU, PDP, PSP, there is no inference: of these the first three may be said to be one remove from inference, and the fourth two removes. All this may be said of the cases in which the external universal is allowed to enter. Thus PSP, now two removes from inference, is made valid by such accessions as make it PDY, YDP, or YSY: each accession being either a change from S to D, or alteration of P into Y.

Of all the transposed syllogisms, one half, being all in the first compartment, are either identical with, or contained in, syllogisms of the ordinary kind. Of those in UDY, the one marked $\bar{() ($ is contained in, and contains, $||)$; and $\bar{.) ($ is similarly identical with $|.)$). Of those in YDU, $())$ is identical with $((|$: and so on. Of those in YDY, $()) ($ is contained in, but does not contain, $))))$; $\bar{.)}) ($ is contained in $(.))$; and so on. Of those in YSY, $() ($ is contained in $)) (($; and so on. Overlooking strengthened forms, it thus appears that the really new cases are all contained in PDY and YDP, of which either is but an inverted reading of the other.

A. DE MORGAN.

VIII. *On the Motion of Beams and thin Elastic Rods.* By J. H. RÖHRS, M.A.
Fellow of the Cambridge Philosophical Society.

[Read April 23, 1860.]

DURING a residence in Switzerland my attention was occasionally directed to certain specimens of its ancient national weapon—the steel cross-bow, which I had seen exposed for sale in the shops of dealers in curiosities, and the idea struck me that some such instrument might be serviceable in experiments on the resistance of the air to projectiles of different forms and specific gravities; besides I was curious to compare the efficiency of the “Arbalete” with that of our English long-bow. Accordingly I had no less than three arbaletes made for me in succession by a very skilful Swiss armurier*, the third arbalete stronger than the second, and the second stronger than the first, but I could not succeed in obtaining anything like the velocity I had anticipated; in fact, 200 feet a second seemed about the superior limit, a velocity far too low for my purposes. This induced me to investigate *ab initio* by the aid of analysis the motion of a vibrating bow. In order to simplify the subject, I began by considering the motion of an uniform thin elastic lamina depressed at one end, and then suddenly released; the partial differential equation which I obtained in this case is the same as that of Poisson, and of which he has given a solution in the shape of a definite integral, which however does not seem easily available for the particular calculation I was engaged in. The differential equation for the motion of a common long-bow or steel-bow is of course different; it depends on the law of the thickness of the spring, which is much stouter in the centre than at the ends; but as the simpler equation for the motion of an uniform rod admits of such exact and pleasing integrations, and is so suggestive of the general phenomena of motion of vibrating rods, uniform or not, I attacked that in the first instance. A highly interesting problem closely connected with that I have more particularly considered, is the determination of the law of vibration of a Railway Girder under the action of a passing load; this when the load may be considered as collected at one point, and the mass of the girder is neglected, in comparison with that of the load, leads to an equation derived from simple considerations, but of which the numerical integration or tabulation, when the pressure of the load is not considered as approximately constant, is so extremely difficult, that I should not have ventured to attempt it, even if it had not been, as it has, accomplished by Professor Stokes, who, in conjunction with Professor Willis, has well nigh exhausted the

* M. Tschümy of Moudon.

subject of vibrating railway girders. There is one case, however, and that the most common one, in which the deflection of the girder is very slight, and the pressure of the load so nearly constant as to be capable of being so assumed, at least for a first approximation; in this case—whether the mass of the girder be neglected or not—the problem admits of an easy solution by the aid of Fourier's Functions; and the central deflection can be exhibited in the form of a rapidly convergent series, and in a shape very convenient for discussion. Professor Stokes has also considered this case, but he has solved it by a quite different method from the one I have employed.

And now to proceed to the analysis.

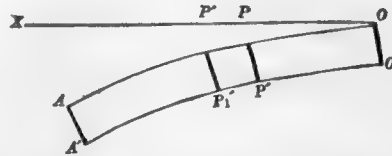

Let $AO, O'A'$ be a section of a slender elastic prismatic quadrangular rod made by the plane of the paper, which is supposed parallel to either of the narrow sides of the rod.

Let the length of the rod = a ,

..... thickness..... = h ,

..... breadth = k ,

$P'P, P_1'P_1$ an element length = δs ,

OX tangent at O the axis of x ,

$OP = s, y$ the ordinate at P .

Then the element $P_1'P'$ is kept at rest by the tensions and thrusts arising from the elasticity of the rod and by reactions $R, R + \delta R$ acting along $PP', P_1'P_1$. We shall assume that the elements of the rod are incapable of sliding over each other, and that the thickness remains uniform, so that all the laminæ of the rod will always have the same centre of curvature at the same time. We shall also suppose the rod to be so slightly disturbed that the longitudinal motion of its elements may be neglected; consequently the neutral axis will be in the middle of the rod. Also if we suppose m to be the mass of an unit's length and breadth of the rod, and Y a pressure arising from other than molecular forces extending over an unit's length and breadth of the rod at point (y, x) , we shall have

$$\frac{d^2}{dt^2} \left(\frac{dy}{ds} \right) = - \frac{R\delta s + \delta \left(\frac{ch^3}{3} \frac{d^2y}{ds^2} \right) \cdot k}{mk \frac{h^2}{12} \delta s},$$

$$mk \frac{d^2y}{dt^2} = - \frac{dR}{ds} + kY,$$

where C is a constant, depending on the elasticity.

If now $\frac{ch^3}{3}$ be very great, and h very small, $h^2 \frac{d^2}{dt^2} \left\{ \frac{dy}{ds} \right\}$ may be neglected in comparison with the other terms of the equation in which it stands, and we have finally,

$$m \frac{d^3 y}{dt^2} = - \frac{ch^3}{3} \frac{d^4 y}{ds^4} + Y.$$

If the rod had not been of constant thickness but of constant breadth, we should have had an equation of the form

$$m \frac{d^2}{dt^2} y \phi (s) = - a^2 \frac{d^2}{ds^2} (\phi s)^3 \frac{d^3 y}{ds^3} + Y.$$

First, for the motion of an uniform girder under the action of a passing load.

Let the load be supposed to occupy a small length 2β of the girder; 2β will be supposed ultimately to vanish.

Let Q be the pressure distributed over the space 2β , supposed uniformly so.

Let v be the velocity of the moving load, supposed uniform, along the girder.

Then if a be the length of the girder, Y will be made up of two parts mg and Y' , where Y' will = 0 till $s = vt$, if the load be supposed entering on the girder at time $t = 0$.

$$Y' \text{ will} = \frac{Q}{2\beta} \text{ from } s = vt, \text{ till } s = vt + 2\beta,$$

$$\text{and } Y' \text{ will} = 0 \text{ from thence to the end } s = a.$$

Now expanding Y' in a series of sines of $\frac{\pi ns}{a}$ between $s = 0$ and $s = a$, we have

$$\begin{aligned} Y' &= \sum \left[\frac{2Q}{a\beta} \left\{ \sin \frac{\pi n\beta}{a} \sin n \left(\frac{vt + \beta}{a} \right) \pi \right\} \frac{a}{\pi n} \sin \frac{\pi ns}{a} \right] \\ &= \sum \left(\frac{2Q}{a} \sin \frac{\pi nvt}{a} \sin \frac{\pi ns}{a} \right) \end{aligned}$$

in the limit when $\beta = 0$.

Hence writing b^2 for $\frac{ch^3}{3}$,

$$m \frac{d^2 y}{dt^2} = - b^2 \frac{d^4 y}{ds^4} + \sum \left(\frac{2Q}{a} \sin \frac{\pi nvt}{a} \sin \frac{\pi ns}{a} \right) + mg.$$

Let now $y = y' + y''$ where y'' is the part due solely to the statical deflection of the girder by its own weight.

$$\text{Then } 0 = - b^2 \frac{d^4 y''}{ds^4} + mg;$$

$$\therefore m \frac{d^2 y'}{dt^2} = - b^2 \frac{d^4 y'}{ds^4} + \frac{2Q}{a} \sum \left(\sin \frac{\pi nvt}{a} \sin \frac{\pi ns}{a} \right).$$

Now $\frac{d^2 y'}{ds^2}$, (or dropping the accent and assuming y for the dynamical deflection)

$$\frac{d^3 y}{ds^3} \text{ and } \frac{d^4 y}{ds^4} \text{ are both } = 0 \text{ when } s = 0 \text{ and } s = a,$$

because the beam is at rest at those points, and the radius of curvature is infinite there,

($\frac{d^4 y}{ds^4} = 0$, $s = 0$, and $s = a$, $\therefore y$ and $\therefore \frac{d^2 y}{dt^2} = 0$ at those points; $\frac{d^4 y}{ds^4} = 0$, $\therefore Y$ is = 0 there except for one instant).

Therefore expanding y in a series of the form

$$\Sigma \left(P_n \sin \frac{\pi n s}{a} \right),$$

we have

$$m \frac{d^2 P_n}{dt^2} = -b^3 \frac{\pi^4 n^4}{a^4} P_n + \frac{2Q}{a} \sin \frac{\pi n v t}{a}.$$

$$\text{Let } P_n = A_n \sin \frac{\pi^2 n^2 b t}{\sqrt{m a^2}} + B_n \sin \frac{\pi n v t}{a},$$

where A_n and B_n are constants to be determined.

If now the breadth of the girder be assumed = 1, and W be its weight, δ the central deflection for the weight W ,

$$\delta = \frac{W a^3}{b^3} \frac{5}{384},$$

$$m a g = W;$$

$$b^3 = \frac{W a^3}{\delta \frac{384}{5}};$$

$$B_n = \frac{\frac{2Q}{a}}{\frac{\pi^4 n^4}{a} \frac{W 5}{384 \delta} - \frac{W \pi^2 n^2 v^2}{a^3 g}}.$$

Again, because the girder has no initial velocity,

$$\frac{\pi^2 n^2 b}{\sqrt{m a^2}} A_n + \frac{\pi n v}{a} B_n = 0;$$

$$\therefore A_n = - \frac{v B_n}{\pi n a} \sqrt{\frac{384 \delta^3}{5 g}},$$

$$\text{or } B_n = \frac{2 \times 48 \delta}{\pi^4 n^4 - \frac{48}{a^2 g} \pi^2 n^2 \frac{v^2 W \delta}{Q}},$$

if δ be the deflection due to a weight Q at centre of the girder.

1st. We observe from (2) that if $v = 0$, and $vt = \frac{a}{2}$, the displacement at the centre by our series is

$$48\delta \left(\frac{2}{\pi^4} + \frac{2}{2^4\pi^4} + \&c. \right) = \delta,$$

as it ought to be, and the series is so convergent that taking only the first term we get a good approximation.

2ndly. The statical value of B_n is not much increased; as an extreme case, let

$$\delta^v = 1, \quad a = 420, \quad v = 60,$$

$$\delta^v = 1, \quad \frac{v}{a} = \frac{1}{7},$$

$$B_n = \frac{2Q \frac{384\delta^v}{5}}{\pi^2 n^2 \left(\pi^2 n^2 - \frac{384}{5 \times 32} \times \frac{1}{49} \right)},$$

or the denominator is diminished in the ratio of

$$\pi^2 n^2 : \pi^2 n^2 - \frac{12}{225}.$$

Now as the smallest value of $\pi^2 n^2$ is 10 nearly, this is about 201 : 200 nearly.

$$\text{But } A_n = -\frac{1}{7\pi n} \sqrt{\frac{384\delta^{2v}}{5g}} B_n$$

$$A_1 = -\frac{1}{7\pi} \sqrt{\frac{12}{5}} B_1 = -\cdot 07 B_1 \text{ nearly.}$$

$$\text{If } a = 460, \delta^v = \frac{5}{6}, \quad v = 44,$$

A_1 will = $-\cdot 042 B_1$ nearly; this is the same result almost exactly as was obtained by Professor Stokes in this example (the Britannia Bridge).

3rdly. We observe from (2) that if $\frac{W}{Q}$ be very small, B_n varies little from its statical value provided v be not very great; but if $\left(\frac{v}{a}\right)^2$ be very considerable, then the dynamical part of the denominator in B_n may rise to importance.

To prove the relations assumed between δ^v , δ , and b^2 , we proceed thus.

Let Q be the weight at the middle of the girder, R , R' the reactions at the ends of the girder. Then $R = \pm b^3 \frac{d^3 y}{ds^3}$ at those points positive at one end and negative at the other.

Also between $s = 0$, and $s = \frac{a}{2}$, we have for the equation to the curve

$$b^2 \frac{d^4y}{ds^4} = mg,$$

$$\frac{d^3y}{ds^3} = \frac{W}{a} \frac{s}{b^2} - \frac{Q}{2b^2} - \frac{W}{2b^2},$$

$$\frac{dy}{ds} = \frac{W}{a6b^2} \left(s^3 - \frac{a^3}{8} \right) - \left(\frac{Q}{2b^2} + \frac{W}{2b^2} \right) \left(\frac{s^2}{2} - \frac{a^2}{8} \right),$$

whence $\frac{ya}{2} = \frac{Wa^3}{b^2} \frac{5}{384} + \frac{Qa^3}{48b^2} = \delta' + \delta.$

If we had not assumed the pressure Q constant, we should have had to determine the motion of the girder

$$m \frac{d^2y'}{dt^2} = -b^2 \frac{d^4y'}{ds^4} + \frac{2Q}{a} \sum \sin \frac{\pi nvt}{a} \sin \frac{\pi ns}{a} \dots \dots \dots (1),$$

$$m' \frac{d^2y}{dt^2} = m'g - Q.$$

Now $y = y' + y''$, and $y'' = \phi(s)$, where $\phi(s)$ is the statical form of the girder at rest, and $s = vt$;

$$\therefore m' \frac{d^2y'}{dt^2} + m' \frac{d^2}{dt^2} \phi(vt) = m'g - Q \dots \dots \dots (2).$$

The statical value of y' is given by the equation

$$b^2y' = \frac{Q}{3a} (a - s_1)^2 s_1^2 - W \left(\frac{s_1^3}{12} - \frac{s_1^4}{24a} - \frac{a^2 s_1^2}{24} \right).$$

Hence between 1 and 2, eliminating Q if it were possible, we might solve the problem.

An easier example where the pressure varies, is the motion of a beam suddenly loaded in the middle and allowed to sink.

Deflection of a girder suddenly loaded in the middle.

Let M' be the mass of the load imposed,

M the mass of the girder,

Q the pressure at time t exerted by the load on the girder. Then supposing the load collected at one point we shall have

$$m \frac{d^2y}{dt^2} = -b^2 \frac{d^4y}{ds^4} + \frac{2Q}{a} \sum \frac{\pi n}{2} \sin \frac{\pi ns}{a},$$

where it must be observed that y is the part of the ordinate due only to the weight in the middle, so that if y' be the value of the ordinate when no weight is imposed on the girder, $y + y'$ is the complete ordinate.

$$\text{Also } \frac{d^2y}{dt^2} \Big|_{y=\frac{a}{2}} = g - \frac{Q}{M'}.$$

$$\text{Let } y = \Sigma \left(P_n \sin \frac{\pi ns}{a} \right).$$

$$\text{Then } \frac{d^2y}{dt^2} \Big|_{y=\frac{a}{2}} = \frac{d^2P_1}{dt^2} - \frac{d^2P_3}{dt^2} = g - \frac{Q}{M'}.$$

(Stopping at the term P_3 , which will render the results sufficiently approximate.)

Hence substituting for Q , and writing M for ma , and putting

$$\frac{M + 2M'}{2M'} = e,$$

$$\left. \begin{aligned} e \frac{d^2P_1}{dt^2} - \frac{d^2P_3}{dt^2} &= -\frac{b^2\pi^4}{2M'\alpha^3} P_1 + g \\ -\frac{d^2P_1}{dt^2} + e \frac{d^2P_3}{dt^2} &= -\frac{b^281\pi^4}{2M'\alpha^3} P_3 - g \end{aligned} \right\},$$

whence P_1 and P_3 can be found when e is given.

Let δ be the statical central deflection due to the mass M' , then

$$b^2 = M' \frac{ga^3}{48\delta}.$$

If we assume $e = 3$, which makes $M = 8M'$, we shall find

$$P_1 + 240P_3 = -1.94\delta \left(1 - \cos \sqrt{\frac{\pi^4 g}{96\delta}} \times 30.4t \right) \text{ nearly,}$$

$$P_1 - \frac{P_3}{3} = .9\delta \left(1 - \cos \sqrt{\frac{\pi^4 g}{96\delta}} \cdot 34t \right) \text{ nearly;}$$

the greatest depression is 1.8δ nearly.

If we assume $e = 1$, or the mass of the girder indefinitely small, in proportion to that of the load, the greatest depression = 2δ within two places of decimals

$$= 2\delta \left(\frac{96}{\pi^4} + \frac{1}{81} \frac{96}{\pi^4} \right),$$

a very close approximation to its true value 2δ in that case.

To determine the motion of an elastic rod, fixed at one end and free at the other. This problem is much more difficult than that of the vibration of a rod, of which the two ends are at rest and the intermediate parts only in a state of vibration. I tried it by many methods, but returned to the one I first thought of, as after all the easiest and best for numerical calculation. I may observe by way of preliminary, that Fourier's series do not apply to this case, on account of the values of the derived functions of $f(s)$, the equation of

the curve being unknown at the limits $s = 0$, $s = a$. The plan I have adopted is as follows. I take a particular solution of the differential equation

$$\frac{d^2y}{dt^2} = -b^2 \frac{d^4y}{ds^4},$$

where $mb'^2 = b^2$, involving exponentials and sines of s with the argument p , and then obtain an equation with an infinite number of real roots to determine p , from the conditions of the problem, viz. that $\frac{d^2y}{ds^2}$, $\frac{d^3y}{ds^3}$ must = 0, $s = a$, and y and $\frac{dy}{ds}$ must be = 0 when $s = 0$. We have in this way an infinite number of solutions $y = D_n f(s, t)$, where D_n is an arbitrary constant; consequently, putting $t = 0$, we can take any number m of such solutions, and determine the m constants by the condition that $y = \Sigma \{D_n f(s, 0)\}$ may coincide in m points with the bent spring at rest; it will be found that, taking only the first three values of D_n , we shall have a very close approximation. Let then

$$y = \cos p^2 b' t (A_1 \sin ps + B_1 \cos ps + C_1 e^{ps} + D_1 e^{-ps}) \\ + \sin p^2 b' t (A_2 \sin ps + \beta_2 \cos ps + C_2 e^{ps} + D_2 e^{-ps}).$$

This, it will be observed, satisfies the equation

$$\frac{d^2y}{dt^2} = -b^2 \frac{d^4y}{ds^4}, \text{ where } b^2 = mb'^2.$$

Also the factor of $\sin p^2 b' t$ will be zero, according to the condition that the rod starts from a position of rest.

Hence, by the conditions

$$\frac{d^2y}{ds^2}, \frac{d^3y}{ds^3} = 0, \quad s = a, \quad \text{and} \quad \frac{dy}{ds} \text{ and } y = 0, \quad s = 0,$$

we have

$$B_1 + C_1 + D_1 = 0, \\ A_1 + C_1 - D_1 = 0, \\ -B_1 \cos pa - A_1 \sin pa + C_1 e^{pa} + D_1 e^{-pa} = 0, \\ B_1 \sin pa - A_1 \cos pa + C_1 e^{pa} - D_1 e^{-pa} = 0;$$

$$\text{whence } \cos pa = \frac{-2}{e^{pa} + e^{-pa}};$$

$$C_1 = D_1 \left(\frac{\cos pa + \sin pa + e^{-pa}}{e^{pa} + \cos pa - \sin pa} \right);$$

$$A_1 = D_1 \left(\frac{e^{pa} - 2 \sin pa - e^{-pa}}{e^{pa} + \cos pa - \sin pa} \right);$$

$$B_1 = -D_1 \left(\frac{e^{pa} + e^{-pa} + 2 \cos pa}{e^{pa} + \cos pa - \sin pa} \right).$$

Assuming for the vibration of the rod

$$y = \Sigma \{ (A_n \sin p_n s + B_n \cos p_n s + C_n e^{p_n s} + D_n e^{-p_n s}) \cos p_n^2 b t \},$$

where A_n , &c. are the n^{th} particular values of the general A_1 , &c., we find the above expression yet further reduced, and

$$A_n = D_n \{ 1 + e^{-p_n a} (-1)^n \},$$

$$C_n = D_n \{ e^{-p_n a} (-1)^{n+1} \},$$

$$B_n = -D_n \{ 1 + e^{-p_n a} (-1)^{n+1} \}.$$

These expressions are only useful in computing the first one or at most two values of C_n , B_n , and A_n , as after that $e^{-p_n a}$ may fairly be assumed = 0.

Perhaps it might be possible to develop *directly* any $f(s)$ in a series of terms similar to those we have found as particular solutions of the equation, but in any case it would be labour thrown away, as it is not necessary to consider more than the first two values of pa , and, by equating the differential coefficients in the statical curve,

$$y = \frac{3\delta}{2 \cdot a^3} \cdot \left(\alpha s^3 - \frac{s^3}{3} \right), \text{ where } s = 0,$$

we shall obtain an approximation quite close enough. Of course the most simple and natural method of solving any partial differential equation between two variables s , t , would be to obtain a particular solution

$$y_n = D_n f(p_n s), \phi(p_n t),$$

where p_n is one of an infinite number of roots of the equation $\chi(h) = 0$.

Then, if we could develop any other given function of s , say $\psi(s)$ in a series of the form $\Sigma \{ A_n (f p_n s) \}$, we could always determine D_n directly, supposing we knew the value of y when $t = 0$. But such expansions are not always possible, or at all events practicable.

$$\text{Roots of } \cos pa = -\frac{2}{e^{pa} + e^{-pa}}.$$

By trial and error, we find

$$p_1 a = 1.875 = \frac{15}{8} \text{ nearly (measure of } 107^\circ. 27'),$$

$$e^{p_1 a} = 6.521, \quad e^{-p_1 a} = .153,$$

$$\cos p_1 a = -.3, \quad \sin p_1 a = .954,$$

$$p_2 a = 4.69, \quad \cos p_2 a = -\frac{1}{55},$$

$$A_1 = .847 D_1,$$

$$\begin{aligned}
\text{and } y = & t_1 D_1 (.847 \sin p_1 s - 1.153 \cos p_1 s + .158 e^{\frac{15}{8} \frac{s}{a}} + e^{-\frac{15}{8} \frac{s}{a}}) \\
& + t_2 D_2 (1.01 \sin p_2 s - .99 \cos p_2 s - .01 e^{\frac{4.69}{a} s} + e^{-\frac{4.69}{a} s}) \\
& + t_3 D_3 \left(\sin \frac{5\pi s}{a} + \frac{1}{e^{\frac{5\pi}{2} \frac{s}{a}}} e^{\frac{5\pi}{2} \frac{s}{a}} + e^{-\frac{5\pi}{2} \frac{s}{a}} - \cos \frac{5\pi s}{a} \right) \\
& + t_4 D_4 \left(\sin \frac{7\pi s}{a} - \frac{1}{e^{\frac{7\pi}{2} \frac{s}{a}}} e^{\frac{7\pi}{2} \frac{s}{a}} + e^{-\frac{7\pi}{2} \frac{s}{a}} - \cos \frac{7\pi s}{a} \right),
\end{aligned}$$

$t_1, t_2, \&c.$ being abbreviations for the circular functions of t they represent,
+ &c. + &c. + &c.

If now we determine D_1, D_2, D_3, D_4 by the conditions that

$$\frac{d^2 y}{ds^2}, \quad \frac{d^3 y}{ds^3}, \quad \frac{d^4 y}{ds^4}, \quad \frac{d^5 y}{ds^5}$$

shall be the same in the statical curve

$$y = \frac{3}{2} \cdot \frac{\delta}{a^3} \left(as^2 - \frac{s^3}{3} \right),$$

and in the dynamical curve when $t = 0$, and at the origin $s = 0$, the 1st, 4th, 5th, 8th, and 9th differential coefficients will also be equal to each other and to zero in the two curves at the origin, so that the contact there will be of the ninth order. We shall find it unnecessary to determine D_3 and D_4 , they are so small as to be fairly omissible from any but an exceedingly close approximation. Hence we shall have

$$8.1 D_1 + 44 D_2 + 123 D_3 + 242 D_4 = 3\delta,$$

$$10.92 D_1 + 208 D_2 + 968 D_3 + 2662 D_4 = 3\delta,$$

$$50.2 D_1 + 10,630 D_2 + 234,700 D_3 + 1,771,000 D_4 = 0,$$

$$71.03 D_1 + 49,910 D_2 + 1,843,000 D_3 + 19,490,000 D_4 = 0;$$

$$\text{whence } D_1 = .42\delta,$$

$$D_2 = -.01\delta,$$

$$D_3 = .00028\delta, \text{ and may be omitted,}$$

$$D_4 = \dots\dots$$

$$ya, t = 0 = 2.307 D_1 - 2 D_2 + 2 D_3, \&c. = .99\delta \text{ nearly.}$$

Here where the error is greatest, it is scarcely perceptible.

The greatest value of $\frac{dy}{dt}$ is $3.5 \frac{b'}{a} \delta$ nearly.

Had we supposed the curve to have retained always its statical form, the greatest value of $\frac{dy}{dt}$ would have been only $\sqrt{8} \frac{b'}{a^2} \delta$.

$\frac{d^2y}{ds^2}$ will also, during the motion, attain to more than its primitive value.

If $p_2^2 bt = 7\pi$, $\frac{d^2y}{ds^2}$ will equal $-3.5 \frac{\delta}{a^2}$ nearly. This will be nearly the numerically maximum value of $\frac{d^2y}{ds^2}$ without regard to sign, and hence we see that a bent rod within the breaking limit at the centre may be broken by the rebound after it is set free, as $\frac{d^2y}{ds^2} = \frac{3.5\delta}{a^2}$ only at starting, and an addition of $\frac{1}{8}$ th to the strain might determine fracture.

The following is a table of values of $\frac{d^2y}{ds^2} (s = 0)$ for two successive values of t .

If $t = 0$, $\frac{d^2y}{ds^2} = \frac{3\delta}{a^2}$.

$p_1^2 b' t = 14^\circ. 22'$,	$p_2^2 b' t = 90^\circ$,	$\frac{d^2y}{ds^2} = 3.28 \frac{\delta}{a^2}$.
... = $28^\circ. 45' \frac{1}{4}$,	... = 180 ,	... = $3.34 \frac{\delta}{a^2}$.
... = $43^\circ. 7' \frac{3}{4}$,	... = 270 ,	... = $2.46 \frac{\delta}{a^2}$.
... = $57^\circ. 30' \frac{1}{2}$,	... = 360 ,	... = $1.43 \frac{\delta}{a^2}$.
... = $71^\circ. 52' \frac{3}{4}$,	... = 450 ,	... = $\frac{\delta}{a^2}$.
... = $86^\circ. 15'$,	... = 540° ,	... = $\frac{.6\delta}{a^2}$.
... = $100^\circ. 38'$,	... = 630° ,	... = $-\frac{.18\delta}{a^2}$.
... = 201° ,	... = 7π ,	... = $-\frac{3.5\delta}{a^2}$.

That the maximum value of $\frac{dy}{dt}$ is $\sqrt{8} \frac{b'\delta}{a^2}$ on the hypothesis of the deflected rod preserving, during the motion, the statical form due to the amount of displacement at its free end, may be thus shewn.

Let, as before, m be the mass of an unit's length and breadth of rod, R the reaction upwards at point $s = 0$. Then remembering the value of R , we have

$$m \int_0^a \frac{d^2 y}{dt^2} \delta s = mb' \frac{d^2 y}{ds^2}.$$

Now if δ be the extreme deflection at time t ,

$$y = \frac{3}{2} \frac{\delta}{a^3} \left(as^2 - \frac{s^3}{3} \right) \text{ according to hypothesis;}$$

$$\text{whence } \frac{d^2}{dt^2} \delta = - \frac{8b'^2}{a^4} \delta,$$

$$\text{and } \delta = \delta \cos \sqrt{\frac{8b'^2}{a^4}} t,$$

whence δ is greatest deflection, and the maximum value of

$$\frac{d\delta}{dt} \text{ is } \delta \sqrt{8} \frac{b'}{a^2}.$$

To determine the velocity of an arrow discharged from a bow.

Let ABC be the bow, B the centre, APC the cord, which is supposed perfectly flexible, and always stretched between the points AC and the arrow at P . If the bow be much

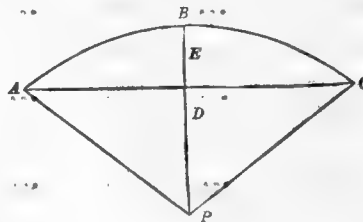

thicker at the middle than at the ends, which is usually the case, the amount of displacement of the centre of the cord P will be much more than twice that of the ends A, C . In a bow with which I experimented the displacement was very nearly four times that of the ends, and it will be assumed* that this ratio is constant during the motion.

Let then E be the initial place of P before the cord is displaced; AC perpendicular to BP ,

$$DE = x, \quad EP = 4x.$$

Let the depression of the centre of gravity of $AB = ex$, where e is a small fraction. e may be taken about .2 or .3 at the outside; .2 is, I believe, very near it in the bow I

* This assumption is only an approximation, for if E coincides with B , the limiting ratio of $DP : DE$ is $2 : \sqrt{3}$. But in a practical formula, regard must be had to quantities of the second and higher orders; and the ratio in the text is, I think, sufficiently near the truth to be adopted as the mean of the varying ratio of $PE : DE$.

employed. Of course when the displacement of the bow is considerable e is not constant, but it is nearly so.

The depression of the centre of gravity of AP is $\frac{5}{2}x$, and $EP = 4x$.

Hence if R be the upward reaction at B , m_1 the mass of AB , m_2 of AP , and m_3 of half the arrow, and if $2F$ be the force applied at P to stretch the bow, and R be assumed to vary as x , and δ be the extreme value of ED when the bow is fully bent, before the string is released, we shall have by first principles

$$(m_1e + \frac{5}{2}m_2 + 4m_3) \frac{d^2x}{dt^2} = - \frac{Fx}{\delta}.$$

Hence if V be the final maximum velocity of the arrow

$$V = 4 \sqrt{\frac{F\delta}{m_1e + \frac{5}{2}m_2 + 4m_3}}.$$

Ex. The unit of weight being 1 ounce, the accelerating force of gravity 32.2 feet per second, to find the velocity when $F = 200 \times 16\delta$, 9,

$$gm_1e = 5.5 gm_2 = 1,$$

$$gm_3 = .5 \text{ and } \delta = \frac{1}{4},$$

$$V = 4 \sqrt{\frac{200 + 4 + 32.2}{5.5 + 2.5 + 2}}$$

$$= 200 \text{ nearly.}$$

The greatest velocity I obtained was, I believe, about 215 feet, or, at the outside, 220 feet a second with a bow, each leg of which was 20 inches long; the stock in which it was set 2 inches broad; the breadth of the bow 1 inch, its thickness near the stock $\frac{1}{2}$ inch, and $\frac{1}{4}$ inch at the ends; the initial value of BE was 4 inches, and of PE 12 inches; $\delta = 3$ inches nearly. The steel was of the best "St Etienne," forged and worked with great care. A bow made of English steel, exactly similar, broke after using it some time, so I presume the steel is strained nearly to its breaking point, and $F = 200$ lb. probably. I may observe by the way that the strength of steel varies greatly, and that the best fine-grained steel is not nearly so well adapted for springs as a tougher and more irony steel. The velocities of the arrows I measured by means of sights; the depression for known short distances, combined with the range at 45° , enabled me very closely to calculate the velocity. The range at 45° gave the resistance of the air, which was sufficient to reduce in some instances the velocity 10 feet a second at 40 yards. A rough attempt at a Ballistic Pendulum, which I constructed, invariably gave the velocity too little, sometimes by as much as 20 feet a second.

Let $F = 80$, or $2F = 160$, $\delta = \frac{1}{2}$ foot, and the bow be of wood. An ancient English archer's bow probably "drew" as much as 160 lb., as even amateur archers use bows up to 100 lb. strength.

If the denominator of the formula = 5, which would be somewhat near its value, the whole string weighing about $\frac{1}{4}$ oz., and the arrow 1 ounce, $V = 250$ nearly. I suppose that 160 lb. would be, however, quite the limit of the strength of an archer's bow under any circumstances. V probably never exceeded 300 feet a second, and when we consider that a rifle-ball has an initial velocity of 1800 feet a second, it is easy to imagine how inefficient in comparison with our present weapons must have been those of our ancestors. The wonderful ranges said to have been attained by Robin Hood and William Tell are no doubt mythical. A curious fact concerning the possible amount of the velocity of an arrow is suggested by the formula we have last found, viz. that, supposing their material to be the same, any two bows of similar figure will impart the same maximum velocity, provided that the arrows and cords are also similar and proportional, that is to say, provided that their masses vary as the cube of the linear scale to which the bows are constructed. For, according to the received law of the strength of beams, &c. if F be the maximum strain a bow can support, k the breadth of the bow, and h its thickness at centre, and a its length,

$$F \propto \frac{kh^3}{a};$$

$\therefore Fa \propto kh^3 \propto$ the cube of the scale, and m_1, m_2, m_3 vary also as the cube of the scale;

$$\therefore \frac{Fa}{m_1 e + \frac{5}{2} m_2 + 4m_3} \text{ is constant.}$$

$$\text{If we had assumed } R = F \sin \frac{\pi}{2} \frac{a}{\delta},$$

Y would have equalled

$$4 \sqrt{\frac{\frac{4F\delta^3}{\pi}}{em_1 + \frac{5}{4}m_2 + 4m_3}}.$$

This assumption for the value of R , which is quite empirical, seems to agree more closely with the results of experiment, than the first assumed value, especially when the cord and arrow are light; and when in consequence the curve assumed by the bow in motion deviates more from its statical form than when the cord and arrow are heavier.

If we assume the law of thickness of a bow to be $Z = \frac{h}{1 + \frac{s}{a}}$, where h is the thickness

in the middle, or when $s = 0$, Z the thickness at any distance s from the middle, y will

$$= \frac{10\delta^3}{7a^3} \left(\frac{as^2}{2} + \frac{s^3}{3} - \frac{s^5}{10a^2} - \frac{s^6}{30a^3} \right)$$

to first approximation, and $e = .29$ nearly.

But a formula based on a first approximation only will not nearly express the real velocity when a bow is bent to the degree to which it is in practice.

I will conclude this paper with a short resumé of some of the more interesting results of experiment as to the range &c. of the bolts, and the general power of the steel cross-bow.

First, the "bolts" I used were of two kinds, either capped with iron cones, or with blunt leaden heads; the iron cones were about $2\frac{1}{2}$ inches long, and three-fourths of an inch broad at the base, the shaft was cylindrical, about 6 inches long, made of deal, and scooped out in such a manner as to leave three edges between the two ends. The iron-coned bolts penetrated from about an inch and a third to an inch and a half into sound deal planking. The weight of the bolts varied from about an ounce to an ounce and three quarters, and their flight was remarkably true. The greatest range of the blunt-headed bolts was about 240 yards at 45° , the iron-pointed ones would probably go 20 or 30 yards further; but as the only available ground I could find for my experiments as to range, was a portion of a public road I had measured, I thought it imprudent to launch pointed missiles upon it, at a distance such that persons might be passing, and yet not be visible to me.

With a weaker bow the difference was 15 yards in the range between the two kinds of bolts; the iron-headed bolt had a range of 150 yards, and the blunt-headed bolt only 135; the experiment in this case was attended with no danger, as the road was bounded by open fields on both sides up to that distance*. As far as I could judge by mere inspection, I should think the strongest cross-bow with which I experimented was at least as efficient a weapon as any I have seen among the numerous collection of ancient arbaletes preserved in the Musée d'Artillerie at Paris, and yet the velocity of a rifle-ball is more than 8 times the velocity of a bolt discharged from so powerful a bow as the one I possess.

The value of k the coefficient of resistance was obtained from the equation

$$\frac{d^2y}{dx^2} = -\frac{g}{x^2 \cos^2 \alpha} e^{2ky}$$

where for s I wrote

$$\left(1 + \frac{1}{\cos \alpha}\right) x \times \frac{15}{28}.$$

When $\alpha = 45^\circ$, this empirical approximation for s gives results of considerable accuracy; the approximation being much closer than can be obtained by taking several terms of the series for y , developed as in the books by Maclaurin's Theorem—at least it does so for the particular values of α and k which I had to deal with. For bolts of from 1 to $1\frac{1}{2}$ oz., k varied from $\frac{1}{800}$ to $\frac{1}{1100}$ and $\frac{1}{1200}$, when the bolts were not conical-headed. To determine the value of the other coefficients of higher powers of v in the expression for the resistance, no velocity less than that imparted by gunpowder is sufficient. In all cases k was found to be much greater than its theoretical value.

J. H. RÖHRS.

* The ranges of these two bows were afterwards increased to 260 yards and 180 yards respectively, for blunt-headed bolts, by using cords lighter than in the first set of experiments.

IX. *On a Metrical Latin Inscription copied by MR BLAKESLEY at Cirta and published in his 'Four Months in Algeria.' By H. A. J. MUNRO, M.A. Fellow of Trinity College.*

[Read February 13, 1860.]

'ONE of the most remarkable objects of antiquity which has been brought to light is a tomb of imposing dimensions on the south-west side of the city...On the fourth side [of the lower tomb] three sarcophagi are still lying. A fourth was taken from one of the niches, and on it is an extremely curious inscription, remarkable both for its portentous latinity and the blunders of the stonecutter in executing it. It is the epitaph of a Cirta banker who lived to the age of more than a hundred years etc.

I give the inscription exactly as it appears on the stone without any division of the words. There are eight unequal lines and two or three gaps:—

HICEGOQVITACEOVERSIBVSMEA*TADEMONSTROLVCEMCLARAFRVI
 TVSETTEMPORASVMMAPRAECILIVSCIBTENSILAREARGENTARI
 AMLXIBVIARTEMTYDESINMEMIRAFVILSEMPERETVERITASOMNISOM
 NISBVSCOMMVNISEGOCVINONMISERTVSVBIQVERISVSIVXVRIASEMPERFRVITVSCVN
 CARISAXICISTALEMPOSTOBTIVMDOMINAEVALERIAENONINVENIPVDICAEVITAMCVMPOTVI
 GRATAMHABVICVNCONIVGESANCTAMNATALESHONESTEMEOSCEN TVMCELEBRAVIFELICES
 ATVENITPOSTREMADIESVTSPIRITVSINANIAMEMPRABELIQVATTITVLOSQVOSLEGISVIVVSMEE
 MORTIPARAVIVTVVOV'EQREVNAMNO'AMEDESERVITIPSASEQVIMINITALESEIICVOSEXOLECTOVENITAE

The old gentleman probably intended to write: Hic ego qui taceo versibus mea fata demonstro, lucem claram fruitus et tempora summa. Præcilius, Cirtensi Lare, argentariam exhibui artem. Fides in me mira fuit semper et veritas omnis omnibus communis. Ego cui non misertus ubique? Risus, luxuriam semper fruitus cum caris amicis, talem post obitum Dominae Valeriae non inveni. Pudice vitam cum potui gratam habui cum conjuge sanctâ. Natales honeste meos centum celebravi felices. At venit postrema dies ut spiritus inania membra relinquat. Titulos quos legis, vivus meæ morti paravi ut voluit Fortuna. Nunquam me deseruit ipsa. Sequimini tales: hinc vos exspecto. Venite.'

BLAKESLEY'S *Four Months in Algeria*, p. 283.

I subjoin at once the above inscription arranged in verses. The nature of these singular verses it is the purpose of the following paper to elucidate.

1. Hic ego quitáceo vĕrsibus meā vītā dĕmōnstro
2. lácĕm clára frúitūs ettĕmpora súm̄ma. Praēcĭl(iu)s
3. Cirtĕnsi lārĕ ārgĕntār(ia)m ěxĭbuĭ ārtĕm.
4. fŷdĕs ĩnnĕ mĭrā fŷit sĕmper ětvĕritās ómnis.
5. ómnibŷ commŷnĭs ěgo cui nŷn̄misĕrtus ubiq̄ue?
6. rĭsŷs, lŷxŷr(ĭa) sĕmper frúitus cuncárĭs amĭcis,
7. tálĕm pŷst(ŷbit)ŷm d(ŷmin)ae Vālĕr(iae) nŷn̄ĭvĕnĭ pudĭcae.
8. vĭtam cŷm pŷtui grātām hāb(ui) cŷncŷnjuge sánctam.
9. natáles hŷnĕstĕ m(ĕo)s cĕntŷm c(ĕle)brāvĭ fĕlĭces.
10. át v(ĕnit) pŷstrĕma d(fĕs) utsp(ŷrit)us inánia mĕmpra relĭnquat.
11. tĭtulŷs quoslĕgis vĭvus mĕĕ mŷrtĭ parāvĭ,
12. utvŷluit fortŷna: nŷn̄quam mĕdĕsĕruit ĩpsa.
13. sĕquĭmini táles: hĭnc vŷs ěpĕctŷ. venĭtae.

v. 12. *Perhaps* utvolui: fortuna nāmnŷn, etc.

WHEN I read Mr Blakesley's book last autumn, this inscription at once attracted my attention. On examining it I saw, as indeed its author tells us, that it was verse, and verse of some importance as a landmark in the history of the Latin language. Not long before that time I had been reading the two poems of Commodian, an early African Bishop, of whom I will presently say more. They, as well as our inscription, are composed in what is intended to be hexameter verse, verse that is to say written by men of some education, who lived however at a time when that most extraordinary change had already taken place in Latin, and probably also in Greek. I allude to the loss of quantity which was the very bone and sinew of the old language, and to the consequent revolution in the nature of the accent which then degenerated and hardened into a mere stress, resembling the Italian or German or English accent. Of course in the schools of Italy, Gaul and Spain the knowledge of the old quantity was maintained, just as it is in England at Eton or Cambridge; but the poems of Ausonius and Claudian are in all essential points as artificial an imitation of Virgil or Horace, as the Musae Etonenses or the Arundines Cami. As prosody therefore and the writing of nonsense or sense verses appear unfortunately to have been quite neglected in the schools of Africa, a worthy Bishop or rich banker, like Commodian or Praecilius, read Virgil by accent alone, and in attempting to imitate him set to work in much the same way as a modern Roman or Englishman would do, who had made himself in other respects a good Latin scholar, without having learned the rules of Prosody: rules which swineherds in the

days of Homer and ploughmen in those of Plautus had imbibed with their mother's milk and could discriminate with the nicest precision.

As soon as I had seen it too, I looked for an acrostich. The habit of writing acrostichs is very ancient in some kinds of Latin poems. Cicero in the *de divin.* II, 54, tells us that the Sibylline verses and some of the poems of Ennius were so composed. Commodian's longer poem, the *Instructiones*, containing more than 1200 verses, forms eighty sections, each of which is an acrostich, and denotes its title by its initial letters. The last section of all, read backwards, gives *Commodianus Mendicus Christi*. In the second line of our inscription we find *Luc. Praecilius* plainly enough, and the initial letters of the last ten compose the word *Fortunatus*. Perhaps the initial letters of the first three verses H. L. C. may stand for *hoc loco cubat*, or *conditus est*, or *hunc locum consecravit*, or *hunc lapidem condidit*: these or similar expression being common enough in epitaphs. It is no wonder then that, cramped by the requirements of metre and the necessities of the acrostich, the style is somewhat stiff and crabbed. Yet the Latin, making the due allowances, is not bad or ungrammatical, and is very superior to many inscriptions of a late date. Indeed it is very much better than Commodian's, and gives in my opinion a far correcter representation of this kind of verse. Of the two poems of Commodian the one I have just mentioned has often been printed, but always after one very corrupt manuscript, and is therefore in many parts mutilated and imperfect. The other poem was first published a few years ago by Dom Pitra in the first volume of his *Spicilegium Solismense*, and is still more corrupt than the former. For this, as well as other reasons, our inscription is a more trustworthy representation of this style of verse.

Commodian is supposed by Cave and Dodwell, whose opinion has been generally acquiesced in, to have written about A.D. 270. Dom Pitra in his introduction to Commodian's second poem places him as early as 250. Clinton in his *Fasti Romani*, Vol. 2, p. 450, puts him more than a century later, for the following reasons: 1. Jerome who wrote in 392 makes no mention of him in his catalogue. 2. Gennadius who wrote in 493 places him after Evagrius who lived in 388, and after Prudentius who lived in 400. 3. Gennadius observes that he followed Lactantius, and Lactantius lived in the reign of Constantine. The first two reasons seem to me of no weight. Jerome passed over many more important writers; and the work of Gennadius, Presbyter of Marseilles, was intended as a mere supplement to Jerome; so that Commodian would have a place in the one list, because he was excluded from the other. Gennadius observes, so far as I can see, no chronological order whatsoever. Audentius, a Spanish Bishop, who comes immediately before Commodian in the list, is placed by Cave, I know not how rightly, in the year 260. Honorius merely repeats Jerome and Gennadius. The third argument would have more weight, if we suppose that Gennadius wrote with accurate knowledge of those times. But proud of his own Gallic culture, he speaks of Commodian as a worthy man, but talks contemptuously of his 'quasi versus'; and says 'Tertullianum et Lactantium et Papiam auctores secutus', 'he followed the doctrines of Tertullian etc.'; meaning merely, I presume, that there was a resemblance between Commodian and these fathers. Now Tertullian he certainly did follow; but no two styles can be more different than those of Lactantius and Commodian. I cannot there-

fore think that this vague expression of Gennadius is sufficient to outweigh the strong internal evidence that Commodian lived in the days of persecution, at the very latest in the beginning of the fourth century.

I should be inclined to infer that our inscription was of about the same date. Praecilius speaks of his Cirtensian home. Now Cirta, the old capital of Numidia, was very flourishing in the third century. During the civil wars of the fourth century waged by Constantine and his rivals it fell into entire decay, and was rebuilt by him under its present name of Constantina. If Praecilius had written after these events, he would perhaps have given the city its new name; and besides this a wealthy banker of all men would have been least likely to have enjoyed the uninterrupted peace of mind and outward prosperity of which he speaks so feelingly.

To Mr Blakesley's copy, followed by his explanation, I have appended my own arrangement of the verses with the accents, and the quantity marked where it differs from the true prosody. Of course Praecilius himself did not know what the quantity was. His verses are a mere reproduction of his own idea of what those of Virgil were, read by him according to accent. But this shall presently be explained at greater length. I wish first to say a few words about the Latin accent generally; next to shew that before the third century Latin verses of every kind, popular as well as learned, were written by quantity alone; that on the different kinds of metre accent had no direct influence at all; that however sometimes consciously, sometimes unconsciously, certain poets sought sometimes a coincidence, sometimes on the other hand a contradiction between the *ictus metricus* of the verse and the accent; that in the course of the third century by some extraordinary degeneracy of the language, accent began entirely to supersede quantity which practically became a dead thing and was kept up only by artificial training, and that this led necessarily to the destruction of the old language and to the formation of its daughters the modern Romance languages; that nearly about the same time the same strange change came over the Greek and occasioned its total disorganisation, and that it was owing to the utter effete-ness of the learned at Constantinople and the absence of national life in the people, that the Romaic could never extricate itself like the Romance languages, but always had and still has to struggle with a dead, spurious, abortive Hellenic. Having touched on these topics as briefly as possible, I will conclude with a special comment on each line of our Inscription.

The rules of the Latin accent may be told in a few words. Like the Greek, it had no relation to quantity or the length of the syllable, but was a mere *raising or sharpening* of the tone of voice at the syllable on which it was placed. As in Greek too, there was both a circumflex and an acute; every independent word had one of these two accents. All the unaccentuated syllables were supposed to have the grave accent. Whether the rules of the Greek and Latin accent were ever different from what we know them to have been in historical times, more resembling for instance that of their common sister the Sanscrit, I shall not stop to enquire. Within the records of history the two had this in common, that the accent could never go farther back than the third syllable from the end of the word. It is an instructive fact, that Cicero, who knew only his own language and Greek, in the *Orator*, 18, declares it to be inconceivable that this should not be so. 'Nature herself', he says, 'has so

modulated the speech of man, as to place on every word one acute tone, and not more than one, and that one not beyond the third syllable from the end.' In modern times many have found it impossible to conceive what he thinks it impossible not to conceive. Such creatures of habit are we. As to the limits within which the accent might range, the two languages are agreed; as to the place it might have within these limits they differ greatly. In words of more than one syllable, with few and peculiar exceptions, the Latin accent was never on the last syllable. In this respect it departed widely from the other Greek dialects, but agreed curiously with the Aeolic, with branches of which dialect in Italy the Latins were so long in contact. But in another and even more important point the Latin was in direct opposition to the Aeolic, as well as all other Greek dialects. In Greek the length of the last syllable limited the range of the accent; the length of the penultimate made no difference whatsoever. In Latin polysyllables the length of the last syllable was quite unimportant; the length of the penultimate absolutely determined the place of the accent. If it is long, the accent must be on it, if short, it cannot be on it. To give a few examples.

Monosyllables in which the vowel was long by nature, were circumflexed; as *sól*, *ros*, *mos*, *pons*, *mons*, *res*, *os* (*oris*), *est* ('eats'). Those in which the vowel was by nature short, were oxyton; as *mél*, *cor*, *vir*, *mors*, *nux*, *os* (*ossis*), *est* ('is').

Dissyllables, the penultimate of which was short or only long by position, were paroxyton; as *árma*, *virum*, *vēnit*, *deos*, *esse* ('to be'), *essent*, *lectus* ('bed'). Those in which the penultimate was long by nature, if the final syllable was also long either by nature or position, took the same accent; as *órís*, *fato*, *Romae*, *celant*. But if the last syllable was short, the penultimate was circumflexed; *prímus*, *vēnit*, *iram*, *musă*, *lectus* (particip.).

Polysyllables, if the penultimate was long either by nature or position, had the accent on that syllable; and whether that accent was a circumflex or acute, was determined by the same rule as in dissyllables: *regína*, *adire*, *pietate* took the circumflex; *inférret*, *Albani*, *labores* the acute. If the penultimate was short, all polysyllables, whatever the quantity of the antepenultimate or of the last syllable, were proparoxyton; as *Itáliam*, *profugus*, *litora*, *caelestibus*, *asperrimi*.

The following are exceptions to these general laws. The enclitics *que*, *ve*, *ce*, *ne* attract the accent to the syllable immediately preceding, whether long or short: *armáque*, as well as *armisque*; *illáve*, *istóce*, *sicíne*. When *ce* and *ne* suffer apocope, the accent is then on the last syllable: *illúc*, *adhúc*, *istóc*, *audín*, *vidén*, *tantón*, *crudelín*. In a few other cases too the accent is on the last syllable, as in *nostrás* ('of our country'), *vestrás*, *cujás*, *Antiás*.

The atonics as they are called, that is words so closely joined with another that they become as it were a part of it and lose their own accent, are much more numerous in Latin than in Greek; comprising all the prepositions, many conjunctions, and the relative, not the interrogative, *qui*, *quae*, *quod*. Particles too are often joined enclitically to the word preceding them. Quintilian quotes from the first line of the Aeneid *quiprímus abóris*, where both *qui* and *ab* are atonic, that is to say really form but one word with *prímus* and *oris* respectively. An ancient Latin seems to have been able by the sense alone to distinguish *in justo* from *injústo*; or *praeter míssa* from *praetermíssa*, even dissyllabic prepositions being atonic. Of *circum litora* Quintilian says that some grammarians taught that *circum*, like the Greek

dissyllabic prepositions, had an accent on the last syllable. But his ear, he says, could detect no trace of one. Yet many of the later grammarians appear to have held this theory, so frequent are their allusions to it. We may safely infer from inscriptions, the oldest manuscripts, the ancient Grammarians and other sources of information that there were hundreds of cases in which writers felt themselves at liberty to unite two or more words into one or to keep them separate. *Qui cumque* or *quicumque*, *ubi cumque* or *ubicumque*, *magno opere* or *magnopere*, *ni mirum* or *nimirum* are a few instances out of many. Some other exceptions to these general laws will be noticed in the course of this paper.

It appears from what has been said that we English in reading Latin place the accent generally, but by no means always, on the proper syllable. But then we have entirely changed its nature, making it a mere stress, instead of a simple raising of the tone without any lengthening of the quantity. And Praecilius and his contemporaries already did the same. From them and their still more degraded descendants the Italians and other western nations inherited this debased accent which had overthrown and usurped the rights of quantity. In the second line of the Aeneid we read *Itáliam fáto prófugus* with the accent on the right syllable; but on the same principle we ought to say, and Praecilius indeed and the Romans for centuries after him did say, *Lavináque*. We flatter ourselves that we thus preserve the quantity; but that is a mere delusion. It we feel by a mere mental process. Whether we pronounce *prófugus* or *profúgus*, quantity is equally violated. In the same way we read Greek with this debased Latin accent, and fancy that we preserve the quantity while sacrificing the accent. The modern Greeks read old Greek with the ancient Greek accent debased in the same way into a mere stress. We think them, they think us in the wrong; and in different ways we are both equally in the wrong. *Μήνιν αείδε θεά* in an English or Italian and *μήνιν άείδε θεά* in a modern Greek mouth are equally remote from the accent and quantity given to the words by Homer or Demosthenes.

The thing is so manifest, it would be a waste of words to prove that while Greek was a living tongue, metre was determined by quantity alone, and that accent had no influence on it direct or indirect. In Homer or any other poet verses may be found with identically the same cadence, flow and structure, in one of which the accent shall in every foot agree; in another shall in every foot disagree; in a third shall sometimes agree, sometimes disagree with the metrical ictus. But in prose as well as verse quantity was of far more importance than accent. This is attested by every technical writer on the subject, from Aristotle downwards. In the third book of his Rhetoric he gives elaborate directions about the rhythms suitable for the different styles of prose, whether it be an iambic, trochaic, dactylic or paeonic rhythm; but says not one word of the accent. With Dionysius too accent was quite subordinate. The due proportion and due admixture of long and short syllables were all-important.

Nearly the same may be said of Latin. Their poetry from the most ancient recorded times was purely quantitative; the old Saturnian verses quite as much so as the Aeneid. And in prose too quantity was far the more important element. Cicero and Quintilian attest this as decidedly as Aristotle or Dionysius. The notion of an old *lingua rustica* in which the people

composed accentual verses in contradistinction to the quantitative poetry of the learned, is a delusion, a chimera, borrowed not from the fresh youth of the language, but from its anile decrepitude. That in one sense there was a people's language, that peer and peasant did not speak precisely alike, is a truism. But in that sense the language of Cicero's orations is different from that of his letters, and both from that of Plautus. There was not even a *lingua rustica* to the same extent that there must have been in Greece, when Attic became predominant and the other dialects sank into patois; or that now prevails in England where among many different dialects one has been for centuries the universal language of literature and refinement. As in the present day the ploughmen and herdboys of the Alban and Tusculan hills, the head-quarters of the old Latin race, speak the pure *lingua Toscana* with the pure *bocca Romana*, so in old times the whole 'Latinum nomen' spoke the Latin undefiled of Plautus and Terence and Cicero and Caesar. In historical times the closely allied Umbrian and Oscan and Sabellian always remained distinct languages, and never degenerated into mere patois of the Latin. An accentual verse without quantity could have had no meaning to an old Latin ear; for the accent was no stress. Ennius did much for the artificial Roman verse; but that he invented quantity is as true as that Dante invented the Italian language. We still possess many fragments of Livius Andronicus who represented his first play before Ennius was born. I believe indeed that accent had a greater, I will not say direct, but indirect influence on the verses of Lucretius and Virgil than on those of Livius Andronicus and Naevius.

While the language was uncorrupted, the accent had no power, no tendency to lengthen a syllable. To give a single illustration of this: The highest authorities declare that in the whole of the old dramatic poetry there is no instance of a short vowel being lengthened before a mute and liquid; thus *patres, patribus, patrius, lacrimae, agros, indugredi*, have the accentuated syllable always and necessarily short. The learned poets in imitation of the Greeks allowed these syllables to be common; and they used indifferently *tenēbrae* or *tēnebrae*, *lātebrae* or *latēbrae*, changing the accent with the quantity. Nay Ovid even ventures, though only once, to write *nunc similis volucris, nunc vera volucris* in the same line.

Most languages when allowed their free development have shewn a tendency towards contraction. This was seen for instance in the passing of Ionic into Attic. It was eminently characteristic however of the Latin. The author of the Varronianus well observes 'that one could not better describe the genius of the Latin language than by defining it as a language which is always yearning after contraction.' The various modes in which this tendency developed itself may be seen in that and other learned works. When we first become historically acquainted with the Latin Language in the oldest extant inscriptions, this tendency, especially in regard to the suppression of final letters and syllables, had been carried to such an extent as to endanger the conjugations, declensions, and consequently the syntax, nay the very existence of the language. Thus we find *dedro*, for *dederunt*: first the final *t*, then the *n* having fallen away. Nay Mommsen, one of the highest authorities on such a subject, has lately proved the existence of *deda* (for 3rd pers. plur. perf. ind.); that is to say *dedanti*, the same form as the Greek *πεφύκαντι*, had become successively *dedant, dedan, deda*. Then as to the declensions, we find many instances in the oldest inscriptions where the final *s* or *m*

has been suppressed; so that *Cornelio* stands equally for nominative, dative, accusative and ablative. But probably on the whole the changes which had taken place up to this time were beneficial. As we know it, the Latin compared with the Greek labours with an undue proportion of long vowels and accumulations of consonants. And had its forms been stereotyped by a learned literature much sooner than they were, rhythm would have been almost swamped under the dead weight of ponderous long syllables. *Musa* the nominative would have been as long as the ablative. When the language then had probably reached the proper stage of development, perhaps *because* it had done so, there arose a succession of great and brilliant writers, Naevius, Plautus, Ennius, Terence, Pacuvius and others; who fixed the grammar and prosody of the language, and made it what it was and is, one of the master languages of the world. But these writers, proceeding all of them of course on the basis of quantity, the only one which could have had any meaning to them or their hearers, fixed this quantity in certain cases, according to the style of verse they were writing, on different principles. Ennius, in introducing from the Greeks the learned hexameter, observed stricter rules of prosody than he did in his tragedies and satires, and than did his predecessors or contemporaries Naevius, Plautus and others. Of course the Greek and Latin poets alike, in order to have a definite metre, are obliged to divide syllables into long and short, and to say that all long and all short shall be of the same value respectively, and that every long syllable shall be twice the length of every short. Yet all long syllables and all short syllables are not in reality of exactly the same lengths respectively. There are also many doubtful syllables which may at pleasure be either long or short. When then a syllable had become decidedly and indisputably short, as the final *e* in *bene* and *male*, though originally long, Ennius in his hexameters determined it should be short; but he would not suffer the *e* in *probe* to be so. Thus also he allowed *dederunt* and *dedere* to remain side by side, though the final syllable of *darent* was made irrevocably long. He wrote at pleasure *magnus* or *magnum*, but he in no case would permit the last consonant in *pater* or *datur* to be neglected. His rules, with only slight modifications, were observed through the whole flourishing period of Latin literature and gave to the learned poetry a finish and precision which it could not otherwise have had. And to attain this end he sacrificed much. For a large proportion of the noblest words and forms in the language were thus altogether excluded from the hexameter: all the innumerable cases for example where a short vowel came between two long ones. Ennius on the other hand as tragedian and satirist, Naevius, Plautus and others constructed their verses on the same essential principles of prosody, but gave a far wider latitude to doubtful syllables. Thus not only were *bene*, *male* short, but *probe* might be, though it was not necessarily so. Again *pater*, *datur*, *darent*, and hundreds of similar forms might have their full metrical value, or the final consonants might be slurred over and neglected, as in *scripsere* for *scripserunt*. We must not suppose however for a moment that *pater* could be a monosyllable, a sound impossible for an old Roman tongue. The French *père*, like *mère* and *frère* arose in a widely different way.

Even in the middle of many common words position might be neglected, and *voluptatem* might have the second syllable short, although it as often has its full metrical value. So in many prepositions, conjunctions and adverbs, *ad*, *in*, *enim*, *quidem* etc., the last consonant might at pleasure be suppressed or not; and in hundreds of words like *domi*, *manu*, *sequi*,

the last vowel might be either long or short. Again *meus, tuus, boves*, and many other words might be either dissyllables or monosyllables.

But I cannot dwell longer on this wide question which has been so fully developed by Ritschl, the highest authority on the subject. In one of the last numbers of the Rhenish Museum that scholar gives some hexameters written according to the rules of the dramatic poets probably between 600 and 650 v. c., and interesting in many respects. They generally go by the name of the *Praenestinae sortes*. Here are one or two of them :

Non sumus mendacis, quas dixi; consulis stulte.

This verse might have been written by Ennius or Lucretius who ends a line with *pendentibus structas*.

Conrigi vix tandem, quod curvom est, factum crede.

Here the *i* in *conrigi* is short, as it might be in Plautus. Yet the principle of quantity is not departed from, any more than it is by Virgil or Horace, when they use *mihi* or *ubi* long or short at pleasure.

Quir petis postempus consilium: quod rogas non est.

Quod petis is simple enough; *consilium* has the quantity given to it once by Horace; *rogas* with the last syllable short is found in Plautus and Terence, and is no more a violation of quantity than *amät*, the last syllable of which was originally as long as *amas*; and to Plautus and Ennius was still common, long or short indifferently. Here is one more instance :

Est equos perpulcer, sed tu vehi non potes istoc,

which admits of just the same explanation.

I have dwelt thus long on this part of my subject, in order to protest against the absurdity of supposing that quantity was any less the principle of the old, than of the Augustan Latin poetry, and of imagining that the accent, then a mere heightening of the intonation, could have determined its laws.

But in genuine Latin verse was there any coincidence, or any contradiction, intentional or unintentional between the accent and the metrical ictus or arsis, as it is called, of the verse? Three of the very highest authorities on such a question, Bentley, Hermann and Ritschl, have all asserted that the old dramatic poets intentionally sought an agreement between accent and ictus in their iambic and trochaic verses, especially in the middle, the most important part of the verse; while the learned Augustan poets aimed at nothing of the kind. This assertion with respect to the dramatic writers has recently been denied and in great measure explained away; and it seems clear that those scholars to some extent mixed up their feeling of the English or German accent or stress with their conception of the Latin accent. But I must say a few words on this subject, as I wish to shew that the influence of the accent is on the contrary more perceptible in the Augustan and later poets, than in the earlier; as indeed I should a priori have rather expected, considering the way in which it finally superseded and extinguished the old quantity.

The nature of the Latin accent must always be remembered; that which in contrast to the Greek Quintilian complains of, its stiffness and monotony (*rigor et similitudo*); the fact that almost every word in the language was barytone, and that, when the penultimate was

long, the accent was almost invariably upon it. This alone would often according to the nature of the verse cause either an agreement or disagreement between ictus and accent.

Thus in the old Saturnian verse it is difficult to avoid a frequent coincidence between the two, at the end of the first half, and throughout the whole of the second half of the verse. But this coincidence certainly was not sought. Take the often quoted line, as simple a form as you can have of the verse,

Dabunt malum Metelli—Nævio poetæ.

In the two first feet ictus and accent disagree; in the next from the nature of the Latin accent they agree. Take again this line from the tomb of the Scipios,

Cosol Cesor Aidilis—qui fuit apud vos.

Here, as *qui* and *apud* are atonic, it happens that five times accent and ictus disagree, and only once coincide. And so in many others of the best known verses, especially in those of the great master of the Saturnian metre, Nævius, the poet would appear almost unconsciously to have striven against the coincidence of the two.

Immortales mortales—si foret fas flere
Flerent divæ Camenæ—Nævium poetam.

In the first of these verses, since *si* is probably atonic, we have four contradictions, only two agreements between ictus and accent. Yet had the words been thus arranged: *Ædilis Consul Censor* etc. and *Mortales immortales* etc., coincidences would have been much more numerous.

Let us now examine the hexameter and iambic.

With that unerring instinct which never failed them the old Greeks at a particular stage in the development of their language invented the heroic hexameter, the noblest and most perfect metre of the noblest and most perfect of languages. In that verse, for some reason or other which every one can feel, but I for one cannot explain, the caesura was the central force which bound the two parts together, gave to them all their beauty and significance, and allowed an almost infinite variety of rhythm; by the judicious application of which poems of any length might be constructed without their ever palling or wearying the reader. Without this caesura the verse would be an inorganic unrhymical mass. As the language changed its forms, the different dialects developed different forms of verse, all exquisite in their kind. In Athens the drama occupied the place that the old epic had filled in Ionia: and as suitable alike to it and the dialect in which it was written, the iambic senarius was happily selected as the principal metre. In this verse too the caesura is the central force which gives it a variety of cadence, almost rivaling the heroic, and rendering it equally suitable for long poems. On the whole therefore, though it is inferior in sweetness to some of the lyric metres, it may be looked upon as only second to the hexameter. Considering the nature of the Greek accent, any influence of it upon these or other Greek metres is quite out of the question. It is only an Eustathius, living when the language was prostrate, who could suggest that the second syllable of *Αἰόλου*, which he met with in his Homer, was long on account of its accent, never asking himself, why he did not find *Αἰόλω* the dative so used, and ignorant that Homer really gave the form *Αἰόλοφο*, another form of *Αἰόλοιο*; and that *ἀνεψιῶν* is used with the same quantity.

From the Greeks the Latins borrowed these two metres, and feeling that the right obser-

vance of the caesura was all-important, they on the whole applied it even more strictly than their masters. The ordinary caesura therefore falling in the middle of the third foot, it has been argued, in opposition to Bentley's and Ritschl's notion of an intentional coincidence between ictus and accent in that part of the iambic senarius and trochaic septenarius, that from the nature of the Latin accent this could not fail to be generally the case, and that if you read Aristophanes or Euripides with the Latin accent you will find it to apply to them as much as to Plautus or Terence; and they at all events intended no coincidence between their own ictus and the Latin accent.

Take the fifth line of the Mercator of Plautus :

Graece haec vocatur Emporos Philemonis.

From the nature of the accent in *vocatur Emporos*, it corresponds with the ictus. Yet though Ritschl and Bentley have pushed their idea of an intended coincidence much too far, from a somewhat mistaken notion perhaps of the true nature of the ancient accent, I cannot help seeing even in Plautus and Terence an unwillingness, though probably only half conscious unwillingness, to allow in certain cases ictus and accent to be in violent opposition. Take the next line to what I have just quoted,

Eadem Latine Mercator Macci Titi,

where in the word *mercator* accent and ictus are in direct contradiction to each other. Such verses as these occur not unfrequently in Plautus, and though I think they are rarer in Terence, we meet with them occasionally in him also. Now when we reflect that a spondee occurs as frequently in the fourth as in any other foot of the verse; and yet that we find perhaps twenty instances where accent and ictus are in opposition in the fifth foot, as in the first verse of this play,

Duas res simul nunc agere decretumst mihi,

for one instance similar to that just quoted,

Eadem Latine Mercator Macci Titi,

it would seem clear that this latter rhythm was intentionally avoided by Plautus and Terence, and that the accent alone can explain why this was done. I am likewise led to this conclusion by what I am now going to shew, that this connexion between ictus and accent gradually established itself much more firmly in times when quantity was yet in possession of all its rights, and probably contributed much to the eventual supplanting of quantity by accent and the consequent destruction of the language.

In the exquisite pure iambic odes of Catullus ictus and accent must from the necessity of the case coincide in the middle of the verse. At the beginning and end he probably neither sought nor avoided such coincidence and wrote with equal satisfaction

Senet quiete seque dedicat tibi

and

Gemelle Castor et gemelle Castoris

and

Quis hoc potest videre, quis potest pati.

In the first of these verses accent and ictus disagree in the first and last foot; in the second

they agree throughout; in the third they disagree in almost as many places as they well could in this kind of verse. Yet led by his own delicate instinct he makes them coincide in far the greater number of lines in the ode from which the last verse is quoted:

Mamurram habere quod comata Gallia
 Habebat ante et ultima Britannia.
 Et ille nunc superbus et superfluens
 Perambulabit omnium cubilia
 Ut albulus columbus aut Adoneus.
 Eone nomine, imperator unice,
 Fuisti in ultima occidentis insula,

and so on.

Decimus Laberius, the famous writer of mimes in the time of Augustus, entirely I believe avoids in his extant fragments such verses as the sixth line of the Mercator of Plautus quoted above, though he rather seeks than avoids such a cadence as this,

Non me flexibilem concurvásti ut carperes.

Read *concurvas* and observe the change of rhythm with the change of accent.

This increasing tendency (for of such tendency I feel no doubt) to make accent and ictus agree would be most likely to be perceived in verses written to please the popular ear. Dom Pitra in his valuable preface to the poem of Comodian (p. xxiv.) speaks of his verse as written in rhythm; then quotes Bede's definition of rhythm, 'verborum modulata compositio, non ratione metrica, sed numero syllabarum ad iudicium aurium examinata, ut sunt carmina vulgarium poetarum'; and then gives as a good example of this rhythm the celebrated *scommma*, sung by Caesar's soldiers during his triumph in the usual scoffing style employed to avert the envy of the Gods:

Gallias Caesar subegit, Nicomedes Caesarem,
 Ecce Caesar nunc triumphat qui subegit Gallias;
 Nicomedes non triumphat qui subegit Caesarem.

He then observes that such like plebeian verses without metre were even more usual among the Greeks than the Romans. In all this he is strangely mistaken. Bede who wrote centuries after the downfall of quantity, means by his rhythm the accentual Church hymns, such as those attributed to St Ambrose whom he quotes. In classical times of course rhythm both with Greek and Latin writers meant simply the several proportions and arrangements of long and short syllables; definite sections of which formed the several metres dactylic, iambic, etc.; and has nothing in the world to do with accent. Caesar's veterans were incapable of perpetrating a false quantity. Their verses are in as strict accordance with the laws of prosody as the *Aeneid*. Yet in every instance with a single exception in the first line accent and ictus are in agreement. In this specimen we have trochees in all the odd places; but from other examples of the same kind we know that, as in the comic metres, every foot except the last might be a spondee. Observe this other *scommma* sung by Caesar's soldiers:

Urbani, servate uxores moechum calvum adducimus.

Here accent and ictus are in opposition in the first two feet, but in the middle and end are

quite in accordance; and we feel that this ought to be so. We might read for instance the second of the verses above quoted, thus:

Ecce Caesar nunc triumphat qui devicit Gallias.

But we feel that

Ecce Caesar nunc triumphat devicit qui Gallias

would be inadmissible, though that would give precisely the same rhythm for the fourth foot which we had in the verse before quoted from Plautus:

Eadem haec Latine Mercator Macci Titi.

Such progress in popular poetry had the desire of agreement between accent and ictus already made. In the song of Galba's soldiers a century later,

Disce, miles, militare; Galbast non Gaetulicus,

quantity is accurately observed, but accent agrees with ictus in every place, and we feel that such a rhythm as

Disce, miles, militare; Gaetulus non nunc adest

would not have been tolerated.

That the popular taste for this agreement between accent and ictus was already very decided, may I think be inferred no less certainly from its ostentatious avoidance by a learned writer of iambs. I allude to the tragedies of Seneca. He is most strict in his observance of the regular caesura; and this, as he always has iambs in the even places, necessitates an agreement between accent and ictus in this place. If then he concluded the verse with the same kind of fall as *Nicomedes Caesarem*, the writer must have felt that he would be conforming himself to the vulgar taste, and therefore in the fifth foot of his verse which, if not always, is almost always, a spondee or anapaest, he contrives that ictus and accent shall be *nearly always* in violent opposition. The *Hercules Furens* thus opens:

Soror Tonantis, hoc enim solum mihi
Nomen relictum est, semper alienum Jovem
Ac templa summi vidua deserui aetheris,
Locumque, caelo pulsa, paelicibus dedi, etc.

In the eleventh line we first come to an apparent exception, but only an apparent one which really proves the rule.

Passim vagantes exerunt Atlantides,

where *Atlantides* is a Greek word and accentuated on the penultimate; and we know from Quintilian (and the unanimous statements of the later Grammarians confirm what he says) that in the time of Seneca the Romans, when they adopted Greek words, always gave them the Greek accent, though Quintilian adds that he remembers when a youth that the most learned old folks pronounced such words, *Atreus* for instance, with the Latin accent. Indeed in looking through a good deal of Seneca, I have been surprised to find how many of the apparent exceptions consist of such Greek words. At v. 495 of the same play,

Umbrae Creontis et penates Labdaci,

I came to the first instance of a cadence like *Nicomedes Caesarem*; and here too *Labdacus* is a Greek word. Now such cadences must from the nature of the Latin language have presented themselves to him in almost every line, had he not purposely avoided them. When he ends a verse with a word like *aetheris*, he keeps ictus and accent separate by most violent elisions. *Deserui aetheris, promissa occupet, imperia excipit, devicti intuens*, all occur in the first few lines of one play. This is the more striking, since in the other parts of the verse he but rarely elides long vowels. Very striking too it is, when we think of the following fact. The older poets were free in their elision of long vowels; and Virgil produces many of his most exquisite effects of harmony by its judicious employment. But when we examine Ovid's *Metamorphoses*, we find that he confines such elisions within very narrow limits, and so does Seneca's contemporary Lucan; and the philosopher Seneca (and I see no reason why he and the Tragedian should not be one and the same person) in the few hexameters which he scatters through his prose works entirely abstains from the elision of long vowels.

I cannot help comparing the mode in which Seneca sought to avoid in his iambics the favourite popular movements, with the course pursued by two greater poets than himself. Euripides adopted in his later plays a style entirely different from that of his earlier, seeking no doubt by a freer use of trisyllabic feet and a less ornate diction to approach nearer to the style of conversation of the educated, and avoid the cadences loved by the vulgar. Aristotle approves of this in the third book of his *Rhetoric*, and says that the uneducated only prefer the more highly coloured poetical language. No less remarkable is the contrast between the unbroken flow of Shakespeare's earlier versification in which the sense generally terminates with the verse, and the broken style of his latest versification in which the line perpetually ends on a weak monosyllable, such as *and, if*, etc. Thus in the *Tempest* we have verses like the following:

Had I been any god of power, I would
Have sunk the sea within the earth, or e'er
It should the good ship so have swallowed, and
The fraughting souls within her.
Thy father was the Duke of Milan, and
A prince of power.
Thy mother was a piece of virtue, and
She said, thou wast my daughter, and thy father
Was Duke of Milan.

Euripides, Seneca, Shakespeare, all alike sought in different ways, suitably to the genius of their different languages, to avoid the monotony of movement, dear to the vulgar, not unwelcome perhaps to the educated ear.

We may derive similar lessons from the history of the Latin hexameter. In it, as I have said, the caesura in the middle of the verse is the central force which binds its two halves into one organical whole; without which it would be no verse at all. Now as the ictus metricus or arsis of the dactyl is on the first syllable, while in the iambic it is on the last, we have the opposite result in the hexameter to what we found to be the case in the iambic. In the iambic ictus and accent are generally in agreement in the

neighbourhood of the caesura; in the hexameter they are for the most part in opposition.

Arma virumque cano Trojae qui primus ab oris
Italiæ fato profugus Laviniaque venit.

These two verses are on the whole very different in their movement; yet in the middle of both alike ictus and accent are in opposition, owing to the nature of the Latin accent. This opposition was of course quite as unintentional, as the general coincidence in the case of the iambic. Both kinds of verse were adaptations from Greek models, and there any intentional agreement must from the nature of the case have been out of the question. *Μῆνιν ἄειδε θεὰ* has precisely the same rhythmical movement as *arma virumque cano*; and there accent and ictus coincide at the caesura. Nay it has been shewn above that words like *illuc, illinc, tanton, talin* are always accentuated on the last syllable. Now in Virgil and other poets we frequently find verses thus commencing: *Expediat? tanton placuit, Arte morer? talin possum, Nunc huc nunc illuc, Nunc hinc nunc illinc*; and these verses have the same rhythmical effect as *Italiæ fato*, etc.; and yet have accent and ictus in agreement, not opposition, at the caesura.

There is another peculiarity to be noted in the structure of the hexameter. Even in Homer, although he has many other varieties, the most common cadences at the end of a verse are either such as *ἄλγε' ἔθηκε, τεύχε κύνεσσιν, ξυνέθηκε μάχεσθαι*, or else *έτελείετο βουλή, ἦνδανε θυμῷ*. In the Latin hexameter, at least in the poems of its great master Virgil and his successors, cadences similar to those just quoted are almost universal, *qui primus ab oris, Laviniaque venit, conderet urbem*. Now in Greek such cadences are of course totally independent of accent. *ἄλγε' ἔθηκεν, Φοῖβος Ἀπόλλων, αὐτὰρ Ὀδυσσεύς, Πάλλας Ἀθήνη, δῖος Ἀχιλλεύς* have all different accents, sometimes agreeing with, sometimes opposed to the metrical ictus; and yet we feel and see and know that the rhythmical movement is in all the same. The case is very different in Latin. From the nature of its accent ictus and accent must generally, not by any means always, be in agreement, when the verse terminates in the manner mentioned. But this coincidence was of course merely accidental, for the accent did not determine the choice of such cadences, but merely a judicious imitation of Greek models. Indeed Virgil excludes carefully such terminations to a verse as *vīs animāi, saecula animantum*, common in Lucretius and others, where accent is just as much in agreement with ictus, as in *primus ab oris, moenia Romae*. Rhythm, not accent, determined his practice. All the great masters then of the elevated heroic have with fine tact, the reasons for which we can feel, if we cannot explain, given to the end this free open fall in opposition to the involution of rhythm which the caesura occasions in the middle of the verse; avoiding unless for special effects such terminations as *ilicibus sus, procumbit humi bos, per inceptos hymenaeos*. And here we come to a phenomenon similar to what we have already encountered more than once. In the oldest specimen of what may be called popular hexameters extant, the Praenestinae sortes, some of which we quoted above, this regular fall of the end of the verse had not yet so fully established itself, and out of the small number of verses, the exceptions to this cadence are very large: *quod rogas non est*, where *quod* and *non* have probably no accent, but join on to the following words; *tempus abit jam; vehi non potes istoc*. We find also *id sequi*

satiust, fit nisi caveas : where there is a resolution of the arsis in the first syllable of the last foot. *Ceciderunt* occurs as a molossus in the middle of another verse. In the Titulus Mummianus, another very old specimen of hexameters, three out of six verses have not the usual cadence of later times; and we meet with one resolution of the arsis *facilia* for the dactyl of the fifth foot.

In Virgil, to take the most perfect master, the caesura of the verse occasions generally a contradiction, the conclusion an agreement between accent and ictus. The other feet of equally harmonious verses may have them either altogether agreeing or altogether disagreeing.

'Arma virúmque cáno Trójae qui primus ab óris
'Italiam fáto prófugus Lavináque vènit.

In the first of these verses we have this agreement in four out of six feet; and had he written *qui Trójae*, as Lucretius or Catullus would probably have done, there would have been this coincidence in five out of six places. In the second verse we find a disagreement five out of six times. Yet the two verses are equally good. Nay we find in the best Latin poets many lines where accent and ictus agree throughout, as in the following from Virgil :

Pállida, díis invísa supérque immáne baráthrum.
Non potuisse tuaque animam hanc effundere dextra.
Hunc congressus et hunc, illum eminus, eminus ambo.
Esto nunc sol testis et haec mihi terra vocanti.
Dô quod vis et mê victúsque volensque remitto.

In Catullus we meet with

Omnia sunt deserta, ostentant omnia letum.

In Lucretius are hundreds of verses like the following :

Quanam sit ratione atque alte terminus haerens.
Impia te rationis inire elementa viamque.
Crescit barba pilique per omnia membra per artus.

Then with regard to disagreements between accent and ictus, we have just seen that the second verse of the *Æneid*, a very excellent one, exhibits five such. So does the thirteenth verse :

Carthágo Itáliam contra Tiberináque longe Litora.

And had he chosen to write

Carthágo Itáliam lónge Tiberináque contra Litora,

since the preposition before its noun has no accent, or, if it has one, has it on the last syllable, there would not have been a single agreement in the whole verse between accent and ictus. Or take this other verse,

Aurúnci misère pátres Sidicináque juxta Aéquora.

Here we have no coincidence in the whole verse, as *juxta* is unaccentuated, except in the third foot where there is at once agreement and opposition. Again in the following verse of Lucretius,

Ille leonis obsesset et horrens Arcadius sus,

we have agreement throughout the first four places; disagreement in both the last. It may be said that *Arcadius sus* is an unusual cadence; so it is, but certainly not on account of the accents. Such cadences are comparatively unfrequent in Homer also. They are avoided by Virgil, except when he wishes to produce some particular effect. But as we have already said, he eschews still more for reasons already hinted at such terminations of a verse as *vis animai, saecla animantum*, which are very common in Homer; and where accent and ictus coincide in Latin. He makes a striking exception to this rule in the case of Greek words, in grateful recognition probably of Homer's movement: and delights in such cadences as *luctu miscere hymenaeos, molli fultus hyacintho, neque Aoniae Aganippe*. Once or twice indeed, in acknowledgement of his obligations to Lucretius, he ends a verse with a cadence like this, *magnam cui mentem animumque*. But as a general rule rhythms like these are much more carefully avoided by Virgil, than others in which accent and ictus are opposed. The *natura tua vi, fortis equi vis, et horrens Arcadius sus* of Lucretius may easily be paralleled by the other's *legitque virum vir, et odora canum vis, sub ilicibus sus*, and the like. His motives for so doing can hardly be doubtful: accent had nothing to do with the matter in either case. He avoided the former kind of movement as weak and unimpressive, except in the case of Greek words; the latter he often purposely sought in order to produce some peculiar effect. It was clearly too for the sake of the rhythmical movement, not the unusual accents, that he so often indulges in hypermetral cadences, like *robora totásque, ipsique nepotésque*, and the like; and that we sometimes find in him such verses as

Quam pius Aeneas et quam mágni Phrýges et quám.

If he really ended two lines in the Georgics with *arbutus hórrida* and *viváque sulpura*, the last foot with its accent on the first syllable is much more harsh than in the other kind of hypermetral lines. Take this other verse of Lucretius,

Próxima fért humánum in péctus templáque méntis.

Here again we have agreement in the first four places, and disagreement in the fifth; and had Lucretius seen fit to write, as surely he might have done, so far as rhythm is concerned, *templáque circum Mentis*; there would have been agreement neither in the fifth nor sixth foot. Indeed there are hundreds of excellent and regularly constructed verses in Virgil and the other poets where we have this contradiction between accent and ictus either in both the last places or in one or other of them. I will not needlessly cite many instances, but what can be finer than the following verses from the first Georgic, perhaps the most consummate model of rhythm in the whole of Latin poetry?

Spicea jam campis cum messis inhorruit, et cúm
Frumenta in viridi stipula lactentia turgent.
At Boreae de parte trucis cum fulminat, et cúm
Eurique Zephyrique tonat domus.

In these two examples ictus and accent are in violent contradiction in the sixth, perhaps the most important part of the verse. Then again there are many scores of lines in Virgil, the fifth foot of which is formed in some such way as this *Lavináque*, where the

accent is in equally violent opposition to the ictus. Let us take this one other illustration. We know from abundant testimony that *déinde*, *périnde*, *próinde*, *éxinde* were accentuated in the manner indicated. Servius among others notices this fact in his comment on Aeneid vi, 743,

Quisque suos patimur manes; éxinde per ámplum.

The accents of *éxinde per ámplum* exactly correspond to those of *múlti comitántum*; and yet how different the rhythmical effect of these two endings. Lucretius again terminates a verse, vi, 1017, with *unde vacefít*. Now we have the most conclusive evidence that *vacefít*, and all cognate words, *tepefít* etc., were accentuated on the last syllable. Yet I believe that to Lucretius the movement of these words was the same as Virgil's *unde Latinum*: to Servius or Priscian it was doubtless otherwise.

As the caesura is of vital importance in the hexameter, and the metrical beat of the dactylic rhythm is on the first syllable of the foot, and the Latin accent is such as we have described it, it is perfectly true that in general those verses will be smoothest and easiest in their movement, in the first three or four feet of which ictus and accent are opposed; the most impetuous and violent those in which there is the greatest amount of agreement in the first four or all the six places. In the iambic and trochaic for cognate reasons we found the contrary to be the fact; the metrical beat of the iambus falling on the second syllable, and the caesura of the senarius occurring, as in the hexameter, in the middle of a foot; the metrical beat of the trochee falling on the first syllable, and the caesura of the trochaic tetrameter always coming at the end of a foot. That the rhythmical movement however, and not the accent, is the occasion of this, may be shewn from many considerations, and also by this fact which should never be forgotten, that the Latin hexameter is entirely borrowed from Homer and Homer's Greek imitators, and any notion of accent having the least influence on his rhythm is belied by every line in the Iliad and Odyssey. Many verses of Lucretius in which accent and ictus have exactly the same relation to one another which they have in many most easy-flowing verses, are more violent and unusual in their rhythmical effect than any of the verses quoted above in which ictus and accent coincide throughout. Out of hundreds of examples take these:

Et membratim vitalem deperdere sensum.
Quidve tripectora tergemini vis Geryonai.
Quidve superbia spurcicia ac petulantia? quantas.

Take again the following;

Séd bóna magnáque párs servabat foedera caste.

Here the accents are arranged exactly as in a verse of this kind:

Séd véterum bóna párs servabat etc.

Yet how different is the metrical effect of the two. The following line of Virgil is quite unexceptionable:

Thesaúros ignôtum argénti pondus et auri.

Substitute *férri* for *argénti*. The accents remain identically the same; yet instead of a

verse you get an inert unrhythmical mass. Again owing to certain exceptions to the general rules of Latin accentuation we find verses in which accent and ictus coincide throughout, and yet the rhythmical movement is smooth and easy, as in this of Virgil :

Sanguine adhuc campique ingentes ossibus alent,

and the following from Lucretius :

Nec potuisset adhuc perducere saecula propago.
Nunc huc nunc illuc in cunctas undique partis.
Nunc hinc nunc illinc abrupti nubibus ignes.

Others too without such exceptional accents are simple enough in their rhythmical movement; as these of Virgil,

Funera nec cum se sub leges pacis iniquae.
Omnia jam vulgata. Quis aut Eurysthea durum,

and this of Tibullus (Lygdamus),

Non ego firmus in hoc, non haec patientia nostra,

and these two consecutive verses of Lucretius,

Tam manet haec et tam nativo corpore constant,
Quam genus omne quod hic generatim rebus abundat.

What shall we say of the following excellent verse of Virgil,

Quid loquor? aut ubi sum? quae mentem insania mutat?

in which accent and ictus agree throughout, and at the same time also disagree in the first three places? Of this from Lucretius,

Cum metus aut dolor est et cum jam gaudia gliscunt,

in which accent and ictus agree throughout, and at the same time disagree in the first, second and fourth places; and the third foot is made up of the enclitic *est* and the atonic or proclitic *et*? In this case however I will not vouch for the fact that *cum*, *aut*, *cum*, *jam* had all distinct accents: I believe they had to Lucretius and Cicero, not to Servius and Priscian. The whole history of the language proves that atonics went on increasing in number, until they had reached quite an inordinate amount at the time when Latin was passing into its Romance daughters. This would seem to be the main cause of the total disappearance of so many of the most serviceable Latin particles from these dialects. This simultaneous coincidence and contradiction between the two would seem indeed to be a strong ground for assuming that the former has no direct influence whatever on the rhythm. Movements like *Quantus Athos aut quantus Eryx*, *Arma viri ferte arma vocat* must of course occur perpetually.

Sometimes indeed the poet will by peculiarity of rhythm designedly produce a peculiar effect, and accent and ictus will agree in all places as in these verses of Virgil :

Saucius ora ruitque implorans nomine Turnum.
Impius haec tam culta novalia miles habebit.

But this agreement is surely accidental.

Take again this line of Lucretius,

Práva cubántia próna supína atque ábsona tétta.

Here unquestionably sound is meant to echo sense: and the rhythm appears to be modelled on Homer's

πολλὰ δ' ἄναντα κάταντα páραντά τε δόχμιά τ' ἦλθον,

where in the first four feet oddly enough accent and ictus are in flagrant contradiction. Again if the verse of Lucretius be read in the following manner: although I do not mean to say that he intended it to be so read:

Prava—cubantia prona—supina atque absona,

the rhythm is by no means unpleasing, not nearly so much so as that of many verses where the coincidence in question does not exist. Or substitute this verse,

Procumbéntia semisupína atque absona tecta.

In this case the rhythmical movement is much more disagreeable, yet coincidence is less complete between ictus and accent. Again the many Latin words which have no accent, and the necessarily frequent occurrence of whole feet formed out of the unaccentuated parts of accented words would afford a strong argument that accent has no direct influence upon rhythm; for Cicero and other ancients lay it down as contrary to the very nature of things for one word to have more than one accent.

Rhythm we have now seen was in Latin as in Greek quite independent of accent which had no direct influence on it whatsoever. But as quantity on which it rested was divided into various portions by caesura, pause and due arrangement of words, it well might be that in consequence of the limited range of the Latin accent it might gradually obtain a certain indirect influence over some parts of the hexameter, as of the iambic or trochaic: habit being all-powerful in this as in more important matters. I wish therefore now to shew that there was this tendency, a feeling in favour of an association of accent and ictus, and in particular cases a studied endeavour to avoid such. Lucretius obeys of course the genius of the hexameter in his management of the caesura. But his favourite movement at the end of the verse is to have not only the two, but the three last feet arranged in such a manner as to produce in general a coincidence between accent and ictus. Take the first forty-three verses of his poem, a highly elaborated passage, and you will find more than half the number to have cadences like these, *quae terras frugiferentis*, not *terras quae*; *exortum lumina solis, tibi suavis daedala tellus*, not *suavis tibi*; *tibi rident aequora ponti, diffuso lumine caelum, genitabilis aura favoni*, and so on. This produces a grand and stately, but somewhat monotonous effect. Catullus carries this peculiarity even farther than Lucretius, and with his usual grace; but the result is the same. Virgil and his followers, and before him the author of the *Dirae* whose two short poems are chiefly noticeable, because they seem to have been to some extent taken by Virgil as a model, manifestly wish to avoid as a rule this cloying monotony. Virgil says *Trojae qui primus*, not *qui Trojae*; *labentem caelo quae ducitis annum*, not *quae caelo labentem*. Not but that he employs this cadence, and frequently too, to produce a solemn and majestic effect. We have not to read far in the *Æneid* to find *Albanique patres atque altae moenia Romae, Tanta molis erat Romanam condere gentem, Illum expirantem transfixo pector*

flammas. But he felt with his unerring tact that the inordinate employment of this cadence necessarily occasioned monotony; and he gained ease and variety with the sacrifice perhaps of some grandeur. In a speech of Jupiter to Mercury in the fourth Aeneid there are many consecutive lines twice repeated with this movement; but the result is to my ear unsatisfactory, stiff not stately.

I will now refer to a studied pursuit of such a rhythmical movement as produced a general contradiction between accent and ictus, a stronger proof perhaps of the increasing power of the former, than a studied agreement. Horace, wishing in his satires to produce verses *Sermoni propiora*, nearer to the style of ordinary conversation among the polite and educated, and hating the 'profanum vulgus', must have clearly felt, as Seneca did, that the rhythm which produced that almost unvarying coincidence between ictus and accent now prevailing in the last two places of the hexameter, occasioned, where the verse was not very elevated, a vulgar monotony pleasing to the common ear, like the chants of Caesar's soldiers. While therefore in the first four feet he allows his rhythm to proceed much in the same way as that of other poets, he has in the last two places, one or both, made accent and ictus to disagree in a proportion extraordinarily great, if he be compared with his contemporaries or successors, even those in his own line, Persius and Juvenal. The first two satires will give I believe more than forty illustrations of what I mean; and the result thereby produced is certainly very striking and, as he meant it to be, unpoetical.

If time allowed, I might illustrate my views of the increasing influence of the accent by various peculiarities in his odes also. I will mention but one which I have carefully noted. In his earlier alcaic odes he not unfrequently has an iambus for the first foot in any of the first three lines of the stanza. The first book contains, if I have counted right, thirteen instances of an iambus so placed. Of these thirteen instances, six have the cadence *vides ut alta, frui paratus*, where the accent is on the short syllable of *vides, frui*, etc. In the second book out of eight cases only one *cóhors gigantum* has this cadence. In the third, out of seven instances not one has that cadence. In the fourth, in which he generally observes more stringent rules, there is no instance of an iambus whatever. This can hardly be accidental. As Horace disliked generally the short syllable at the beginning, the accent must have brought it out in stronger relief, and have induced him to avoid the conflict between it and the short syllable. In his sapphics the poet, in striking contrast to his mistress Sappho, never has a trochee for the second foot. Catullus however in his two short sapphic odes, which seem to some extent to have been followed by Horace as his model, has three instances of a trochee in that place. In all the short syllable is unaccentuated *Seu Sacas sagittiferosque Parthos, Pauca nuntiate meae puellae, Otium, Catulle, tibi molestum est*; and yet in the sapphics of Catullus as of Horace the fourth syllable of the verse is commonly accentuated. Of course to Sappho a short syllable in this place was just as acceptable as a long, under any conditions whatever. But the magnificent freedom with which she wielded this noble measure, was quite unattainable by Horace, or even by Catullus. Similarly the first and fifth syllables of the first three lines of the alcaic stanza of Alcaeus were indifferently short or long.

I have thus endeavoured to shew that already in the Augustan age accent exercised a certain

though quite subordinate and indirect influence on Latin versification. Quantity was as yet altogether intact, and in full possession of all its rights; and the accent was as yet no stress, but a mere heightening of the intonation. Quantity was still in full force in the early half of the second century, as we know from the poets of that period and such critics as A. Gellius. After that time there is a great break in the extant Latin literature; and during the century that followed the language must have grievously degenerated. In the third century quantity was far other than it had been. When the boys of Rome salute Aurelian in his triumph, their verse is no more like that of Caesar's veterans.

Unus hómo mille mille mille decollavimus,
Tantum vini hábet nemo quantum fudit sanguinis,

are virtual accentual verses. In better times the accent had no power to prevent the accentuated *i* of *fierem* and *feri*, which once had been long and in the time of Plautus was yet common, from becoming necessarily short in the time of Virgil; while the unaccentuated *i* in *fiébam* and *febámus* was still long. But now the accent has become a stress, and can render a short syllable long. The passage has been made from the ancient to the new. Of course for some centuries after in learned schools the knowledge of the old quantity was kept up by artificial means. But we can see from the greatest grammarians, Servius, Priscian, etc., that it was acquired, as we acquire it; was no longer a living reality; and that a writer when left to his own resources wrote like Praecilius or Commodian. We see too that, with the exception of Claudian and one or two other happy imitators, the artificial verse was less poetical, less vivid than the accentual popular songs and Church hymns, which by degrees more and more confirmed themselves in a total rejection of quantity and a full acceptance of the power of the accent, now become purely a stress like our own or the Italian. Rhyme was soon added; until we come at length to the *Dies irae*, *Stabat mater* and to the poems of Mapes, many of them beautiful enough in their simplicity. These are really the same rhythms, as the song of the Roman boys in Aurelian's time. A large part of their impressiveness is owing to the trochaic rhythm which suits admirably the accentual unquantitative Latin. The other accentual imitations of old metres, such as the many written in mimicry of the Asclepiad *Maecenas atavis*, are for the most part far less successful; as the writers were unable to distinguish between this and a dactylic rhythm.

To make the subject at all complete, it ought to be shewn as could easily be done, that about the same time or soon after the same strange change came over the Greek language. It likewise completely lost its quantity. A very few words on this head must suffice.

Why it was that in the third century such a complete revolution occurred in the speech and the whole life of the old classical peoples, I cannot tell. Ancient things then seemed to be passing away. Almost continual wars, pestilences and famines oppressed the human race; and when at the end of that century some vigorous rulers appeared for a while to uphold and restore the perishing empire, the new order of things was far other than the old. The modern world had already begun.

It seems to be with languages as with other things: when they cease to grow, they begin to decay; and after the period of the Attic orators the Greek underwent a rapid

degradation. After that time poetry, and prose when it has the least merit, are merely imitative. Yet for centuries the prosody of the language continued safe. The first symptom of decay, and a very noticeable one it is, with which I am acquainted, is afforded by the choliambics or scazons of Babrius who appears to have flourished not later than the beginning of the third century: Bentley calls him the last of the good writers. The most marked feature of that verse is the concluding spondee. Now Babrius is not content, as Hipponax and all the older writers of it were, with the simple quantity; but the first syllable of every concluding spondee has an accent acute or circumflex. That this could be accident is of course out of the question in several thousand lines. There are a good many corrupt verses, and when Lachmann published his edition, he, strange to say for a man so singularly observant of such points, did not perceive this peculiarity; and among the verses emended by him and some others of the leading scholars of Germany, a large proportion, as might be expected, neglect this law: which makes its constant observance by Babrius the more striking. To Hipponax this would have had no meaning. The fact that this concluding spondee could not trust to quantity alone, but required the support of the accent, shews that the latter had then begun to be a stress; and that the noblest language for form and structure which the world has ever seen, was already stricken with a mortal malady. After this period decay advanced with rapid strides; Greek or rather Hellenic soon ceased to be a spoken, a living tongue; certainly as soon as the seventh century, probably long before, the distinction between long and short syllables had been entirely lost. Yet the effete Constantinopolitans still clung with tenacious pedantry to the galvanised corpse of the old Greek, and would not allow the Romaic to develop itself freely, as the Romance tongues were doing. As for verse, they had recourse to some of the basest expedients that have ever perhaps been devised. For a long time they measured verse by the eye; said η , ω , and the diphthongs shall be long, because the ancients said they were; ϵ , $ο$ shall be short, and the other vowels long or short at discretion. Finally after struggling for centuries against it, they were obliged to let accent have its rights and exercise the power it had acquired in their spurious Hellenic as well as in the living Romaic. They adopted universally the old comic tetrameter catalectic, written of course accentually, the accent making every alternate syllable long as well as its own syllable, and all monosyllables being indifferent.

Ὅς ἦδομαι καὶ τέρπομαι καὶ βούλομαι χορεύσαι

is a good model, as it so chances that the accents of this line correspond to the quantity. Had this not been so they would have had no idea of its rhythm. Thus if the accents of a tragic tetrameter catalectic suited, it might be turned into a good accentual iambic tetrameter, as for instance

Ἦ βαθυζώνων ἄνασσα Περσίδων ὑπερτάτη,

thereby completely reversing the movement of the metre. Nay the majesty of Homer was not safe, if these conditions were fulfilled by any of his verses: if they had fifteen syllables, if there was a break after the eighth syllable, and if with all this the accents suited. We need not look far in the Iliad to find the following:

*ἀλλ' ἔνεκ' ἀρητῆρος ὃν ἠτίμησ' Ἀγαμέμνων.
ἦ κεν γηθήσαι Πρίαμος Πριάμοιό τε παῖδες.*

The golden harp of Apollo transmuted into a vile droning hurdy-gurdy! A modern Greek gives to these verses the identical rhythm of

A captain bold of Halifax who lived in country quarters:

as well as to this Ithyphallic,

Οὐ βέβηλος, ᾧ τελεταὶ τοῦ νέου Διονύσου.

The writer of a well-meant book on Greek pronunciation, a member of this university, finding this quoted by Dionysius, has committed the enormous blunder of supposing that Dionysius is talking of accentual verse which to him was a nonentity; and of asserting that the people of old Greece employed them, because they were unable to appreciate quantity. When that verse was written, the meanest peasant had as perfect a knowledge of quantity as Plato. But the Hellenes and Philhellenes of to-day tell us in vain that they speak and write the language of Xenophon. You might as well take the language of Dante and Ariosto, had Dante and Ariosto never lived; mix it up with the Latin of the schoolmen and canonists of the middle ages, add some half-understood purple patches from Cicero and Virgil, and say, Here you have the language of Caesar, Cicero and Virgil. ἦ κεν γηθήσαι Πρίαμος! In spite of all passionate protestations to the contrary, Italian has retained far more of the old Latin than genuine Romaic has of the old Greek; and for this reason among others that Greek is a much more copious language than Latin, Romaic a much poorer one than Italian. The latter has preserved much more of the old vocabulary and the old pronunciation; has even changed in much fewer cases the place of the old accent: the point on which the modern Hellenes most boast of their close adherence to antiquity. In sober truth the debased Latin accent may be said to have created the Italian and the other Romanic tongues. *Siede la terra dove nata fui* represents exactly the pronunciation and accentuation of *Sedet illa terra de-ubi nata fui* in the sixth or seventh century. The Hellenic of Tzetzes, Tricoupi or the Vretannikós Astír is as much a dead language as the Latin of Dante or Petrarch, Bentley or Lachmann.

After this lengthened introduction I will now make a more minute dissection of our epitaph. It is, as I have said, decidedly a purer and a better specimen of accentual verse than the corrupt poems of Comodian; and far more complete than the many later inscriptions to be found on tombs and other monuments, where the writers seldom break so entirely with quantity as Praecilius does.

The key to the right understanding of these and similar verses is to remember that Praecilius in studying his Virgil read him by accent and not by quantity, for which he had no natural feeling whatever, and which neither his nurse nor his schoolmaster had ever taught him artificially. What struck him in every line of Virgil was first the caesura, the keystone of the whole; or rather that which he took to be the caesura; a point on which he often differed from Virgil; and secondly, owing to the peculiar nature of the Latin accent and the usual cadence of the Virgilian hexameter the dactylic fall of the end of the verse whether read accentually or according to quantity. Of the portion preceding the caesura he had a far less distinct conception. *'Arma virúmque* had to him the

regular dactylic cadence, because accent and quantity are here in agreement; *Itáliam fáto* was quite another thing. *Cáno, Trójae, prímus, quóque* had all the same quantity to him; and therefore the same force in verse; just as they would have to an Englishman knowing the language but ignorant of its prosody: so that it quite depended on the general structure of the verse whether they should be long or short. The same is to be said of *prófugus, lítora, súperum, cónderet* etc. Again *Itáliam fáto* had to him precisely the same rhythm as his own *Sequímini táles*, or *Praefátio nóstra* with which Commodian opens one of his poems. Virgil could commence a verse with *Arcébat lónge*; why should he not do the same with *Cirténsi lárē*? Where they came conveniently to hand, he seems to have preferred dactylic openings, speaking of course accentually; but finding as many of Virgil's lines without this movement as with it, he did not trouble himself to avoid a different rhythm when it suggested itself to him.

Another leading peculiarity of his versification should be noticed: he did not acknowledge the synaloepha, and in reading Virgil never elided a vowel. Of course Virgil did not altogether suppress the elided vowel; that would have ruined his harmony; he allowed the one to run into the other and produce a composite sound. This absence of elision is characteristic of all the later accentual poems, church hymns and such like, in striking contrast by the way to the frequency with which it is employed in Italian poetry. Praecilius accordingly must have recited many of Virgil's verses with a singular kind of trochaic jumping cadence which has had a powerful influence on the structure of his own poetry. He must have read *Litora multum illē et terris jactatus et alto, Trojanō ā sanguine duci, Spretaequē injuria formae, Teucrorū āvertere regem*, etc. He had no feeling for such lines as *Aggeribus socer Alpinis atque arce Monoeci Descendens gener adversis instructus Eois*, read as Virgil read them. He preferred *Descendens gēnēr adversis instructus Eois*, which sounded as gratefully to his ear as his own *Cirtensi lārē, ārgēntariam exībui artem*. And similar conceptions, I presume, of the harmony of Virgil and Homer will be entertained by the youth of England, when the advancing intelligence of the age shall have completely sacrificed the ornamental to the useful and proscribed at Eton and Cambridge the practice of writing Greek and Latin verses.

Praecilius could have known no distinction between the circumflex and the acute; both must have been to him one and the same stress. For obvious reasons however I have printed his words with the accents which Cicero and Virgil would have employed; and, in order to prevent confusion, I have not for instance given to *invēni* the circumflex which of course it would have had, if the final *i* had become short in classical times.

I have already given the epitaph as copied by Mr Blakesley, subjoining first his version and then my own arrangement of it into verses, in which the faults of orthography committed by the stonecutter are corrected; but those are left which I conceive to be due to Praecilius himself, as being characteristic of the Latin pronunciation of his time. It will be seen for the reasons already so often alluded to that the harmony of the verses such as it is depends mainly on the caesura in the middle and the accentual dactylic cadence at the conclusion of the verse.

1. *Taceo*, if not a mistake for the usual *jaceo*, is a play on it to contrast with *versibus*

silent myself, I speak in my verses. If *mea vita* is right, it proves, as does *clara* in v. 2, *luxuria* in v. 6, and *sanctam* for *sancta* in v. 8, that the final *m*, as Mr Blakesley observes, was now mute: and this is confirmed by thousands of late inscriptions. In the best classical times it had, as is well known, a dull half-suppressed sound which was often represented in writing by a half letter. In the oldest inscriptions it is frequently omitted, before the date when the poet Attius, a great grammatical reformer, fixed its place in the orthography of the language; thus rendering at least one essential service to the grammar of his language, on the declensions and conjugations of which the loss of the final *m* would have had the most disastrous consequences, as is well proved by the transition of Latin into the Romance tongues. The early loss of this final letter contributed much to the rapid decay of the Umbrian, as we know from many existing monuments. In *demonstro* the *n* was almost or quite mute, but the *o* was proportionately lengthened. We know on the authority of Cicero and others that this was generally the case when *n* preceded *s* or *f*. Hence *thensaurus* is the genuine Latin form of the Greek *Θησαυρός*. The unaccentuated *de* was thereby rendered probably shorter than it would otherwise have been to Praecilius. Commodian opens his *Instructiones* with this line *Praefatio nostra viam erranti demonstrat*. The later poets, even those who profess to observe quantity, perpetually shorten this *de* in composition. Even so good a grammarian as Servius, who lived of course when quantity had to be acquired by artificial rules, tells us that in a word like *amicus* you know by its accent the second syllable to be long, but must learn the quantity of the first *arte*, that is by your *gradus*. Now as Praecilius had no *gradus*, he took the liberty of making the first syllable of *demonstro* short at the conclusion of his verse, and the first syllable of *honeste* long in the first part of verse 9. He knew no difference in quantity between *demonstro* and *recondo*, *honeste* and *venisse*, the accent in all cases determining only the length of the penultimate. In the same way *vérsibus* sounded to him the same as *prófugus*, *titulos* in v. 11 the same as *litora*. His first line had for him precisely the same cadence as *Hic ego qui taceo, numeris mea fata recondo* would have had.

In v. 2 the last two syllables of *Praecilius* coalescing probably rendered the accentuated *i* peculiarly long, and the *prae* proportionately short, though even to writers who profess quantity in the fourth and following centuries this *prae* was essentially a short syllable. Even so early as the first century *ae* came to be used to denote the short open *e* in words like *praemo* etc.

V. 3 was no less rhythmical to Praecilius than *Emollit mores didicisse fideliter artes*. The first syllable of *lare* with its clear liquid sound was perhaps more distinctly long to him as to a modern Italian, than the *a* in *arma* or *fato*. Compare the Italian pronunciation of *mare*, *mano*, *rosa* etc.; and *fydes* in v. 4 and the Italian *fedé*. In the ac-centual church hymns, attributed to St Ambrose by Bede and others, quantity is observed with more or less care; yet we find such a verse as *Qui éras ante saecula*. The *e* of *eras* was as long as the *a* in *lare*. The frequency with which Commodian uses words like *duce*, *quoque*, *neque*, *homo* and such like for spondees or trochees is very striking.

The last syllable was of course quite as indifferent to him and Praecilius as to a modern

Italian. In an old inscription in Gruter occurs this line *Hunc quōquē tristes veniunt et laeti recedunt*. *Pāter* became quite as long as *māter*, *frāter*. Compare the Italian *padre*, *madre*, *frate*, and the French *père*, *mère*, *frère*. The *o* in *pópolis* from *pōpulus* is perhaps longer than in *pióppo* from *pōpulus*. The strongly accentuated *a* in *argentárium* made the first two and the last syllables so much the shorter; the same may be said of the *i* in *exibui*. Even professed Grammarians like Priscian and his contemporaries, when they are expounding the rhythms of prose sentences, often pronounce the accentuated *i* of words like *exhibui*, *hospítibus*, *perspícere* to be long. The same may be said of the *u* in *luxuria* of v. 6.

In v. 5 the unaccentuated *non* was naturally short to Praecilius especially after the caesura, when the movement of the verse suggested it, just as in the *noninveni* of verse 7.

The movement of v. 6 was to Praecilius identical with *Arma virumque cano placida composita quiete*. The sound of *n* or *m* before *c* in *cuncaris* was we know something between an *n* and *g*. So was that of *n* in *anquiro* or *angelus*; of γ in $\acute{\alpha}\gamma\gamma\epsilon\lambda\omicron\varsigma$.

Again the first clause of v. 7 has the rhythm of *Arma virumque cano*, Praecilius' favourite trochaic canter. The unaccentuated *post*, like other prepositions, was closely connected with the noun it governed and formed indeed one word with it. Compare the *postempus*, *pomeridianus*, etc. of the old writers, of Cicero and Virgil. *Obitus* was pronounced *obtus*; *domnus*, *domna* were early corruptions. Compare *dompna*, *donna*, *dame*. The editor of the new poem of Commodian calls himself on the title page *Domnus Pitra*. In all periods of the language this tendency to contraction was very strong. With *obtus* compare *doctus*, *raptus* etc.; with *domnae lamna* for *lamma*, *autumnus*, *vertumnus* and fifty similar words. The quantity of *Valériae* in this verse appears at first sight the most difficult point to explain in the whole epitaph. The last two syllables are of course contracted into one as in *argentariam*, *luxuriam*. The accent therefore of *Valériae* is especially emphatic. I offer the following explanation. Gellius tells us that it was an exceptional peculiarity of the Latin language to accentuate the short penultimate of the genitive and vocative in words like *Valerius*, *Vergilius*, and to pronounce *Valéri*, *Vergíli*. The singular pertinacity with which Servius and other grammarians point out this fact, proves it to have been something very unusual. Thus Praecilius would have read in Horace *Contra Laevinum Valéri genus, unde Superbus*; and this and similar verses might well have been impressed on the rich banker's mind, if his wife Valeria was used to recount the ancient glories of her name. The whole verse therefore had to him the same flow as *Arma virumque cano Valéri nec amare pudice*. Of *non inveni* I have already spoken.

In v. 8 *habui* is a dissyllable like the Italian *ebbi*, and the whole verse had the cadence *Vitam cum potui memor ire per omnia saecula*.

In v. 9 the metrical value given to the first syllable of *honeste* and of *felices* is solely due to their position in the verse. Even before quantity was totally lost, there was a strong tendency to shorten the final *e* in adverbs, as had been done from the earliest times for *bene* and *male*. But Praecilius would have given himself little concern about such matters. To him almost every final syllable was as essentially short, that is to say as unaccentuated, as in modern Italian. *Meos* is a monosyllable, as it so often is in Ennius,

Plautus and Terence. Praecilius too probably linked it on to *centum*. In *celebravi* the first two unaccentuated syllables were slurred over as one. Compare *Ut si perseveraveris*, the beginning of one of Commodian's verses. Many other illustrations might be given. The flow of this verse might be represented by the following fictitious one *Natales venisse per arma sacrare fideles*, the writer's favourite trochaic amble.

V. 10 at first sight would appear to have eight feet; but *venit* is a monosyllable, as we find in the classical *fert, vult*; and in late inscriptions *fect* for *fecit*, *vixt* for *vixit* and such like. Perhaps Praecilius could only thus distinguish the present *vēnit* from the perfect *vēnit*. *Dies* is a monosyllable. This word probably soon became shortened in familiar speech and unable to support an independent existence; and so made way for the *jornus* of middle Latin, and the *giorno, jour* etc. of the Romance languages. Commodian uses *diem* for one short syllable and *medius* for a pyrrhic, and frequently *Zabolus* for *diabolus*. Probably he and Praecilius pronounced *dies ses*. We know from Servius that the *d* of *medius* was universally a sibilant in his day. *Ut* was quite atonic and therefore absorbed in the strongly accentuated *spiritus*, contracted by its accent into a dissyllable. Compare the *spirto* of Italian poetry and the French *esprit*. Their want of accent will perhaps explain the curious fact that so many of the most serviceable Latin particles have like *ut* disappeared from the Romance tongues, and been replaced by the awkward *perche's percioche's dependant's* and the like. The line will therefore have this cadence *Nunc it amica sed altus inania membra relinquat*, the loved dactylico-trochaic run again. Compare with this and the preceding verse such lines of Commodian as the following:

Componitur aliā novitas caeli terraeque perennis.

V. 11 presents no difficulty. *Titulos* might be a dactyl to Praecilius as well as *litora, conderet, moenia*. With *legis* compare *lare*; its position in the line makes it long. *Mee* is for *meae*, as *venitae* on the other hand for *venite*, and the final *ae* is as short as the *i* in *mihī* or the *a* in *mea*. This tendency to abbreviate final syllables was strong in all periods of the language, even the most classical. The ablative *mortē* was once as long as the dative *mortī*, the nominative *musā* as the ablative *musā*.

V. 12, *Deseruit* has naturally the same quantity as *exibui*, and the *me* is probably atonic, and attached to the verb like the *mi, ti, si, me te, se's* of the Romance languages.

In v. 13 *Sequimini tales* sounded to Praecilius exactly like *Itāliam fato, Praeterea supplex*, or the *Praefatio nostra* of Commodian. Its position in the verse determined the quantity of *sequimini*.

The end which I have proposed to myself in this paper, has been to shew by a real visible example the essential difference between the old classical languages with their fully developed quantity moving in harmonious combination with the light musical accents; and their debased and degraded state, when they had forfeited the first and had transformed the second into a stiff monotonous stress; a stress inherited by ourselves, and the other chief European nations, so that it is now difficult for us without much thought to bring the reality fully before our minds and persuade ourselves that the capacity of a language for

that rich variety of beautiful rhythm has passed irrecoverably away. Only a few weeks ago I read a pamphlet by a noble lord, in which he proposes to restore to our language the prosody of the ancients by the help of the two universities who under the sanction of a royal commission shall appoint syndicates composed either of resident or non-resident members, who shall authoritatively determine what syllables shall be short or long or common.

Alas! when the world was younger, the cowherds and milkmaids of Ariana executed that task with a marvellous precision, and constructed glorious forms of language, to be afterwards developed into Indian Vedas and Greek Iliads and Latin Æneids. But that faculty has long been lost; and neither noble lords, nor royal commissions, nor universities, no nor syndicates, resident or non-resident, can now bring back, *Quod fugiens semel hora vexit*. But what this university can do, and long has done, is to encourage and enforce a study of that ancient prosody, without the knowledge of which not only the poetry of Homer, Sophocles and Virgil, but in an almost equal measure the prose of Plato and Demosthenes and Cicero and Livy would be robbed of all its power and beauty.

APPENDIX.

WHEN this paper was prepared in the early part of last year, I was not aware that the inscription had been copied by any one except Mr Blakesley. I afterwards found that it was inserted in the collection of Algerian inscriptions published by the French government; where references are given to various French Journals, none of which I have seen. My paper, as the reader will perceive, was more adapted for oral delivery than for the press; and soon after it had been read, I received the second volume of Corrsen's elaborate work on the *Aussprache Vokalismus und Betonung der Lateinischen Sprache*: in which volume the subject of Latin accentuation is treated at very great length. For these and other reasons I had quite given up the thought of publication, when my attention was lately called to an article in Fraser's Magazine of last month written by a most able and accomplished critic who signs himself J. S. It is headed 'Arnold on translating Homer.' Its main purpose is to prove that the movement of the best English hexameters which the writer has seen is so very unlike the movement of any Greek or Latin hexameters, that the thing is an absurdity and a translation of Homer in such a metre altogether out of the question. With much of his elegant criticism every reader will agree. Some of his principal positions however are so contrary to all that I have attempted to prove above and appear to me to be so wide of the mark, that I have been mainly induced to print my paper in order to make public this difference of opinion.

The evidence to my mind is so overwhelming, I hold it to be an axiom that the old Greeks and Romans had an instinctive feeling for and knowledge of quantity; that upon this instinct depended the whole force and meaning of their rhythmical measured verse; that their accent resembled our accent only in name, in reality was essentially different; that the internal decay of those languages occasioned the ruin of quantity, that consequently the accent, before an intonation, now became a mere stress like the Italian, Romaic, English or German accent; and that if the English hexameter has been or ever is to be successful, that success has been or is to be attained by following out the analogy of other modern metres and making accent replace the ancient rhythmical beat.

The critic in question looks on all this as a mere delusion; maintains that Virgil's accent was the same as our accent; that, though we cannot tell what Homer's accent was to Homer, to us it is the same as Virgil's, that is to say as our own; and that in English quantity is as distinguishable as in Latin or Greek by any ear that will attend to it. Then after defining the English hexameter accurately enough; and also the Virgilian so far as quantity is concerned, he goes on to say with regard to the latter, that quantity is not the only condition of the metre. 'The accent also must be distributed according

to certain laws. Of the six long syllables [forming the six metrical beats] the two last *must* be accented. Of the remaining four, any one, two, or three *may* be accented. All four *must not*. Subject to these conditions, the accent may be placed any where, and the rhythmical effect depends mainly upon the management of it.' He adds in a note: 'The rule with regard to caesura is, I believe, involved in the rule for the accent.' But on this last point he does not explain himself any farther. I have already discussed this question so fully, that I will only here repeat that accent has nothing to do with the Virgilian hexameter. Its rhythm depends entirely on caesura, pause and a due arrangement of words. Accent may agree or disagree with the metrical beat throughout. Surely too the Virgilian is constructed on the model of the Homeric verse, and with it accent could have had nothing to do. But no. 'All that we know of the Greek pronunciation, is that the rule of accentuation was in Quintilian's time different from the Latin. What it was in Homer's time, Quintilian himself probably did not know.' Quintilian knew this rule as well as Homer, and so do I know it; and so does J. S.; otherwise what is the meaning of those marks which he so carefully places over all the Greek words quoted by him? This casual, and, because casual, most important remark of Quintilian I shall presently say more of. Meanwhile let us concede for the moment that by a miraculous anachronism Homer read his verses with the Latin accent. Yet surely it was with Virgil's, not with our or Dante's Latin accent. However 'in Homer we do find now and then a line which reads like an English hexameter—viz. a line in which all the six long syllables are accented, as *αὐτίς ἔπειτα πέδονδε* etc.' 'Such lines are rare even in Homer, as any one may satisfy himself if he will read a few pages of the Iliad.' To this I would reply: 1. Our English reading of Homer and Virgil has in itself no meaning. All the wondrous harmony we feel is derived from the mental process by which we superinduce our acquired knowledge of the quantity and rhythm. 2. Verses like those just mentioned, instead of being rare, are among the very commonest types of Homeric rhythm. There must be in Homer thousands of verses like *Τὸν δ' ἠμείβετ' ἔπειτα ποδάρκης διὸς Ἀχιλλεύς*, or *Ὡς ἔφατ' οὐδ' ἀπίθησε Γεῆρῆμιος ἱππότης Νέστωρ*. I have counted sixteen or seventeen of them between vv. 78 and 178 of the first book of the Iliad. If the same proportion holds throughout, there must be as many as four thousand in the Iliad and Odyssey together. But I confess that to me this obtruding of the Anglo-Latin accent on Homer seems almost an absurdity. And where I would ask is this said Anglo-Latin accent in words like *Πηληϊάδew* or *tempestatúmque*? Does it outrage Cicero's 'Nature of things' and occur more than once in the same word?

Let us now recur to the pregnant passage of Quintilian. What he says is simply this. Even the most learned old people in his youth pronounced all Greek words with the Latin accent, as *'Atreus*. In his time, and ever after as we know from abundant testimony, Greek words, provided they retained their Greek form, retained their Greek accent, as *Atreús, aér, aethér* (? *Atreús*, etc.); *Atréa, aéra*; but *áeris, Achíllés*. Quintilian and his contemporaries gave a pedantic preference to everything Greek, even in points where their own language had the advantage. They naturally therefore liked the more varied and flexible Greek accent. But everything proves that this change in the place of the accent made no real difference to their ears in the metrical movement of the verse. Let us write down these two verses from the fourth Georgic with Virgil's accentuation:

Altáque Pangaéa et Rhési Mavórtia téllus
Atque Gétae atque Hébrus et Actias Orithyía.

Quintilian pronounced *Pángaea*, *Actiás*, *Oríthyia*; and doubtless this accentuation in his opinion gave to the words a certain additional volatile grace. But the rhythmical movement was to him precisely what it had been to Virgil. Virgil again said *Harpyía Celaéno*, *Órpei Calliópezá*, *Charýbdis*, *Eurýsthea*, *Daréta*, *Théseus*, *Caénea*, etc. etc.; Quintilian *Hárpyia Celaenó* (? *Celaenó*), *Orpei Calliópea*, *Chárybdis*, *Eurysthéa*, *Dáreta*, and so on. Nero, or whoever the poet was, who is satirised by Persius, in 'closing his verse' with *Neréa delphín* (? *delphín*) luxuriated no doubt in the Greek intonation with which he trilled forth these words. But in all these cases the rhythm remained unchanged by change of accent. The accent to them, whether Greek or Latin, was only a heightening of the tone with which the syllable where it fell was pronounced. In the time of Priscian and Servius a great change had already taken place. Greek words were still pronounced with the Greek accent; but both the Greek and Latin accent had changed their nature. Quantity had perished; and was only to be acquired by artificial training. What was casually noticed by Quintilian, was to them a matter of vital importance. In his comment on Georgic I, 59 Servius says, 'Sane *Epíros* Graece profertur, unde etiam *e* habet accentum. Nam si Latinum esset, *pi* haberet, quia longa est.' Again and again does he notice this Greek accent. To his ear the accentuated syllable was long, every other short. By study alone he learned the real quantity. We know, he says, the *i* in *amicus* to be long, because it has the accent; the quantity of the *a* we know only *arte*. He therefore pronounced *Epíros*, just as a modern Greek does *ἠπίρος*; he knew only by his *art* that the *i* was long. On the other hand he said *Ēpírus*; he knew by his art alone that *e* was long. So also he pronounced *Pángæa*, *Actiás*, *Órithyía*, *Chárybdis*, and the like. To the ear of Virgil or Quintilian *altáque* was as perfect a dactyl as *árdua*; *évinde* had the same quantity as *exíre*. To the ear of Priscian or Servius *altáque* was an amphibrachys, *évinde* a dactyl. The rules of prosody alone taught them otherwise. Now when I think of all this; when I read the hexameters of a Praecilius, or the Political verses of a Tzetzes, or the drama of a modern Athenian, it seems to me almost preposterous to maintain that quantity exists even potentially in any modern language with which I am acquainted. When I was in Athens a few months ago, I met with tragedies which looked to the eye like the tragedies of Sophocles. The words were apparently ancient Greek; the metre was the senarius scanned according to accent. Reading them produced in me a strange dream-like sensation. The *a* of *σπλάγγνον* was long because it had the accent, so was the *a* in *αἶδε* for the very same reason. The *a* in *σπλαγγνεύσας* was short, because it was unaccentuated; so was the *a* in *αἶδει*. The *i* was short in *σφιγγός*, long in *σφίγγα*. To me it is the same with English. Neither my ear nor my reason recognises any real distinction of quantity except that which is produced by accentuated and unaccentuated syllables. To say '*Rapidly* is a word to which we find no parallel in Latin; the first short but accented, the second long but unaccented, the third short;' or,

'Sweetly cometh slumber, closing th' oerwearied eyelid

is a correct Virgilian hexameter;

Sweetly falleth slumber, closing the wearied eyelid,

contains two shocking false quantities,' conveys to my mind no intelligible idea. To me *rapidly* is an accentual dactyl, *cometh* and *falleth* alike accentual trochees; and nothing more; although I am of course aware that two or more consonants take longer time in enunciating than one. The argument of quantity is a mere paralogism arising from our misreading Virgil. '*Cóntemplate*,' says Rogers, 'is bad enough; but *bálcony* makes me sick.' Let us adopt Rogers' pronunciation and construct an Anglo-Virgilian verse:

Comfortably the world from a high balcóny contéplate,

Read now *bálcony* and *cóntemplate*, and we get assuredly 'two shocking false quantities.'

Of course I feel puzzled when I find so accomplished a critic holding such contrary opinions. He utterly repudiates accentual hexameters. Then after constructing several verses in what he calls Virgilian measure, he adds that to him the effect of such metre is not bad. And indeed if he goes back to the sixteenth century, he may find many zealous allies both in England and in France. Even so great a master of harmonious verse as Spenser was at one time enamoured of them. In a letter to his friend Gabriel Harvey he informs him that Mr Sidney and Mr Dyer 'have proclaimed in their ἀρείω πάργω a general surceasing and silence of bald rhymers...By authority of their whole senate they have prescribed certain rules and laws of quantities of English syllables for English verse, having had thereof already great practice and almost drawn me into their faction.' In another letter he goes farther. He likes Harvey's hexameters so well that he also 'enures his penne sometime in that kinde.' Thus for instance:

See ye the blindfolded pretie god, that feathered archer?
Wote ye why his mother with a veale hath covered his face?

'Do we not all recognise at once the movement of our new friend?'

Verses so modulate, so tuned, so varied in accent,
Rich with unexpected changes, etc.

But there were difficulties in the way; 'the chiefest hardness is in the accent...as in *carpenter* the middle syllable being used short in speech, when it should be read long in verse, seemeth like a lame gosling'...Yet 'why, a God's name, may not we, as the Greeks, have the kingdom of our own language and measure our accents by the sound, referring the quantity to the verse. I would heartily wish you would either send me the rules or principles of art which you observe in quantities, or else follow those which Mr Sidney gave me, being the very same which Mr Drant devised, but enlarged with Mr Sidney's own judgement and augmented with my observations, that we might both agree and accord in one, lest we overthrow one another and be overthrown of the rest.'

Think of the author of the *Faerie Queene* talking in this style! Imagine Demodocus writing to his friend Phemius in Ithaca, and telling him to send the rules which he observed in quantity, or else to accept those which Orpheus invented, Musaeus enlarged and he himself further improved; that they might not overthrow one another, and be discovered to be 'impostrous pretenders to knowledge' of quantity by those long-eared Achaians who had up to this time listened with rapture to their songs; but who might at length find out

that *ǎeide* with the accent on the first and the second long was only a 'lame gosling.' Was it in this way that Homer's verse was invented and handed down to him? Luckily the stiffnecked Muse was too strong for Spenser's logic, as she had been for Dante's, when he wished to discard the vulgar jargon for the sounding heroic of Virgil.

Italian too much resembles Latin not to have always entertained a pious horror of so ghastly a parody on its poor dead mother. In France such hexameters were once common enough; and at first sight it might appear that quantity was more possible in French than in most modern languages. The accent such as it is is very variable and is rather a heightening of the voice than an emphatic stress. The Latin accent, having become all-powerful by the destruction of quantity, must have displayed especial energy in creating the *langue d'oil*; so that after performing such feats as gathering up *semetipsissimum* into *même*, it would seem to have perished by its own intensity. The following is not a bad specimen of French quantity:

Rien ne me plait sinon de te chanter et servir et orner;
 Rien ne te plait, mon bien, rien ne te plait que ma mort.
 Plus je requiers et plus je me tiens seur d'estre refusé,
 Et ce refus pourtant point ne me semble refus.

The clear precision of the French intellect however soon recognised the truth and repudiated all such pedantic frivolities.

But the main object of the writer I am criticising is to put to shame the accentual English hexameter. He quotes from Virgil *Incipe, parve puer, risu cognoscere matrem*, and the following verses, and then triumphantly asks, 'Can anybody produce me an English hexameter resembling, in the succession of sounds, any one of these three lines? I think not. But if I shift the accents a little and write,

Incipe, parve puércule, risu noscere matrem.
 Matri longa tulérunt séx fastidia menses:
 Incipe, parve puércule, fác ridere parentes,—

do we not all recognise at once the movement of our new friend?

Why dost thou prophesy so my death to me, Xanthus? It needs not, &c.'

It is not I maintain the shifting of the accents, but the abolition of the caesura that changes each of these verses into two lumbering unrhythmical masses. Some of the most harmonious Latin verses have ictus and accent agreeing throughout. The most unrhythmical un-Virgilian verses in Ennius, Lucretius and the like, as I have remarked above, are not those where the accent is so arranged, but where it is distributed in such a manner that according to the laws laid down by J. S. we ought to have good symmetrical hexameters. Nay by slightly changing the verses just quoted I will make them quite rhythmical again, and yet the accents shall be precisely the same:

Incipe, parve, vidén, sine risu noscere matrem.
 Matri semper abhinc per séx fastidia menses:
 Efficé, parve, vidén, sine tê ridere parentes.

The accents are identical in both sets; for we know that *vidén* and *abhinc* are oxyton,

and *sine* and *per* atonic. If J. S. replies that his ear only acknowledges *vīden* and *ábhinc*; let him for once give these words the accent which he gives to *the while* and *awhile*.

Or let us apply his reasoning to cognate cases. What I would ask are the usual English metres but accentual adaptations of quantitative Latin measures, iambic, trochaic and the like? What is the English ten-syllable line of Shakespeare and Milton? Has not accent here replaced the Latin metrical beat, and is not caesura, essential to Seneca's verse, altogether unnecessary? or if it be said you cannot fairly compare a verse of five feet with one of six, let us take the present French Alexandrine. This may not be an attractive measure to an English ear. But we cannot deny that it has been brought to its present perfection by the labour and genius of centuries; and that it gives entire satisfaction to a nation exquisitely alive to beauty and precision of form. Now in it there *must* be no caesura; the sixth syllable *cannot* be the middle, *must* be the end of a word. Suppose I quote the opening lines of the *Œdipus Tyrannus*,

ὦ τέκνα, Κάδμου τοῦ πάλοι νέα τροφή,
τίνας ποθ' ἔδρας τάσδε μοι θαάζετε
ἰκτηρίους κλάδοισιν ἐξεστεμμένοι,

and reading them with the Anglo-Latin accent exclaim: 'Can anybody produce me a French Alexandrine resembling in the succession of sounds any one of these three lines? I think not. But if I shift the accents a little and write,

ὦ τοῦ πάλοι Κάδμον νέα τροφή, τέκνα,
ἔδρας τίνας τάντας ἐμοὶ θαάζετε,
ἰκτηρίους τούτοις κλάδοις ἐστεμμένοι,

do we not recognise at once the movement of our old friend, with whom we are all so painfully familiar?

Je chante ce héros qui regna sur la France, etc.'

I neither defend nor attack the English or German hexameter. No lengthened composition in either language, not even 'Hermann und Dorothea,' gives me full satisfaction. The monotony is too killing. But then what a dull heavy lumbering verse our English ten-syllable line was in the first half of the 16th century! What a glorious measure it soon became in the hands of Spenser, Shakespeare, Milton, and Dryden! Yet the five accents form the basis of all their infinite diversity of movement. With this analogy before my mind I can conceive it, though I do not know it, to be possible that in the hands of genius the English hexameter might be rendered even more majestic and sonorous than the iambic; might come in time to have somewhat of the same relation to it that the hexameter of Homer has to the senarius of Sophocles. However that may be, I feel convinced that six accentuated syllables must take the place of the six rhythmical beats, though the skilful and varied arrangement of some of these may give scope to great diversity of movement, just as the accent of our iambic is shifted about in certain places with such success by Shakespeare or Milton. Quantity must be utterly discarded; and longer or shorter unaccentuated syllables can have no meaning, except so far as they may be made to produce sweeter or harsher sounds in the hands of the master.

X. *On the Theory of Errors of Observation.* By AUGUSTUS DE MORGAN, F.R.A.S.
of Trinity College, Professor of Mathematics in University College,
London.

[Read Nov. 11, 1861.]

THIS paper is an attempt to simplify the mathematical treatment of the subject, mixed with a statement of the grounds on which, in my belief, it ought to rest. I touch only those heads on which I have something to say as to one or other of these points: and I make no remark on preceding writers, except so far as may be inferred from the following preliminary observations.

In this subject I fancy I have always seen a mixture of modes of thought and modes of treatment which makes it a difficult speculation, though easy of application in practice. Whether this or that be psychological postulate, result of experience, or deduction from one or the other, is often of harder determination than it ought to be: a difficulty sometimes arising from, or augmented by, the very circumstance on which facility of application depends. The peculiar pliability of the function e^{-ax^2} , which serves our turn be the law of facility of error what it may, is so dexterously used that we hardly know how much of any result is independent of it. This function makes its appearance only as a mathematical instrument. Had any other instrument been of more convenient use, it seems as if our results would have had another expression. I shall succeed in shewing that there is no possible choice in this matter, by introducing e^{-ax^2} into the representation of results obtained without any reference to it, expressed or implied.

The theory of probabilities professes to give the way in which belief in elements should affect belief in combinations. The word *probability* has two different senses, the collision of which is a grand source of confusion: it is used to refer both to the state of the mind, and to the external dispositions which are to regulate the long run of events: to our strength of prediction, and also to the capacity of circumstances to fulfil our prediction. I shall use the words *probability* and *facility*, as follows. Head and tail are to our minds of equal *probability*, so long as we know nothing to distinguish them: but to say they are of equal *facility* is to make an assertion involving points of symmetry, density, surface, &c. as regards the coin, and we know not what about the habits of the person who is to make the tosses. Accordingly, our theory does not, as many suppose, arrogate to itself a predictive character: it does not prophesy that in six millions of throws with a die, something near to one million will be aces. All it does is to justify to the mind the following alternative, Either very near to one million of aces, or determinate presumption, depending upon the amount of departure, against equal facility in the different faces. Such equality of facility is as likely as a pencil *line* or a perfectly rigid bar. When we talk of actually applying our theory to observations,

we mean that we carry with us into the field of practice a true knowledge of equal facility of positive and negative error, as to what its effects will be. What use we shall be able to make of this knowledge experience alone can tell us: theory has nothing to do with the answer to this question.

Every part of exact science has a defined foundation, upon which it is the *condition of science* that the superstructure shall entirely rest. The theory of probabilities postulates for its foundation $a + b$ equally probable—or to our minds similarly situated—cases, of which a favour one event, and b the alternative. Assent cannot be claimed to any fraction as expressing a probability, unless this derivation of its terms can be substantiated. Nevertheless, as in other branches of science, we find in ourselves a certain amount of rude, but not very inaccurate, knowledge of those details which it is our business to deduce from first principles. Geometry, for instance, does not give us more confidence in the proportion of the diagonals of squares to their sides than we began with. But the mischief of natural knowledge is this: with full confidence in a great deal of truth, we have also full confidence in a great deal of falsehood. Many persons begin by believing that doubling the side of a square doubles the *area* as well as the diagonal. And if we be liable to such mistake in judging of space, a matter in which our most unbiassed thoughts and our keenest perceptions keep watch upon one another, we must needs be in still greater danger in a subject of comparatively rough and infrequent experiment, in which the instruments of the mind have been trained under bias both of prejudice and self-love. The greatest stumblingblocks lie in the way when the argument is from the finite to the infinite, or from the infinite to the finite. I shall take an example of each.

From a sack of white and black beans, mixed and shaken, we take out a score, and find 13 white and 7 black. We naturally conclude that the sorts are in the proportion of 13 to 7, or not far from it: and also that we can have no reason to declare against that proportion on one side rather than the other. Is it not just as likely beforehand that the selected portion should belie the general average by excess as by defect? Before this is granted, we are tempted to recal the story of a Cambridge professor whom some living persons remember, who is said to have sturdily refused to concede that the whole is greater than its part until he saw what use his opponent would make of the concession. Let a person be required to stake upon his own statement of the proportion in such manner that the nearer he is to the truth the more he is to receive. He will do wisely to name 13 to 7. What odds then shall he offer that the next bean drawn is white? Surely, it will be answered, 13 to 7: nevertheless, this answer is wrong; he ought to offer 14 to 8.

Next, let A and B be arranged in every possible order, in infinite sequence, but so that in the long run A shall occur five times as often as B : that is, let the unending succession $AAAAAB, AAAAAAB, \&c.$ be made to take every possible variety of arrangement. Let an arrangement be drawn at hazard; what is the probability that its first letter shall be A . Any one can see, if he take the point of view, that we merely ask, on the supposition that in the long run A occurs five times as often as B , what is the chance of drawing A at the first trial. And the true answer is, five to one in favour of A . But how are we to meet the following reasoning? Let every one of the arrangements be made to have a duplicate; no two of the original arrangements being entirely alike. Of each related pair let one be headed

with a new A and the other with a new B : it is now an even chance for A . But have we not simply restored the original state of things? The addition of one more A or B does not alter the ratio of A s to B s in an infinite number. What was the original collection of arrangements except A followed by every possible arrangement and B followed by every possible arrangement? How then are there more ways of beginning with A than of beginning with B ? No beginner can answer this sophism: no proficient can make sure of having avoided the like, if he should take an assumption about the *long run*, or derived from the long run, until he has obtained verification from fundamental principles.

The science is essentially enumerative of equally probable cases, and draws all its conclusions from distribution of these cases under heads, and subsequent enumeration of the numbers under the several heads. The cases may be infinitely many, and it may require all the power of algebraic development or of the integral calculus to present the results of the enumerations: but this does not affect the truth of my assertion, though it places an array of symbolic reasonings between the beginner and clear perception of the fundamental method. In the subject of this paper there has always been a leaning towards the assumption of some complex results upon native evidence; especially on points connected with the average: and the *probable whole* has not infrequently been assumed to be a congeries of the *most probable parts*. This turns out, on proper examination, to be true in some very marked cases: and the conclusion is made welcome for its own sake, as well as for the letters of introduction which sound demonstration furnishes. But in the theory of probabilities, no less than in the conduct of life, if we open our houses to strangers upon the strength of pleasant looks and plausible stories, we shall certainly be swindled at last. That a probable whole must be composed entirely of probable parts is a fallacy of almost universal sway: it resembles the mistake made by Frankenstein, who constructed every limb and feature of his man upon the most approved model of separate beauty, and produced the ugliest monster that ever was seen. Stories which are throughout of the highest probability may be true; there are such truths: but those who note actual occurrences see that very complex wholes without improbable parts are extremely rare. The common mind weighs the probable against the particular improbable which the evidence seems to favour; it always forgets that in *à priori* reasoning, it is the probable against one or other of all the impossibles.

I now proceed to the statement of my own views :

If x be a quantity which may take various values, $x_1, x_2, x_3, \dots \lambda$ in number; we have $\lambda^{-1}\Sigma x, \lambda^{-1}\Sigma x^2$, &c. for the average value, average square, &c. If y, z, \dots be other quantities, having μ, ν, \dots values severally, it is clear that *average product* and *product of averages* are convertible terms, if combination of values may take place in any manner. Thus in $\Sigma x^\mu y^\nu z^\lambda$, we have $\lambda\mu\nu$ terms, which are the terms of the product $\Sigma x^\mu \cdot \Sigma y^\nu \cdot \Sigma z^\lambda$: and division by $\lambda\mu\nu$ shews that $\Sigma: x^\mu y^\nu z^\lambda = \Sigma: x^\mu \cdot \Sigma: y^\nu \cdot \Sigma: z^\lambda$, where $\Sigma: x^\mu$ means $\Sigma x^\mu : \lambda$, the average x^μ . Let us now examine the average of all the values of $(x + y + z + \dots)^k$, which are $\lambda\mu\nu \dots$ in number. Take a product of the type $x_a^\alpha y_b^\beta z_c^\gamma$, in which $\alpha + \beta + \gamma = k$: and let $\lambda\mu\nu \dots = N$. For given values of a, b, c , this term (with x, y, z) occurs in every value of $(x + \dots)^k$ in which $x_a + y_b + z_c$ is seen: that is, in $N:\lambda\mu\nu$ of the terms: and the same of every term of exponents

α, β, γ , whatever be its letters or suffixes. Hence, P being the coefficient of expansion of $x_a^\alpha y_b^\beta z_c^\gamma$, we find that $\Sigma x_a^\alpha y_b^\beta z_c^\gamma$,—where Σ refers to all terms of the type, from all the values of $(x + \dots)^k$ —has the coefficient $PN:\lambda\mu\nu$. Divide both sides by N , and we see that the multinomial theorem holds of averages. That is to say, if we expand $(x + y + z + \dots)^k$, and for each power of $x, y, \&c.$ write its average, we have the average value of $(x + y + z + \dots)^k$. This theorem lies hid in many cases of multiple integration.

Any number of values of a letter may be equal, so that by different sets of equal values, forming parts of the whole set, any probabilities of occurrence of any amount of value may be represented. If any letter have *balanced* values, that is, if $-a$ occur as often as $+a$, a being *any* one of the values, it is obvious that all the average *odd* powers of that letter vanish, and all the average products into which any odd power enters.

Thus if all the letters, or all but one, be balanced, we see that the average square of the sum is the sum of the average squares.

Let the quantities x, y, z, \dots increase without limit in number; but to avoid the prolixity of the language of limits, let us say that the number is infinite; and let the number be σ . As to the several values of the letters, those of any one may be finite or infinite in number; the results will be in no way affected by the transition from one supposition to the other.

First, let all the values of all the letters be positive. A term having h letters, with assigned exponents—of which the sum must be k —appears in each value of $(x + \dots)^k$ in as many ways as there are some sort of mutations of h out of σ : and this number is of the order σ^h . Accordingly, σ being infinite, we need only retain the terms in which h is greatest; and the same after substitution of averages. Now h is greatest, and is $= k$, when each letter enters only in the first power: and the multinomial coefficient is then $1.2.3\dots k$. Hence the average k^{th} power of $(x + \dots)$ is $1.2\dots k$ times the sum of all the products of the form $\Sigma:x \Sigma:y \Sigma:z \dots$ with k letters in each product. But, by the same reasoning, this is all that need be retained of $(\Sigma:x + \Sigma:y + \dots)^k$. Hence the following theorem:—All values being positive, and the number of letters which take value being infinite, the average of the k^{th} powers of the sum of values is the k^{th} power of the sum of average values.

By way of verification, let each of the σ letters be either 0 or 1: and let n_σ represent the number of combinations of n out of σ . The sum of the k^{th} powers of all values of $x + y + \dots$ is $0^k + 1_\sigma 1^k + 2_\sigma 2^k + \dots + \sigma_\sigma \sigma^k$, which is the operation $(1 + E)^\sigma$ performed upon 0^k ; where $E m^k = (m + 1)^k$. This is the operation $(2 + \Delta)^\sigma$; and $\Delta^n 0^k$ vanishing when $n > k$, the highest term is $k_\sigma 2^{\sigma-k} \Delta^k 0^k$, which,—since σ is infinite, and $\Delta^k 0^k = 1.2\dots k$,—is $\sigma^k 2^{\sigma-k}$. Divide by 2^σ , the number of values, and the average k^{th} power of the sum of values is $(\frac{1}{2}\sigma)^k$, or $(\frac{1}{2} + \frac{1}{2} + \dots \sigma \text{ terms})^k$, or the k^{th} power of the sum of the averages.

Another simple application of this theorem, easily verified by the integral calculus, is as follows. If $\phi a . dx, \phi(a + dx) . dx, \&c.$, the elements of $\int_a^b \phi x dx$, be multiplied together k and k , the sum of all the products is $\left(\int_a^b \phi x dx\right)^k : 1.2\dots k$.

Secondly, let all the letters be of balanced values. Every collection of terms of one type out of $\Sigma(x + \dots)^{2k}$ now absolutely vanishes, if any one or more exponents be odd: and every collection out of $\Sigma(x + \dots)^k$ now vanishes, if k be odd. The term of most letters in $\Sigma(x + \dots)^{2k}$ is that in which each exponent is 2, of all types that do not aggregately vanish. The number of letters is k , and the multinomial coefficient is $1.2\dots 2k : (1.2)^k$ or $1.3\dots 2k - 1 \times 1.2\dots k$. Hence the average $2k^{\text{th}}$ power of the sum of values, which I shall denote by A_{2k} , is $1.3\dots 2k - 1.1.2\dots k$ multiplied by the sum of all terms of the form $\Sigma : x^2 . \Sigma : y^2 \dots$ with k letters in each product. But $1.2.3\dots k$ multiplied by this product is all that is to be retained of $(\Sigma : x^2 + \Sigma : y^2 + \dots)^k$ or $\{\Sigma : (x + y + \dots)\}^k$ or A_2^k . Hence the following theorem:—If all the values of each letter be balanced, and the number of letters which take value be infinite, then A_{2k} being the average $2k^{\text{th}}$ power of all the values, we have

$$A_{2k} = 1.3.5\dots 2k - 1 . A_2^k.$$

As a verification, let each of the σ quantities take the values $+1$ and -1 . The sum of the $2k^{\text{th}}$ powers of the values is $\sigma^{2k} + 1_\sigma(\sigma - 2)^{2k} + 2_\sigma(\sigma - 4)^{2k} + \dots + \sigma_\sigma(-\sigma)^{2k}$, which is the operation $(E + E^{-1})^\sigma$ performed upon 0^{2k} . This is $\{2 + \Delta^2(1 + \Delta)^{-1}\}^\sigma 0^{2k}$, and its highest term is that which has $\Delta^{2k}(1 + \Delta)^{-k}$, of the terms of which only $\Delta^{2k}0^{2k}$ has value. The term to be retained is therefore $k_\sigma 2^{\sigma-k} \Delta^{2k} 0^{2k}$, or, σ being infinite, $\sigma^k 2^{\sigma-k} 2.3\dots 2k : 2.3\dots k$, or $1.3.5\dots 2k - 1 . 2^\sigma \sigma^k$. Dividing by 2^σ , the number of values, and remembering that the average square for each letter is 1, we see the verification of the theorem.

We may now adjust our supposition to the problems of our subject by supposing that each letter has an infinitely great number of continuous values, those infinitely near to v entering proportionally to the element of an integral, $\phi v dv$, so that the average k^{th} power of values of this letter is $\int \phi v . v^k dv$, taken from one extreme, as $-E$, to the other, $+E$.

If the extreme of integration give $\int \phi v dv = 1$, then, all the *original* values being equally likely, $\phi v dv$ represents the probability of a value taken at hazard lying between v and $v + dv$.

Let ϕv be called the *modulus of facility* of the value in question: I shall assume that $\int \phi v v^{2k} dv$, taken between extremes, is a finite quantity for every positive and integer value of k . The usual limits are $-\infty$ and $+\infty$: I shall denote $\int_{-\infty}^{+\infty}$ by \int . Should finite limits ever be in question, we must deduce out of our forms the consequences of supposing ϕv a discontinuous function of the form $(-\infty) 0 (-E) \phi v (+E) 0 (+\infty)$, where $\pm E$ are the limits of error.

Since ϕx is an even function, $\int \phi x . x^{2k+1} dx = 0$. And from this, and $\int \phi x . x^{2k} dx$ being always finite, it readily follows that $\phi^{(m)} x . x^n$ vanishes when $x = \pm \infty$, for all values of m and n , 0 included. Remembering $\int \phi x dx = 1$, the following results are easily obtained, m, a, k , being positive integers.

$$\int \phi^{(m)} x \cdot x^{m-a} dx = 0, \quad \int \phi^{(2m)} x \cdot x^{2m} dx = 1 \cdot 2 \cdot 3 \dots 2m;$$

$$\int \phi^{(2m)} x \cdot x^{2m+2k} dx = (2k+1)(2k+2) \dots (2k+2m) \int \phi x \cdot x^{2k} dx.$$

Dismissing for a while the idea of the number of quantities being infinite, I now ask what is the law of facility of value which gives $A_{2k} = 1 \cdot 3 \cdot 5 \dots 2k - 1 \cdot A_2^k$, for all integer values of k . We know one such law, which has the modulus $\sqrt{c} \cdot e^{-cx^2} : \sqrt{\pi}$: this, c being $(2A_2)^{-1}$, satisfies all the conditions.

If we could determine a function V , for which $\int V x^k dx = 0$ from $k = 0$ upwards, for all integer values, we might add this function to the modulus already obtained. We might almost deduce, *à priori*, that though such functions could be found if we could dispense with the *first* condition $\int V dx = 0$, the necessity of this condition is an insuperable barrier. This discussion will, however, be rendered unnecessary by the following mode of proceeding.

If to the quantity whose modulus is in question we add a constant, the character of that modulus is unaltered: ϕx being the modulus, all we have to say is that $\phi x dx$ now represents the probability of the value lying between $\text{const.} + x$ and $\text{const.} + x + dx$. If we add a quantity of variable value ξ , of indefinite modulus ψx , we may, at the close of our investigation, so change ψx that every case of $\int \psi x x^{2k} dx$ shall diminish without limit, from $k = 1$ upwards.

We suppose ψx to be an even function. The modulus of the sum, $\xi + x$, as we shall presently see, is $\int \psi(q-x) \phi x dx$, which, multiplied by dq , represents the probability of the sum lying between q and $q + dq$. Expanding $\psi(q-x)$ by Taylor's theorem, and paying attention to preceding conditions, we have for this modulus, $\{c \text{ being } (2A_2)^{-1}\}$,

$$\begin{aligned} & \psi q + A_2 \frac{\psi'' q}{2} + 1 \cdot 3 A_2^2 \frac{\psi'''' q}{2 \cdot 3 \cdot 4} + 1 \cdot 3 \cdot 5 A_2^3 \frac{\psi^{(6)} q}{2 \cdot 3 \cdot 4 \cdot 5 \cdot 6} + \dots \\ &= \sqrt{\frac{c}{\pi}} \int e^{-cx^2} \left(\psi q + \psi'' q \frac{x^2}{2} + \psi'''' q \frac{x^4}{2 \cdot 3 \cdot 4} + \dots \right) dx \\ &= \frac{1}{2} \sqrt{\frac{c}{\pi}} \int e^{-cx^2} \{ \psi(q+x) + \psi(q-x) \} dx = \frac{1}{2} \sqrt{\frac{c}{\pi}} \int e^{-cx^2} \{ \psi(x+q) + \psi(x-q) \} dx \\ &= \sqrt{\frac{c}{\pi}} \int e^{-cx^2} \left(\psi x + \psi'' x \frac{q^2}{2} + \psi'''' x \frac{q^4}{2 \cdot 3 \cdot 4} + \dots \right) dx. \end{aligned}$$

Expand e^{-cx^2} in powers of x , make the multiplication, and we have as many terms as there are cases of $\int \psi^{(2a)} x \cdot x^{2b} dx$. The integrations already described shew that the only terms independent of ψx are those which arise from the cases of

$$(-1)^k \frac{c^k}{2 \cdot 3 \dots k} \frac{q^{2k}}{2 \cdot 3 \dots 2k} \int \psi^{(2k)} x x^{2k} dx, \text{ which is } \frac{(-1)^k c^k q^{2k}}{2 \cdot 3 \dots k};$$

and that all the other terms give the forms (series) $\times \int \psi x \cdot x^2 dx$, (series) $\times \int \psi x \cdot x^4 dx$, &c. Hence, when these last integrals are diminished without limit, we obtain $\sqrt{c} \epsilon^{-c^2} : \sqrt{\pi}$ as the final modulus.

There is a want about the preceding investigation, and also about that of Laplace, which has never been complained of, and for a sufficient reason. It requires very high principle to scrutinise the accounts of a debtor who is always making mistakes in our favour, and always accompanies his statement by a cheque. All the methods in which ϵ^{-c^2} is employed give much better approximations than could have been expected from the demonstration, for even rather small values of σ . It would have been no matter of surprise, judging by the rejections of the process, if every decimal place of correct result had demanded a cipher in the numerical value of σ . Nevertheless, we get three places when we hardly want the second, and do not deserve the first. The reason must be sought at the beginning of the process: or rather presumption of the fact; for I can give no account of the matter which sufficiently explains the phenomenon. If we take any even function ϕx which gives $\int \phi x dx = 1$, and if $\int \phi x \cdot x^2 dx = A_2$, we have, far more closely than we could expect,

$$2 \int_0^\infty \phi x dx = \frac{2}{\sqrt{\pi}} \int_0^{x:\sqrt{2A_2}} \epsilon^{-t^2} dt.$$

Let all values be supposed equally probable, the most extreme case of a theory of errors. This supposes ϕx such a discontinuous function as

$$(-\infty) 0 \left(-\frac{1}{2a}\right) a \left(+\frac{1}{2a}\right) 0 (+\infty),$$

and gives $A_2 = (12a^2)^{-1}$, and

$$2ax = \frac{2}{\sqrt{\pi}} \int_0^{a\sqrt{6}\cdot x} \epsilon^{-t} dt.$$

Let $a = 1$. Then $x = \cdot 01$ gives $\cdot 02 = \cdot 027$; and $x = \frac{1}{2}$ gives $1 = \cdot 9$. Now try the case of uniformly descending facility, the limits being -1 and $+1$. This gives

$$(-\infty) 0 (-1) 1 + x (0) 1 - x (+1) 0 (+\infty);$$

also $A_2 = \frac{1}{6}$, and

$$2 \left(x - \frac{x^3}{2}\right) = \frac{2}{\sqrt{\pi}} \int_0^{\sqrt{3}\cdot x} \epsilon^{-t^2} dt.$$

Here $x = \cdot 01$ gives $\cdot 02 = \cdot 018$; $\cdot 05$ gives $\cdot 10 = \cdot 10$; $\cdot 1$ gives $\cdot 2 = \cdot 193$; $\cdot 5$ gives $\cdot 76 = \cdot 78$; and 1 gives $1 = \cdot 99$.

If we assume $\int_0^x \phi x dx = \frac{1}{\sqrt{\pi}} \int_0^{\sqrt{c}\cdot(x+bx^2+\dots)} \epsilon^{-t^2} dt;$

and if $\int \phi x \cdot x^k dx = A_k$: the first approximation, in which b , &c. are rejected, gives $c = (2A_2)^{-1}$; the second gives

$$c = \frac{5A_2 - \sqrt{(25A_2^2 - 7A_4)}}{2A_4} \quad b = \frac{c(1 - 2cA_2)}{3}.$$

I shall now enter upon the consideration of the subject from its first principles, making no use of what has preceded, but treating the observations made as finite in number.

When we have a number of discordant values from which to choose or construct a result, without any other knowledge than that of such similarity of circumstance of the different values as renders it impossible to prefer one to another, we naturally substitute the average for the true result unknown, upon a number of associations which are all covered by the phrase that this average is given by the observations, *one with another*. That the proper result should lie deep among the observations seems inevitable; and it is therefore some* kind of *average*, according to the general notion of the word. The mathematician, seeing that the balanced character of error makes it more likely that the sum of errors should be zero than *anything else*, however little likely in itself, sometimes claims to equate the sum of the errors to zero, and thence to deduce the most probable result; and thus he arrives at the average as the best substitute for the truth. But why does he give an exclusive attention to the sum of the *first* powers, when zero is also the most probable value of the sum of the *third* powers, or of any odd powers? This question cannot be answered. If small discordance only were supposed, the first power might have an easily understood claim of preference: easily understood, not so easily admitted in full. But the argument just stated, so far as it is valid, applies equally to all amounts of discordance.

The truth is that the average may stand upon a much stronger base of speculation than is usually given, namely, as that from which we have no reason for departure one way rather than the other. It is not merely the *mean value of all the given values*: it is also the *mean supposition of all possible suppositions* as to the mode of obtaining value. This may be shown in the following way.

A single observation is, before others are made, the most probable truth. If the second observation agree with the first, the common value is the most probable truth: and so on, so long as the observations show no discordance. If then $\phi(a_1, a_2, \dots)$ be the most probable result of the discordant observations $a_1, a_2, \&c.$, the function ϕ is subject to the condition $\phi(a, a, \dots) = a$. Now in every case in which this condition must be satisfied, whatever the intent of the process may be, it may be shown that the average $\Sigma a:s$ is the most probable

* A corndealer might dissent:—for to him the average ought to be something near the highest, if not above it. The harvest is, at the time of reaping, never better than an average, rarely so good. “If the fine weather should last three weeks longer, we may expect an average yield,” is the strongest admission ever made in the corn market. It is not until the next crop is so far advanced as to admit of gloomy prediction that we hear of “the abundant harvest with which Providence blessed the fields last year:” and this only as a covert hint not to expect the same again. All words are subject to strange mutations when they come into connexion with prices: as the daily accounts of the markets show. “I did not,” said the farmer, “get as much as I *expected* for those calves; and I *never thought* I should.” To “expect” is to “demand.”

The farmers have a right to the word *average*: for its origin is certainly agricultural. *Averia*, havings, or possessions, was a word applied to things in a lump: thus *averia ponderis*—whence *averdepois*—refers to the whole mass of goods sold by common weight, as opposed to the selected articles subject to troy weight. *Averia*, alone, meant precisely what a farmer now calls *stock*, that is, all the animals which a farm feeds. Afterwards the word was applied only to horses used in farm labour. *Averagium* was labour of the farm horses, &c. to which the lord was entitled, and for which the composition was the *averpenny*. *Averagium* also is of very old use in the sense of the loss of part of the cargo by sea or land thrown over the whole: and probably this is the use by which the word was brought into common life.

result, so long as we have nothing by which we can compare the goodness of two different forms of ϕ . If we want to know the most *unsafe* value, the one to be avoided above all others, we easily detect $\phi(a, a, \dots) = a$, and we shall conclude that the average of discordant attempts at this determination is the most probable *greatest falsehood*. If jurisprudence could establish the principle that the corporate guilt of a conspiracy is that of the conspirator, when all the conspirators are equally guilty; then jurisprudence would also be compelled to take the average guilt of variously guilty conspirators as the corporate guilt of the combination.

In the function $\phi(a_1, a_2, \dots a_s)$, symmetrical with respect to its subjects, make

$$a_1 = E + e_1, \quad a_2 = E + e_2, \quad \&c.,$$

E being taken at pleasure. Expanding by Taylor's theorem, and remembering

$$\phi(E, E, \dots) = E,$$

we have for the function

$$E + P\Sigma e + Q\Sigma e^2 + R\Sigma ee + S\Sigma e^3 + T\Sigma e^3e + U\Sigma eee + \dots$$

where by Σeee , for instance, we mean the sum of all terms of the form $e_a e_b e_c$, where a, b, c , are different suffixes. Now $e_1 = e_2 = \dots = e$ must reduce this identically to $E + e$; whence, s being the number of values given, we have

$$Ps = 1, \quad Q + \frac{s-1}{2}R = 0, \quad S + \frac{s-1}{2}T + \frac{s-1}{2} \frac{s-2}{3}U = 0, \quad \&c.$$

Q, R, S , &c. depending on T and s only. Now $E + P\Sigma e$, or $E + s^{-1}\Sigma e$ is $(a_1 + a_2 + \dots) : s$. Hence $\phi(a_1, a_2, \dots a_s)$ is $s^{-1}\Sigma a$ augmented by terms of which we have no knowledge whatever, either as to sign or value, and no means of getting any: we are therefore wholly without reason for supposing that the value of $\phi(a_1, \dots)$ lies on one side of the average rather than on the other, and must take this average as the most probable value *à priori*.

The average, then, is the most probable result so long as we know *nothing* of the law of facility of error: but this is only so long as the observations are either not made, or not disclosed. So soon as we see the *second* observation, we have some information about the law of error: not much, but *some*. The second blow begins a fray; the second instance begins an induction; the second observation begins a law of error. If you love life, says poor Richard, don't waste time; for time is the stuff that life is made of: if you value the results of the theory of probabilities, don't throw away presumptions, for presumptions are the stuff that results are made of. All information must be used up: and in known observations there must be information.

Nevertheless, we have arrived at this result. When the observations present little discordance, and differ by terms of the first order, the average can only differ from the most probable result by quantities of the second order at lowest. We may even predict that in all cases the terms of the second order must disappear; or $Q = 0, R = 0$. For if E be the absolute truth, and therefore $e_1, e_2, \&c.$ the real errors, we must suppose that a change of sign

in all the errors would change the side of the truth on which the most probable result lies. That is, we must suppose that the coefficients of all sums of the second, fourth, &c. orders vanish. This will presently be confirmed.

To deduce a law of error from observation with theoretical strictness, we should require to know, first, the truth, secondly, the individual results of an infinite number, σ , of observations. If τdv represent the number of the errors which lie between v and $v + dv$, it is then required that we should find what function of v is $\tau \div \sigma$. This function is the modulus of facility. But it will be foreseen that a preferable plan would be to determine A_{2k} , the average $2k^{\text{th}}$ power of an error, in terms of k , and then to investigate the form of ϕ which satisfies the equation $\int \phi v \cdot v^{2k} dv = A_{2k}$ for all values of k , A_0 being unity.

I now ask what supposition we can admit as to the values of A_{2k} . That A_{2k} should be finite for all values of k is obviously indispensable: no law of error which allows large errors to occur so frequently that the average tenth power, for instance, of an error, increases without limit with the number of observations, is worth consideration for comparison with our experience. Thus it would be absurd to contemplate any result derived from the modulus $1 : \pi(1 + x^2)$, in which even the average error, independently of sign, is infinite. Further, we cannot doubt that all observations are made under laws which, if the units of measurement be sufficiently great, must give A_{2k} diminishing without limit as k increases without limit. For the errors will then be *always* fractional parts of a unit, and A_{2k} must diminish without limit as k increases.

The final modulus, $\sqrt{c \cdot e^{-cx^2}} : \sqrt{\pi}$, does not satisfy this condition. Be the unit of measurement what it may, A_{2k} increases without limit with k . The transit observer has learnt to use and to be satisfied with a modulus which asserts and takes into theory the possibility of an error of a century at a single wire. Reckoning in seconds, let $c = 25$, which gives a probable error of little less than $0^{\circ}.1$ on each wire, and may nearly represent a tolerable observer. When k is great, A_{2k} is nearly $\sqrt{2} \cdot (k : c\epsilon)^k$. The average 100th power is about eighty-four thousand millions of millions, as great as it would have been if *every* error had been but little less than $1^{\circ}.5$. That is, errors of more than $1^{\circ}.5$ occur often enough to compensate those which are less, in the summation of 100th powers. Now,—not speaking of errors of clock-reading which, though errors, are self-detecting, and are corrected, and are truly no more connected with the errors we are speaking of than those which arise from setting the transit for a wrong star—we know that $1^{\circ}.5$ of actual error of *observation* is never made. The defence of our modulus lies in its sufficiency so far as A_2 and A_4 are concerned, beyond which we have no occasion to use it.

Since $\int \phi x \cdot x^{2k} dx$ is to be finite for all values of k , it is clear that ϕx must be of the transcendental character: and since ϕx must be even, e^{-x^2} would seem at once to be the form on which we must depend. This function made its appearance as the means of expressing results connected with high numbers, in the hands of De Moivre, in the second edition (1738)

of his *Doctrine of Chances*. Two extracts will show how nearly his forms approached to those of Laplace.

(p. 236.) ‘I also found that the Logarithm of the Ratio which the middle Term of a high Power has to any Term distant from it by an interval denoted by l , would be denoted by a very near approximation, (supposing $m = \frac{1}{2}n$) by the Quantities

$$\overline{m + l - \frac{1}{2}} \times \log . \overline{m + l - 1} + \overline{m - l + \frac{1}{2}} \times \log . \overline{m - l + 1} - 2m \times \log . m + \log . \frac{m + l}{m},$$

(p. 242.) ‘If, in an infinite Power, any Term be distant from the Greatest by the Interval l , then the Hyperbolic Logarithm of the Ratio which that Term bears to the Greatest will be expressed by the Fraction $-\frac{a+b|}{2abn} \times ll$; provided the Ratio of l to n be not a finite Ratio, but such a one as may be conceived between any given number p and \sqrt{n} , so that l be expressible by $p\sqrt{n}$, in which case the two terms L and R [equidistant from the greatest] will be equal.’

Let the modulus of facility be assumed to be

$$\phi x = \sqrt{\frac{c}{\pi}} \cdot \epsilon^{-cx^2} (p + qx^2 + rx^4 + sx^6 \dots).$$

Let it be found that a few at least of the observed averages $A_2, A_4, \&c.$ diminish rapidly.

Let $(2c)^{-1} = h$: then from $\int \phi x \cdot x^{2k} dx = A_{2k}$ we find (A_0 being unity)

$$\begin{aligned} p + qh + 3 \cdot rh^2 + 3 \cdot 5 \cdot sh^3 + \dots &= 1, \\ p + 3qh + 3 \cdot 5 \cdot rh^2 + 3 \cdot 5 \cdot 7 \cdot sh^3 + \dots &= A_2 h^{-1}, \\ 3p + 3 \cdot 5qh + 3 \cdot 5 \cdot 7 \cdot rh^2 + 3 \cdot 5 \cdot 7 \cdot 9 \cdot sh^3 + \dots &= A_4 h^{-2}, \\ 3 \cdot 5p + 3 \cdot 5 \cdot 7 \cdot qh + 3 \cdot 5 \cdot 7 \cdot 9 \cdot rh^2 + 3 \cdot 5 \cdot 7 \cdot 9 \cdot 11sh^3 + \dots &= A_6 h^{-3}: \end{aligned}$$

and so on. If $q, r, \&c.$ be small compared with p , we may make successive approximations, of which two will be sufficient, seeing that practice is well satisfied with the results of one. But practice does not know that one reason of her contentment with the first approximation is the practical accordance of the second with the first, in everything but value of constants. This circumstance tends to lessen our surprise at that pliability of the function ϵ^{-cx^2} which has been illustrated.

For first approximation we have $p = 1, p = A_2 h^{-1}$, or $(2c)^{-1} = A_2$. And we have $\sqrt{c} \cdot \epsilon^{-cx^2} : \sqrt{\pi}$ for the modulus. This is the well-known case: c is the *weight* of the observation; and the *probable error*—*critical error* would be a better name—is $\cdot 476936 : \sqrt{c}$.

The second approximation is obtained from

$$\begin{aligned} p + qh = 1, \quad p + 3qh = A_2 h^{-1}, \quad 3p + 15qh = A_4 h^{-2}, \\ \text{or } 3h^2 - 6A_2 h + A_4 = 0, \quad p = \frac{3h - A_2}{2h}, \quad q = \frac{A_2 - h}{2h^2}. \end{aligned}$$

Here h has two values, which become imaginary when $3A_2^2 - A_4$ is negative. We may reject this supposition: for when the first approximation is absolutely true, we have $3A_2^2 - A_4 = 0$, and we may presume that, in any law we shall have to represent, large errors are more infrequent than in the first modulus, so that A_4 , when second approximation is necessary, loses more than A_2 . The two values of h are greater and less than A_2 , so that the values of q have different signs, with values of p greater and less than unity. To determine which sign q should take, observe that $15p - A_6h^{-3}$ will, from the third equation, take a different sign from q ; so that

$$\frac{45}{2} - \frac{15}{2} A_2 h^{-1} - A_6 h^{-3}$$

will have a different sign from q . This quantity vanishes in the first approximation, and will, as above explained, become *positive* in any law we may have to represent. Let

$$A_4 = 3A_2^2 (1 - a^2),$$

a being positive. This gives

$$h = (1 + a) A_2, \quad p = \frac{2 + 3a}{2 + 2a}, \quad q = \frac{-a}{2(1+a)^2} \cdot \frac{1}{A_2}.$$

And $a = \sqrt{(3A_2^2 - A_4)} : A_2 \sqrt{3}$, by the magnitude of which we judge of the necessity for a second approximation.

Our modulus is now $\sqrt{\frac{c}{\pi}} \cdot \epsilon^{-cx^2} (p + qx^2)$, and for the chance of an error lying between $-m$ and $+m$ we have

$$2 \sqrt{\frac{c}{\pi}} \left\{ \int_0^m \epsilon^{-cx^2} dx - \frac{q}{2c} m \epsilon^{-cm^2} \right\},$$

remembering that $p + qh = 1$. Now $q : 2c$ being small, and m rather small in all cases in which ϵ^{-cm^2} is not, Taylor's theorem shows that the preceding is very close to

$$2 \sqrt{\frac{c}{\pi}} \int_0^m \left(1 - \frac{q}{2c}\right) \epsilon^{-cx^2} dx \text{ or } \frac{2}{\sqrt{\pi}} \int_0^{m\sqrt{c}\left(1 - \frac{q}{2c}\right)} \epsilon^{-t^2} dt.$$

$$\text{Now } \sqrt{c} \left(1 - \frac{q}{2c}\right) = \frac{1}{\sqrt{2A_2} \sqrt{(1+a)}} \left\{ 1 + \frac{a}{2(1+a)} \right\} = \frac{1}{\sqrt{2A_2}} \left(1 - \frac{3}{8} a^2\right),$$

nearly. Hence the probable error is

$$.476936 \sqrt{2A_2} \cdot \left(1 + \frac{3}{8} a^2\right),$$

which is that of the first approximation increased in the proportion of 8 to $8 + 3a^2$, or $8A_2^2$ to $11A_2^2 - A_4$. This change is small if the first approximation be good; for then $A_4 = 3A_2^2$ nearly: but if this be not the case, the alteration of the probable error is of importance.

The reader will observe that since q is negative, our second approximation involves the supposition that, when x is great enough, the modulus is *negative*, which is incapable of inter-

pretation, and will remain so until we have discovered* the *plusquam impossibile*. But the numerical effect is too small to require attention. I find that if we make the hypothesis that the error must lie between $\pm e$, with a modulus of the form $Ae^{-ce^2} (e^2 - x^2)$, the results, e being greater than unity, or not less, and c as large as it commonly must be, do not differ by anything at all appreciable from those of our second approximation.

I now proceed to consider the mode of deducing probable results. Let there be a number of functions of the quantities to be determined—say x, y, z ,—and of observed constants subject to error. Let P_1, P_2 , &c. be functions of x, y, z , and the constants, which would severally vanish if true values of variables and constants were used. Hence all value is error in P_1, P_2 , &c. Let it be known that positive and negative values of P_1, P_2 , &c. are equally likely, that is, let nothing whatever be known to the contrary; and let ϕP_n be the modulus of P_n , with reference to the constants; that is to say, fixed values of x, y, z , being used with observed values of the constants, the chance of the n th function lying between P_n and $P_n + dP_n$ is $\phi P_n dP_n$. If then $\xi dx, \eta dy, \zeta dz$, be the probabilities, *a priori*, of the variables lying between x and $x + dx$, &c., we know that the probability of this combination, after the observations, is $\xi\eta\zeta \phi P_1 \phi P_2 \dots dx dy dz dP_1 dP_2 \dots$ divided by the complete integral of this differential. The most probable conjunction of antecedents is therefore that which makes $\phi P_1 \phi P_2 \dots \times \xi\eta\zeta$ a maximum: and if all values of x, y, z , be *a priori* equally probable, in which case ξ, η, ζ , are constants, $\phi P_1 \phi P_2 \dots$ is to be a maximum. If $\phi_n P_n$ be $A_n e^{-\psi_n P_n^2}$, then $\psi_1 P_1 + \psi_2 P_2 + \dots$ is to be a minimum. This appears to me to be the only way in which probable value can be deduced from the acknowledged foundations of the theory. Any other method, however valuable as an illustration, would never have been allowed to impose a result contradictory of any result of *this* method. Accordingly, and treating of methods as demonstrations only, without reference to accessory value, I am much inclined to speak of all other methods as the slandered Caliph is said to have spoken of the Alexandrian books: "If in the Koran, useless; if not, pernicious: destroy them."

In practice ψP will always be a function of even form, and rapid convergence. We have then to make a minimum of $\Sigma(\psi''0 \cdot P^2) + \frac{1}{12} \Sigma(\psi''0 \cdot P^4) + \dots$ in which $\psi''0$ is always small compared with $\psi''0$. We begin by making $\Sigma(\psi''0 \cdot P^2)$ a minimum; or, P_x being $dP : dx$, we solve the equations $\Sigma(\psi''0 \cdot P P_x) = 0$, &c. For a second approximation, substitute the values of x , &c. thus obtained in $\frac{1}{6} \Sigma(\psi''0 \cdot P^3 P_x)$, &c. and solve

$$\Sigma(\psi''0 \cdot P P_x) + \left\{ \text{the value obtained for } \frac{1}{6} \Sigma(\psi''0 \cdot P^3 P_x) \right\} = 0, \text{ \&c.}$$

We shall probably always be compelled to estimate errors by taking the most probable value of each variable as the *reputed truth*, and taking the *reputed errors* derived from these values as the real errors committed. It may be worth while, nevertheless, to show the effect

* The negative probability may no doubt be an index of the removal from possibility of the circumstances, or of the alteration of data which must take place before possibility begins. But I have not yet seen a problem in which such interpretation was worth looking for. I have, however, stumbled

upon the necessity of interpretation at the other end of the scale: as in a problem in which the chance of an event happening turns out to be $2\frac{1}{2}$; meaning that under the given hypothesis the event must happen twice, with an even chance of happening a third time.

produced upon our probable results by the supposition of an extraneous and more accurate mode of estimating errors. For this purpose it will be sufficient to take the simple average of observations of one quantity. In this case the functions are $a_1 - x, a_2 - x, \dots, a_s - x$: and the first approximation, obtained by making $\Sigma\{\psi''_0(a-x)^2\}$ a minimum, gives for x the *weighted* average $\Sigma(\psi''_0 \cdot a) \div \Sigma\psi''_0$. Let T be a value which we see reason to prefer to this average for determination of errors, so that $a_1 = T + e_1$, &c.: whence we get

$$x = T + \Sigma(\psi''_0 \cdot e) (\Sigma\psi''_0)^{-1}.$$

Take $\Sigma\{\psi''_0(a-x)^3\}$, or $\Sigma\{\psi''_0(T-x+e)^3\}$, and substitute for $T-x$. We get for the next equation of approximation $\Sigma(\psi''_0 \cdot \overline{a-x}) + \frac{1}{6} V = 0$, where

$$V = (\Sigma\psi''_0 \cdot e^3) - 3 \Sigma(\psi''_0 \cdot e^2) \frac{\Sigma(\psi''_0 \cdot e)}{\Sigma\psi''_0} + 3 \Sigma(\psi''_0 \cdot e) \left(\frac{\Sigma(\psi''_0 \cdot e)}{\Sigma\psi''_0} \right)^2 - \Sigma\psi''_0 \left(\frac{\Sigma(\psi''_0 \cdot e)}{\Sigma\psi''_0} \right)^3.$$

When we can only obtain reputed errors, we have $\Sigma(\psi''_0 \cdot e) = 0$, and $T = x$. The first correction of the average is

$$x = \frac{\Sigma(\psi''_0 \cdot a)}{\Sigma\psi''_0} + \frac{1}{6} \frac{\Sigma(\psi''_0 \cdot e^3)}{\Sigma\psi''_0}.$$

I have verified the value of V by application of both Taylor's theorem and the reversion of series to $\Sigma\psi'(y+e) = 0$. Supposing the observations made under one law of facility, and turning back to our second approximation, in which the variable part of ψx is $-cx^2 + \log(p+qx^2)$, we find for the correction of the average the average cube of the reputed errors multiplied by $(q:p)^2 \div c$. This is a very small quantity, having the sign of the average cube: whence we infer, as we might have expected, that a positive average cube of error indicates a presumption that the average of observations is less than the truth; and *vice versa*.

The only law of facility under which the average is necessarily the most probable result is that in which $\Sigma\psi'(a-x) = 0$ gives $\Sigma c(a-x) = 0$ independently of the values of letters and of the number of the functions. Let $\psi'u = \chi(cu)$, and we see that $\Sigma\chi x = 0$ and $\Sigma x = 0$ must be true together for all values of x : and we know that χx must be an odd function. Hence $\Sigma\chi x + \chi v = 0$ gives $\Sigma x + v = 0$, or $\Sigma\chi x + \chi(-\Sigma x) = 0$, or $\chi(\Sigma x) = \Sigma\chi x$, which admits of no solution except $\chi x = ax$. Hence we deduce $\sqrt{c} e^{-cx^2} : \sqrt{\pi}$ as the only modulus which absolutely gives the average as in all cases the most probable result.

The greatest mathematical difficulty of the subject, the connexion of the sum of an unlimited number of errors with its modulus, may receive the following illustration of its demonstration, though of a character requiring much consideration, and at first of a repulsive aspect. It must be premised that an *observation*, as yet so called, need not be simply a result of perception, but may combine both thought and sense. It is enough that, being subject to error, positive and negative errors should be equally likely. Thus the average of a number of similarly situated observations may itself be considered as an observation, in anything hitherto laid down.

Further, it appears that the average of an unlimited number of observations, under one law of facility, must be the most probable value; must be in fact the true value. For if τ be the true value, the average of σ observations is $\tau + \sigma^{-1}\Sigma e$; and σ^{-1} and Σe both vanish. This can also be proved from the development of $\Sigma \psi'(a-x) = 0$. And next, we know that any observations which, independently of their value and number, give the average, weighted or not, as the most probable value, must be made under the modulus $\sqrt{c \cdot \epsilon^{-cx^2}} : \sqrt{\pi}$.

Now let there be any number of sets we please, each of an infinite number of observations, $\sigma_1, \sigma_2, \&c.$ in number. Let each of the averages, $M_1, M_2, \&c.$ be held an observation. We know that the average of the whole is the most probable result, namely, $\Sigma(\sigma M) : \Sigma \sigma$, independently of the number of sets of observations; consequently, the modulus of each is of the form asserted; but each is the average of an infinite number of observations. This argument is subject to the difficulty that $M_1, M_2, \&c.$ are equal, being each of them the truth in question. But if, instead of supposing the observations infinite in number, they were to be taken as only very great, and the several parts of the reasoning asserted approximately, instead of absolutely, the whole would become a demonstration of that kind which, though far from satisfactory, is cogent enough to throw doubt upon any contradictory conclusion, however arrived at, until absolute fallacy is detected. And this will never be done; for all the steps are substantially true, though requiring the introduction of limits for their explanation.

I shall not enter upon the special points connected with the method of least squares, in the common case in which the functions $P_1, P_2, \&c.$ are of the form $ax + by + \dots$. To this form all cases will be reduced in practice: for when we deal with $\phi(x, y, z)$ we generally know approximate values of x, y, z . If $x = x_1 + \xi, \&c.$, where $\xi, \&c.$ are small, our function takes the form $A + B\xi + \&c.$, powers and products being rejected as inconsiderable. And $\xi, \&c.$ become the subjects of discussion.

The *probable*—or *critical*—error depends more upon the universal use of the *final* modulus, $\sqrt{c \epsilon^{-cx^2}} : \sqrt{\pi}$, than any other part of the subject. No attempt has been made to *halve* any curve of error except the final curve. The modulus being ϕx , an even function, and $2 \int_0^\infty \phi x dx = 1$, the probable error is, approximately,

$$\frac{1}{4\phi} - \frac{\phi_{''}}{6 \cdot 4^3 \cdot \phi^4} + \frac{1}{12 \cdot 4^5 \phi^7} \left(\phi_{''}^2 - \frac{\phi \phi_{''''}}{10} \right) - \frac{1}{18 \cdot 4^7 \phi^{10}} \left(\phi_{''}^3 - \frac{\phi \phi_{''} \phi_{''''}}{5} + \frac{\phi^2 \phi_{''''}}{280} \right),$$

where $\phi, \phi_{''}, \phi_{'''}, \&c.$ are the values of $\phi x, \phi''x, \phi'''x, \&c.$ when $x = 0$. The all important theorem that the square of the probable error of the sum is the sum of the squares of the probable errors of the aggregants, is entirely the property of the final modulus. We see that it is not lost in the second approximation: but it would not remain true in the third. The mode of assigning the quantity of the probable error is the most unsafe part of the first approximation; that is, of the simple use of the final modulus. It may be wrong, as the second approximation shows, in any proportion between that of 8 to 8 and that of 8 to 11. When any use of caution is made of the magnitude of the probable error, it would be

advisable to increase it by one quarter before using it, if the number of observations be not very great.

I shall conclude this paper by some consideration of a point which is not connected with my present subject more than with other parts of the theory, but which requires notice, were it only for the confusion of language which has often prevailed in connexion with it. Geometers have long abandoned the notion of *indivisibles*, in which area is a congeries of an infinite number of lines; and length of points. We may imagine a square with every line parallel to two of the sides drawn in it. The logician must say that the square is *made up* of an unlimited number of equal parallels: the mathematician must refuse the assertion, in every sense the admission of which would compel him to add all these equal lengths into an area. The mind is reconciled to the refusal partly by the attention being necessarily directed to the consideration of length as a magnitude *per se*, and of area as another and essentially different kind of magnitude. But when we come to the conception which our minds must entertain of probability, we find that the *indivisibles* exist, without any distinct notion of descent from one *species* of magnitude to another *species*. Suppose the square to be a target, one point of which must be hit by the head of an arrow which ends in a mathematical point: such an arrow exists in thought as much as a geometrical line. That any one should name the parallel which will be struck is incredible; that any assigned parallel should be the one struck is not incredible; for it is not impossible. What then is the probability of striking a given parallel? It is certainly not an assignable magnitude: it is certainly not even an infinitely small quantity comparable to certainty in the sense in which dx is comparable to x . It is smaller than $(dx)^n$, however great n may be, the side of the square being unity; and, so far as we can make a symbol for it, that symbol must be $(dx)^\infty$. But it is not 0, according to usual interpretation; for only the impossible has the probability represented by 0. It is that *indivisible* of probability which a line is of an area.

Difficulties of this kind actually present themselves in problems, and are often made to lead to a process which is quite unintelligible except as derived from an admission of indivisibles. A function such as $\phi(x, y, z)$ is found to be as the probability that certain variables shall have exactly the values x, y, z : it is required to ascertain the probability that the variables shall lie between given limits, and instantly $\phi(x, y, z) dx dy dz$ is put down for integration. But if z be a function of x and y , then $\phi(x, y, z) dx dy$ is made to appear. I believe that the suppressed process is as in the following reasoning, which I take to be perfectly legitimate.

Let there be a line of a length a , from which a point is to be taken at hazard, and let the probabilities of that point being at distances x and y from the commencement be in the proportion of ϕx to ϕy ; required the probability that the point shall define a distance between p and q . Any infinitely small distance is made up of an infinite number of points, the number being proportional to the length. Let a be the number of points in dx : the probability of the point selected being in dx is maP , where P is between ϕx and $\phi(x + dx)$: say this is $ma\phi(x + \theta dx)$, ($\theta < 1$). This is subject to the condition $\int_0^a ma\phi(x + \theta dx) = 1$.

But ma may be written as ndx ; and the probability of the point defining a distance between x and $x + dx$ is $\phi(x + \theta dx)ndx$ divided by $\int_0^a \phi(x + \theta dx)ndx$; whence, by principles common to all questions of integration, we deduce $\phi x dx$ divided by $\int_0^a \phi x dx$. Let the problem be proposed as I have stated it, and I will defy any one to produce a solution without either the distinct recognition of indivisibles which I have made, or an assumption which hides it, something which "of course we may suppose."

In elementary writing the difficulty can often be avoided, and not merely evaded; especially the difficulty of the introduction of the differentials, and of the management of the differential of that quantity which is a function of the others. If ψy and ϕx be the moduli of y and x , the modulus of $x + y$ is $\int \psi(q - x) \phi x dx$, which, multiplied by dq , represents the probability that $x + y$ shall lie between q and $q + dq$. This may be obtained as follows. That the variables shall lie between $x + dx$ and $y + dy$ has the probability $\phi x \psi y dx dy$; and notions of integration with which we are perfectly familiar, and chiefly by geometrical application, give $\int \left\{ \phi x dx \int_{p-x}^{q-x} \psi y dy \right\}$ for the probability that $x + y$ shall lie between p and q . If $\int \psi y dy = \psi_1 y$, this is

$$\int \left\{ \psi_1(q - x) - \psi_1(p - x) \right\} \phi x dx.$$

The probability that $x + y$ shall lie between q and $q + dq$ is the differential of this with respect to q or $\int \psi(q - x) \phi x dx \times dq$. In the same manner we obtain the following form, which is more convenient in some respects than that commonly given. If $\phi_n x_n$ be the modulus of x_n , the probability that $x_1 + \dots + x_n$ shall lie between q and $q + dq$ is

$$dq \int \int \dots \phi_n(q - x_{n-1}) \phi_{n-1}(x_{n-1} - x_{n-2}) \dots \phi_2(x_2 - x_1) \phi_1 x_1 dx_{n-1} \dots dx_2 dx_1.$$

If those notions, sound or unsound, clear or confused, on which a point has been connected with a line, and a line with an area, as its *indivisible*, were carried into the consideration of magnitude in general, then $\frac{dy}{dx}$ would be called the *indivisible* of y . This would more than halve the number of letters in *differential coefficient*; but, independently of substantial objections to the introduction of the notion into elementary writing, a greater abbreviation is wanted. The length of the most common words is a serious obstacle, especially in teaching: and no body of educated men ever had the sense of the people at large, *quem penes arbitrium* merely because they choose that it shall be so. Popular usage will in course of time cut down the excellent words—excellent, because they say exactly what they mean—*numerator*

and *denominator* into *numer* and *denomer*, which the arithmeticians dare not do. That nothing shorter than 'the differential coefficient of y with respect to x ,' sixteen syllables of sound and forty-three letters of writing, can be found to express the ultimate element of the differential calculus, is a misfortune and a discredit. And more especially when it is remembered that this conglomerate of letters does not express the modern meaning of the symbol. This meaning is 'the limiting ratio of the increment of y to the increment of x ;' and, when first introduced, must be preceded by explanations which would allow 'the limiting ratio of Δy to Δx ' to be sufficient. It is a grand absurdity that the common *name* of the most common symbol, the least amount of phraseology which gives a complete designation, should be longer than its *definition* need be.

The reform which I should propose, if it were possible to create a discussion, would consist in expressing $dy : dx$ as 'the rate of y to x ' and 'the x rate of y ,' in abbreviation of 'the ratio of the rate of variation of y to that of x .' This is a most useful notion, and gives all the simplification of expression which can be imagined to be practicable.

A. DE MORGAN.

UNIVERSITY COLLEGE, LONDON,
July 31, 1861.

ADDITION.

In the last sentence a nomenclature is recommended which is simply *fluxional*. It is very much to be regretted that the notion of fluxions disappeared with the notation. Though satisfied that the doctrine of limits must be the basis of sound demonstration, I advocate the early introduction and use both of the infinitesimal and of the fluxional principles in aid of conception: and I observe that the fluxional principle begins to gain some currency in works published on the continent. It is not correct to make Newton the first proposer of the notion of magnitude as generated by flux: the *intension* and *remission* of the schoolmen were really positive and negative fluxions. I had made up my mind that Newton was more conversant with the schoolmen than is supposed, long before it was made known that the very scholastic *Logic* of Sanderson was a study of his early youth. It is impossible here to give any sufficient account of the old doctrine: I will content myself with one quotation. Nicolas D'Oresme (Horem, Oresmius) who died Bishop of Lisieux in 1382, wrote a tract *De Latitudinibus Formarum*, which was printed in 1482, 1486, 1515, and perhaps oftener. Though consisting of definitions and statements, without any calculus, there is in the work a certain prælibation of co-ordinates. The *latitude* being constant, we have a rectangle: the variation, therefore, of the latitude makes the difficulty of finding areas. Among other statements, we find that in every semicircle the intension of the breadth (which is nothing but $dy : dx$ positive) begins from the utmost

degree of velocity and terminates at the utmost degree of tardity in the middle of the arc. The remission ($dy : dx$ negative) begins from the same middle point with the utmost degree of tardity, and terminates with the highest degree of velocity. But lest any body should babble about this, utmost velocity is understood in respect of any other which is not of the same kind of figure, for it is not denied that one semicircle begins with a greater velocity than another. By how much greater the semicircle, by so much greater the initial velocity* and the final tardity. Here is a clear idea of fluxional velocity, and even of infinites and zeros in other ratios than that of equality. Probably more information may be found in two manuscript works of Oresmius mentioned as existing by Fabricius (*Bibl. Lat.*) with the titles *De uniformitate et difformitate intentionum* and *De proportione velocitatum in motibus*. I give this account as tending to shew that the fluxional principle is not the comparatively recent introduction of one mind, but the common property of an old and wide school of thinkers.

MARCH 17, 1862.

* In quolibet circulo incipit intensio latitudinis a summo gradu velocitatis : et terminatur ad summum gradum latitudinis tarditatis scilicet in medio puncto arcus. Remissio vero que incipit ab eodem medio incipit a summo gradu tarditatis et terminatur ad summum gradum velocitatis patet in figura c. d. Verumtamen ne possit aliquis garrulare intelligo summam velocitatem respectu alicujus alterius quod non est talis figure:

non enim nego quin unus semicirculus incipiat a majori velocitate quam alius. nam quanto semicirculus est major tanto incipit a majori velocitate intensio latitudinis sue et terminatur ad majorem tarditatem et e converso de remissione. (From the reprint in Tannstetter's collection of five tracts, *Vienne*, 1515; the quotation begins on the verso of *h* iii.)

XI. *On the Syllogism, No. V. and on various points of the Onymatic System.* By AUGUSTUS DE MORGAN, F.R.A.S., of Trinity College, Professor of Mathematics in University College, London.

[Read May 4, 1863.]

THIS paper contains the following points:—1. A criticism of Hamilton's system, as further explained in his posthumous work. 2. An explanation of the character of the system of Aristotle and his followers, which I affirm to have been *exemplar*. 3. The misconception of the character of this system by recent writers. 4. Enforcement of the right of *both* correlatives in any *pair*, and of all in any set, to equal fulness of treatment. 5. Application to the distinction of affirmation and *non-affirmation*; syllogism of indecision. 6. Deduction of the eight onymatic forms from purely *onymatic* meaning; alleged demonstration of the necessity and completeness of these forms. 7. *Restrictive* propositions, their affirmation and denial introduced in every view except the purely onymatic view, *whenever complete treatment of all correlatives is allowed*. 8. Completion of the exemplar system. 9. Extended comparison of the onymatic relations. 10. System of primary and secondary relations by copula of identification. 11. The same when the copula is any one of the simple onymatic relations. 12. The full system at which the Hamiltonian quantification aims. 13. The logical basis of extension and comprehension. [14. Addition on a recent phase of the controversy. December, 1862.]

The Society is by this time aware that any introduction of philosophy proper is also the introduction of controversy; which, though not necessarily *personal* in the modern sense, must be *ad hominem* in the old sense. Such dispute is now as nearly as possible excluded from mathematics and experimental physics: but it was not so of old. There was a time when the investigator in either was nearer to the foundation, and had more to do with the subject from the psychological point of view. It was then that Newton called philosophy—meaning physics,—a litigious lady, and said a man might as well be engaged in lawsuits as have to do with her. But though Newton and others—and Newton above all—have tamed this shrew in her dealings with mathematics and physics, she keeps her character as to all subjects in which first principles must still be probed, and questions of boundary must still be fought. And logic is a subject in which little more than a commencement of either has been made.

I have good hope that in this paper my personal part of a long discussion will come to an end. Since July, 1860, when Hamilton's *Lectures on Logic* were ably published

by Professors Mansel and Veitch, with various additions from the scattered papers of the author, I have had what till then I never had, the means of knowing with precision what the system is which has led me into fourteen years of controversial thought and writing: how this occurred will presently appear. The whole dispute differs from many others by an inversion of character. It often happens that a contest of principles degenerates into a duel: but that which I speak of took its rise in personal accusation, and was gradually refined and sublimated into a legitimate war of systems; perhaps because there was a mathematician on one side of it. Logic affirmed that Mathematics could not understand her principles, far less extend their development: that Mathematics was a cracker of shells who could not even so get at the kernels; having no more merit than belongs to those who walk straight in a ditch. Mathematics replied, in effect, that she could understand and would cultivate the field of Logic: that Philosophy, which confessedly could not bite the kernel, had settled nothing; while she had at least cracked the shell: and that, while she herself could either find or cut straight ditches, the only ditch in which Philosophy and Psychology had allowed Logic to walk—that into which the blind lead the blind—was one in which, for good reason, there was no walking straight at all. Such a suit is not abated by the death of one of the original parties: for it concerns undying things, and the undying part of persons. Hamilton's mode of controversy was conspicuously *ad hominem*: the adverse mind was his field of psychological observation: his ways and means lay very much in inference from his opponent's alleged errors to his opponent's intellectual organization. Though I need not follow the example all lengths, its existence will allow me a liberty of nearer approach than I should of my own mere motion have taken; and this liberty may be used with advantage to the subject. Character and motive being left untouched, I hardly see how such freedom can be entirely avoided: anatomists may fight a theory upon a third body; but psychologists are compelled to make some dissection of each other.

In order that I might finally dispose of Hamilton's system of enunciation and of syllogism, I found it expedient to challenge contradiction of a very curious assertion by appeal to a literary journal. It was necessary that I should somewhere state, and prove from the posthumous papers, that my distinguished opponent, the great logical teacher of his day, had actually laid down, as valid syllogisms, forms of argument which were mere paralogisms. I could not expect permission to *originate* such an assertion in these Transactions: though the Society may disavow all sanction of the facts and opinions to which it gives currency, leaving the responsibility on their authors, yet there are extremes both of fact and of opinion which the disavowal will not reach. Nor could I forget that my opponent had taken pains to put the Society and the University itself into the position of parties to the discussion, so far as it lay with him to compel their appearance. He had in fact refused, not merely to the Society, but to the whole academic body, from the Chancellor downwards, all escape from responsibility for my logical¹ heresies. I there-

¹ At the beginning of the article in the *Discussions*, presently noted, Hamilton says,—“If, as has been said, Mr De Morgan's Memoir may represent the Transactions, the Transactions the Society, and the Society the University of Cam-

bridge, then, either is the knowledge of Logic,—even of “Logic not its own,”—in that seminary now absolutely null, or I am publicly found ignorant of the very alphabet of the science I profess. The alternative I am unable to disown; the deci-

fore addressed two letters to the *Athenæum* journal (published July 13 and August 17, 1861) in which I exposed a curious apparent blunder relative to Aristotelian logic, and also one of the paralogsms above alluded to. I gave two months for denial, with notice that, if no denial were attempted, I should myself point out grounds of *extenuation*. I fully expected that editors, or pupils, or other disciples, would dispute my conclusions: but nothing whatever appeared. I accordingly wrote two other letters (published Nov. 2 and Dec. 28, 1861), in which I pointed out how hurry, illness, and halting between two systems, deprived the errors, which I then assumed to be undeniable, of the very gross and illiterate character which would have attached to them had they been deliberate. Further account of them will appear in the proper places. [Having waited more than a year, I again called the attention of the logical world to a point which nothing but testimony could settle, naming those from among whom I expected an answer. This plan was successful; and an account of the defence made will be found in an Addition. I have allowed the body of the paper to stand as it was written. *December, 1862.*]

My knowledge of Hamilton's system is derived from the following sources. I. A *prospectus* of the intended *New Analytic* issued in 1846, with *Requirements for a prize Essay*; both reprinted, the first with some omissions, in the *Lectures on Logic*. II. My correspondence with Hamilton in 1846-7, printed by him in 1847, with notes and additions, as part of our personal controversy. III. Mr T. Spencer Baynes's *Essay on the new Analytic*, the prize Essay of 1846, published in 1850, with additions, including a note by Hamilton himself. IV. A review of Hamilton, myself, and others, afterwards acknowledged by Mr Mansel, in the *North British Review* of May, 1851. V. A letter of Hamilton, dated August 7, 1850, forthwith published in the *Athenæum*, and reprinted in the *Discussions*. VI. An article¹ in the *Discussions* (1852) inserted probably at the last moment, under

sion I care not to avoid; and the discussion, I hope, may have its uses." The last words of this paper are—"So much for Mathematical Logic; so much for Cambridge Philosophy." I neither claim to represent the University, nor do I admit the alternative on which Hamilton risked himself: but, when I found I must prove that my opponent, though well knowing his alphabet, spelt new words incorrectly, I thought it right that the Society and the University should not give that faint appearance of sanction which this publication involves, until denial from Hamilton's followers had been challenged.

¹ This *hurried article*, as I shall sometimes call it, contains those quantities which are one and the same quantity, but of which the greater the one the less the other, and the apparent assertion that "some at least" is "possibly none." It seems to show excitement: its sarcastic photographs have stronger lights than those of preceding writings. As Hamilton had had the last word in the *Athenæum* journal eighteen months before, this is presumption of some new call to action. I surmise, from a stray sentence at the end, that the writer was roused, when his work was all but published, by information of the effect which my objections had produced south of the Tweed. After comparing a mathematician to an owl by daylight and a dram-drinker, Hamilton says,—“For a time, I admit, Toby Philpot may be the Champion of England.”

Those who examine the whole discussion in time to come, will note the manner in which his instinct made him feel that mathematics would destroy his fabric, unless he could first destroy mathematics.

Every proof of hurry in this article is an act of charity: the following is worth notice. Hamilton knew well (ix. i. 43) that in respect of "irrefragable certainty".....“Logic and Mathematics stand alone among the sciences, and their peculiar certainty flows from the same source.” He knew just as well that the contest between him and me turned wholly on the “forms of intelligence”—the necessary laws of thought—of an exact science. How then came he to object to me that a mathematician in “contingent matter” is like an owl by daylight? How came he thus to assert, by implication, that he and I had been arguing contingent matter? How came he to imply that the logical half of exact science is contingent? Except under this implication his assertion, supposing it true, would not help him. The answer is that he was in a great hurry, and pelted the mathematician with whatever came uppermost.

There is also hurry in Hamilton's appeal for help to Warburton's remark, that in his time the oldest mathematician in England was the worst reasoner in it. The person alluded to was Whiston: and no man of letters, writing very deliberately, would have taken Warburton as sufficient authority against

asterisked paging (621*—652*) and not altered—except as to paging—in the second edition. To get the page of the second edition, add 55 to that of the first. VII. Various editions of Bishop Thomson's *Outlines*, beginning with the second in 1849. VIII. The late Professor Spalding's *Introduction to Logical Science*, 1857. IX. The Appendixes, *passim*, to Hamilton's *Lectures on Logic*, 1860. If there be any other writings¹ which treat Hamilton's system at all extensively I am not acquainted with them. I shall quote these works by the numbers prefixed.

Some preliminary remarks are wanted upon the quantifying words *some* and *any*. The word *any* is affirmed by Hamilton (in V.) to be exclusively adapted to negatives. This cannot mean that *any* is unfit to be used in an affirmative: surely *any* one knows better than that. What is meant must be that no other word suits a negative, universally expressed, except *any*. I reply that all our quantifying words, though tolerably precise in affirmatives, are ambiguous in negatives. 'He has got some apples' is very clear: ask the meaning of 'he has not got some apples' in a company of educated men, and the apples will be those of discord. Some will think that he may have one apple; some that he has no apple at all; some that he has not got some particular apples or species of apples. Say 'he has not got all apples,' and some will take him as not possessing all the apples in existence, while others will understand that he has other fruit besides apples. 'An apple' and 'the apple' are perfectly clear: but 'he has not got any apple' is not free from occasional ambiguity.

The word *any*, when used *in a negative*, may have either a universal or a particular meaning: it may either stand for *any whatsoever*, or for a *certain or uncertain one or more*. It has been said that a healthy person who cannot eat *any* wholesome food does not deserve to have *any* food to eat. The first *any* is particular; it applies, *inter alios*, to a person who refuses cold mutton, though ready for any other digestible: the second *any* is universal, and excludes all victuals whatsoever. A person who has just dined heartily need not take *any* food (universal): a convalescent ought not to take *any* food (particular; beef tea, but not pickled salmon). Some will perhaps make it depend upon the verb used; they will see the universal in 'need not take any food', and the particular in 'ought not to take any food'. Some will make it a question of emphasis, laying stress on *any*, when the word is particular: but the ambiguity is there, let the grammarian and rhetorician treat it as they will. A logician may, if he please, postulate that *any* shall always have the universal sense in technical enunciation: Hamilton did not do so, but implicitly maintained that *any* is *always* universal. Accordingly, he asserted that 'No X is Y' is properly expressed by 'Any X is not any Y.' But though 'No fish is fish' be certainly false, 'Any fish is not any fish' is false or true, according as the second *any* is universal or particular. Choose

Whiston on the point in question. The two are now chiefly remembered by their several paradoxes: Warburton, by his maintenance of the absence of the doctrine of a future state from a permanent national religion being, *per se*, proof of Divine support; Whiston, by his acceptance of the Apostolical Constitutions as genuine and authoritative. Whiston seems to have reasoned well enough from his wrong estimate of certain writings: Warburton defended his peculiar thesis with great "ingenuity", say his admirers; but the word is one which admirers often substitute for "sophistry." There is

enough here to show that the condemnation of Whiston's *reasoning* upon the authority of Warburton, as a well-adjudged case, is probably nothing but hurry.

¹ There is an elementary work which is unfortunately spoiled by a misapprehension of the meaning of one of the forms of enunciation. But it will be a book of true method of inference to all who read the forms in the *exemplar* system of my second paper. The author's mistake consists in making 'Some X is not some Y' the simple contradiction of 'All X is all Y.'

what fish you please, it is not *any* fish: turbot is not trout. This is a slight error, easily prevented by a postulate.

The idioms of logical quantity have had very little consideration given to them. The word *some*, although it may have points on which logicians divide, has one case of subdivision upon which all logicians unite against the world at large. The distinction is that of *certain some*, and *some or other*: the first has an unknown definiteness, the second is truly indefinite. People in general incline to the unknown definite: the logician demands the true indefinite, but can in many cases follow the usual tendency. Whenever one term of a proposition is a definite, known or unknown, the *some* of the other term is the unknown definite. As in 'All men are [certain some] animals', or as in 'The men he spoke of were [certain some of those who were] here yesterday'. But when one term is truly indefinite, then *certain some* is not admissible in the other. Thus 'any men are [certain some] animals' is not true when 'any' implies unlimited selection out of 'all'. This is most obvious in the unusual exemplar forms: thus 'some animal is any man' would reduce mankind to an individual if 'certain' some were intended. In some subsequent parts of this paper the reader must watch himself on this point.

Logic may take liberties with language for the expression of thought: but she must not declare her alterations to be actual parts of speech. I fully understand and agree to the assertion that complete quantification may be made to allow simple conversion; that 'some X is not any Y' may infer 'Any Y is not some X'. Nevertheless, this cannot be admitted if *subjection* and *predication* remain notions attached to the subject and predicate: for predication is posterior to subjection; the subject comes *first* into thought, and the question of predication *follows*. For instance, 'some man is not any animal' is a falsehood: designate the man, and a search through the animals will find him. But 'any animal is not some man' is true: choose *any* animal, man or not man, and we can *then* show *some man* which he is not. In order to make this last proposition as false as its converse, the right of precedence must pass over to the second side with the term which originally had it. Of 'any animal', first chosen, 'some man' may be denied: of 'some man', first chosen, 'any animal' cannot be denied. The same thing in every case in which *some* comes into contact with *all* or *any*. Hamilton saw this, and it made him insist upon enunciation being pure *equation* or *non-equation* of subject and predicate, meaning identification or differentiation of simultaneously entering terms. But Hamilton had the faculty of fastening upon his whole species any use of language into which he had drilled himself. Thus (IX. ii. 294) he says—"Why, for example, may I say, as I think,—*Some animal is not any man*; and yet not say, convertibly, as I still think, *Any man is not some animal*? For this no reason, beyond the caprice of logicians, and the elisions of common language, can be assigned." If he should think it, he may say it: but in *common language*, and this with no elisions, 'Any man is not some animal' does not contradict 'Every animal is man', as he intends it should. For though every animal had been man, yet any man would not have been some animal. Common language makes subjects of terms and then predicates of them.

The word *some* has three distinct uses. First, as *non-partitive*; here it is only *not-none*, *some-at-least*, *some-may-be-all*. And this is the old sense of the logicians. Secondly, as

singly partitive; some-not-all, some-at-most, but without any assertion or denial about the rest. Thirdly, as *doubly partitive*; some-at-most, and the rest the other way. As Hamilton says, this¹ *some* is "both affirmative and negative", meaning that it makes any proposition which contains it both affirm and deny.

I cannot find any notice of the distinction between non-partition and single partition. The logicians are much given to halt between the two. Perhaps they would defend their course, as follows:—When we say "Some are", meaning "Some-not-all are", we say nothing at all about the rest. Perhaps also "the other some are". In what way then, do we differ from those who say "Some-perhaps-all are". Not at all, I reply, in the expressed "some" of particular subjects: but much in the implied "some" of particular predicates, in which "some not all" is of double partition by necessary inference. For example, say 'all men are *some* animals'; some-perhaps-all and some-not-all no longer give equivalents. If it be some-not-all, even though nothing were intended about the rest, the exhaustion of *man* contained in *all* forces double partition: the rest of the animals are *not* men.

Hamilton confronted *non*-partition, under the name of *indefinite definitude*, with *double* partition, under the name of *definite indefinitude*: the second phrase is defensible; the first is false contrast. Of *single* partition he takes no distinctive notice whatever. That his partition is really double cannot be doubted. His "some" is "both affirmative and negative"; he represents 'Some X is not any Y' as *inconsistent* with 'No X is Y'. This *must* mean that 'Some X is not any Y' tells us that the remaining X *is* Y. There is however no need to enlarge upon this: the diagrams and explanations (VI. 631*, 632*) are sufficient. Had Hamilton advocated single partition, all his syllogisms would have been valid; and my challenge would have had a host of respondents. One opponent nearly committed himself: he imagined that Hamilton really did adopt single partition; but he found out his mistake in time.

The system which was to form the base—or one of the bases, for Hamilton permitted the old system to exist alongside of his own—of the *New Analytic* consisted in applying the quantifiers 'some' and 'all'—in negatives 'any' universally taken—in every way to both subject and predicate: the word 'some' was intended to be doubly partitive, affirmation or denial of it was intended to convey denial or affirmation as to that 'other some' which in

¹ The common usage of mankind inclines to partition; even the affirmation of *none* is, whenever it can be so made, affirmation of *some* of the alternative kind. No person pays any respect to the doctrine that from negative premises nothing can follow: the negatives have their implied affirmatives. This happens from the earliest childhood: for example,

Jack Sprat could eat no fat,
His wife could eat no lean;
And so, betwixt them both,
They licked the platter clean.

How this arose we learn from the second verse, long lost to the nursery, but recovered by Mr Halliwell.

For (*i.e.* as implied) Jack ate all the lean,
And Joan ate all the fat,
The bone they picked quite clean,
And gave it to the cat.

The same ambiguity accompanies the mention of definite number. Thus 'four of them' may be any four, or certain four. The context only can decide. When we are told that a man had his horse out four times in one day, we must know what we are talking about before we can tell whether it was one or other horse, or one particular horse: and the same if the phrase were 'one of his horses.' If the statement be made in proof of his almost living on horseback, we shall certainly suppose various horses: if of his want of consideration for his poor beasts, we see that one only is meant. Here the difficulty is real: raise it upon a matter in which context is not required, and we pass into the region of jokes; as in the case of the man who is reported to have been reduced to despair of compliance with the prescription by seeing on the apothecary's label, 'Two of the pills to be taken three times a day.'

common language is 'all the rest'. The hypothesis was truly and consistently applied to every form of enunciation *except one*: and in that one, by a curious forgetfulness, the second side of the double partition remained unnoticed. According to Hamilton, 'Some X is not some Y' quadrates (VI. 632*) with *all* the other forms, is useful *only* to divide a class, and (IX. ii. 283) is consistent with *all* the other negatives; which is true of non-partition or single partition; but is false of double partition. It is a singular commentary on Hamilton's assertion of his system as *actually in thought* that his 'Some X is not some Y', systematically interpreted, is an equivalent of the Aristotelian 'Some X is some Y' being the simple contradiction of 'Any X is not any Y.' This I must prove at length.

Remembering that all Hamilton's propositions are simply convertible, and that his 'some' is both affirmative and negative, we see in 'Some X is not some Y' that all the other 'Some X is some Y', that 'Some Y is not some X', and that all the other 'some Y is some X'. Now all these four assertions are true when X and Y are¹ equivalents, when X is part of Y, when Y is part of X, and when X and Y have each part, and part only, in common with the other. Consequently 'Some X is not some Y' is true except only when X and Y are wholly external each to the other, and then false: it is therefore the simple contradiction of 'Any X is not any Y', and consequently the equivalent of the usual 'Some X is some Y'.

It would have caused but little alteration in the details of my criticism if this oversight had not been made. I now proceed to write down the forms of Hamilton's system, on all the three suppositions: the doubly partitive case being closely taken from himself (VI. 631*, 632*) in what appears to be his latest exposition.

Hamilton's forms.		Expressed in Aristotelian forms,		
	Affirmatives.	when doubly partitive.	when singly partitive.	when non partitive.
<i>Toto-total</i> ²	All X is all Y	Every X is Y } Every Y is X }	Every X is Y } Every Y is X }	Every X is Y } Every Y is X }
<i>Toto-partial</i>	All X is some Y	Every X is Y } Some Y is not X }	Every X is Y } Some Y is not X }	Every X is Y }
<i>Parti-total</i>	Some X is all Y	Every Y is X } Some X is not Y }	Every Y is X } Some X is not Y }	Every Y is X }
<i>Parti-partial</i>	Some X is some Y	Some X is Y } Some X is not Y } Some Y is not X }	Some X is Y	Some X is Y.

¹ Take notice that the mere application of *this* 'some' denies that its term is singular.

² This proposition was objected to by me as being only a compound of the *toto-partial* and the *parti-total*: this was when I supposed the partition to be wholly vague. Mr Mansel (iv. 116) declared "all X is all Y" to be a simple act of thought; and Hamilton (vi. 633*) supports this view. I now quote Hamilton's cooler thoughts, written without an opponent in the field (ix. ii. 292). "For example; if I think that the notion *triangle* contains the notion *trilateral*, and again that

the notion *trilateral* contains the notion *triangle*; in other words if I think that each of these is inclusively and exclusively [or perhaps *includedly* should have been invented] applicable to the other; I formally say, and, if I speak as I think, must say—*all triangle is all trilateral*." This is all I want: here is one proposition compounded of two. Hamilton remarks that when I declare this last to be compound (vi. 633*) I do not attempt to explain how *all* should be compound and *some* simple. I never said this, nor thought it: what I said was that the proposition X||Y is a compound of two *pro-*

Hamilton's forms.		Expressed in Aristotelian forms,		
	Negatives.	when doubly partitive.	when singly partitive.	when non partitive.
<i>Toto-total</i>	Any X is not any Y	No X is Y	No X is Y	No X is Y.
<i>Toto-partial</i> ¹	Any X is not some Y	Either toto-partial or parti-partial affirmative: any affirmative which contains <i>Some Y is not X</i> .	Some Y is not X	Some Y is not X.
<i>Parti-total</i> ¹	Some X is not any Y	Either parti-total or parti-partial affirmative: any affirmative which contains <i>Some X is not Y</i> .	Some X is not Y	Some X is not Y.
<i>Parti-partial</i>	Some X is not some Y	Cannot be false except when X and Y are singular and identical. [Should have been 'anything but a toto-total negative']		

In the *hurried article* (VI. 635*) we are informed in the text that the Aristotelian 'some' is 'possibly none'; and, in a note, that the Aristotelian 'not-some' does not definitely exclude 'none'. I suppose that if there be a point in which all preceding logicians agree, it is that *not-some* is *none*, and *not-none* is *some*. But I do not wish to give further attention to this extraordinary product of haste: I pass on to its source. When Hamilton combines *some-at-least* and *some-at-most* in one word, *some*; *not-all* and *not-none* are then of course constituents of the meaning of one and the same proposition. The ordinary logician, if he should choose to take 'some-at-most, possibly none' into his system,—as from Hamilton's words I suspect some must have done—will see two new particulars emerge, *equivalents* of the old ones, but not *identical* with them. For 'some-at-least-possibly all X is Y' is convertible with, 'Some-at-most-possibly-none X is not Y': and 'Some-at-least-possibly-all X is not Y' is convertible with 'Some-at-most-possibly-none X is Y'. If equivalence be for a moment confounded with identity, a person already accustomed to *not-none* and *not-all* in one proposition, might shape his language to the supposition that the logicians who use *none*

positions X))Y and X((Y; true when both are true; false when either is false. It is important to note that two wholes may compound into a third, without the parts of the two compounding into the parts of the third: I never said that all is compound of somes: but only that a proposition having two alls is compounded of two propositions having each one some.

¹ That disjunctively joined affirmatives should have the logical import of negatives, seems at first sight absurd: but other instances of it may be found; and I suspect that, under

limitation at least, it is a true canon. For another instance, I may cite my own form (·). It is a remarkable instance of the want of perception of analogies which characterises early speculation on all subjects—and which I look at with profit and amusement in my own earlier papers, nothing doubting that I shall in time do the same with this one—that Hamilton, who (VI. 650*) sneers at my disjunctively affirmative form of the negative (·), had not long before (VI. 632*) given two of his own negatives the same kind of form.

and *all* in two *equivalent* propositions, *none* in one and *all* in the other, use them both in *one and the same* proposition. I have pointed out, in the fourth of the letters alluded to, how an insufficient summary (IX. ii. 281) probably led Hamilton into the erroneous language of the hurried article (VI. 635*): it is hardly worth repeating here.

I proceed to the further consideration of the system before us. I shall apply my own notation to Hamilton's forms: thus $X \cdot (Y$ will designate 'Some X is not any Y '. It will be seen that, in the doubly partitive system, no one proposition simply contradicts another: though $) \cdot ($ and (\cdot) would have done it if (\cdot) had been truly brought under definition.

I shall take for granted that when any premises are given, *every* conclusion which those premises can yield must be drawn. I do not mean that in the common syllogism I must be noted as a conclusion whenever A is so: because I can be inferred from A . I mean that every possible conclusion must be stated, either immediately or mediately. I will grant to the framer of a system the right to be governed by the hypotheses on which he sets out, in the acceptance or rejection of any premises. But, should he accept a certain pair of premises, I will not grant him the right to stifle a part of the conclusion because he has no form in his system by which to express it: he ought to invent the form. Against any one who demands such a right I quote Hamilton, who insists upon it that language is to be found for all that is in thought: and I aver that when premises are put into the head, *all* the conclusion is in thought to all who can master it. There are two ways of offending against the reasonable principle stated above. First, by curtailing the conclusion to as much as can be expressed in the system. Secondly, by excluding combinations of premises because they have no conclusion except what cannot be expressed in the system, *and for no other reason*. Both these faults are committed: to which must be added the still greater fault of conclusions which do *not* follow from the premises.

The canon of validity laid down is that one premise must be affirmative (or both); and that one middle term must be universal (or both). I take this from the earlier writings, and by induction from the latest list of syllogisms: I shall not stop to consider the *general canon* (IX. ii. 285). It will be remembered that by affirmative and negative Hamilton refers to his own division, to his affirmatives which (all but one) contain negations, and to those negatives which are but disjunctively joined affirmatives. Speaking his language, and especially remembering that all his propositions are simply convertible, I affirm that both articles of his canon of validity are erroneous. As follows:

1. *Both premises may be negative.* Let us try $) \cdot (\cdot)$. If 'Any X is not any Y ' and 'Any Y is not some Z ', it follows that 'Some Z is not any Y ', and the remaining Z is Y , and therefore not X . Consequently, we have a right to the Aristotelian conclusion, 'Some Z is not X '.

2. *Both middle terms may be particular.* Let us try $)) ()$. If 'All X be some Y ' and 'Some Y is some Z ', whence 'Some Z (the rest) is not any Y ', it follows that all this remaining Z is not any X . Hence we have the Aristotelian conclusion, 'Some Z is not X '.

Here we see pairs of premises yielding conclusions from which we are debarred, because those conclusions are not such as require the doubly partitive '*some*' to express them. I now pass on to the syllogisms which *are* allowed admission (IX. ii. 287).

Hamilton arranges these under twelve heads. Each head has three syllogisms: one with both premises affirmative; two others formed by making one premise negative without alteration of quantities. Thus $) ()$ is accompanied by $) \cdot ()$ and $) (\cdot)$, as follows:

- $) ()$ All X is all Y and All Y is some Z.
- $) \cdot ()$ Any X is not any Y and All Y is some Z.
- $) (\cdot)$ All X is all Y and Any Y is not some Z.

The negative syllogisms take the number of the positive one from which they are derived, with the letters a and b. The canon of inference may be stated as follows:—When one premise is $) ($ the form of the other is that of the conclusion: in every other case the erasure of the two middle spiculæ shows the form of the conclusion. I now make a table, adding a word of necessary remark in certain cases.

	a		b	
I	$) (($	*	$) \cdot (($	*
II	$(())$	False	$(\cdot ())$	Incomplete
III	$) ())$	*	$) \cdot ())$	False
IV	$((() ($	*	$(\cdot ((($	*
V	$) (((($	*	$) \cdot (((($	†
VI	$))) ($	*	$) \cdot)) ($	*
VII	$((()$	False	$(\cdot (()$	Incomplete
VIII	$()))$	False	$(\cdot)))$	†
IX	$) (()$	*	$) \cdot (()$	False
X	$()) ($	*	$(\cdot)) ($	*
XI	$((((($	†	$(\cdot (((($	False
XII	$))))$	†	$) \cdot))))$	False

Of 36 syllogisms, 21 have no error either of commission or omission: which arises as follows. Those marked (*), 15 in number, are safe because they contain $) ($, the sign of equivalence. Let the other signs have any degree of absurdity, or even of contradiction, any one of them joined with $) ($ only means that one of the terms is to be extracted, and an equivalent inserted in its place: consequently $X) (Y (\cdot Z$, for example, must give $X (\cdot Z$, let $(\cdot$ mean what it may. Two others, marked (†), contain and conclude with the vague form (\cdot) , which “quadrates with all the rest”; and their principle is that some (when singly partitive) of the *part* is an equivalent of some of the *whole*. Remember that Hamilton did not intrude double partition into the meaning of (\cdot) . Four more, marked (‡), involve “some” only in one term of a universal affirmative, in which double partition is of the same effect as single. All the rest—being precisely all those which give working effect to the peculiar *differentiæ* of Hamilton’s system,—are either false or incomplete: eleven false, four incomplete. [I proved this in detail, in due compliment to the reputation of the proposer: but I omit¹ the proofs, because I find that the point is not to be contested. *December 1862.*]

¹ In the *Athenæum* journal I took for my instance a case of all lawyer; any lawyer is not any stone; therefore some man IV. b, which I called the *Gorgon* syllogism. “Some man is (i.e. lawyer) is not any stone (i.e. all the rest are stone).”

I now ask what is the real basis of this system? It is formed on what I call the *pepper-box* plan; *all* and *some* are shaken out upon subjects and predicates in every possible way. I am a decided advocate for this process, as a preliminary mode of collecting materials: and I have now before me 512 modes of enunciation—and this only an instalment—obtained by using the pepperbox with some of the pairs of correlative notions which are scattered through the systems. It would have been well for logic if Aristotle had followed this plan. But it is an error to assume that because certain junctions of correlative concepts give an incomplete system, therefore the introduction of all the remaining junctions must complete that system. Any person who makes this supposition may become liable to the remark made by Hamilton upon Aristotle—and which I now make upon himself—that he commenced his synthesis before he had completed his analysis.

As soon as the distribution of ‘all’ and ‘some’ had been made, and also introduction of the partitive sense of ‘some’, very slight attention would have shown that the enunciative forms present an imperfect system of the kind which I called *complex* in my *Formal Logic*, and *terminally precise* in my third paper. Contrary or privative terms being refused admission, it would have been seen that there are *five* terminally precise relations; or rather, three terminally precise, and two of which one terminal ambiguity is due to the refusal of privative terms, which refusal prevents statement of the relation in which one name stands to the contrary of another. On the principle—which I will not argue further, for with great personal respect for its deniers, I tell them their denial is absurd—that no *system* of enunciation can be admitted to the name until it is as powerful at denial as at assertion, and at assertion as at denial, five contradictions ought to have been introduced. The conjunctive propositions should have brought in their disjunctive denials; and the whole would then have stood as follows. I use both Hamilton’s language and my own; but the symbols are now to express Aristotelian forms.

1. All X is some Y : X toto-partially inclusive of Y : X a sub-identical of Y : X \cdot Y, conjoined of X \cdot Y and X \cdot Y. The contradiction is ‘Either X \cdot (Y or X \cdot Y), which I denote by X \cdot (Y.

2. All X is all Y : X toto-totally inclusive of Y : X an identical of Y : X \parallel Y, conjoined of X \cdot Y and X \cdot (Y. The contradiction is ‘Either X \cdot (Y or X \cdot Y’, denoted by X \cdot), \cdot (Y.

3. Some X is all Y : X parti-totally inclusive of Y : X a superidentical of Y : X \circ (Y, conjoined of X \cdot (Y and X \cdot (Y. The contradiction is ‘Either \cdot Y or X \cdot Y’, denoted by X \cdot), Y.

4. Any X is not any Y : X toto-totally exclusive of Y : X an external of Y, X \cdot (Y. The contradiction is X \cdot Y, which, as explained, should have been the partipartial negation, ‘Some X is not some Y’ of Hamilton’s system.

[Mr Baynes (*Nov.* 22, 1862) cheerfully accepts this syllogism under the name I have given it, declares it valid, and will defend it if it be “seriously assailed.” This is hasty writing: he means that he will defend what *he* supposes Hamilton to

have meant, not what *I* suppose him to have let pass. But what Mr Baynes takes for Hamilton’s meaning needs no defence; what I suppose him to have passed cannot be *seriously* assailed. *December*, 1862.]

5. Some X is some Y : X partipartially inclusive of Y : X a *complex particular* (*Formal Logic*, p. 66) of Y : or X (·(·)·) Y, conjoined of X (·(Y, X (·) Y, X ·) Y. The contradiction is 'Either X)) Y, or X)·(Y, or X ((Y', denoted by X)); ((Y.

These enunciations constitute the system¹ at which Hamilton was aiming, but which permutations of 'some' and 'all' did not and could not reach. I do not think it worth while to set out all the syllogistic forms: these are best obtained by resolution into simple pairs of premises. I shall presently have occasion to exhibit a more perfect completion.

I now proceed to inquire how this system was received in the time preceding the publication of Hamilton's *Lectures*. The day will come when, but for such hints as I now give and the explanations which they will directly or indirectly produce, an inquirer into the early history of the expressed quantification of the predicate would be in serious difficulty. From 1847 to 1860 he will trace a stream of eulogy and controversy, of which Hamilton's quantification is the subject: but not a direct word does either advocate or opponent let fall about this quantification containing a very striking departure from Aristotle and his followers. Hamilton himself gives no information until 1852, when he announces his plan in terms which, to the inquirer I am supposing, will appear as clear as any terms could be: but still neither friend nor foe seems to know more about it than before. It is not until after 1860, when those remains were published which had for eight years been known by nearly sufficient extract, that all Hamilton's admirers are suddenly and publicly challenged to show that his real² system does not lead to mere paralogism: which not one of them undertakes to do. What does all this mean? Is it reserve? Is it misapprehension?

Previously to 1852, Hamilton did not indicate intention to depart from Aristotle in the meaning of the quantifying designations. In his *Prospectus* (1846) he announces that he is to put the key-stone on the Aristotelic arch: not a hint is given that the buttresses are to be changed. In his correspondence with me, not a word of so much, as

¹ It is clear that Hamilton never examined the syllogism upon the doubly partitive hypothesis. To my mind by far the most probable hypothesis is that, after the attack of illness which he never wholly recovered, he really believed that he had examined the syllogism: a sudden interruption of this kind often has strange effects in the way of confusion between what had been done and what was to be done. This supposition receives some confirmation from the note at the end of the table of propositional relations—'The preceding table may not be quite accurate in details' (IX. ii. 284, VI. 637*). Such a memorandum in a private paper is for personal use: it was copied into the hurried article (VI.), which means that no deliberate examination had taken place up to 1862, even of the table of propositional forms. Now it is clear that a minute verification of the cases of syllogism must have either ended in, or been preceded by, such examination of the table of enunciations as would have led to the erasure of the note.

² There is another point, which I cannot decide. Hamilton taught his own system publicly from 1840 downwards. What use of 'some' did he adopt? Neither he himself, nor Mr Baynes in his *New Analytic*, nor Bishop Thomson in his

Outlines, nor Mr Mansel in his edition of the *Lectures on Logic*, give any information on the point. I put the question in my letters to the *Athenæum*, but no reply was made. I cannot bring myself to think that my acute opponent actually taught, year after year, a system of syllogism containing a cluster of paralogisms. I lean strongly to the supposition that he retained the Aristotelian sense, or made no further departure than the singly partitive meaning: but if this be the fact, what hinders those who can from establishing it? I repeat the question again, and I trust that, if the point can be cleared up, those who have the means will not allow me to be the only person who shows interest in Hamilton's literary fame. For the honour of Scotland, a land noted for the logical turn of its sons, the question should be settled. Should judgment at last go by default, the decision must be that for sixteen years undetected paralogisms formed a third part of the system of syllogism taught in the University of Edinburgh as the "key-stone of the Aristotelic arch." [Mr Baynes replied satisfactorily on this point, as will appear in the Addition. I leave this note as showing what I thought on the subject when this paper was communicated. December, 1862.]

allusion. In my *Formal Logic* (1847) I published my suspicions of what the system was, in which I made it clear that I supposed the non-partitive quantity to be the one adopted. This was soon followed by Bishop Thomson's second edition (1849) and by Mr Baynes's *Essay* (1850), the first containing information communicated by Hamilton himself, the second a student's account crowned—and augmented—by Hamilton himself. But, though both writers drop a sentence or two which seem to hint that their own system is the singly partitive—most writers, as already noticed, occasionally use at least a singly partitive phraseology in their preliminaries—not a doubly partitive syllable escapes from either. In my second paper (1850) I made it still more apparent that I attributed only the non-partitive sense. Hamilton made an indignant remonstrance (V.) against the use of “all” which I attributed to him: but not a word about “some”: [it turns out (see Addition) that he took me to be using ‘some’ in his own new sense, which first appeared in print with his criticism on my supposed objections to it. He had forgotten his own previous silence.] His editors (IX. ii.) say that his notation had a uniform¹ import from 1839-40 onwards.

Mr Mansel (IV. 113, 116) gives evidence (1851) of having on his mind the impression that Hamilton differs from Aristotle: but not a syllable is there in his article from which we can infer more than single partition, or at most the double partition which single partition forces out of the universal affirmative. I feel justified in so much use of our private correspondence as to state that he has informed me that all his sources were in print. He makes no allusion to Hamilton's pamphlet (II.), probably because he did not, any more than myself, gain any knowledge of the system from this source. I rest perfectly satisfied, until contradicted, that Mr Mansel had no complete idea of the double partition, nor of its consequences. As one editor, indeed, he has given me and others the means of arriving at knowledge of the whole case: but both editors, in their short preface, imply a *caveat* against being supposed to agree with their principal in all points. Mr Mansel's article is a valuable repertory² of the non-mathematical logician's objections to the results

¹ They say that “this” (p. 278) was his uniform import. By the preceding sentence it appears that “this” is “the meaning which the author attached to them [the symbols] on the new doctrine.” These symbols, therefore, never had more than one meaning; but they certainly were doubly partitive at last; therefore they were doubly partitive throughout. But the diagrams on which (and on their explanation) the note is made do not agree with the later diagrams (vi. 632*): the partial negatives, for example, are not disjoined affirmatives; and the whole gives more than a suspicion of the singly partitive sense. I hope that the second edition will be more precise on this point.

In the text I give nothing but facts. My own belief is that Hamilton neither publicly taught, nor privately communicated to any of those who have since acknowledged communication, any thing beyond the singly partitive system. If, as his editors seem to suppose,—and not against any presumption which I can bring forward—his double partition was elaborated by 1846, I feel almost sure that he intentionally reserved it. He had a perfect right to do so; the same right which Titus Oates's fox had to carry a stone over the brook to see if the ice would bear, before he attempted to carry over the goose.

But such reserve always brings perplexity into history: Hamilton has made it easier to cook his goose than to write its biography.

The following gives a strong suspicion—even more—of reserve in 1850, abandoned in 1852. In (v.), he says, “The language I use is that of the logicians; only the quantity of the predicate, contained in thought, is overtly expressed.....” In the reprint of this letter (vi. 626*) he adds to the words “some is not”, the following in brackets—“[Some is should, however, have been held its direct and natural result; for, as we shall see, two particulars in the affirmative and negative forms, ought to infer each other. Compare p. 635*, sq.]” [This makes the forgetfulness above noted very strange.]

² I quote at length the chief point of reference:—“Before quitting this part of our subject, we will describe the principle of Mr De Morgan's complex syllogism, as that part of his system which comes in some degree into rivalry with the quantified predicate of Sir W. Hamilton, which we are about to examine. When we say that the latter accomplishes all the ends attained by Mr De Morgan, with a vast superiority in clearness and simplicity as well as in accuracy of thinking, we have said all that is necessary in the way of criticism.

of mathematical habit: and I confidently predict that it will often be cited as such when the number of those who stow both logic and mathematics in one head shall be greater than it now is. So far I have not produced a single hint of double partition. When I examined the late Professor Spalding's work (1857) I could not trace a phrase which was not perfectly reconcileable with the Aristotelian sense, or at most with single partition. On re-examining my copy for the purposes of the present paper, I found inserted a number of the *Edinburgh Weekly Review* (July 18, 1857) containing an account of Mr Spalding's work, and citing¹ him as among the chief objectors to Hamilton's junction of "some at least" and "some at most."

Lastly, I mention myself, who might have been expected to have read the whole riddle at once in the publication (VI.) of 1852. But I, at that time, had good reason to feel estopped, as the lawyers say, from all interpretation of Hamilton's meaning: the reason is described in the Appendix to my third paper. I found that, in spite of the most distinct assertions, as well on the part of Hamilton as of his expositors, that 'all' is the exponent of universal quantity, I was wholly in the wrong for not divining that 'any' must be used in every² negative proposition (V. *passim*). The sarcastic pictures caused the article (VI.) to be to me, so long as its author lived, a joke and nothing else; I mean that whenever I sat down to read in earnest I was always captured by the fun. And when, at last, I gave it serious examination, my disinclination to interpret was augmented. When I saw that

Mr De Morgan refuses to quantify [Mr Mansel means *partitive-ly*] the predicate in a single affirmative proposition. Accordingly, the universal affirmative, all X is Y, may form part of two complex propositions, either 'all X is Y, and all Y is X', or 'All X is Y, and some Y is not X'. Hence a syllogism in Barbara which, in Sir W. Hamilton's system, would be expressed in the form 'All X is some Y, all Y is some Z, therefore all X is some Z', becomes in Mr De Morgan's hands the following complex reasoning [a hasty word; *expression* must be meant: for Hamilton's syllogism contains all this *reasoning*; and this by the partitive force of 'some']:

All X is Y, and some Y is not X.

All Y is Z, and some Z is not Y.

Therefore, All X is Z, and some Z is not X.

The reader who is desirous of further details must seek them in Mr De Morgan's own work. Those who will take the trouble of comparing his fourth and fifth chapters with the system we are about to describe, will, we are convinced, discover abundant grounds to justify our preference for the latter. We have followed Mr De Morgan through a tedious journey, during which we have more than once had occasion to express our respect for his talents, and our regret at their perversion. We take leave of him in the words of an eminent logician and mathematician:—"Enimvero quæ confuse tantum cognoscuntur, ea sæpius confunduntur, at adeo casus similes videantur quæ sunt dissimiles, et secundum ideam confusam qui agit, facile omittit quibus vel maxime fuerat opus. Atque ideo logica naturali instructus in applicatione sæpissime aberrat. Exemplo nobis sunt illi qui, in mathesi cum laude versati, methodum mathematicam extra eandem perperam applicant, etsi sibi rem acu tangere videantur." (Wolf, *Philosophia Rationalis*, Proleg. § 19)." I suspect that the text of the last two

sentences is corrupt: and I propose conjectural emendations. Remember that all that relates to *quantity* is mathematical; for *naturali* read *sine mathematica*, for *cum laude* read *minus*, for *extra eandem* read *inscitiâ naturali*.

¹ "Unless indeed objection be taken, as is done by some of them [his disciples], and particularly by Professor Spalding, to Sir William's employment of both the alternative meanings of the word 'some', as 'some at least' and 'some at most'. There seems good reason for suspecting that the acceptance of the latter interpretation would again open the door [how is this possible?] to extralogical considerations." I again examined the work: and again without success. I then remembered that Mr Spalding himself had sent me this review, as written by a friend of his own: and I suppose his friend had mixed up reminiscences of conversation with those of the printed pages. I conclude that Mr Spalding did object to the doubly partitive system, but showed his objection only by suppression.

² Hamilton's editors have judiciously ignored the whole controversy. But on one point they have made an indirect reference, seemingly intended to intimate that any one who lays down 'all' as the symbol of universal quantity, does *in fact* lay down 'any' as its substitute in negatives. They say—"The comma (,) denotes *some*; the colon (:) *all*"; which is all that is given in explanation of the symbols of quantity. They then say—"Thus;— C:—, A is read *all C is some A*. C: +: D is read, *No C is any D*." (IX. ii. 277, 278.) The word *thus* implies exemplification. To read 'No C is any D' may be permitted: but he who *thuses* this reading of 'C: +: D' upon "the colon denotes *all*" reminds me of my old French master, an unhorsed hussar of 1815, who gravely taught that "All the French words are derived from the Latin: *thus* 'Seigneur', which is 'Lord,' comes from the Latin 'Dominus'."

'some at least' was 'possibly *none*', it presented itself as on the cards that 'some at most' might be 'possibly *all*', and the system in some unfathomable way Aristotelian.

It must be noted that a person might take "some at most" to be *singly* partitive, by supposing that the limitation "at most" refers to what are spoken of: thus "some at most are..." might be read as "we speak of some at most, be the rest what they may; of these we say they are..." But Hamilton takes pains to explain his meaning. His 'some' is laid down as both affirmative and negative; his 'some are' is declared inconsistent with 'all are', and his 'some are not' with 'none are', &c. [I have insisted on this, being in doubt whether it might not be denied: but I believe it is admitted. There is, however, a mode of speaking which may lead to error. It is said that Hamilton gives two systems, the "some at least" of the older logicians, and his own "some at most": and the headings of his own table (VI. 637*) adopt this distinction. But it must be remembered that the 'some' of the table is always 'not-none'; so that his new system is that of 'some at least *and* at most.' In no other way could IFI, or 'Some—is some—' be a combination of my ()) ((, as (VI. 632* diagram *d*) it certainly is. *December, 1862.*]

I now come to the consideration of the genuine Aristotelian system: I mean the system which was sketched out by Aristotle and held its ground down to the end of the seventeenth century. When (1847) I began this long discussion I knew Aristotle only, or almost entirely, as a collection of books of reference. Now and then it became necessary to decide for myself which of two contradicting statements about an opinion of his was true: so soon as one or both were rejected, my business with the *Organon* was settled for the time. In all cases of agreement I took it for granted that the leader was correctly followed. This assumption lasted until I was shaken by the translation of *ἀριθμὸς καὶ λόγος* into number and *speech*¹ which I exposed in my second paper. Being thus led to suspect that the mathematician Aristotle had been but loosely read, and shamelessly interpolated, by unmathematical followers, I paid more attention to his text. I took for my principle of interpretation that he meant what he said: and truly he is a writer who deserves this compliment. And I found that, though the great bulk of his ancient followers are faithful translators, our modern logicians, though nominally his adherents, have drifted into a system of quantification of their own, and have towed his name after them.

When I discussed Hamilton's system in my second paper, imagining it to be non-partitive in quantity, after pointing out that two of its propositions were without contradiction in the system, I noticed that very slight change would produce perfect logical consistency. This change was nothing but the substitution of *any* for *all*, in affirmatives as well as negatives. I proposed, though this is not absolutely required, that the implicit singularity should become explicit, as in 'any one' and 'some one.' This gives to six of the eight

¹ Plato, in the *Phædrus*, says that *Τοῦτου δὲ τὸν Θεῶν πρῶτον ἀριθμὸν τε καὶ λογισμὸν εὗρεῖν*: but whether Thoth is held to have invented speech I cannot say. Conic sections are for mathematicians only, or it might have been that Apollonius would have passed for the first inventor of curtailment and exaggeration. Smiglecius (*Disp.* 9, qu. 6) remarks that Aristotle does not count speech as quantity in the fifth book of the

Metaphysics: he will not allow it to be a quantity; and he says that Aristotle made it quantity in the *Categories* only as 'vulgarem ea de re opinionem secutus.' But when or how the world at large joined number and speech as cognate quantities he does not state: nor how a writer must be held to have concealed his own opinion from deference in an example freely chosen by himself, where another would have done as well.

propositions, the meaning which they have in the common system; and makes them, as usual, three pairs of contradictories. The remaining pair 'any one X is any one Y' and 'some one X is not some one Y', are also contradictory: the first giving X and Y as singular and identical. This system I called *exemplar*: its form is that of enunciation by selected example, the unlimited right of selection being expressed by *any*, the possibly limited right by *some*. This mode of expression stands opposed to the *cumular* form in common use: 'All X is some Y' being the cumular of 'Any one X is some one Y'; the aggregate of all its cases. Hamilton's criticism on all this can be seen in V. and VI. At this moment I am concerned with only one sentence of it (V.): he is persuaded, he says, (VI. 627*), that my "'Table of Exemplars' stands alone...in the history of science": he also (VI. 648*) calls it a "still-born monstrosity." I dispute his judgment in all that relates to quantification; I do not dispute his learning: I therefore quote these words as a strong testimony to my originality; and I highly value its definite character. But it only applies to half of the system: the remaining half does not stand alone in history as part of my paper. I assert that *the system of Aristotle and his followers consists of four EXEMPLAR propositions, with unquantified predicates*. I therefore maintain that the exemplar system which I gave in 1850, as a reduction to logical consistency of Hamilton's system, is a true¹ extension and step towards completion of the old system.

This assertion is mere statement of a fact, and a very simple one. Do the old logicians use the singular, or do they use the plural? Do they say 'Every, each, any,—man', or do they say 'All men'? Do they say 'Some man', or 'Some men'? If the first, they are *exemplar*, they speak by selection of example: for Every, Each, Any (with singular noun), are Every one, Each one, Any one; and Some, with a singular noun, is Some one.

The modern logician says 'All man': he speaks of the extent of the *genus* 'man' as divisible into *species*: he means that the collection of individuals 'All men'—all that exist, or all that can be imagined to exist, according to the universe he is in for the time—is divisible into smaller collections. My assertion is that 'All man is animal', thus understood; is a glaringly wrong translation of the '*Omnis homo est animal*' used by his foregoers, and of the *πᾶς ἄνθρωπος ζῷον* of the leader. Our English word *all*, when singular, refers only to some whole divisible into parts: and '*all man is animal*', before the phrase undergoes logical technicalization, is false, for it means that man is animal in legs and arms, body and *soul*. But the Latin *omnis* means *each, every, any one*, as in *sine omni periculo, omnis parturit arbor*. The whole divisible into parts is *totus, totus ager, tota mens, totus in illis*. And *totus* may naturally² replace *omnis*, and does: while *omnis* does sometimes replace *totus*. Thus we have *omnis insula* for the whole island, *omnis sanguis* for the whole blood. But *omnis* in the singular may collect the *individual* from its parts, never the *class*; when it is *all*, it is all the individual, not the collected species. In Greek *πᾶς* is both *ὅλος* and *ἕκαστος*: but *πᾶς ἄνθρωπος* is *each* or *every* man, not the *whole* man. Should a point be raised upon any

¹ Of this, as my second paper will show, I had not the least idea when I first gave it: in my mind the exemplar system was a derivation, by correction, from that of Hamilton, which certainly suggested it.

² In French the transposition is permanent, as in *tout*: the language derives no word from *omnis*. In Italian, *tutto* and *ogni* (singular) still translate *totus* and *omnis*.

ambiguity, and advanced in opposition to the preceding, I suppose it will be conceded that the particular quantity, if free from the same ambiguity, will settle the matter.

A logician strong in ancient association naturally tends towards the Latin singular: modern habits tend towards consolidation of plurality of individuals into *pieces of extent*. Hamilton compromises as follows (VI. 636*). He wants to translate "Some dogs do not bark" in fully quantified form. He does not say *Quidam canes sunt nulla latrantia*: this would offend the logical ear. Neither does he say *Quidam canis est nullum latrans*: this would be purely exemplar. He does say *Quoddam caninum est nullum latrans*: he speaks singularly of *an indefinite section of dog-nature*, and so conciliates the ancient exemplarity of phrase and the modern cumularity of thought.

I take, beginning with Aristotle, a score or more of logicians of all ages, and of every kind of note: I choose them merely because I happen to have access to them at the time of writing. I go direct to the places in which the technical propositional forms are laid down, and to the chapters on conversion. Some writers vary their phrases a little as they get deep into their subjects: but we know that they would all desire that their systems should be described by what they lay down in their fundamental explanations. Hamilton (VI. 626*) has collected a large number of quantifying words both in Greek and Latin; and might have got more: but it would have been difficult to have found any *early* writer who heaped his defining chapters with all this variety, or with any noteworthy amount of it.

Aristotle (*Analyt. Pr.* cap. 1, &c.) defines the *universal* as that which belongs to *every-one* or to *no-one*, τὸ παντὶ ἢ μηδενί: the *particular* as that which belongs to *some-one*, or not to *some-one*, or not to *every-one*, τὸ τινὶ ἢ μὴ τινὶ ἢ μὴ παντὶ. Instead of a long quotation from cap. 2, on conversion, I pick out *all* the quantitatives as they stand: they are μηδεμία, οὐδέν, πᾶσα, τι, τις, τι, τινί, τινί, μηδενί, οὐδενί, τινί, μηδενί, τι, παντὶ, τινί, μηδενί, οὐδενί, παντὶ, τινί, τινί, μηδενί, οὐδενί, τινί, τινί, παντὶ, παντὶ: not a plural among them. If all this be not exemplar, it must be because Aristotle said *one* and meant *many*. But so (by inference) does every person who says 'Any one man is some one animal' he means to speak of *all* men, and he does it. So that in what sense soever Aristotle is not exemplar, the exemplar system itself is not exemplar. Some will say that Aristotle only distributes: then the exemplar system distributes; and that in modern use does not.

Again, a person using cumular language would say that a universal negative is upset not only by predication of *all*, but of *some*: he would never say that 'none are' is contradicted by 'all are' and also by 'some one is'; he would certainly find intermediate room for the indefinite plural *some*. Now Aristotle (*Anal. Pr.* cap. 26) says that the universal negative is destroyed if the predicate be affirmable of πᾶς or some *one*, εἰ παντὶ καὶ εἰ τινί: this must be *every-one* or *some one*. He had previously said that the universal affirmative is upset if the predicate can be said to belong to no *one* or not to some *one*; καὶ γὰρ ἢν μηδενί καὶ ἢν τινί μὴ ὑπάρχει, ἀνήρηται [τὸ καθόλου κατηγορικόν].

Hamilton, in various¹ places, appends to the word *all* the parenthesis "[or every]", thus

¹ In one place (IX. ii. 303) there is a boldness of assertion which may be quoted as showing that genuine feeling of the sameness of *all* and *every* which, but for repeated illustration, my readers would hardly believe to have existed. Alexander

making it appear that in his mind "all man is all animal" and "Every man is every animal" are precisely the same English, and require precisely the same comment. In one place (IX. ii. 300) he translates Aristotle thus:—"For *all* or *every* [πᾶς] does not indicate...". Here, as elsewhere, he distinctly proclaims that he sees no difference between our English *all* and *every* in the two forms. But 'all man' has parts, which are species of the genus man: 'every man' has no parts, but makes assertions about the individuals of every species. I repeat that the modern logician has accustomed himself to the identification of two distinct things: he sees distribution in the cumular, and cumulation in the distributive, until the two readings are no longer distinct in his mind. He would speak of a country in which there are no single adults of either sex, as one in which all the Jacks are married to all the Joans: and, though not without ambiguity, he would be understood by mathematicians and other unlogical persons after a moment's thought. But he would also crave permission to say that every Jack is married to every Joan; which, to all but those whose English has been spoiled by modern logical technology, would enunciate the maximum of polygamy.

The expositors and translators, from Boethius to Thomas Taylor, B. St Hilaire, and O. F. Owen, give correct literal translation. I find exemplar language, to the exclusion of cumular, in Paulus Venetus, the Cologne regents, Isenach, Pacius, Burgersdicius, Keckermann, Crackanthorpe, Sanderson, Aldrich, &c. On the other hand, Molinæus, Wallis, Wendelinus, and the Port-Royal, out of about forty systems which I have examined, give more or less into plural forms. That most rigid¹ disciplinarian, Crackanthorpe, collected quantitative terms in profusion, and would have admitted a plural or two if such a thing had been canonical. His universal signs are *omnis, quilibet, quicumque, quandocumque, nullus, nemo, nunquam*: his particulars are *aliquis, alius, unicus, alter, nonnullus*. One of his *singular* terms is *omnis quando collective sumitur non distributive*: that is to say, the cumular is with him referred to the non-distributive² singular. He describes particular quantity as '*individuum incertum et vagum*.'

But the strongest testimony to the preponderance of exemplar expression is indirectly given by Hamilton himself, who says (IX. ii. 296) that the objection to "all man is all risible" because each man would then be all the class risible, "is only respectable by authority, through the great, the all but unexclusive, number of its allegers". Now the original is

Aphrodisiensis is quoted as saying that it is "impossible that all man should be all animal, as that all man should be all risible." Restoring *every* for *all*, the Greek will be seen to mean that whether the terms A and B be coextensive or no, 'Every A is every B' is impossible; for that, without any question about the *matter* of the terms, each individual would be many individuals. Hamilton, with his eyes quite shut to this point, will have him speak of material impossibility, which is clear in the assertion that 'all man is all animal.' But seeing that there is no material impossibility in 'All man is all risible'—which was believed to be true—he mends the text, and will have Alexander to declare this proposition only *useless*. Hamilton's quotation accordingly runs thus:—"For it is impossible that all man should be all animal, as [useless to say, (ἀχρηστων εἶναι must have dropt out)] that all man is all risible." Boethius (ix. ii. 308; *Patrolog.* lxiv. col. 323) has

certainly interpreted Aristotle in Hamilton's sense. If (ix. ii. 301—315) *omnis* be translated by *every* throughout, it will be seen that the *Greek* commentators take Aristotle in the sense I contend for, and that there is diversity among the others.

¹ Hamilton generally calls him 'Oxford Crackanthorpe'. He was for some five years fellow of a college, but his University sympathies could not have been marked: 'Puritan Crackanthorpe' would have been a better name; Anthony Wood would have protested against the other epithet. His book on Logic, written probably about 1600, was first published in 1622.

² This sentence, the quotation from Pacius presently given, and other things, lead me to suspect that my word *exemplar* is a synonyme of the word *distributive*, in its old sense.

“*omnis homo est omne risibile*”: that is, the logicians are, almost to a man, exemplar. Let who will believe that they nearly all refused a form tantamount to ‘the class A is the class B’, because they thought that each individual in A would thereby be pronounced to be all the class B. They meant the proposition in the sense of its correct translation, ‘Every man is every risible’, at which they laughed because, in Latin, as in English, the form implies that every separate man is every risible animal.

I cannot here properly give the volume of proof which it is easy to collect of the old mode of enunciation being what I call exemplar. What I have given will be sufficient for unbiassed minds, so soon as it shall appear that no equal force of citation is to be produced on the other side. I affirm then that the exemplar table which I gave in 1850 is the Aristotelian system, fully quantified, and made as complete in its forms as it can be so long as privative terms are excluded. But it must be remarked,—

First, that the system is not originally derived from distributions of quantification and search after their meanings. The leading idea is that of assertion or denial of class being contained in class, and of class being excluded from class. Indications of this origin are not wanting. Particular negation is very frequently enunciated by *οὐ πᾶς ἔστί*, that is, by denial of total inclusion or agreement: the greatest interest in ‘some are not’ is seen in ‘not every one is.’ If *quantification* had been a leading idea in the mind of Aristotle, *he* would not have been unable to use the pepper-box: but to him¹ the signs of quantity were, but incidents of expression.

Secondly, when a term was a genus, the *exempla* were species taken individually, not ultimate individuals. Thus when the quantified term was *omne animal*, the *hic, iste, ille, &c.* of the distribution would be *homo, bos, asinus, &c.*: when *omnis homo*, if *homo* were *infima species*, the details would be *Plato, Socrates, &c.*

Hamilton disputes the rational existence of ‘Any one X is any one Y’, and affirms (VI. 628*) that ‘*any*’ and ‘*any one*’ necessarily imply that there are *more*. This is not true: we have but a strong presumption of more. My critic had arrived at a conviction that *some* ought to be doubly partitive: but this was his own exclusive possession. The examination of his argument will show that *any* has no difficulty about it except what applies equally to *all*. When it is clearly understood that *part* is that which may be the *whole*—that is, when partition is formally excluded—it will then be seen that if there be that which is *any* part of Y, there can be but one part of Y, the smallest part is the whole, the whole is an individual. *Any* does not necessarily imply more than one: speaking of existence at this moment, any Queen of England is any Queen of Scotland: every Queen of England that can be found is all the Queens of Scotland there are; it would be treason to deny it.

The following addition to my statement as to quantification appears to me so evidently the true reading of the ancients, that I see no means of proving it to any one who, having

¹ My belief is that, in the mind of Aristotle, the four forms were merely intended to signify, in common language, the affirmation and denial of total inclusion, and the affirmation and denial of total exclusion. The entrance of quantifying adjectives or pronouns was only a non-essential incident of common language. Hence the old notion, so long

retained, that the *proposition* was universal or particular, not the *subject*. The departure from principle, which gradually clouded the theory, was the expression of denial of totality by a destructive example: as denial of ‘X wholly in Y’ by ‘certain X not in Y’. But there is a vestige of creation in *οὐ πᾶς ἔστί*, as mentioned in the text.

examined Aristotle, &c., entertains any doubt about it. Predication, the assertion made in an affirmative proposition, is not identification, far less equation, of subject and predicate, but simply declares the predicate notion to be true of the subject. This predicate has an adjective force, is rather an *attribute* of the subject—a frequent name in later times—than another and containing *superject*, and the proposition is very close to the character which in my third paper I have called *physical*. The predicate is applied *in its totality* to the individual of the subject class; and is distributed over as many individuals as the proposition speaks of, one by one, being given *whole* to each one of them. Thus ‘Every man is mortal’ says of each man *all* that it says of every other. No such image ever presented itself to the ancients as a notion which, instead of being applied whole, is itself cut piecemeal and assigned, bit by bit, to the bits of the subject. Such imagination is possible, because it is actual. We have before us (VI. 643*) the assertion that our attribute of mortality is divisible: that when we sum up men, we also sum up their *mortalities*: that Newton has this mortality, Leibnitz that, &c. But none of this is in the old notion of predication; and my present controversy is with those who arraign Aristotle and his followers at the bar of this principle, and declare that a plea to the jurisdiction must be overruled.

The Hamiltonians, and many others, read their great exemplar—as I may call Aristotle—in cumular sense, until they have lost¹ the perception of *τις*, *omnis*, *quidam*, being individuals: so that when a table of forms is presented in which singularity is enforced by the word *one*, enormous learning declares that it stands alone in history. A plain statement will show that the declarant read history through coloured glass.

Aristotle (*De Interpr.* cap. vii.) denies quantity to a predicate: he says that *no* affirmative could then be true—*οὐδέμεια γὰρ κατάφασις ἀληθὴς ἔσται*. And he² instances *πᾶς ἄνθρωπος πᾶν ζῶον*. Wholly exemplar in his enunciation, quite ignorant that *πᾶς ἄνθρωπος* meant *all man*,—the whole *extent* of the term *man*,—he said a plain Greek thing in a plain Greek way to Greeks who knew Greek. He said it is false—formally false, apart from the matter—that every man is *every* living being, meaning that then Socrates would be every living being, so would Plato, &c. When he affirmed a certain *quantification* to be *always* false, he meant false *in quantity*. And he was perfectly right: for there never was man who was more than *one* living being. The proposition ‘Every X is every Y’ makes singular terms both of X and Y.

¹ There is much interesting discussion in Mr Spalding’s *Introduction to Logical Science* (1857), but one single sentence curiously instances the want of power to see the singular which marks the modern logical mind. It will clearly appear that Mr Spalding was a man of extensive reading and acute perception. He says (p. 63), that the logical *some* is always indeterminate, some or other, not certain definite objects: “it is always *aliqui*, never *quidam*.” This is perfectly true; even the collector Crackanhorpe does not admit *quidam*. But it should have been “it is always *aliquis*, never *quidam*,” *quidam* being singular.

The only remark on the subject which I know of, published since Hamilton’s denial of the existence of the exemplar form,

is in the third edition (p. 57) of Mr Mansel’s edition of Aldrich (1856). Here *οὐ πᾶς*, when a substantive is put on, is translated *not all men*: another instance of the obliteration of the distinction between *every man* and *all men*.

² I noted in a former paper that the ordinary practice of translating *ζῶον* into *animal* has led to the representation that Aristotle ranked the immortal gods under animals. I have since found that Francis Patricius, when collecting his proofs that Plato was more orthodox (in the Christian sense) than Aristotle, cites this supposed opinion as one of his proofs. I hope none of the Greek Fathers have been belied in the same way.

Now Hamilton, who could not read in any other than the cumular sense, and who was possessed of the quantified predicate not merely as that which could be, and ought to be, but as that which is and must be,—asserted (IX. ii. 263), positively for this occasion only, that his great leader¹ talked “nonsense.” He misconceived the nature of the falsehood imputed to a universal predicate: he thought that Aristotle’s objection to ‘every man is every living being’ arose out of horses and dogs, rats and mice, &c., not being men. He charges the founder of logic (*sic notus Ulysses?*) with rejecting a logical form on the ground of certain matter making it false. To the last he could not see that the Aristotelian proposition attributes the whole predicate to every example of the subject: to the last he fixes on Aristotle the ‘*all man is all animal*’, of the modern school, the erroneous translation of ‘*Omnis homo est omne animal*.’ And he totally omits to notice Aristotle’s assertion that *not one* proposition of the form ‘Every A is every B’ can be true: from which, on his plan of interpretation, he ought to have accused his master of denying the existence of co-extensive terms.

Mr Baynes’s work (III.) gives links which had long been dropped in the history of this discussion: and its author is a decisive instance of the manner in which Hamilton’s teaching made cumular quantity the only one known in the history of logic, and the only one which can result from scientific analysis. The ambiguity which misled Hamilton seems to have come into general discussion by the sixteenth century: for by that time, taking the common belief that only man can laugh, the disputants had completely substituted ‘*Omnis homo est omne risibile*’ for Aristotle’s instance, as placing the true issue in clearer light. They then asserted, in plain and rational terms, that every man is not *every* laugher, for each man is only *one*. Mr Baynes calls this “the inconceivably inconsequent ground that if *all man* is all risible, then necessarily *each man* is all risible.” Here *omnis homo* is translated *all man*, and made to mean *all men*. Mr Baynes proceeds thus “...to take a parallel example (one,

¹ “The whole doctrine of the non-quantification of the predicate is only another example of the passive sequacity of the logicians. They follow obediently in the footsteps of their great master.....He prohibits once and again the annexation of the universal predesignation to the predicate. For why, he says, such predesignation would render the proposition absurd; giving as his only example and proof of this, the judgment,—*All man is all animal*.....Yet this nonsense (be it spoken with all reverence of the Stagirite) has imposed the precept on the systems of Logic down to the present day” (IX. ii. 263). Again (IX. ii. 296), Hamilton declares that “a general rule or postulate of logic is,—That in the same logical unity (proposition or syllogism), the same term or quantification should not be changed in import.” Hence he infers that if in “All man is all risible” the first all be distributive, so is the second. Hamilton may lay down this postulate for himself and those who like it: but there never was such a postulate in logic. On the contrary, the universal practice, down to our own time, implies that in ‘Every man is —’, *all* that follows the word *is* is predicated of *each man*. If we say ‘some men are twenty men’ the obvious falsehood drives us to metaphor: some men have *each* the power of twenty. But Hamilton would have it that it *has been* postulated that this proposition means a literal truth; *i.e.* this man is one, that man another, &c.—a certain

some making up twenty. It may be so understood by postulation: but it never has been.

But though the charge against Aristotle is a mere misconception of his meaning, Hamilton fell into the very error of which he accused his leader, namely, that of rejecting a *form* because certain *matter* falsifies it. He is speaking (VI. 627^a) of the use of *any* in affirmatives. “Now, let us try ‘*any*’ as an affirmative:—‘Any triangle is any trilateral.’ This is simple nonsense: for we should thus confound every triangle with every other, pronouncing them all to be identical. Nor, in fact, does Mr De Morgan attempt this. He wisely omits the form. But what an omission!” I pass over the last assertion with the observation that the very first proposition in the table here criticised is “Any one X is any one Y”: these words are followed by “*giving* there is but one X and one Y, and X is Y.” What I have here to do with is Hamilton’s distinct rejection of the form because it is false as applied to plural notions. It is false that “any triangle is any trilateral”: he who makes this assertion “confounds every triangle with every other”; that is, asserts the existence of only one triangle. And it is false that “every animal is a man”: but this does not compel the rejection of “Every X is Y” from the forms of enunciation, on the ground of the instance declaring horses and dogs to be men.

however, which they do not take) that if *twelve inches* are one foot, then necessarily *each individual inch* is also one foot." The example is clearly not a parallel, but it well illustrates the divergence. The parallelism of the *twelve inches* and the *all man* is so perfect, that they make the same angle—to a tenth of a second—with *omnis homo*. The reader who consults the whole of the rare and interesting matter which Mr Baynes¹ has produced will see much force in the following argument:—If the ancients had cumular meaning, and wrote as they did, they took inconceivably inconsequent grounds, and ought to have discovered that an inch is a foot. But it is very unlikely that so large a collection of acute thinkers should make puerile mistakes, and fail to see that a foot no longer than an inch follows from their principles, if it really did so. Therefore it is very unlikely that the ancients, writing as they did, had cumular meaning.

This preliminary argument could not be weighed in time still recent, because the possibility of anything except the *extended* term was not in thought. Some readers will perhaps never have seen, until they meet with it here, the assertion that when Aristotle and his long train of followers shaped enunciation in the singular number, it was because they were thinking as they spoke. Those readers may have learnt to see nothing but cumular in the exemplar form, nothing but plural in the singular; and they may attribute this lapse of vision to Aristotle. If so, I remind them that the singular and plural could hardly have been so easily confounded in a language which *had the dual interposed*. It is worth² a thought whether

¹ Mr Baynes is particularly worthy of citation on this subject because, quite fresh from the teaching of his distinguished guide, he threw himself into the history of quantification, and made very valuable researches. It is curious to see how he speaks of cumular quantification, as both a logical and a vernacular necessity. Speaking of the exemplar grounds of objection to "Every man is every risible," which to him could be nothing but "all man is all risible," he says (p. 93), "When we consider these grounds, and remember the real ability of the men by whom they were successively urged, we cannot but be struck with a wonder amounting to marvel, that they could remain satisfied with them, and that a truth so obvious on its first enunciation, so imperative on its fuller exposition, should have been so uniformly and so long thus rejected." Nevertheless, the clear exposition of Pacius, so deservedly high among the expositors of Aristotle, would have stopped the wonder of any one who knew the exemplar sense: though somewhat long, I repeat it from Mr Baynes, "Hunc errorem ut Aristoteles tollat, ostendit universalem notam nunquam posse adjungi attributo; quia tunc omnis affirmatio falsa esset. Quod declarat exemplo hujus enunciationis 'omnis homo est omne animal,' quæ sine dubio falsa est: nam si homo esset omne animal, esset etiam asinus et bos. Sed notare hic oportet, alia attributa latius patere quam subjecta, alia vero reciprocari cum subjectis.....Ubi igitur attributum latius patet, ut in exemplo Aristotelis, res dubitatione caret: certum enim est, affirmationem esse falsam, nec posse dici, 'omnem hominem esse omne animal'. Sed merito dubitatur de attributis, quæ recipiuntur cum subjectis, veluti si quis dicat, 'omne animal est omne sensu præditum', et 'omnis homo est omne aptum ad ridendum': nam hic absurditas illa non æquè apparet, ut in illa enunciatione, 'omnis homo est omne animal'. Sed ut intelli-

gatur has quoque enunciationes esse falsas, in quibus attributum, quod recipiatur, adnexam habet particulam *omnis*, notare oportet, hanc particulam *omnis*, habere vim quam in scholis vocant distributivam; ut *omnis homo*, proinde valeat atque quilibet homo, vel *singuli homines*; et similiter omne animal, idem valet, quod singula animalia, vel unumquodque animal seu quodlibet animal. Quapropter si verè diceretur, 'omne animal est omne sensu præditum' etiam homo esset omne sensu præditum; nam qui dixit omne animal, non exclusit omnem hominem, homo igitur esset quodlibet sensu præditum: proinde hac ratione fieret, ut homo esset equus, et bos, quandoquidem equus et bos sunt sensu prædita." (Pacius in *Aristot. de Interpret. cap. VII.*) The reader will see how clearly Pacius has laid down the difference between exemplar and cumular, and how distinctly he has stated that the exemplar, not the cumular, is the ancient reading.

Should a teacher be so accustomed to read exemplar enunciation in cumular sense that the first time an exemplar table is explicitly presented he declares it to stand alone in the history of science, that teacher and his pupils may well regard the above with "a wonder amounting to marvel". The issue is a simple one. Aristotle, Pacius, &c. say—We enunciate in the exemplar form of thought: the moderns reply—You do no such thing; or if you do, we have lost the power of seeing the distinction, whence there is no difference.

² Were it only because it has hardly been thought of. In English the confusion of singular and plural has occurred. The proverb says, "One's none; two's some". That one should be none (*ne one, not one*) defies etymology: but as *not one*, and *only one*, both deny some with its ordinary plural implication, and *some* and *none* pass for alternatives in life as well as in logic, the way in which the confusion arises is seen.

the possible ambiguity arising out of the dual and plural did or did not dictate adherence to the singular: the plural must have frequently taken in the dual, frequently not: that is, the plural must have frequently meant two or more, frequently more than two. If this be the *explanation*, it does not alter the *fact*. And to the fact must be joined the utter extinction of the exemplar form in the minds of modern logicians: an extinction so thorough that such a chart of logical history as Hamilton's mind had not that course laid down, even as a possibility. It was easier to him to imagine Aristotle talking such "nonsense" as that a form must be rejected because it was not true of all matter, than meaning his *singular* number to speak of *one*: and a table of exemplar forms published in 1850, appeared to him to stand alone in history.

The exemplar form of statement is that both of geometry and of algebra. A proposition in Euclid assumes *some one* case of satisfaction of hypothesis, and the demonstration lies in the perception of the receiving mind that nothing in the reasoning is adverse to the implied assertion that this *some one* may be *any one*. But this form of exact science is more pointedly exemplar in phraseology than the system of Aristotle: its distributor is *quilibet*, not *omnis*. We have an exemplar ladder in English: its steps are *any one*, *each one*, *every one* (*quilibet*, *unusquisque*, *omnis*). The third is certainly not *all*; for it is but *one*: but it is more truly the grammatical singular of *all* than either of the others, near as they are. It would be difficult to describe the differences of meaning: that there are differences will appear by our being able to make sentences in which all three shall occur, without power of transposition. For example:—"If you feel able to cope with *any one*, try *each one*, and so you will master *every one*"—the order cannot here be altered. The first, *any one*, has a purer unitarian character than the others: the second and third are more nearly transposable. Without further inquiry, *any one* is the most proper for strict exemplar use, as being applicable in negative predicates.

The form 'any one X is any one Y' is much wanted in geometry. In my last paper I pointed out that many indirect demonstrations are only refusals of the knowledge of contraposition; others, far less excusable, arise from refusal of the right to convert 'any one X is any one Y.' When X and Y are of the same number of instances, the propositions 'Every X is Y' and 'Every Y is X' are equivalent: which is most evident, if there be any gradations of evidence, when X and Y are singular. Consequently, if there be but one X and one Y, and if the X be the Y, it need not be proved that the Y is the X. Suppose that a person, holding himself to have shown that Junius was an individual, and knowing that Philip Francis was an individual, and that Francis was Junius, were to proceed as follows to prove that Junius was Francis:—If not, let Junius be X, another than Francis: then because Francis is Junius, and Junius is X, it follows that Francis is X; that is, Francis is another than Francis, which is absurd. So it is, and so are you too, would be the answer of common sense to the proposer of such a proof: is the principle of difference so much clearer than that of identity, that any one has a right to suppose the sameness of 'X is Y' and 'Y is X' to want corroboration by help of X being no other than itself? But this is done in geometry. Not to insist on antiquity, let us take Legendre, a professed amender of Euclid: he knows that through a point can be drawn but one perpendicular to a plane, and one parallel to a line; yet

(Book V. Prop. 7) having proved that *the* parallel to a certain line is *the* perpendicular, he gives further proof, of the kind¹ above, that the perpendicular is the parallel. And this is supposed to be the climax of rigour; proof *by syllogism* that if the sole A be the sole B, the sole B is the sole A. But where would syllogism have been, if this had not been true?

It must not be forgotten, in defence of Euclid, and of geometry without logic, that the above procedure may give *evidence*. When thought has not been analysed, and those who teach are determined that it shall not be analysed, Euclid presents the perfection of the way of doing without. But the time must come when his rich mass of raw thought shall be the material of exercise for logical analysis; when it shall be employed to place the forms of thought in their due order of sequence; when it shall be the ground on which it shall be learnt that the conversion of identity by help of syllogism is reasoning in a circle.

I shall proceed to connect the exemplar form with others: but there are several points which it will first be desirable to notice.

By a *restrictive* proposition I mean one which, of its own nature, imposes some absolute condition, positive or negative, upon the quantity of one or both of its terms, or of one or both of the contraries of its terms. I say *absolute* condition: not *relative*, as in 'All X is Y', which demands that the Ys shall at least equal the Xs in number. The only such propositions yet met with are 'Some X is not some Y', which requires that, when identical, X and Y are not singular: and 'Any X is any Y' which imposes on X and Y both singularity and identity. But besides *singular identity*, we shall find ourselves, so soon as we begin to carry every mode of enunciation into every case, obliged to recognise *penultimate identity*, in which the contraries of our two terms are singular and identical; also *singular and penultimate identity*, in which both² our terms and their contraries are singular and identical; and *singular and penultimate contrariety*, in which two singular terms are each identical with the contrary of the other. The laws of thought will produce these forms³ by the score, as we shall see.

¹ We may laugh at the geometer establishing by syllogism the conversion of identity, but such is the force of habit that the logician may be a geometer without carrying away into logic the illustrations which lie nearest the surface. My opponent, Mr Mansel—out of formal logic—is a mathematician, and applies psychological thought to first principles. In formal logic he argues in favour of "All A is all B" being a simple proposition, in opposition (iv. 116) to my assertion that it is complex; and Hamilton quotes his argument with approbation. Mr Mansel says "I cannot assert 'all A is B and all B is A' without having thought of A and B as coextensive, i.e. without having made the judgment 'all A is all B'." Euclid (i. 5), the universe being *triangle*, proves that "all isosceles is isogonal", and then (i. 6), proves that "all isogonal is isosceles"; and then, and not till then, does his reader become aware that "all isosceles is all isogonal." Both the components are in thought before the compound. Geometry is the richest field of coextensive notions: it swarms with instances of coextension gained by synthesis of counter-inclusions. I admit that a compound cannot be decomposed except by those who have got it to decompose: but, on the other hand, those who have hold of

the components may put them together. In the dining-room pudding may be treated as compound of flour and plums: but if before that, in the kitchen, flour and plums had not been treated as components of pudding, the dining-room process would have been Barmecide theory.

² I am duly sensible of the figure which a universe of two instances will cut: but I may say on my own behalf, that though I shook it out of the pepperbox, I did not put it in. The laws of thought, which did put it in, are solely responsible for this contempt of established authority. Nor can I even claim the invention of the mode of shaking which brought it out. Hamilton had used the method, and produced, if not singular identity, at least its denial: this was the first of the class of restrictives. I think that here, as elsewhere, it will be found that one instance is but ill understood until more arrive.

³ By introducing "some X is not some Y", the denial of a restrictive, Hamilton, when non-partitively interpreted, has given a conclusion to two invalid forms (.()) and ((.)). It will presently be pointed out that every one of the thirty-two invalid forms gives a conclusion, the denial of a restrictive.

The time is coming when no one of two correlatives will be introduced without as full an introduction of the other. Logic abounds in pairs¹ of which both must enter thought together, but of which one only has been allowed to become prominent in language. Of *converse* relations, and of *contrary* (or *contradictory*) relations, we generally see one embodied, while the other is but as a shadow. *Part* and *whole* give a marked instance: our language is familiar with a whole of several parts, but hardly knows such a phrase as 'a part of several wholes'.

How loosely the subject of correlation is considered may be seen in the case of *assertion* and *denial*. In logical writings these are—I do not say defined, but—treated as alternatives. In the wide world it is generally assumed that all which a person cannot assert he can and will deny: let any one hesitate at affirming, and four out of five of his hearers will report him as having contradicted; and the four will be precisely those who see no use in logic. The books on logic so far favour this inaccuracy that they take no notice of any intermediate² between affirmation and negation. The following brief summary will show how easily a sufficient notation of syllogism will enable us to collect all cases of what I shall call *indecision*. I mean *inferential* indecision; in which inability to affirm or deny a conclusion is a necessary consequence of inability to affirm or deny a premise.

When two premises, A and B, give a conclusion C, it follows from the usual law of *opponent* reduction, as I call it, that the *assertion* of either premise, with hesitation at *denial* of the other, is equal hesitation at *denial* of the conclusion. For one premise, with denial of the conclusion, is denial of the other premise. Hence any hesitation at affirmation of the contrary of the other premise, is equal hesitation at affirmation of the contrary of the conclusion. That is to say, there are syllogisms in which assertion and non-denial give non-denial; there are others in which assertion and non-assertion give non-assertion: of four possible forms these are the most systematic; each form including the other three.

The syllogisms of undecided denial, in which assertion and non-denial give non-denial, are precisely those in which assertion and assertion give assertion. Thus $))) \cdot)$ gives $) \cdot)$; or $X)) Y \cdot) Z$ gives $X \cdot) Z$. Assert either $X)) Y$ or $Y \cdot) Z$, and refuse to deny the other, and we must refuse to deny $X \cdot) Z$. This gives rise to two forms of the other kind. Assert $X)) Y$, and refuse to affirm $Y ((Z$, or assert $Y \cdot) Z$, and refuse to affirm $X ((Y$; in either case we must refuse to affirm $X ((Z$.

¹ Many common words, when they represent material objects, have meaning of which relation to other objects is an essential part; whence arises some confusion. An *island* is land surrounded by water: is the surrounding water a part of the island? Yes, for no water, no island: no, for if you walk into the water, you quit the island. The ambiguity is easily explained in this case: there is the object named, and the relation by which it is named: the object does not extend into the water, but the droits of the notion do, perhaps as far as those of the crown. Again, what is a box? Is it a space bounded by an envelope of wood, or is it the envelope itself? Not the first, for we certainly move a box from town to town, which no one can do to a bit of space. And yet, when I asked a little girl what

would happen if the nails used in fixing a card of address were too long, she answered that they would "get into the box, and spoil the things." We get over these ambiguities in common life; but they are sore puzzles in philosophy.

² "But negation and affirmation must be contradictorily opposed; as Aristotle has expressed it,—'Between affirmation and negation there is no mean,'" (Hamilton, vi. 636*). True enough so far as this, that of affirmation and negation one must be true and the other false; but not true of enunciation. I may not know which is true and which is false; I may have the courage to avow it, and to follow Hamilton's principle of finding language for all that is in thought.

In syllogisms of undecided assertion, in which assertion and non-assertion give non-assertion, the law of validity is as follows. When one proposition only is particular, that particular must be the undecided assertion. Every form is valid in which a universal and a particular occur: but when both are universal, or both particular, the middle term must be *balanced*, that is, of the same quantity in both. The symbol of the conclusion is derived as in the ordinary syllogism, with this exception, that the spicula which we are to obtain from the decided proposition must be inverted. Thus, denoting want of power to assert by \checkmark affixed, we may shew that $))(\checkmark)$ gives (\checkmark) , $))(\checkmark)$ gives (\checkmark) , $(\checkmark)(($ gives (\checkmark) , $(\checkmark)(\checkmark)$ gives $((\checkmark,)(\checkmark)\checkmark)$ gives $\checkmark(\checkmark)$, &c. But $))(\checkmark)$ and $)\checkmark(\checkmark)$ give no conclusion.

For example:—"We can hardly undertake to say that all men are responsible for the effects of their actions, independently of motive: for there are men who are really incapable of any consecutive tracing of consequences, a thing we must hesitate to affirm of beings whose responsibility is for consequences". This form is $(\checkmark)(\checkmark)$, giving $)\checkmark)$; as follows:

- (\checkmark) Some men are not capable of tracing consequences.
 $)\checkmark)$ We will not affirm that there are beings responsible for consequences who are incapable of tracing consequences.
 $)\checkmark)$ Therefore we will not affirm that all men are responsible for consequences.

For *will not*, we may read¹ *must not, cannot, ought not, need not, &c.*, provided only that we make the conclusion follow the premise; all that is wanted is *non-affirmation*, be the restraining cause what it may. The forms of indecision are precisely those in which affirmation and denial give denial: but the mere presentation of indecision would have been a valuable addition to the logic of the middle ages. Here there was nothing but sharp assertion and denial: and theology, the science in which the word *dogmatism* got its evil sense, was made to look even more positive than she really was. Forbearance is not categorical; and the syllogism of charity is the syllogism of indecision.

The portion of all possible thought within which our concepts are and are² to be

¹ The terms of relation can be applied: and it will be good exercise to learn to see the combinations. If we call 'that which we cannot affirm to be a species' an *unaffirmed* species, we may read as follows. In $X))Y((\checkmark Z$, or $X((\checkmark Z$, we see that a species of an unaffirmed genus of Z is itself an unaffirmed genus of Z . In $)\checkmark)(($, giving $)\checkmark)$, we see that an unaffirmed species of a genus is an unaffirmed species. In $((\checkmark)\checkmark)$, giving $)\checkmark)$, we see that the genus of an unaffirmed deficient is itself an unaffirmed deficient. In $)\checkmark(\checkmark)$, giving $)\checkmark)$, we see that the unaffirmed coinadequate of an external is an unaffirmed deficient.

² Falling asleep while I was considering how to answer this objection—that a definite universe is material—in the most elementary form, I found Logicus, Mathematicus, and Neuter, in the middle of an argument upon the very point. L. In "All X is Y" we have a pure form of thought, divested of matter: we see *how* we think, independently of *what*. N. It's not true, though. M. He does not mean that whenever he *says* X he *says* Y. L. By no means: X and Y are names; and my proposition asserts that whatever I may name X, I may name Y. N. Why, so may I, or so may any man; but —

L. Nay! I meant with truth, according to received meanings: X and Y are representations of concepts, and the concept X is asserted as what ought never to be in thought without the concept Y. M. But concepts are *matter* of thought, are they not? L. Yes: but X and Y are but concepts as concepts, recognised as different concepts by difference of symbol, stated to be thought as included and including by the proposition. M. But if your form contain concepts as concepts, and if concept be matter, surely your form contains matter as matter. N. You wont get out of that, I see, let concept be which it will, Greek or Hebrew; it may be one or the other for me. L. You confirm me entirely in what I was going to say, that the goodness of formal inference may be perceived independently of the meaning of the terms; *concept* is to you as would be X or Y. M. Then my remark is admitted to be just? L. Certainly: matter as matter is present in every enunciation; but the perception of the formal force of a proposition is independent of the material *differenoes* between the *different matters* which it contains or might contain. M. That is to say, you treat *concept* as algebra treats *number*? L. Precisely: logic preceded algebra in the use of general terms. M. But algebra never

contained is the *universe*. When that universe is in any way divided into two parts, the name by which the individuals in one part are distinguished from those in the other is a *term*. All terms are names; but some names are not terms. When *animal* is the universe, *hairy* is a *term*, a divider of the universe: *mineral* is not a term, but a *vacuous* name; *sentient*, *sensu præditus*, is not a term, but an *omnitenent* name; *mineral* and *sentient* equally fail to divide the universe, the first by *non-continence*, the second by *non-exclusion*. These contraries, the vacuous and the omnitenent, must stand or fall together. When we speak of *terms* only, we see as clearly that contrary terms have no *term* which is a *common whole* as that they have *no common part*; for nothing less than the universe contains both: no *term* contains both. To what I have said (in former papers) on the exclusion of omnitenent¹ names, I add that, even in the prevailing system, the predicate of a negative must not be of universal extent, for then some of the subject would be shut out of the universe in which it is to be: and that if the predicate of an affirmative be a universal, the proposition asserts no more than is held to be asserted of the subject,—by its mere presence.

In order fairly to put the exemplar and cumular forms into connexion, it is necessary to examine them with the fullest introduction of both sides of every correlation which makes any appearance at all. Until lately I have never felt assured that they were not two different systems, presenting points of agreement. But before making the investigation, it may be shown that neither one system nor the other can claim to *dictate* the precise forms of enunciation. That claim is made by another system, more fundamental than either; and is made demonstratively.

The logicians have admitted only one idea of relation: the connexion between terms *as terms*: I call the system thus produced by the name of *onymatic*. They make what appears to me a confusion between the term and the objects of thought which it represents: they identify terms which are not identical as terms, whenever they can identify the objects represented. Now two terms, as terms, whatever may be the case in etymology, cannot have any relation to each other in logic except what they gain by their relations to things signified or excluded. And the only relation of a term to a thing is that of *applicable* or *not applicable*. And a term, as a term, has its contrary: a term² without a contrary is no term.

talks about a *pure form* of numbering from which *matter* of number is excluded. With us numbers lie hid in sealed packets, marked outside with letters: but they *are* numbers, whether before or after assignment or discovery of their *values*; differences of value exist or may exist, though ignored as to amount so long as only the consequences of difference as difference are in question. L. It is, I dare say, not quite correct to affirm that the form of the proposition is void of matter: we introduce different matters, leaving the differences unsymbolised, except as differences. But for this, the form should rather be "Every is " than "Every X is Y". M. Then what objection do you make, looking at the way in which man thinks his thought and says his say, to the introduction of a sphere or universe, say U, on the same terms as X or Y: as material as they are, as unspecified with reference to *this* or *that* as they are; allowing full right to consider, as one case, what I might perhaps denote by $U=\infty$? What Logicus answered I could not even dream; so I awoke.

¹ This universe is sometimes all that exists objectively, and sometimes all that can exist in thought. If there be any one who demands yet more, and wants room for that which cannot be in thought, whether as possible or impossible, he invades the universe of a higher power, and will perhaps square the circle; a problem which a speculator of the last century reduced to the following,—*Construere mundum divina menti analogum*.

² When Aristotle practically dismissed the privative term under the name of *aorist*, he had previously denied it to be the name of anything. My belief is that he was inclined to deny that it is a *term*; he thought that *not-man*, for instance, takes in so much, and shuts out so little, that it is hardly distinctive. If such were his idea, he would have refused, *à fortiori*, the title of *name* to a word which designates the whole universe, both *man* and *not-man*; which shuts out nothing whatever.

As to the *aorist* character, I should like to know, supposing a name to include just half the universe, which is the *aorist*,

The relations between terms, the only ones admissible because they *are* terms and for no other reason, are those of *applicable to some the same object*, and *not applicable to any the same object*. If X and Y be two terms, x and y their contraries, then, making full use of all our correlative alternatives,—namely X or x, Y or y, of joint application or not of joint application,—we shall obtain what must be all the forms of enunciation admissible into the system of relations between terms *as terms*. And from our purely onymatic enunciations we may decipher the common forms of identification, or of discrimination, in which the distinction of *term* and *designated object of thought* is afterwards lost to language¹ by the application of *is* and *is not* to the *terms*. The results are as follows:

Onymatic relation between terms.	Proposition.	Relation.	Symbol.
X, Y have joint application	Some Xs are Ys	X partient of Y	X () Y
X, Y have no joint application	No X is Y	X external of Y	X)-(Y
X, y have joint application	Some Xs are not Ys	X exient of Y	X (.(Y
X, y have no joint application	Every X is Y	X species of Y	X)) Y
x, y have joint application	Some things neither Xs nor Ys	X coinadequate of Y	X) (Y
x, y have no joint application	Everything either X or Y	X complement of Y	X (.) Y
x, Y have joint application	Some Ys are not Xs	X deficient of Y	X).) Y
x, Y have no joint application	Every Y is X	X genus of Y	X ((Y

The moment we begin to speak of *part* of a term, we are no longer using the term in the purest onymatic sense: we have made it stand for the collective group to each individual of which it applies as a designation. Before we introduce the word *part*, I observe that, as every relation has both its converse and its contrary, it is advisable in every case to examine both conversion and contradiction. One converse of ‘X, Y, have joint application’ is ‘there are objects to which both of the terms, X, Y, are applicable’. We have nothing to remark about *this* conversion except that it furnishes the most natural mode of reading the new propositions (.) and)(.

The above table exhausts, I think demonstratively, all purely onymatic relation; that is, all in which the terms are names to be applied or not applied, not names used *for objects* by conventional substitution. There is no notion of quantity in this system: the affirmatives—the assertions of joint application out of which the particulars spring—demand ‘one or more’ objects to which joint application is made. But this is only tantamount to ‘There exists that which...’ and its quantity is only the notion of *one* which precedes numeration in *Omne quod est, eo quod est, singulare est*. I have not space to

that name, or its privative? This is the most nicely balanced question in logic, just as the following, which even *Notes and Queries* cannot answer, is the most nicely balanced question in geography. If all the northern hemisphere were land, and all the southern hemisphere water, which should we have to say, that the northern hemisphere is an island, or the southern hemisphere a lake? I am Buridan’s ass in respect to both questions.

¹ This distinction is usually obliterated in all cases in which the term has *meaning*. But let abstraction be placed

before an unpractised mind without warning, and reason may, properly enough, refuse the identification of the *terms* by the substantive verb. A book on logic was presented to a young person of my acquaintance: after some time an account of progress was asked for. “Oh!” was the answer, “I read as far as ‘Every X is Y’, but I knew *that* wasn’t true, so I left off.” Assuredly ‘no X is Y’: every child who learns the alphabet is plagued with 650 such negations. But it may chance that every [thing signified by] X is [also one of the things signified by] Y.

develop the objections which the pure onymatic system, as well as other views, furnish against the Hamiltonian doctrine that all enunciation is equation of quantity: but even those who would not admit their force will guess what they are.

Let us now introduce the notion of multitude of objects which, considered as having a common designation, give the idea of *class*, part of the universe separated from the rest. Each class—except when singular—has sub-classes which are its parts, and—except when penultimate—is a sub-class of classes which are its *wholes*. Any collection of objects which is itself only part of the universe may be called a class, as capable of receiving a common designation which is also distinctive. We shall find the eight onymatic forms starting up in the following simple appearance, without the reality, of system: this I say because, as shall be shewn, we have only a systematic selection from a complete system. The remainder, after the selection is made, will contain *restrictive* propositions, or their denials. And this will happen in all attempts to systematize which involve quantity, and which make a full use of all correlatives which are admitted at all. Observe that we do not admit the universe as distinctively a *whole*, because it is a whole of all terms, and not itself a term.

Some class is part of both X and Y	X partient of Y	()
No class is part of both X and Y	X external of Y)·(
Some class is whole of both X and Y	X coinadequate of Y) (
No class is whole of both X and Y	X complement of Y	(·)
Some class is whole of X and part of Y	X species of Y))
No class is whole of X and part of Y	X exient of Y	(·(
Some class is part of X and whole of Y	X genus of Y	((
No class is part of X and whole of Y	X deficient of Y)·)

Here we see terms without their contraries; ‘*some*’ with one terminal extreme, ‘*none*’, but without the other, ‘*every*’; conjunctions, as ‘both part of X and part of Y’, without the corresponding disjunctions, as in ‘either part of X or part of Y’; conjunctions of affirmations only, without the corresponding cases of one affirmation and one negation, or of two negations. If the whole system were formed, every case which does not reproduce one of the above, would either require terms coextensive with the universe, or penultimate, or singular; or would deny propositions requiring such terms. But as this point will presently receive sufficient illustration, I shall proceed no further with it at present: I shall also presently have occasion to go some way into the extension.

Both the preceding systems of enunciation have an exemplar character: in both the forms we see ‘there does exist an instance of...’ denied by ‘there does not exist any instance of...’. I will now proceed to an exemplar system in which part or whole of one term is in affirmation identified with part or whole of the other; the unlimited selection *any*, and the possibly limited selection *some*, either or both, being used in all combinations. The restrictive propositions will be denoted as follows: singular identity by ($:=$); penultimate identity by (\equiv); singular and penultimate identity by ($:\equiv$); singular and penultimate contrariety ($\circ\circ$). And that singular identity in which one term and the contrary of the other are singular and identical, may be denoted by (\cdot —) or by (—·), as convenient.

<i>Part and Part.</i>	<i>Whole and Whole.</i>
Any part of X is any part of Y ::=	Any whole of X is any whole of Y ::=
Some part of X is not some part of Y ::= denied	Some whole of X is not some whole of Y ::= denied
Any part of X is some part of Y))	Any whole of X is some whole of Y ((
Some part of X is not any part of Y (.	Some whole of X is not any whole of Y).
Some part of X is any part of Y ((Some whole of X is any whole of Y))
Any part of X is not some part of Y).)	Any whole of X is not some whole of Y (.
Some part of X is some part of Y ()	Some whole of X is some whole of Y) (
Any part of X is not any part of Y).(Any whole of X is not any whole of Y (.)
Only (.))(excluded.	Only).(() excluded.
<i>Part and Whole.</i>	<i>Whole and Part.</i>
Any part of X is any whole of Y :::	Any whole of X is any part of Y :::
Some part of X is not some whole of Y ::: denied	Some whole of X is not some part of Y ::: denied
Any part of X is some whole of Y ::=	Any whole of X is some part of Y ::=
Some part of X is not any whole of Y ::= denied	Some whole of X is not any part of Y ::= denied
Some part of X is any whole of Y ::=	Some whole of X is any part of Y ::=
Any part of X is not some whole of Y ::= denied	Any whole of X is not some part of Y ::= denied
Some part of X is some whole of Y ((Some whole of X is some part of Y))
Any part of X is not any whole of Y).)	Any whole of X is not any part of Y (.)
Only (().) included.	Only)) (. (included.

The symmetry and compensation of this table is an instance of what we shall always find whenever correlatives are fairly and equally used. By carrying the whole through Xy , xy , and xY , as well as XY , we produce the main system eight times, and complete the system of restrictives. We may call the system of *part and part* and of *whole and whole* by the name of *balanced*¹; the others being *unbalanced*. The rules of distinction and identification of forms are as follows:—1. *Balanced readings exclude* from the general system nothing but *any affirmed of any* and *some denied of some*: *unbalanced readings admit* nothing but *some affirmed of some* and *any denied of any*. 2. When exclusion is not thereby made admission, or *vice versa*, ‘any part’ and ‘some whole’ are convertible, as also ‘any whole’ and ‘some part’. Thus ‘*Some part of X is some whole of Y*’ is the same proposition as ‘*Any whole of X is some whole of Y*’.

There are two positions which have, alone or together, been expressed or implied in several distinct quarters. First, that the mere completed distribution of the *quantifying words* is the completion of a true logical system, dictated by the laws of thought. Secondly, that the eight forms first obtained by complete distribution of *contrary terms* through the old forms is an arbitrary system, which might have been something else if the framer had so pleased. I contend that these descriptions should be exchanged: that the arbitrary character, but not to so great an extent as asserted of the other, belongs to Hamilton’s system before the correction which makes it simply the true extension of the real Aristotelian system; and that the

¹ These useful terms, suggested by Hamilton, may be used in reference to any pair of correlatives.

extended cumular system is not in any sense arbitrary. Take what plan we please, carry the correlations fairly out, and we arrive at the eight onymatic forms, together with restrictives and their denials. I shall take two more cases, observing that *restrictives* have appeared in every system except the original, in which nothing appears except *terms* as distinctive *names*, under the relation to objects of *applicable* or *not applicable*.

First, I take the exemplar form in which some or other extent, or any extent—*some class* or *any class*—is identified, conjunctively or disjunctively, with both whole or part of X and whole or part of Y. This is that portion of extension which I previously announced that I should give. I write down only the apparent affirmatives, leaving the reader to construct the negatives: for brevity, I also write ‘some X’ for ‘some one part of X’, and ‘any X’ for ‘any one part of X’. And first of conjunctive comparisons.

Any class is both any X and any Y	Universe of one individual. No terms
Some class is both any X and any Y	X and Y singular and identical
Any class is both any X and some Y	Universe of one individual. No terms
Some class is both any X and some Y	X species of Y.))
Any class is both some X and some Y	X and Y universal. No terms
Some class is both some X and some Y	X partient of Y. ()
Any class is both some X and any Y	Universe of one individual. No terms
Some class is both some X and any Y	X genus of Y. ((

Among these assertions and their denials we have the Aristotelian forms complete: and our assertions give the affirmatives, our denials the negatives. The disjunctive forms may now follow: *either* meaning *either or both*, the true¹ contrary of *neither*. For ‘*both*’ and ‘*and*’ substitute ‘*either*’ and ‘*or*’: none² but restrictives will be found. In going through all the varieties of application of *part* and *whole*, we come upon the *complement*, yet unseen, among the correlative affirmations of exclusion: as in ‘Any class is either not any whole of X or not any whole of Y’. But the view opens as we proceed. *Part* and *whole* are but synonymes of *species* and *genus*: at our present point we may ask what would result if we were to examine all the cases of ‘Any [or some] class is both — of X and — of Y’ when either blank may be filled up with any of the eight names of relation? I certainly should not have asked this question if the answer had required me to exhibit to the reader such a shaking of the pepperbox as would seem necessary. The truth is that I have all but answered the question in previous writings, as shall presently appear.

I positively assert that the first of the preceding views³ contains demonstration that the relations between terms, derived from their relations to objects, must be the eight forms, and no others. The postulates are that by a *term* we mean a *distinguishing* mark, the sign of some object or objects, not the sign of others; and that to any collection of objects which is not the whole universe, we have a right to assign a term. I contend, as in my last paper,

¹ “Shall I bring both?—No need, either will do.” Here the *either* is *either or both*.

² If *individual* were used instead of *class*, the restriction would be removed from some propositions. Thus “any class is either some X or some Y” enunciates a universe of two in-

dividuals, one X and one Y: but “any individual is either some X or some Y” means X (·) Y, without restriction.

³ The first idea of this mode of derivation is in my *Formal Logic* (p. 106): but I did not then see either the import or the importance of what was there given.

for the right and duty of logic to treat of other relations between terms, derived from the relations of objects to one another: but my present concern is with onymatic relations only. I proceed to a more systematic connexion of the eight forms than I have yet given.

Each universal is in two ways of a universal character, one of an *active* meaning, the other of a *passive*. Thus,

X)) Y	X wholly included in and wholly incomplete of Y
X ((Y	X wholly including and wholly uncompleted by Y
X).(Y	X wholly excluding and wholly excluded from Y
X (.) Y	X wholly complete of and wholly completed by Y

Each particular has also two characters: and by each character is inferentially attached to a universal. Thus X () Y affirms that X is partially or wholly included in Y, and that X partially or wholly includes Y: and X (.(Y affirms that X is partially or wholly excluded from Y, and is partially or wholly complete of Y.

Again, four of the relations may be called *greater*, and four *less*. A greater relation is one which cannot be changed into its contrary without subtraction: a lesser relation is one which cannot be changed into its contrary without addition. The greater relations are ((, (., (.(, (, (, being all of which the minor term is particular: the lesser relations are))),).(,).),)(, being all of which the minor term is universal. The Aristotelian collection includes the lesser universals and the greater particulars.

Each universal has a *contranominal*, with which it may coexist; and two *extreme*¹ *contraries* or *extreme contradictories*. Thus X)) Y has the contranominal X (((Y = x)) y and the extreme contraries X).(Y and X (.) Y.

Hence we see the connexion of each universal with two inferred particulars. Each partial proposition asserts the existence of an indefinite share of the extreme extent by which the universal is *toto orbe divisum* from one of its extreme contraries. Thus 'wholly included in' which is also 'wholly incomplete of', or))), necessarily contains 'partially included in' and 'partially incomplete of', (.) and)(, which are indefinite contraries (commonly called *contradictories*) of).(and (., of each of which)) is an extreme contradiction. The connexion of the contranominals, through their extreme contraries and the particulars, is illustrated in the adjacent table (W., wholly; P., partially). The lines may also be read backwards, the spicular symbols being still read forwards.

¹ I hold by the amalgamation of the words *contradictory* and *contrary*, in spite of the disapprobation of some who have approved various points of my system. And this I do first, because the common language makes synonyms of the two: he who contradicts maintains the contrary. And this even from the mouths of persons versed in technical logic. Dr Clarke said of Collier the idealist "he can neither prove his point himself, nor can the *contrary* be proved against him."

Secondly, the etymology does not support the distinction. Thirdly, the true opposition is that of any contradiction and the extreme or total contradiction. "All are"; contradiction, some (perhaps all) are not; extreme contradiction, *none are*. Fourthly, the existing terms hide the distinction, and give a notion which makes a logician say, "so far from being the contradictory, it is not *even* the contrary."

)	(.)	<	(.....)	.)	(.....)	>	(.....)	.)	((
W. included in		P. excluded from		W. excluded from	=	W. excluding		P. excluding		W. including	
((.....	.)	<	(.....)	>	(.....)	>	(.....)	.)	W. incompleting of
W. uncompleted by		P. completed by		W. completed by	=	W. complete of		P. complete of		W. incompleting of	
)	>	(.....)	.)	(.....)	.)	<	((
W. included in		P. included in		W. excluded from	=	W. excluding		P. including		W. including	
((>	.)	(.....)	(.....)	.)	<))				
W. uncompleted by		P. uncompleted by		W. completed by	=	W. complete of		P. incomplete of		W. incomplete of	
.)	(.....)	(.....)	<))	>	.)	(.....)	(.....)			
W. excluded from		P. included in		W. included in	=	W. incomplete of		P. incomplete of		W. complete of	
(.....)	.)	(.....)	<	((>	(.....)	.)	(.....)			
W. completed by		P. uncompleted by		W. uncompleted by	=	W. including		P. including		W. excluding	
.)	(.....)	.)	>	(.....)	.)	<	(.....)	.)			
W. excluded from		P. excluded from		W. included in	=	W. incomplete of		P. complete of		W. complete of	
(.....)	>	.)	((.....	.)	<	.)			
W. completed by		P. completed by		W. uncompleted by	=	W. including		P. excluding		W. excluding	

In this table contradiction is denoted by a dotted line; and ascent or descent by the algebraic signs for *less* and *greater*.

Common language proceeds as if the part were more worthy than the whole, as a notion on which to base enunciation. Accordingly, we are familiar with *inclusion*, *exclusion*, and *partience* of both: but *completion*¹ and *coinadequacy* are strange and heretical. I have somewhere read of a speculator who maintained that every world has, in some other part of space, a counterpart world of defects equal and opposite to its own. If his system be true—all questions about other stars or planets are quite open—there is somewhere a planet in which thought fixes upon *whole* in preference to *part*; in which the concept of *penultimacy* is more familiar than that of *singularity*; in which the demonstrative pronoun is not *this*, but some word of the force of *all else*; and in which, at this moment, some antimathematical logician—for the mathematical tendency is in excess in the logic of *our* counterpart—endeavours to force attention to *exclusion* and *partience* upon a community which is too exclusively familiar with *completion* and *coinadequacy*. I have amused myself with constructing enunciations and syllogisms as they are in the exemplar-counterpart forms of our counterpart planet; from which

¹ Mr Spalding (VIII. 166) says that all the *eight* forms are set forth by Boethius. I cannot find them. Boethius does indeed apply the *four* to privatives, and so obtains equivalents of the eight onymatic forms: but I cannot detect him evolving relations *between the given terms* by help of their privatives. But he is rather prolix; and perhaps some reader may favour me with a definite reference to something which will support Mr Spalding's assertion. If not, that assertion is one of a very numerous class, of the bad consequence of which no one can form an idea who is not familiar with the history of discovery.

Two things are affirmed to be the same because the passage from one to the other is easy in the mind of the affirmant, after study of both: they are *virtually* the same, one *amounts* to the other, &c. This was Solomon's practice, or he never would have said that there is nothing new under the sun. I once had a private discussion of several long letters which might have been spared if my correspondent had said at first what he said at last, that certain two methods were the same *to all intents and purposes*: he began by saying they were *the same*; which is quite a different thing.

planet I myself may have come, if there be any truth in the doctrine of transmigration. If any of those who are too firmly rooted in our common notions will do the same, they will derive the same sort of benefit which young arithmeticians—who all think that 10 *must* be *ten*—derive from constructing systems on another radix. We want a better balance of logical correlatives. The original tendencies of language, partial, one-sided, stopping at just enough, have tied some of our mental muscles until they only act by special volition and a good deal of it. And we appeal to the defect in proof of the necessary character of the ligatures; to the incapacity of the slave in proof of the inexpediency of emancipation. As to untying a ligature, that would be extralogical and *material*.

Every *universe of objects* has its *universe of relations*, to which I now come. At the outset I am met by a difficulty which is shared by writers on perspective, and no way of escape is better than theirs. They cannot put solid objects into a book: so they draw a perspective figure to be the object, and then draw a tablet, a painter, and a collection of rays projecting the object on the tablet. Imitating this plan, let the symbols 1, 2, 3, 4, &c. be attached to the objects of the universe as, in the strictest sense, *proper names*: it being understood that these names imply no quality, and are assigned to the objects at hazard. Objects are thus distinguished by their *ἀριθμοί*, the word being used in the true Greek sense described in my last paper. What are commonly called *proper names* are frequently nothing but *singular names*, derived from notions of class; Horatius Flaccus shews both genus—or at least *gens*—and difference.

We have a right to treat *any* collection of objects, from one inclusive upwards, as a class; to be distinguished from the contrary class, containing all other objects, by a *mark*. I am not afraid, at this time, of being met by the old dictum that the differentia of a species¹ must be *of the essence*: but a little of the spirit of this demand may yet be left. Some may be disposed to think that *selections* exist—they will not say *classes*—the individuals of which really have no common difference, nothing which distinguishes them, and them alone, from all other things. I challenge such a selection. While awaiting an answer I imagine an ac-

¹ This is a question on which heretics have differed. Cicero affirmed *Trojan* and *Theban* to be species of man. Ludovicus Vives, heretic, and Johannes Rivius, orthodox, declare Cicero wrong, on the ground that the species must have an *essential* difference. Marius Nizolius, a worse heretic, describes them as “*quorum uterque audet reprehendere Ciceronem*”, forgetting that Aristotle, on various points, is described by himself through four long books (*De veris principiis et vera ratione philosophandi*, contra *Pseudo-philosophos*, 1553) as *Philosophaster* and *Pseudo-philosophus*. I give his distinction of species, husk and all:—“*Quis te docuit, O inepte grammaticule, hominem, etiam si extra ordinem substantiæ non egrediamur, non posse esse verum genus Thebani et Trojani..... Quare tu quoque discere verum esse id quod dicit Cicero, Trojanum et Thebanum esse veras hominis species, si non essentielles ad certe accidentales, et cognosce ea, quæ tu ex aterquilinio dialecticorum hauriens contra Ciceronem nugaris, nihil aliud esse nisi meras insanias.*”

Nizolius, great as the author of the *Thesaurus Ciceronianus*,—we have seen how sensitive he was on Cicero—is in logic

a small handler of a large theme; and very scurrilous withal. G. L. (whom Tiraboschi and others assert to be Leibnitz, whose initials were G. G. L.) republished the *De veris Principiis* in 1674, with a preface. But G. L. according to the Bodleian catalogue, altered the title into ‘*Antibarbarus philosophicus; sive philosophia scholasticorum impugnata*’: in other words, Leibnitz (?) saw that Nizolius was more useful against the schoolmen than in favour of truth. Tiraboschi leaves every one to decide for himself whether he will judge by the approbation of Leibnitz, or the disparagement of a modern writer, who expresses great surprise that Leibnitz should have published an edition. I judge by the book itself, which appears to me that of an emancipated slave, who made a new master of his liberty. Nizolius, arguing against what he supposes to be the scholastic doctrine, namely, that a genus contains only things present, strengthens the opposite opinion by the authority (*idem quoque confirmatur ab auctoritate*) of Julius Pollux, who, in what he says *περί γένων*, includes both ancestors and posterity.

ceptor; and I think I do nearly as well for him as he could do for himself, if I suppose him to select from the universe 'material object, past or present', as a lot which he defies me to difference from all other things, the following miscellany;—all men who have killed their brothers, the hundred largest ink-stands that ever were made, and Aristotle's dinner on his twenty-first birthday. What is the class-mark of these objects? I answer that to them alone belongs the epithet—'Selected by the fancy of (*here insert name and date*) in unsuccessful impeachment of the unlimited right of logical division'. I am willing to go further than Nizolius, and to divide species into essential, accidental, and perverse; affirming that the difference is extralogical. The more absurd such an instance as mine, the better does it make the claim asserted; Hamilton implied the like when he presented Newton and Leibnitz with their wigs awry.

If the number of objects in the universe be n , the number of possible collections which can be the selections denoted by *terms* is $2^n - 2$, the number of pairs of collections is $(2^{n-1} - 1)(2^n - 3)$ and the whole *universe of relations*, true and false, has $8(2^{n-1} - 1)(2^n - 3)$ instances, equally divided between true and false. Let the relations *species*, *exient*, &c. be denoted by the symbols $)$, $($ (&c: thus $X))$ and $((X$ both denote 'species of X '. When a symbol of relation is placed between two others, let it be read in the singular exemplar method; and let the two extremes be read *from* the middle term. Thus $(((\cdot)) ($ or $X(((\cdot)) (Y$ means to assert that 'Any one class is either species of X or external of Y ': and $X)))))Y$ means 'Any one genus of X is some one species of Y '. Of such possible readings there are 8.8.8, or 512, of which half are restrictives, and half are not.

I may be asked whether such methods of stating propositions are actually in use? I answer yes, sometimes in grave writing, and more often in rhetorical flourish, a kind of appeal to assent in which a little study of the characters of fallacy is not obviously needless. A certain sort of speaker wants to say that *all* Englishmen are lovers of liberty: for your stump-orator deals in nothing but universals, be the name of his stump what it may; a proceeding forced upon him by the lovers of his style, who consider a man of rules with exceptions as an equivocator and a loophole-monger. He declaims as follows:—'Show me any number of men, and I will say with confidence either that they will with one accord raise their voices for liberty, or that there are aliens among them.' This figure of speech is $X((Z$ expressed as $X(((\cdot) ($ (Z , where X is 'lover of liberty' and Z is 'Englishman'.

Every proposition is a *blank syllogism*: that is, every true proposition is a conclusion which has *middle extents*, whether the *terms* exist for them or not. Thus $X))Y$ is $X)) 0))Y$, where for 0 may be written any genus of X which is also species of Y . It is also $X) \cdot (0(\cdot)Y$, where for 0 may be written the contrary of any such intermediate class. Even the useless extreme $X))X$ may be written $X))X))X$. And the *blank syllogism* and the conclusion are convertible: thus $X))Y$ is $X))0))Y$, and $X))0))Y$ is $X))Y$. When the concrete middle term is inserted, this convertibility ceases: thus $X))Y$ is deducible from $X))A))Y$, but not $X))A))Y$ from $X))Y$. The essential of syllogism is the *existence* of the middle term, not its being this or that. The conclusion, as I have observed in a former paper, renounces all knowledge of the middle except its existence. That 'all man is mortal' is established by every one who shall prove that a genus of man is a species of mortal: the physiologist may have

to think of the middle term 'animal', the theologian of the middle term 'sinner'; but to both it is enough for the conclusion that a middle term exists. This explicit reduction of the middle term to mere existence is, I think, essential to the *formal* consideration of the syllogism.

In such a proposition as $) ((($, the spiculæ being, 12, 34, 56, let 12, 56, be *primary* relations, 34 the *secondary* relation, relation of the second order, or relation of relations. Let the spiculæ 3, 4, be *means*; 2, 5, *adjacents*; 1, 6, *extremes*. Take notice that the secondary relation is the common identification, or its denial: thus 12)56 is not '21X species of 56Y', but 'Any 21X is one 56Y, some 56Y'.

Of 512 secondary propositions, 256 are valid representations of unrestricted onymatic forms: the remaining 256 are either assertions or denials of restrictives. The unrestricted forms may¹ be obtained as follows: 32 of them are the forms of syllogism, with blank middle terms, and the secondary $()$; 32 more are the contradictions which deny that a middle term can be found, with the secondary $) ($. Three other sets of 64 each are found by varying the readings of the first 64 in the same manner as $X()Y$ and $X) (Y$ are varied by use of x and y for X and Y . Thus, the proposition $X((Z$ being a necessary consequence of $X() Y) (Z$ is an equivalent of $X() 0) (Z$, and of $X() ()) (Z$. That is, 'X genus of Z' is an equivalent of 'Some complement of X is some external of Z'. The denial is 'Any complement of X is not any external of Z', $X()) () (Z$, which is denial of $X((Z$, or an equivalent of $X) (Z$, or 'X deficient of Z'. The eight varieties, four of each proposition, are as follows, relaxing the exemplar form into ordinary reading.

- $X() ()) (Z$ Some complement of X is external of Z
- $X() (() Z$ Some complement of X is not partient of Z
- $X) () () Z$ Some class is neither coinadequate of X nor partient of Z
- $X) ()) (Z$ Some external of Z is not coinadequate of X.

Here are four secondary ways of saying 'X is genus of Z'. Again,

- $X()) () Z$ No complement of X is external of Z
- $X())) (Z$ Every complement of X is partient of Z
- $X) (()) Z$ Every class is either coinadequate of X or partient of Z
- $X) ((() Z$ Every external of Z is coinadequate of X.

Here are four secondary ways of saying 'X is deficient of Z'.

We can now give meaning to the 32 compositions which fail to show valid conclusion: they are all denials of restrictives. For instance $X ((Y)) Z$ gives no conclusion: and this is $X ((()) Z$. There is a term, says the proposition, which is both deficient of X, and species of Z. Of course there is, will be the first reply; must every species of Z fill up X? Certainly not, unless every individual of Z be *all* X; that is, unless Z and X be singular and identical. Consequently, $X ((Y)) Z$ has a conclusion; it denies 'Any X is any Z'; and we have one of Hamilton's syllogisms, when the non-partitive 'some' is used. The secondary

¹ I did not obtain them so easily, for I worked through the 512 cases separately and independently, before I saw what, when seen, was also seen to be what ought to have been seen.

The reader may thus be made more sure of the completeness of my investigation.

form $X(\cdot(\cdot)(\cdot)(\cdot))Z$ affirms that no deficient of X is a species of Z , and affirms 'any X is any Z ', or denies that 'Some X is not some Z '.

Again, $X(\cdot((\cdot))(\cdot))Z$ expresses that some class is deficient both of X and Z . To deny it is to say that every class is genus either of X or of Z , which gives only two individuals to the universe, one X and one Z .

The law which regulates these cases is very easily given. First, when the invalid form is either a universal and a particular, or two particulars of unbalanced middle terms, as $((\cdot)(\cdot)(\cdot)(\cdot))$, $(\cdot)(\cdot)(\cdot)(\cdot)$, or $(\cdot)(\cdot)(\cdot)(\cdot)$, $((\cdot))(\cdot)$. Let there be two singular and identical terms, of course with penultimate and identical contraries. When X is particular, let it be one of the singular terms; when X is universal, let it be one of the contraries: and the same for Z . The proposition which the (hitherto) invalid form denies is then constructed. Thus, writing down the instances of the universe, with their designations, we have four cases, under which are written all the combinations which deny them.

X x x x x...	x X X X X...	x X X X X...	X x x x x...
Z z z z z z...	Z z z z z z...	z Z Z Z Z...	z Z Z Z Z...
$((\cdot)(\cdot)(\cdot)(\cdot))$	$((\cdot)(\cdot)(\cdot)(\cdot))$	$((\cdot)(\cdot)(\cdot)(\cdot))$	$((\cdot)(\cdot)(\cdot)(\cdot))$
$(\cdot)(\cdot)(\cdot)(\cdot)$	$(\cdot)(\cdot)(\cdot)(\cdot)$	$(\cdot)(\cdot)(\cdot)(\cdot)$	$(\cdot)(\cdot)(\cdot)(\cdot)$
$((\cdot))(\cdot)$	$((\cdot))(\cdot)$	$((\cdot))(\cdot)$	$((\cdot))(\cdot)$
$(\cdot)((\cdot))$	$(\cdot)((\cdot))$	$(\cdot)((\cdot))$	$(\cdot)((\cdot))$

Thus $X((\cdot))(\cdot)Z$, or 'a middle term is both genus of X and partient of Z ' denies that Z is singular and X its contrary: and the same of five others, $(\cdot)(\cdot)(\cdot)$ &c. Secondly, when the invalid form has two particulars with balanced middle terms, let terms and contraries be both singular; the cases in which X and Z have balanced quantities deny that X and Z are contraries, the cases in which X and Z have unbalanced quantities deny that X and Z are identical. Thus

\therefore or $\frac{X}{z}$ is denied by $((\cdot)(\cdot))$, $((\cdot)(\cdot))$, $(\cdot)(\cdot)$, $(\cdot)(\cdot)$

\therefore or $\frac{X}{Z}$ is denied by $((\cdot)(\cdot))$, $((\cdot)(\cdot))$, $(\cdot)(\cdot)$, $(\cdot)(\cdot)$

To produce the forms which affirm the restrictives, we must have recourse to the secondary $(\cdot)(\cdot)$.

I return to the cases which are without restriction. There are three balances, which I shall call primary, secondary, and tertiary. The primary balance is even when the primary relations are both universal or both particular; uneven in other cases. The secondary balance is even when the spiculæ of the secondary relation are both universal or both particular; uneven in other cases. The tertiary balance is even when the primary relations are both Aristotelian¹, or both otherwise; uneven in other cases.

1. When the primary and secondary balances are of the same name, both even or both uneven, the primaries agree with their adjacent means or differ from them, according as the

¹ These are species, extant, external, partient; $((\cdot))$, (\cdot) , (\cdot) ; lesser universal or greater particular; the first spicula of the same name as the proposition.

secondary is *universal* or *particular*. Thus (()) () is admissible; both balances uneven, universal secondary, primaries of the same name as their mean adjacent spiculæ. If U and P denote *universal* and *particular* propositions, *u* and *p* similar *spiculæ*, so that, for instance, uUp denotes a universal proposition of universal and particular spiculæ, as))), then the legitimate combinations in which the primary and secondary balances are of the same name are U, uUu, U; P, pUp, P; U, uUp, P; P, pUu, U; P, uPu, P; U, pPp, U; P, uPp, U; U, pPu, P.

2. When the *primary* and *secondary* balances are of *different* names, the *tertiary* balance must be *even*.

3. To determine the *product*, or resulting simple relation, take the extreme spiculæ, invert each one which has a universal mean nearest to it, and make the result negative when the data show one or three negatives.

4. Given a product, to determine all the cases of which it is the product. Choose a secondary; treat the given spiculæ as in the last rule; distribute signs of negation so as to have none, two, or four, in all (product included); and supply adjacents in any manner which will satisfy the rules.

For example () (·) () is valid; universal secondary, primary and secondary balances both even, and particular primaries with particular mean spiculæ; and (·) results. That is, 'X complement of Y' means that 'Any term is either partient of X or of Y'. Again, (·) (·(·)) is valid: secondary relation particular, primary and secondary balances both uneven, universal and particular primaries with particular and universal mean spiculæ; the result is (·(·. Also, (·) (·(((is valid, for the primary and secondary balances are of different characters, and the tertiary balance is even, neither primary being Aristotelian; and the same of (((·(·) (in which both primaries are Aristotelian. It must be remembered that the primaries are read *from* the secondary spiculæ. Thus the last is 'some *species* of X is not any external of Y'.

These rules are not complicated, considered as selecting 256 out of 512, and deciding on their results. But any one acquainted with the canons of onymatic syllogism will find it easier to change the secondary into)·(or (), according as it is universal or particular, and then to try the primaries by the rules of syllogism. For instance (((·((). If we contravert the right-hand mean spicula and primary, we have ((())·(·: and X ((Y)·(Z is a pair of premises with the valid conclusion X (·(Z.

If space would permit, much might be said on the relations of the forms of syllogism in which the secondaries are () and)·(·. The first must be used in practice, almost exclusively; namely, the proof of the existence of a middle term by its actual production. The second is well known in thought, though its method of procedure, the denial of the existence of any middle term whatsoever, can but seldom be a direct means of establishing a conclusion. Thus X)·(Z, presented as X ((·(·)) Z, is a familiar type of thought: instead of 'no X is Z', we see that 'X and Z have no species in common'. The assumption that inference must proceed upon a comparison of two terms with a third is shown to be only an incident of that bisection of system which begins in the refusal of privative terms. That there is *no* middle

conclusion has 24 ways in which it can be announced with a secondary of its own quantity; and 8 ways with a secondary of the other quantity. I write down all the ways of announcing the conclusions)) and ().

Conclusion))

(()) ())·(()·((()·()·()·() ())) ()) (·() ((·()) (·((·((·()·()))
(·))))·)) (((((·))·((() (·))·))·(() (·) ()) () ()·((·() (())·())·())·(() (·) ()) () ()·((·() (())·())·()
()) ())·((()·())·()·()·((·) ())		
(·()))·)) (((((·()·((()) (·))·)		
(()))))·(((·((()·((·()·())))		
(·)) (·)) ((() (·))·() () () (·) (·)		

Conclusion ()

((())))·)) ((·((((·((·()·)))))))) () (·((()·()))·()·((·((·) ())
(·) () (·)) () () (·) (·() () (·) (·)))·()))·) () (((()·()·((() (·))·)
() ())))·() ((·(() (·((·()·())))		
(·(() (·)))) () ((·((·() ()))·())		
((() ())·)) ()·((((·()·()·))) ()		
(·) ())·)) () (((·) (·((() (·))·)		

The common syllogism has a *conjunctive* relation of premises: as in)) ()) which asserts terms—generally proved by assigning one—which are both genus of the minor and species of the major; or as in)·() (·), *i. e.* there are terms which are both external of the minor and complement of the major. But there are *disjunctive* relations of premises: as)·((·) (), any term is either external of the minor or partient of the major. When the secondary is thus disjunctive, the canon of validity is simply inverted as to universal and particular, and the canon of inference as to affirmative and negative. Thus (·((·))·) gives inference, because both premises *are* particular; and the conclusion is negative, (·): if *every* term be deficient, either of the major or the minor, these last are complements. Similar observations may be made on the secondary)(. The eight methods offer a crowd of analogies which I shall not describe. Taking () for a standard secondary, the universal syllogisms comprise all the cases in which the primary and secondary balances are of the same character, and the tertiary balance uneven: when this last becomes even, we have the strengthened syllogisms. In the particular syllogisms, there is even tertiary balance. The fourth case, uneven tertiary balance accompanied by difference of character in the other two, does not give any unrestricted forms.

I now make a selection from the 512 identifications, in illustration of the danger of asserting completeness without a very cautious examination. No one will deny, whatever he may think of the system, that it *is a system*, and that no portion of it could be selected as complete in itself with reference to all correlatives employed. Should any one object, his objection must affirm that the system is not yet complete, and that some higher power of 2 than 512 is the true number of cases. I take only one out of 32, as follows:—

pose. Over and above the reinforcement of preceding notions, that purpose is the comparison of extension and comprehension, or, as I prefer to say, of extent and intent. With the above limitations the following table, to be immediately explained, contains all that is necessary.

	I	II	III	IV
1)))))) (((((((())
2	((((((.))) .))) . (
3	()) (pw D ^o : wp ^o :	() () pp D ^o : ww ^o ==	((() pw ^o : wp D ^o :	() () pp ^o == ww D ^o :
4) (() pw ^o : wp D ^o :) (.) (pp ^o : ww D ^o ==	(.) () pw D ^o : wp ^o :	() (.) pp D ^o == ww ^o :
5	())) wp ^o : ww ^o ==	() ((pp D ^o : pw D ^o —	((() pp ^o == pw ^o ==	() () wp D ^o — ww D ^o :
6) (() wp D ^o == ww D ^o ==) (.) pp ^o : pw ^o —	(.) () pp D ^o == pw D ^o ==	() (() wp ^o — ww ^o :
7))) (pp ^o == wp ^o ==)) () pp D ^o : wp D ^o —	((() pw ^o == ww ^o ==	(() () pw D ^o — ww D ^o :
8	((() pp D ^o == wp D ^o ==	((.) (pp ^o : wp ^o —) .) () pw D ^o == ww D ^o ==) . () pw ^o — ww ^o :

Take one of these readings, for instance I. 6) ((, say X) (((Y, where X) may be either 'Any part of X' or 'some whole of X' and the same of (Y. There are four readings; *ww* (whole and whole), *wp*, *pw*, and *pp*. Of these *pp* and *pw*, about which no remark follows, are unrestrictive readings, and give) ((with the middle spiculæ erased, or X) (Y. That is, 'Any part of X is *exient* of [not wholly contained in] any part of Y' and 'Any part of X is *exient* of some whole of Y' mean simply that 'X is external of Y', or that 'no X is Y'; and the converse. But *wp* and *ww* are denials of a restrictive, and both simply deny (D) that X and Y are penultimately identical. That is, 'some whole of X is *exient* of any part of Y', and 'some whole of X is *exient* of some whole of Y', simply say, 'It is not true that X and Y are coextensive and each taking up all the universe except one individual object.' When X and Y are anything but coextensive, or, being coextensive, anything but penultimate, some whole of X, X or X and more, is not wholly within any part of Y.

Take the symbol IV. 4 as an example, X (.) Y. Omit the secondary spiculæ: we have X (.) Y, which is the proposition symbolized. Read the secondary) (as 'is out of', 'is entirely excluded from', or 'entirely excludes'. Four readings are possible, from part to part, *pp*, &c. These four readings are

- pp*, Some part of X is out of some part of Y;
- ww*, Any whole of X is out of any whole of Y;
- pw*, Some part of X is out of any whole of Y;
- wp*, Any whole of X is out of some part of Y.

Of these the table tells us that only *pw* and *wp* are unrestrictive: that *pp* merely denies (D) that X and Y are singular and identical; and *ww* merely affirms that X and Y are singular and contrary. But *pw*, which affirms that Y and anything, up to penultimacy, leaves out some part of X, affirms, as we see, that all which is not Y is X.

I finish this part of the subject by noticing that in any proposition one *spicula*¹ may be read as a verb, subject to rejections on account of the production of restrictives asserted or denied. The modes of reading are:—

X), X is in; X(, X takes in; X(·, X is not in; X), X does not take in.
(X, takes in X;)X, is in X; ·)X, does not take in X; ·(X, is not in X.

Examples are seen in

X)) Y, All X is in Y; X(·(Y, Some X is not in Y;
X(·) Y, Any whole of X does not take in Y,

and so on.

I shall now sketch out the whole of which the Hamiltonian attempt is a part. It will not be worth while to reduce it to tables, because the complex syllogisms to which it leads are easily reduced to compositions of simple ones, and would really appear in this way, except only when they show the junctions of universals which are seen in the system of terminal precision. The particulars of this system are of very infrequent occurrence compared with the universals. My object in giving this account is not to detail the system as for use, but to make it a lesson upon the necessity of giving full action and equal prominence to all sides of every correlation: and further, to show that the defects of an incomplete system are magnified when the part selected from the whole system is not an *aliquot part*. The Aristotelian table of enunciation, for instance, is a true bisection of system: it selects the lesser universals and the greater particulars. But the system of syllogism is not a true bisection: *nineteen* syllogisms cannot be a real aliquot part of any system. I postulate—in my own mind I say I have demonstrated—that the eight onymatic forms are essential to any complete system of enunciation.

We are to take in both *all* and *some-not-all* as quantifiers: that is, ‘some affirmed to be all’, and ‘some denied to be all’. At the outset then we are asked to select two out of three alternatives, without allusion to the third. We know that Xs, if Xs enter into thought at all, enter as *some*; and this *some* is either affirmed as all, or neither affirmed nor denied as all, or denied as all. Any *some* must appear in enunciation under one, and only one, of these three relations to *all*. The Aristotelian system makes a fair bisection of this set of alternatives. When there are three alternatives of which one is equally and symmetrically related to

¹ The “mysterious spiculæ” make a powerful language. In using one symbol,), as in X)Y, to denote both the total quantity of the subject and the particular quantity of the predicate, I followed the plan by which a fraction is represented, in which one symbol distinguishes both numerator and denominator: and I ultimately marked the symbol twice. If a fraction had been denoted by $\frac{a}{b}$, \underline{a} and \bar{b} would have been convenient symbols for a as a numerator and b as a denominator; and might be made useful even as it is. Forgetting that I was not writing wholly for mathematicians, I used expressions on this subject which were misunderstood. In my magazine of animadversions (VI. 650*) there is a spirited criticism of my notation, the colouring of which is heightened by assuming to be *one* my *two* syllogistic notations, pictorial and arbitrary;

the first only a study, the second a language for use. In it we find—“We need hardly, therefore, be surprised, that, in the end, Mr De Morgan should actually laud the farrago for expressing *diametrically opposite* things (“the universality of the subject,” “the particularity of the predicate”) by the *self-same* representation.” Had I held, with the logicians, the exclusive right of the onymatic relations to be logical forms, I should now have dropped the word *spicular*, already borrowed from Hamilton, and have substituted *farraginal*, with the motto

Quicquid agunt homines nostri est farrago libelli.

If, as I suspect, I am on the way to a much wider use of the complex forms), (·(, &c., the second adjective may yet find an introduction.

both of the others, that one may be repeated twice, once in relation to each extreme: and either extreme, with the common mean, is a symmetrical bisection of system. The Aristotelian plan confines itself to 'some affirmed to be all' and 'some not affirmed to be all': one extreme, and the mean in relation to it. But if we take the *two* extremes, we must also take the mean in its relation to both. Again, as contrary terms must enter, whatever subdivisions we make of 'some X' we must also make the same of 'some x'. Accordingly, since a universal term gives a particular contrary, there is no proposition but must enter in four different ways. A term being universal, we must distinguish the case in which the particular contrary is to be *some-or-all* from that in which it is to be *some-not-all*. Denoting *all* and *some-or-all* in my usual way, I shall denote by an accent that the particular term indicated is *some-not-all*, or else that the universal indicated has *some-not-all* for its contrary. There are then, besides the *eight* usual forms, 3×8 or 24 others, all formed, as we shall see, by conjunctions of two of the eight, or three. These last, by equivalences, are reduced to *twelve*; which with twelve disjunctive denials, make a total of 32. Of these I shall, for brevity, consider only the common forms and the 12 conjunctives: syllogisms containing disjunctions can be dealt with by opponent reduction.

First, a universal, such as $)$, is accompanied by $)'$, $)'$, and $)''$. The three last are equivalent, and equivalent to the form $)$ joined with $)$; or to $)$. And the same of the others. So that the system of universals contains the *simple* universals $)$, $(($, $($, and the *double* universals $)\circ$, $(\circ$, $)\circ$, $(\circ$.

Secondly, a particular, such as $($, is accompanied by $(')$, $(')$ and $(''$. These three have the following meaning. Each one consists of the proposition without the accent, joined to the proposition in which the unaccented term is contraverted. Thus $(')$ is $($ and $)$; $(')$ is $($ and $($; $(''$ is $($ and $)$ and $($. These may be denoted by (\cdot) , (\cdot) , and (\cdot) . Accordingly, we have

$(')$ and $)'$ mean (\cdot)		$(''$ means (\cdot)
$(')$ and $('$ mean (\cdot)		$('\cdot'$ means $)\cdot($
$)'$ and $('\cdot'$ mean $)\cdot($		$)'\cdot'$ means (\cdot)
$)'\cdot'$ and $)'\cdot)$ mean $)\cdot)$		$)'\cdot($ means $)\cdot($

Remember that $)\cdot($ is the triple junction of $)$, $)$, $($, $($, &c. Contranominals do not appear in any double proposition: thus we have not equivalence, $)$ and $(($, nor contrariety, $)\cdot($ and $($, nor (\cdot) , nor $(\cdot$ and $)\cdot)$.

The denials may be represented by the disjunctive comma: thus the denial of $)'$ is 'either $(($ or (\cdot) or $)'$ ', represented by $\{(($, (\cdot) , $)'\}$. Of the whole number, Hamilton's plan selects *seven*, when 'Some X is not some Y' is properly treated, and adds the assertion of equivalence 'All X is all Y'. The seven are

$$)\circ, (\circ, (')',)\cdot(, (, ('()\cdot)';$$

being two simple propositions, four double, and one triple. It thus includes all the cases in which the new forms, (\cdot) and $)\cdot($, are absent. To these it adds the equivalence, or junction of $)$ and $(($, without adding the junction of $(\cdot$ and $)\cdot)$, the denial of $\{ \}$, $\{ \}$. The

junction of contranominals is, in every one of its four cases, excluded from separate enunciation by the main principle of this system. If Hamilton had expressly started on the principle of allowing every Aristotelian proposition, every possible junction, and every disjunctive denial, with simple conversion, he would have come very near a system.

The syllogisms of this system are, when it is fully taken,—1. The 32 forms with two single premises each. 2. Eight universal forms with double premises and double conclusion, being those I have called syllogisms of terminal precision; and 16 opponents, having one disjunctive premise and a disjunctive conclusion. 3. Various forms in which a single universal—or a double one, which gives only a strengthened form with the same conclusion,—with a double particular, give a double particular. 4. Various forms in which premises one or both of which are more than single give only a single conclusion. On these it is not necessary to dwell: any case is resolved at a glance by any one familiar with my notation.

I cannot undertake, in the present paper, to give a full account, in relation to aggregation¹ and composition, of the distinction of *extent* and *intent*. I shall therefore confine myself to what I expect will be a termination of my controversy on this point, followed by a brief account of what I hold to be the true logical foundation of the distinction.

No part of Hamilton's system has received a more ready assent from his followers than his mode of making the distinction—I say his substitute for the distinction—which Aristotle announced when he divided *genus in species*—attribute in attribute—, from *species in genus*—class in class. I shall not, after what is said in my third paper, offer any further proof that there is a substitution. It will be enough here to quote (VI. 642*) his governing² principle—"the predicate of the predicate is, with the predicate, affirmed or denied of the subject"—which ushers in the form of *depth*, or comprehension, "All X is some Y", as distinguished from that of breadth, or extension, "Some Y is all X". When we say, says

¹ This distinction is not yet seen, nor, I fear, will it be seen until the logician is restricted to puddings which are only *aggregates*, and not *compounds*. It is remarkable that we have no word of pure English which designates the part as a component: *element*, *constituent*, *ingredient*, *component*, *material*, are all foreign. Shakspeare's witches talk of *ingredients*; but they were scientific characters: the word can be distinctly shown to have been limited to medicines, charms, &c. What would a housewife of the time of Elizabeth have said, when she told her servant not to forget the ——— for one of those puddings which I would withhold from the logician. The *things* or the *stuff* will suggest themselves; but they only prove the absence of the truly distinctive word. For *things* may be aggregants as well as components: and *stuff* is the proper term when there is but one kind of material; though, for want of better, it occurs in such words as garden-stuff, kitchen-stuff. And the word applies equally to aggregants and components.

² The word predicate is here loosely used. The first time it occurs it means 'predicate affirmed': in the two other cases it means 'predicate affirmed or denied'. Hamilton's readers must be cautioned as to the very positive way in which he puts forward bran new principles as though they were generally received, and convicts those who deny them of mistake, by appeal to the principles themselves. For example, (VI. 642*):—"This suffices to show how completely Mr De Morgan mistakes the great principle:—*The predicate of the predi-*

cate is, with the predicate, affirmed or denied of the subject." Would not any one suppose it to be notorious that this great principle had been previously announced by others? Be this as it may—I assert no negative, but I cannot find it—I had denied this principle, in effect, though I had never heard it, by proceeding on principles repugnant to it. When I say a horse has four legs, I ought to be taken as *denying* the great principle of bipedality, not as counting each leg twice in an attempt to *apply* it. In the point before us the Port Royal logicians have *repugned* the 'great principle' as well as myself, and to all appearance with no more knowledge of its existence than myself; and Hamilton proves his knowledge of their opinion by citing them—very correctly, I believe,—as the restorers of the distinction of extension and intension. I may slightly mention another point. Hamilton thinks it sufficient to answer his opponent's meaning by fixing another meaning on his opponent's words. I designated a proposition of his as *spurious*, referring to a page of my own book for my own technical use of that word. Hamilton (p. 639*) begins his answer thus, "*Spurious* in law means a bad kind of *bastard*:" and on this definition he easily convicts me of absurdity. If, under a definition of my own, I had called his proposition *goniometrical* instead of *spurious*, he might well have impeached my Greek; but it would have been of coequal absurdity if he had answered me by solemnly proving that he had not enunciated a theodelite.

Hamilton, that Leibnitz, a mathematician, is not Newton, we deny "mathematician" of Newton; not "any" mathematician, but the mathematician incorporated in Leibnitz; Newton is not the LmaEtheImaBNtiIciTanZ who is here spoken of. He means that each quality residing, inhering, in a subject is an object of thought, *per se*, as a quality, distinct from, though a component of, the subject of inhesion, and from the same quality in any other subject. All this can be thought: what is its force as a distinct mode of enunciation? and what is its utility in logic? Show me the first, and I can undertake to find the second.

Two objects are in a certain particular alike, so that if they were as much alike in all particulars they would be the same object. If Leibnitz, besides mathematician, had been English, Fellow of Trinity, Lucasian professor, &c. &c. &c. he would have been Newton: and the proper name Leibnitz would have been but an alias of Newton. What! it will be asked, do you deny that in thought you can conceive two men, facsimiles in body and mind, thinking, speaking, and acting, exactly in the same way, &c. &c. &c., all through their lives? If the querist mean that they are to differ in *place* or in *time*, I can conceive two *different* men, each the double of the other in all things except place or time. But if, among the other samenesses, they be to occupy the same place at the same time, I cannot call them *two* men. If I could, I should say there is no such thing as an individual; that each one man is a hundred, or a thousand, agreeing in all things, place included, at all times, and therefore without distinction. Suppose one individual to differ from another only in one quality, the first being $AXYZ\dots$ and the second $BXYZ\dots$, A and B being repugnant. Hamilton says they have two different X qualities, X_1 and X_2 : let it be so; the individuals are then $AX_1Y_1Z_1\dots$ and $AX_2Y_2Z_2\dots$. If A and B had chanced to be the same, these two individuals would have been wholly without distinction—would have been the same. Remember that we are supposed to have enumerated *every* concept under which either is viewed or which either receives or creates. If then, which I do not deny, X_1 and X_2 be really different examples of the same quality, all knowledge of this difference—the very difference itself, as to the *esse quod habet in anima*—is due to the difference of A and B. What then is the logical import of a method by which, because there are differences which distinguish, we read samenesses into *different samenesses*, and contend that agreements, as such, have differences of which only disagreements wholly independent of the agreements make us cognizant.

Again, why do we give a class-mark, a term-name? to distinguish the objects of the class from all others, and (*pro tanto*) to *confound them with one another*. As against all other species, each is *signatum* by the class-mark; thus, though there be many *men*, I distinguish Newton and Leibnitz by the attribute *humanity* from each and every *brute*. But as against each other, this common class-mark is *vagum*: though I know each to be *man*, I do not know them to be *different men* till I have found another class-mark, the property of one, but not of the other. When the Irishman had caught the cluricaune, and made him show under which thistle out of many acres of them the treasure was buried, he tied his garter round the thistle—he added one¹ additional class-mark—and ran home for

¹ The logician must not say that he merely distinguished an individual, and did not include in a class: independently of the truth, sometimes denied, that a class may consist of one

individual only, his own remaining leg, and many other legs, were fellow-members with the designated thistle.

a spade. But the imp, while he was gone, tied a garter of exactly the same form and colour over every thistle in the field. When the poor man came back, he was made sadly sensible of the impossibility of distinguishing two individuals by the difference of their points of agreement. Hamilton would have described the situation to him as follows (VI. 643*):—"Let us consider what is meant by the proposition,—“This thistle has a garter.” “A garter” does not here imply *all*, *every*, or even *any* garter, but *some* garter,—a *certain* garter; and this *particulare*,—be it *vagum*, be it *signatum*,—this *some* or *certain* garter which we affirm to be on this thistle, we do deny to be on that, in denying this to be that.” To which the Irishman might reply;—"True for you, your honour! but what will I be the better of that? Sure its the *signatum* I'm wanting, and the *vagums* are of no use at all at all." And this is the true answer. If we only know that the garter on this thistle is not the garter on that, by (otherwise) knowing that *this* is not *that*, we have nothing that we can enunciate about garters as giving knowledge of this and that. Any one who can make a *formal* profit of the *differentiæ* of undistinguishable class-marks, may make a *material* profit of the cluricaune, if he can catch the creature. In the mean time, he may employ himself in studying how to advise the little boy who had two shillings, and was puzzled to find out which he ought to spend first, to make his money go farthest.

I hold this distinction between “Every man is in the class animal” and “Every man is an object in which inheres one quality animal” to be of small meaning and no use. To make it the great distinction between the two sides of logic seems to me solemn trifling: to symbolize it by the inversion of phrase in “Some animal is all man” and “All man is some animal” is to bring distinction without difference in aid of difference without distinction.

In my third paper I gave a generalization of the old distinction of extension and comprehension (or intension) as the foundation of what I called the mathematical and metaphysical sides of logic. To all there laid down I adhere; but I add that the logical skeleton of the metaphysical side is connected with *whole in relation to part* just in the same manner as that of the mathematical side is connected with *part in relation to whole*. Every *attribute*, or concept by which a class is distinguished, makes many portions of the universe to be so many *wholes* in relation to contained parts. If the class X be a part of the class Y, the class Y is a whole of the class X, the attribute Y is a component of the attribute X, whenever we mean by the attribute X the *total attribute*, the compound of all possible attributes, possessed by X. The proposition is ‘X and every part of X’—not merely its *distinct* parts, but all possible parts—comes under Y and all its wholes. The correlation of part and whole has been so little examined that further detail may be necessary.

There are classes, X and Y, containing 20 and 30 individuals: they aggregate into a class of not less than 30 nor more than 50 individuals; and I must know how many individuals belong to *both* classes before I can assign the aggregate number; that is, before I can ascertain the *common whole* of which X and Y are *parts* I must know the *common part*, if any, of which X and Y are *wholes*: this common part may be of any number of individuals not exceeding 20. This is the principle which Mr Boole has formulised in $X+Y-XY$ for the aggregate of X and Y; and which determined my use of (X, Y) instead of $X+Y$ in my *Formal Logic*. I call the common whole of two parts their *aggregate*; the common part of two wholes their *compound*.

Suppose a universe of six individuals, of which the proper names, the representatives of singular attributes, are 1, 2, 3, 4, 5, 6. Let us consider the class X, or 1, 2, 3. This class has the parts, 1, 2, 3, 12, 23, 31, 123. It has the wholes, 123, 1234, 1235, 1236, 12345, 12356, 12346. But 123456, though a whole of 123, is not a term dividing the universe, which has six lowest parts, 1, 2, &c, and six highest wholes 23456, 13456, &c. Every selection is to have its name, which may equally designate the class and the attribute by which the class is distinguished; being at once the instrument of cumulation and of distinction: of cumulation, when one individual of the class is coupled with another; of distinction, when one in the class is separated from one of the externals.

Every point of correlation is seen, or will¹ be seen, to be perfect. The individuals being non-partient of each other, we may designate the class 1, 2, 3, by $1+2+3$. We have no symbol in mathematics which may by analogy be employed to designate the attribute of this class; nothing which suggests 'the common mark of 1, 2, 3, and of them alone': except so far as this, that A_{123} is sometimes used in such a sense, *inter alia*; which may therefore denote the common attribute. Suppose we describe the class $1+2+3$ as the *aggregate* of $1+2$ and 3 : what is the correlative mode of describing its attribute in terms of the compound of two? The answer is that a class may be described by its contrary, and 'that the alternative attribute of A_{3456} A_{12456} ' is the description of the attribute required. The relations of aggregation and composition are closely connected with those of direct and contrary: thus the propositions 'C is aggregate of A and B' and 'not-C is compound of not-A and not-B' are convertible.

The following is an example of the correlation of propositions.

$X \cdot (Y)$. No X is Y; everything either x or y: X and Y have no common part: but, if not complements, have common wholes. Every individual is in some of the parts either of x or of y: and is either not in some whole of X, or not in some whole of Y. That is, no junction of a new attribute selects any part of one out of the other: everything wants some attribute of one or the other.

$X(\cdot)Y$. No x is y: everything either X or Y: X and Y have no common² whole: but, if not externals, have common parts. Every individual is in all the wholes either of X or of Y, and is either not any part of x, or not any part of y. That is, no dismissal of an existing attribute makes any whole of one a whole of the other: everything has all the attributes of one or the other.

¹ A qualification rendered necessary by the smallness of the number who think of such distinctions. That *esse* is *percipi* is especially true of the *esse in anima*. The logical eye of the mathematician, and the mathematical eye of the logician, are yet to be opened. The cultivators of both the sides of exact science seem to proceed upon the notion that distinct vision is not possible with both eyes together. Some contend for the right eye, some for the left: and the voice of mankind finds no utterance; for *parmi les aveugles un bergne est roi*, let him have which eye he may.

² One word more on this stumblingblock. All terms have a common *whole*, the universe: but this is not a *whole term*. The logician does not see why the universe is to be excluded, nor can he see until his mathematical eye is open. But he

excludes it in his own system, and very easily, by never inventing a name for it. 'Every thing that exists', 'the *omne cogitabile*', are opposed in thought to their contraries, the non-existing, and the *incogitabile*. Where is the name that includes both the existing and the non-existing, the thinkable and the unthinkable? Let this name be shown, and shown in use, and then I shall be open to the charge of correcting the old logic: but I think I have only imitated it. In a full work on logic, the universal name might be discussed in the chapter which treats of *restrictives* and other extremes, not forgetting *vacuous* names. But in the logic of the term—*distinctive name*—the garter is as useless when all the thistles have it as it would be if none had it.

I shall be asked whether, when the intensive proposition is thus reduced to its skeleton form, as a relation between wholes, I do not abandon the distinction of *mathematical* and *metaphysical*, as designative of the two sides of logic. Is not the idea of a whole including a smaller whole as mathematical as that of a part contained in a larger part? Certainly it is, but nevertheless I do not abandon the nomenclature, which loses none of its truth and none of its utility: but the names must be held designative of a subsequent distinction. The proposition of extent remains mathematical to the end; the proposition of intent becomes metaphysical in application. Even when *man* and *brute* are clothed with all their qualificative concepts, they make up *animal* just as the items of a tradesman's bill make up the total of goods furnished. The individuals are plain counters in the formal enunciation, and painted counters in the material: but never anything except counters. But when, in the proposition of intent, the whole is recognized by its separating attribute, that attribute coalesces with others in each individual by a process of which we hide our ignorance when we call it ontological or metaphysical. The whole *rational* contains the whole *man*; the attribute *rational* goes to the composition of the attribute *human*: but, in spite of the logician, there is more than *summing up* in this second process. Extensive quantity has *partes extra partes*, as they once said, and some will admit no other kind of quantity: *de essentia quantitatis est habere partes extra partes*, says Smiglecius (*Disp.* ix, qu. 5). But extensive quantity has this quality objectively, permanently, and *de essentia*: intensive quantity has it only subjectively, *pro re nata*, as an accident of the thoughts. We can separate the rational in man from the animal in man, for the mind, by an act of the mind: we cannot but separate this man from that, save only when we think of the class as a unit, a process as subjective as that of separating the individual into concepts. First intentions give individuals which are compounds not yet decomposed, and aggregants not yet aggregated. Second intentions exhibit component attributes, and aggregate classes. The basis¹ of these oppositions is seen in X))Y under the forms 'X and all its parts are parts of Y'—'Y and all its wholes are wholes of X.'

¹ Mr Mansel (iv. p. 117—119) has some remarks on extension and intension, hinting opposition to Hamilton's doctrine, and recognising the change of the quantities in passage from one to the other. With him "some A is all B" gives all the attributes of B as some of those of A; while "all A is some B" classes A under B. This mode of enunciation is very confusing: and from it follows that I owe Mr Mansel reparation for all but absolute misrepresentation in my article *Logic* (col. 344, note) in the *English Cyclopædia*; an inattentive reader would suppose I make him merely change the places of Hamilton's forms, whereas he does more. Mr Mansel says (p. 119)—"The problem which we wish to see satisfactorily solved by the advocates of Sir W. Hamilton's doctrine may be stated as follows: To construct a synthetical proposition containing an equation or identification of subject and predicate in any other respect than that of the objects thought under the compared concepts." My position is, either that this question is now solved, or that the given problem is not the one which should have been given.

Mr Mansel criticises Bishop Thomson for not taking sufficient account of *constitutive* attributes as distinguished from simple *characteristic*: I hold that Dr Thomson—and others,

including the author of my second paper—had taken too much account of this extralogical distinction; extralogical, so far as entrance into enunciation is concerned. For a term is held to be divided from its contrary before enunciation: while, in the proposition, an attribute is of the same import whether it be constitutive, or only characteristic. Hamilton, from whom I seldom differ in principle as to what is and is not logic—though in application we sometimes so widely disagree that, like a professor I have mentioned elsewhere, I do not grant him that the whole is greater than its part until I see what use he wants to make of it—replies as follows:—"...In reference to Breadth and Depth, there is no difference whatever between 'constitutive' and 'attributive', between necessary and contingent, between peculiar and common. It is of no consequence, what has antecedently been known, what is newly discovered. These are merely material affections. We have only to consider what it is we formally think," (vi. 643^o). With reference to the quantities, Mr Mansel is answered by (644^o, note)—"As others, besides Mr De Morgan, have misunderstood this matter....." followed by a clear and dogmatical exposition of Hamilton's doctrine of breadth and depth, never till then given, and placing his error of quantity in broad daylight.

This basis of thought may now be introduced in my former papers as the mathematical substratum of the metaphysical notion: I need not enter into details. Both the systems of secondary relations may be adapted to it. In the second of the systems given above *pp* is the mathematical reading; *ww* the metaphysical; *pw* the physical; and *wp* the contraphysical: according to the phraseology of my third paper.

I need hardly say that, in like manner as any individuals may be selected, and constituted a class, so those same individuals may be distinguished by a term which denotes an attribute: we cannot put on a class-mark without acquiring a right to treat that mark as designative of a concept. When we pass from the arithmetical abacus to the use of terms of relation, mathematical or metaphysical, as *species*, *dependent*, &c. we shake ourselves free of many of the questions which I have discussed. Before we come to this point we feel a want as to (\cdot) and $)$ (of which we are inclined to complain until we see that only defective correlation prevented our feeling the corresponding want as to $)\cdot$ (and $()$ in another wing of the subject. I have frequently heard it made an objection to $X(\cdot)Y$ that it appears as 'Everything is either X or Y', of disjunctive character and apparently affirmative quality. So long as we have a copula either of identification or inclusion, we cannot read either (\cdot) or $)$ (by *part and part*. For this objection, as an objection, I have never cared: those who acknowledge the existence, and admit the entrance, of a privative term must needs confess that $X))Y$ and $x(\cdot)Y$ are equivalent. But I have always respected the complaint as merely directed against a blemish, and have awaited the time when further consideration would provide further explanation. The reader will see that this time has now arrived: the forms $)\cdot$ (and $()$ are subject to precisely the same difficulties with reference to *whole and whole*. The following table of correlative readings will illustrate this.

$X)\cdot(Y$.	$X(\cdot)Y$.
No part of X is any part of Y.	No whole of X is any whole of Y.
Any part of X is not included in (and does not include) any part of Y.	Any whole of X does not include (and is not included in) any whole Y.
Some whole of X is external of some whole of Y.	Some part of X is complement of some part of Y.
Every penultimate is whole either of X or of Y.	Every individual is part either of X or of Y.
Every penultimate includes either X or Y.	Every individual is included in either X or Y.
Every individual is not included in some penultimate either of X or of Y.	Every penultimate does not include some individual either of X or of Y.

And so we might proceed, never failing to translate a reading of either proposition into a reading of the other, strictly correlative in every detail.

I shall close this paper by attempting to procure for the quantification of the predicate an honourable acquittal from the charge of having disturbed the peace of the logical world. It has never been the subject of discussion, except by myself in the investigation of the numerical syllogism; an investigation of which the truth remains unquestioned, and in

which all quantification of the predicate is proved superfluous. Another notion, under the name of *quantification*, has stirred up controversy. I say nothing here about the mere question whether the quantity of the predicate should be *expressed*. The explicit demand for this expression was first made by Hamilton: it is a great step; and the logical world is pretty well agreed that its merit is quite distinct from the merit or demerit of the particular mode of quantifying which he adopted.

What is *quantification*? It means, or should mean, the giving or expressing of quantity; and as quantity is essentially a *more* or a *less*, the giving of quantity cannot exist without the giving of a more or a less. But the quantity of the predicate, be it more or less, is always the quantity of the subject, or its complement, as well in negatives as in affirmatives; that is, so far as it is more or less. I postulate that a proposition is only a proposition, a proponent, a challenger of assent or denial, in so far as, and with reference to, its assertion of what might have been deniable, or its denial of what might have been assertable. For example, in 'Every X is Y', it is a clear matter of affirmation, and so intended, that each X is X, and each X not more than one Y: but these are not put forward as parts of the proposition, because they are not *distinctive* parts. In propositions, as in terms, all that belongs to the whole universe of propositions is to be tacitly rejected: I claim to make the rejection explicit, because it is sometimes tacitly refused. This being conceded, if I say 'Xs are Ys' it is clear that the number of Ys spoken of is the same as the number of Xs: if that number be ten at most, then ten (or fewer) Xs are ten (or fewer) Ys. If I say 'Xs are not Ys', what I deny is that the ten (or fewer) Xs are any ten (or fewer) Ys: I do not mean to deny that the ten are *nine* or *eleven*; for that I can deny by the form of thought, let X and Y be what they may. If I say 'Everything is either X or Y' neither X nor Y has quantity until quantity is assigned to the other: in a universe of 100 instances, if 40 Xs go to the verification of this proposition, the number of Ys required for the same purpose is 60.

In treating the numerical syllogism, it appears that '*m* Xs are found among *n* Ys' is a proposition importing no more and no less than '*m* Xs are Ys'. Also that '*m* Xs are not found among *n* Ys', Xs and Ys being *x* and *y* in number, is *spurious*—that is, true independently of which are Xs and which are Ys—if $m + n$ be less than *y* or less than *x*; and otherwise, of the same import as ' $m + n - y$ Xs are not Ys' and $m + n - x$ Ys are not Xs.

Neither is the predicate of an affirmative more or less definite than the subject, as to *quiddity*¹, to revive an old term. If I say 'All Xs are Ys', I only fail to know whether

¹ This word, which was but badly replaced by *essentia*, has been selected as a joke against the old logicians: but *quantity* and *quality* are in honourable use. The joke may be retorted upon a discerning public, which, while treating the word with ridicule, fell into the error of theory which it may be supposed to favour, to every extent short of the absolute maximum. All we know of *quid* is derived from *quantum* and *quale*: if mankind had discarded *quiddity* on this ground, the race would have vindicated reason against philosophy with honour to itself, or at least would have shown an appearance of it. But, on the contrary, men in general assume a knowledge of things, *res ipse*, entities, essences, substances, natures, &c.; and they

claim to assert much about quiddity upon any the least knowledge of quantity and quality. One exception, indeed, their modesty does reserve: it is admitted, enforced, and made pulpit doctrine, that the Almighty is known only by his attributes, in a manner which implies that his creatures can be otherwise known. There was a time when educated persons, in numbers, had never heard of *attributes* in any other way; some may still be left. When a boy, I remember hearing murmured charges of irreverence against a person in company who spoke of the attributes of the vegetable world: my impression was that some of those present had a vague idea that the speaker might be a worshipper of leeks and onions.

this or that Y is spoken of by failure of definite knowledge of the Xs. If I say 'all man is animal', and cannot say that I have spoken of *that* animal, it is only because I do not know whether *that* object was spoken of under 'man'.

What notion, then, has been brought forward and discussed under the name of *quantity*? Distinction between affirmation and non-affirmation of *all* or *any*: totality affirmed, totality not affirmed, without any reference to the *quantity* of the *totum*, the more or fewer individuals existent in the class. To speak of X at all is to speak of the whole class, to speak of all X as a class, or not to speak of it as a class. 'Man is animal': do you speak of man as a whole class? yes; do you speak of animal as a whole class? I say nothing about it; you are to take this proposition for purposes of inference without knowing whether I speak totally or partially; there is neither assertion nor denial, but reserve; it may be that I know the truth; it may be that you know the truth; but this proposition says nothing about it, and is intended to say nothing. This is all that is meant by 'animal' being *particular*.

If this view had been taken from the beginning, the difficulties of the singular proposition and of the indefinite proposition would never have appeared. All the confusion which has arisen from want of care in stating the meaning of 'some' would have been avoided. The Hamiltonian quantification, if it had appeared at all, would have appeared in a sound form. It would have been remembered that affirmation and denial are not alternatives; and the three quantifiers of which I have shown the united effect would have been allowed full operation. To this I may add that Hamilton would never, even while denying its utility, have allowed 'most' (half plus some) to have been *legitimate*. This importation from truly arithmetical quantification would have remained in its proper sphere, in company with other fractions.

In my third paper I closed the controversy with my late opponent, as to every strictly personal matter: in this paper I hope to do the same with the purely logical questions, so far as his criticism on my own views is concerned. What remains of a polemical character—save only the question treated in the addition—concerns neither this logician nor that mathematician, but *the* logician and *the* mathematician. I believe that the necessary laws of thought constitute as wide a study as the necessary matter of thought: and that Kant's opinion on the finality of the Aristotelian system has as much truth and sense as any similar opinion—if any such were ever held—about the finality of the elements of Euclid.

To the logician I say that the system which he owes to a mathematician, Aristotle by name, is a system of which none but mathematicians have ever shown a disposition to extend or vary the forms which has been followed by general respect: as Boethius, Ramus, Leibnitz, Lambert, Kant. There is but one logician of great note who, not having mathematical habit, has attempted to depart from routine in the construction of a system of inference. It is not for me, appointed by himself his most prominent opponent, to pass sentence upon his system: but I suspect I have shown that system to be none the better for its author's ignorance of the other branch of exact science. The growth of logic has been stunted by its separation from mathematics: I feel certain that my learned and acute antagonist will be cited in time to come as the great champion of reunion, though appearing and intending to fight on the other side.

To the mathematician I assert that from the time when logical study was neglected by his class, the accuracy of mathematical reasoning declined. An inverse process seems likely to restore logic to its old place. The present school of mathematicians is far more rigorous in demonstration than that of the early part of the century: and it may be expected that this revival will be followed by a renewal of logical study, as the only sure preservative against a relapse.

UNIVERSITY COLLEGE, LONDON,
April 14, 1862.

A. DE MORGAN.

*. This paper has been before the Council since May 19, 1862, though circumstances caused the deferment of the reading until May 4, 1863.

ADDITION.

Since the communication of the preceding paper I have obtained some notice of my criticisms from Mr T. Spencer Baynes, who I hoped might have been able to give evidence from his own personal recollections of Hamilton's conversation and public teaching: this he does only on one of the points, referring the others to Hamilton's printed works. Some account of his remarks is necessary: they do not induce me to *alter* anything I have written; but, as noticed, I *omit* the detailed proof of the falsehood and incompleteness of many of the syllogisms, because I find that no opposition will be made on this point. I remain of opinion, and must so remain until further showing, of which I entertain no hope, that Hamilton did leave one set of syllogistic forms as recipients of both senses of "some", the old non-partitive sense, and his own doubly-partitive sense. That the neglect to make the necessary comparisons was a consequence of illness¹ I have no doubt. All the letters referred to appeared in the *Athenæum* journal: the dates are those of publication. As stated in the paper, I had brought forward Hamilton's phrase "*some at least* (possibly therefore *all or none*)": failing all attempt at defence, I had (Dec. 28, 1861) given my own method of excusing its occurrence. Mr Baynes defends Hamilton (Nov. 22, 1862): I abide by my explanation; and the matter is now left to opinion. The phrase carries its own condemnation with it; to those who cannot see this I have really nothing to say. But as my object in producing it was only to show the hurry of the article in which it appears; and as it belongs, not to Hamilton's system, but to his account of the old one; and as I have omitted

¹ Mr Baynes took no notice of my expressed conviction (Nov. 2, 1861) that "as to his [Hamilton's] passing what I have called the Gorgon syllogism as valid inference, after actual examination, there is no need to say that it was impossible he should have done it." My whole position was that he had allowed himself, without examination—and this probably owing to his illness—to take the whole application to syllogism for granted. I said (Nov. 2, 1861), "I have no doubt that when he returned to his studies after the seizure, he imagined that he had tested the whole system of syllogism upon his most

recent definitions of the quantifying words." According to Mr Baynes I have charged Hamilton with false reasoning: the preceding quotations will show the sense in which the charge was made. Be it remembered that these quotations are no afterthoughts, but actual accompaniments of what is called the "charge". But I regret to say that the last proof of my view of the subject, given near the end of this addition as very recently discovered, shakes my confidence in Hamilton's want of examination, though I still hold that it is the more probable hypothesis.

my own explanatory excuse from the preceding paper,—I omit Mr Baynes's defence from this addition. I may hereafter compare it with my own excuse, when something arises which the comparison will illustrate. I also asked (Nov. 2, 1861) for information as to whether Hamilton had given his own sense of 'some' *from his chair*. The silence of all his pupils on this point obliged me to think he might actually have taught this sense of 'some' as to be applied to the only forms of syllogism which I could—or can—ascertain that he had given. I therefore (Oct. 18, 1862) put the question in stronger terms, and by name to Mr Baynes, to Hamilton's editors, and to his successor. In taking up this point, Mr Baynes of course felt it necessary to take up the others; but on this point his answer (Nov. 22, 1862) was explicit and satisfactory; as follows. "Within my experience of his class-teaching (up to the close of session 1853-4), Sir William did not, that I remember, depart from the ordinary meaning of "some" in teaching the syllogism. But for years before this he was accustomed to expound briefly from the chair his doctrine of immediate inference [in which one proposition only is concerned], and of course as a part of it the different meanings of 'some'." This is to the purpose; and Mr Baynes is the best living witness on the matter.

The remaining point is that of the application of the new meaning of "some" to syllogism. On this Mr Baynes speaks—but without a single reference in proof of his statements—as follows: I put some words in Italics (Nov. 22, 1862).

"The alleged invalidity of these syllogisms wholly depends on the use of the quantifying term "some" in a *special sense*. But Prof. De Morgan offers *no proof whatever* that it is so employed in the scheme he criticises. He states, indeed, what is perfectly true, that Sir William Hamilton signalled this particular meaning and *contended for its partial use*. [This statement is not mine.] Sir William Hamilton, in applying his new doctrine to propositional forms, discusses the vague generality of "some" in its ordinary use as a mark of quantity, points out that it may be taken in a narrower or more definite sense, and proposes the introduction of this new meaning "alongside of the other" *in particular cases and for special objects*. These objects, as Sir William defines them, *all* relate to propositional forms. The *partial* use of the narrower "some" not only yields a complete and consistent scheme of opposition, but supplies certain valuable forms of immediate inference. For these reasons, Sir William introduces alongside the ordinary and vaguer "some" (some at least) the more definite "some" (some at most) as a mark of quantity; but *he carefully defines the condition of its use, and specifies the instances in which it is actually employed*. From this *partial and well-defined* use of the more definite "some" in the treatment of propositional forms, Prof. De Morgan *assumes* that Sir William Hamilton not only carries it over into his scheme of syllogism, but applies it to every detail of that scheme."

In my reply (Nov. 29, 1862) I disposed of two of the Italic phrases by pointing out that I had given references to the successive papers on proposition and syllogism, which, writing to persons who had the book in their hands, and power to follow an implied argument in their heads, I took to be quite enough. I challenged Mr Baynes to support the remaining words in Italics from Hamilton's writings, stating that this present paper was going to the printer, and desiring to couple with my statements the fullest account of his answer. Mr Baynes, acknowledging my references by substituting want of "definite proof" for statement that I

had made only "simple assertion", refused (Dec. 6, 1862) to give any support whatever to what he admitted were his own unsupported assertions, until after the appearance of this memoir. He then pledged himself to reply if I should support my case by "definite evidence", by "anything like proof", by "anything indeed approaching to a plausible reason". It would require, he said, "not only a detailed statement, but a number of extracts". I take Mr Baynes as admitting that no single extract, and no two extracts put together, would make a *primâ facie* appearance of contradiction to my hypothesis. I fear I shall never see this defence: the mode of proceeding does not promise much. In Mr Baynes's short opening letter (Nov. 1, 1862), he thinks his reply "may be put into very moderate compass"; and that it "may be easily shown that Prof. De Morgan's chief difficulties arise from a complete, though perhaps not very unnatural, misunderstanding of Sir W. Hamilton's condensed form of expression". Here the words "easily shown" can hardly have meant that all the showing was to be assertion, without one single supporting reference to Hamilton's writings. But when Mr Baynes finds that simple assertion will not be taken as showing anything, and that substantiating references are called for, and when he is told that I shall handle his reply in this paper, the moderate compass becomes detailed statement too long for the journal, and the tone becomes more sarcastic. In pointing this out I direct attention to all¹ that Mr Baynes will allow to be shown: high confidence with good humoured condescension changing, on demand for proof of statements, into what must be interpreted as confession of difficulty, with disparagements and ironies which seem intended to avenge the difficulty upon him who put it in the way. I am quite content that Mr Baynes's imitation of his great teacher's tone of controversy shall continue, provided only that he will demand respectable references from every statement which applies for admission. Should he really attempt to redeem his conditional pledge, I shall be much pleased: for I confidently expect that my views will be positively confirmed. But should I and the public hear nothing more from him, which from his recent retreat is too much to be feared, I must be content with the negative confirmation which his silence will inevitably be taken to afford. But I hope better things.

I now proceed to point out how I came to arrive at so strange a conclusion as that Hamilton's *own new* propositional forms, emerging out of his *own new* use of "some", were intended to be used, as well as the old ones, in his *own new* system of syllogistic forms. In every book of logic the treatment of the proposition precedes that of the syllogism: and the forms of enunciation treated in the chapter on propositions are those used in the chapter on syllogism. This of course; for usually there is but one system of propositions. When, for the first time, we see two systems of propositional forms, of which

¹ Perhaps not quite all. The assertions being dismissed which are to be established "some" day at latest (perhaps therefore never?) there remains the fact proved by Mr Baynes's evidence, that Hamilton explained to his class the doubly partitive "some," and (ix. ii. 268) the *immediate* inference thence arising. There is also the fact proved by Mr Baynes's silence, that Hamilton did not therewith tell his hearers that the doubly partitive enunciations would not validate the only syllogistic forms which he had given them. In my mind this adds probability to the hypothesis that Hamilton had never tested the

point: it was his habit to go on year after year without making any alterations. If he began to explain doubly partitive enunciation to his class, with an intention of soon proceeding to investigate the syllogism belonging to it, there is good reason to suppose that, though the execution of the intention were delayed, he would still continue his imperfect statement. The third Lecture on Logic has pages beginning with "I would interpolate some observations which I ought, in my last Lecture, to have made before leaving....." These lectures were read for twenty years without the alteration being made.

the new one is declared to be placed "alongside" of the old¹ one, we must needs infer—unless the contrary be expressly stated—that both sets of forms are to be used in syllogism. If we be to have a thing so completely unheard of as a set of propositions which have no syllogisms in which they combine, we feel that the writer will certainly give us warning of what we are not to expect: especially when the new system is to stand alongside of the old one, side by side, in the same rank. Hamilton, writing on his own system, left a rough but very elaborate sketch of propositional forms, and another of syllogisms (*Logic*, II. 277—284, 285—289, appendixes (d) and (e)). These are given consecutively² by his editors, without a word indicating that it had passed through their minds that, of the two sets of propositional forms given, the new one was, or might be, unconnected with the one system of syllogism which appears to belong to both, for aught that Hamilton says to the contrary. These volumes are edited, as was said of them in a review, "in the best style of laborious and conscientious workmanship": and they contain much more than a casual reader can appreciate of unpretending reference and comparison. The additional papers, on which this discussion arises, are put together in a manner which makes it clear that the trouble they cost must have left the editors in close possession of their details.

Finding that the new sense of "some" made syllogistic forms invalid, and having searched in vain for anything even congruent with the notion that this new sense was not to be used in syllogism, I publicly applied to Hamilton's followers for information. None was given for a year. The editors³ and Mr Baynes, who was Hamilton's substitute during illness, remained

¹ "Though it may not supersede" the other: not "must not," nor "ought not to;" but only "may not." The phrase is no more than permissive to the old system to remain, if others insist on it. That this was the leaning of Hamilton's mind—nay more, that disapprobation accompanied the permission—is evidenced, I think, throughout his discussion. For instance, by his interpolation quoted in the body of the paper, to his reprint of the letter in the *Athenæum* journal: here he says that "as we shall see, two particulars in the affirmative and negative forms, ought to infer each other". To this it must be added that (IX. II. 254) he, in January 1850, demands it as a *postulate of Logic* that "the *some*, if not otherwise qualified, means *some only*—this by presumption." If we accept Mr Baynes's statement, that *some only* (= *some at most*) was not intended to be introduced into syllogism, and if *some*, without qualification, be to mean *some only*, it follows that there is to be no formal syllogism in which the quantifying word 'some' stands alone. That the old forms can be well spared, is clearly in Hamilton's meaning: and if they go, what have we left? The new forms, without any syllogism?

² It weighed much with me that one of the editors, Mr Mansel (IV. 113) came to his task with the conviction that Hamilton had a use of "some" different from that of Aristotle; and that this new sense of "some" was applied to some sort of syllogism. The quotation given in the body of the paper shows this. When the unpublished papers came into Mr Mansel's hands, he, without any editorial remark, allowed the syllogisms in appendix (e) to follow the new and additional sense of 'some' propounded in appendix (d). I took it that he—who had shown his belief that Hamilton did apply *some* new 'some' to syllogism—had no reason to doubt that the

syllogisms which he presented as editor were those which he had opposed to mine as reviewer. I divided the responsibility between Hamilton and the editors in the following words (*Aug. 17, 1861*)—"I do not say that Hamilton himself would have admitted this syllogism. But I do say that those who will accept his writings as they stand must admit it." Mr Mansel did not impeach either my interpretation of Hamilton, or my implied interpretation of his own editorial proceeding. I consequently became fixed in the belief, which I still hold, that I had construed the editors rightly: and I believe that they were right as well as I. Though they had examined (e), which it was *not* their business to do, with reference to the validity of the connexion, they would not have been justified in deviating from the course they have taken. They might have taken up my suspicion that Hamilton forgot, after his seizure, that he had not finished his investigation. They might have suggested what Mr Baynes asserts, but refuses to prove in time for this paper, that the new propositions were never intended to walk the world in pairs. But, whatever they might have thought, it would have been their duty to put the *new* syllogisms into that connexion with the *new* propositions which the state of the papers seemed to require; leaving their caveat, if they had given one, to work its own effect on the reader's judgment.

³ Mr Mansel, and Professor Fraser, Hamilton's successor, have a right to the statement that they privately, in reply to applications from me, made after my letters were published, informed me that they had no more means of information than were open to myself in print. It was not for me to ask what opinion they had formed from these materials. The reader will understand that the second public application, especially

silent. Another appeal, relating to what Hamilton had orally taught, of a pointed and personal character, brought out Mr Baynes on the whole question, with assertions which are—if he should see any plausibility¹ in my reasoning—to be substantiated so soon as my most appropriate opportunity of discussing them shall have passed away. These things speak for themselves: I fully anticipate that any attempt to invalidate my conclusion will speak more plainly still. Something I have got; I have extracted the defence which is to be set up; namely, that the new sense of “some” is to be *asyllogistic*. Should any one point out to me, publicly or privately, any passage in Hamilton’s writings on his sense of ‘some’ which expresses or implies that this was the case in his mind, or even agrees better with this supposition than with its contradiction, I will discuss that passage when I next take up the subject. In the mean time, I cannot too distinctly affirm that the most attentive consideration² has not enabled me to detect such a passage.

I now come to a proof which I cannot claim as one of my original grounds, for I never noticed it until after this addition had been dated and signed. I can easily understand how I came to miss it. I always read Hamilton’s paper (VI.) in the *Discussions* as his defence of himself: I gave it comparatively little of sharp scrutiny as his attack on me. I recommend to every one who has to read a mixed polemical argument to give separate readings, some treating it solely as attack without reference to defence, some treating it solely as defence without reference to attack. The article (VI.) was written against my *second* paper. In that paper I had no notion³ whatever that Hamilton had any other sense of ‘some’ than that of the logicians; this will be very apparent. I state that *six* of his propositions agree with those of the old school; which is not true of any *one*; I add that the remaining two are “peculiar propositions.” I set out the list of syllogisms symbolically; I point out the differences between Hamilton’s system and my *exemplar* derivation from it; especially the failure of the canon of

made to four persons, was not on a question of opinion, but on a question of fact; namely, as to what sense of “some” Hamilton taught from his chair: this question could be decided only by testimony.

¹ Since the bulk of this addition was written, Mr Baynes (*Dec.* 20) has given an *unconditional* assurance that he will attempt to substantiate his statements. It was drawn out by a letter of mine (*Dec.* 13) in which I administered what I call a rebuke, and he calls a personality, upon the tone of his preceding letter. Here I need only say that I think my remark was richly deserved, and that I know it was meant to be directly personal. I have much reason to be pleased with the result, namely, the withdrawal of the condition which left Mr Baynes at liberty to attempt proof of his statements, or to leave it alone, as should seem fit. I expect good from the discussion, which is really that of the question, argued upon an instance, whether one who is *not* of a mathematical turn can safely attempt to meddle with the forms of logic. My opponents—all at least who follow Hamilton—will hold that the word in *Italics* ought to be omitted; and I readily accept this as the issue, should it please them to take it.

² The latest account which Hamilton gave of the propositions furnished by his own ‘some’ is in the *Discussions* (VI. 631*): to me it is also the clearest. After distinctly relegating the old system, *indefinite definitude*, to subsequent

pages, he proceeds to explain his diagrams, in which parallel straight lines denote coextension so far as they run together, and coexclusion so far as they separate. Letters stand for terms, as usual: D and Δ for coextensives; Z and Ω for total coexclusives; B and C for includent and included; C and K for partially co-including and co-excluding; and something I am not sure I understand for ‘Some—is not some—’. This I must explain to show that he is really symbolizing his own peculiar forms. Then follows “the rationale of the letters is manifest;.....”; it is so, and it is manifest that, so far as the different letters are distinctively symbolic, they typify circumstances peculiar to Hamilton’s own system. The sentence then runs on thus: “and it is likewise manifest, that this principle of notation may be carried out into syllogistic.” Here is an express reference to syllogism in connexion with the new sense of ‘some.’ Any one who denies that the new propositions are meant to be applied to syllogism must rebut, from elsewhere, the presumption which this passage raises.

³ “But Sir William Hamilton is the first who published the idea of taking all phases of usual quantification, and making them the basis of a system of syllogism” (§ 4 of my second paper, Vol. IX. p. 1). The word *usual* implies antithesis, not to any other meaning of ‘some,’ but to the numerical quantification.

inference. Hamilton sees all this (VI. 630*), speaks of my treatment of his syllogism, reprehends me for my alleged mistake about his canon of inference, &c. But what of all this? Hamilton had the old system as well as the new. This is the point. He goes on to show that his head is so full of his own new plan that he cannot read an opponent in any other sense; that he cannot understand an opponent who knows nothing of his 'some at most', which he was then giving *for the first time in print*. He goes on to say (VI. 631*) "I shall first consider the objections [*i. e.* my objections] to the *propositional forms*, which I have peculiarly adopted. But it is proper to premise a general enumeration of these;..." He then proceeds to lay down what I have already called his clearest explanation of the forms involving his new sense of 'some'. Having done this, he proceeds with "Of the four propositional forms specially recognised by me (1, 3, 6, 8) Mr De Morgan questions only two...;" Surely, because I took the other two, as I said, to be converted Aristotelians; but Hamilton clearly supposes that I had taken him in his own peculiar sense throughout. Thus when he comes (VI. 633*) to assail me for compounding "All Xs are all Ys" out of "all Xs are some Ys" and "Some Xs are all Ys" he charges me with compounding "*impossible* propositions": that is, he supposes me to be taking his own propositions in his own sense. He proceeds thus—"But unless *some* be identified with *all* [as it may be in the old system], if either of the latter propositions is true the other must be false;—nay, in fact, if either be true, the very proposition which they are supposed to concur in generating is false likewise." I now see what all this means: it says in effect—"You pretend to argue about *my* propositions and their connexion, while you are advancing objections which are valid only on the supposition that some of *my* forms are the *old ones*."

It would have been absurd in Hamilton to have argued against me that my conjunction required *some* to be identified with *all*, unless he had supposed me to be employing a 'some' which could not be so identified. It stands thus. I was representing Hamilton's system to the best of my knowledge. Hamilton had not, so far as I knew, any but the common meaning of 'some'. But he had another meaning, of which his own head was so full that he took it as of course that in my representation of him I adopted that meaning. He did not object to my collection of syllogistic forms—and they are identical with those on which this discussion has arisen. By failure of objection he accepts these forms, and quarrels with nothing but the form I had given of the canon of inference. If Mr Baynes be correct, Hamilton ought to have told me that his own new use of 'some' was partial; that it is for particular cases and for special objects; that it is only for isolated propositions and *immediate* inference; that I was wrong in assuming it intended for syllogism at all, and still more wrong in carrying it into every detail. Instead of all this, he opens his fire by charging me with having taken the rule of *mediate* inference from Ploucquet, and then proceeds to a detailed exposition of his own new forms, of which he makes me receive six, and object to two. It is now for Mr Baynes to make Hamilton contradict me without making him contradict himself.

There is one point which many persons may misconceive: and on which I therefore notice Mr Baynes again. Wishing to give an account of all the strength of his answer, I reminded him of the difficulty which would exist, a hundred years hence, in confronting the weekly journal with the scientific quarto; and I suggested that he should substantiate certain

assertions in time for me to present his whole case in this addition. In reply¹ he is jocose upon the idea of posterity knowing anything about the matter. He may think, as perhaps many do, that the whole question is about Hamilton and myself; I, from the beginning, in 1847, have never considered it in this light. I believe, and I am joined by many reflecting persons, among students both of logic and of mathematics, that as the increasing number of those who attend to both becomes larger and larger still, a serious discussion will arise upon the connexion of the two great branches of exact science, the study of the necessary laws of thought, the study of the necessary matter of thought. The severance which has been widening ever since physical philosophy discovered how to make mathematics her own especial instrument will be examined, and the history of it will be written. A great contest of that future day will be seen to have had its origin in our day; the details of the controversy which began in 1847 will be sought for as matters of its early history; the questions which have arisen between Hamilton and myself will be renewed between writers who will have a small public versed in both sciences to judge them. Let all else end how it may, it is clear that the great change to which Hamilton's name must be attached, the *expressed* quantification of the predicate, must have its history. To every one of our day his own opinion as to how the questions will be settled, or as to whether they will ever be settled at all: but I find that the reflecting of all sides are prescient of a discussion to come. Among them I doubt not I may place the administrators of our Society for the last twelve years: I cannot in any other way explain the publicity given by them to the controversial parts of this series of papers. While such anticipations exist among so large a number of thinking men, there is no reason to quail before those who joke the jokes which are stereotyped against all who avow that they take posterity into their calculations: there is as good a retort, not quite so commonplace. I have over them this undeniable advantage: if right, I shall be known to have been right; if wrong, I shall not be known to have been wrong.

A. DE MORGAN.

December 26, 1863.

¹ Mr Baynes derives innocent amusement from the words "scientific quarto." It may be worth while to inform those who do not know it that the scientific transactions are, almost without exception, printed in quarto form; while separate works are almost always in octavo. Hence a reference to *quarto* is—in the United Kingdom—rapidly coming to mean allusion to publication in one of the sets of transactions. I have, a hundred times, heard such a phrase as "That is not in his work; that is in the quarto memoir;" meaning that the author had not published in his separate writing something he had previously given in a memoir inserted in the transactions of some scientific body. I fell into the phrase "scientific quarto" as briefer than "transactions of a scientific body." It may be useful to foreigners, who have more separate writings in quarto than ourselves, to notice this growing idiom of our language.

Addition to page 18. From the list of those who lay down nothing but exemplar readings Keckermann must be excluded. His universals are all laid down in the singular (except *cuncti*), and his particulars all in the plural (except *non nemo*). And these are employed, for the most part, in his instances of syllogism; universals in the singular, particulars in the plural. But Ramus may be added to the exemplar list. I also find that *quidam* is not so uniformly excluded as Mr Spalding supposed: Stahl and Keckermann both give it.

Addition to page 43. The restricted readings may be easily connected with the peculiar pairs in page 30, in which *pp* goes with (·),)(; *ww* with)(, (·); *pw* with ((, ·); *wp* with)) , (·. Take the secondary and concluding relation from any case in which restrictions exist; the letters to which they are attached in the last sentence point out the *restricted* readings. Thus)(, (·, giving)(and (·, has *ww* and *wp* for restricted readings:)(·), giving)(, (·, has *pw*, *pp*, restricted.



INDEX TO VOLUME X.

- ABELARD's Dialectice, 152
- Abnormities in voluntary Muscles, 240—247
- Accelerations and velocities with respect to moving axes, 1—20
- radial, transversal, and azimuthal, expressions for, 6
- tangential and in principal normal, expressions for, 7
- Accent, Latin, Mr Munro on laws of, 377; Ritschl on, 382
- Acrostichs, Latin, Mr Munro on, 376
- Æschines, supposed statue of, 233
- Æschylus, Agamemnon, explanation of passages in, 92, 93
- Aggregation and composition, distinction of, 192
- Aggregation, postulates and theorems relating to, 292
- AIRY, G. B., M.A. On the substitution of methods founded on Ordinary Geometry for Methods based on the General Doctrine of Proportions, in the treatment of some Geometrical Problems, 166; Euclid's Doctrine of Proportion the only one perfectly general, *ib.*; but in special cases often cumbersome from its generality, *ib.*; can be avoided when geometrical lines alone are the subject of investigation, *ib.*; by a new treatment of a theorem equivalent to Euclid's simple *ex æquali*, *ib.*; and of doctrine of similar triangles, *ib.*; series of propositions sufficient for this purpose proved, 167—170; their use illustrated by application to a well-known theorem, 171; Addendum. New Proof by Prof. de Morgan of Euclid's Theorem of *ex æquali in ordine perturbata*, 172
- Suggestion of a Proof of the Theorem that every Algebraic Equation has a Root, 283
- Supplement to a Proof of the Theorem that every Algebraic Equation has a Root, 327; objection to Proof (p. 283 et seq.) that it is obtained by the use of imaginary symbols, 327, § 19; the problem divested of the idea of imaginary roots is to shew "that every algebraic expression can be divided without remainder by $x^2 - 2\rho \cos \theta x + \rho^2$," § 20; the actual division by this expression effected and the remainder obtained in the case of an expression of the 8th degree, § 21, 22; the condition of evanescence of the remainder leads to two equations of condition, the possibility of satisfying which has been demonstrated in the former Memoir, § 23, 24; Cotes' Theorem demonstrated by a method indicated, § 26; the method of the Memoir perfectly general, § 27
- Airy's Integral $\int_0^\infty \cos \frac{\pi}{2} (w^2 - mw) dw$, remarks upon, 105; the differential equation to which it leads discussed, and the values of the arbitrary constants determined, 115; its complete integral geometrically illustrated, 116
- Algebra, a branch of thought in which the process is visible, 179
- Alimentary Canal, manifestation of current force during secretions in, 250—252; theoretical remarks on, 251, 252
- Ambiguity, terminal, mathematical view, 199; metaphysical view, 200
- Ameinocles, inventor of Trirème, 84
- Ampère's Laws of Electromagnetism, 55
- Analogies, physical, 28
- Animal Electricity, remarks on, 248
- Antisthenes, criticised in Theætetus, 158, 165; his hatred of Plato, 159; criticised in Philebus, 160
- Argument, on origin and proper use of word, by Dr Donaldson, 317; etymology of, *ib.*; classical and technical uses of the word, 319; used in logic to denote the middle term, 321; three meanings of, 324; ought not to be used for a process of reasoning, 326
- Aristides, supposed statue of, 231
- Aristotle, his allusions to Plato, 147; *De Anima*, Passage in, *ib.*; reference to Politicus, 148; Politics, passage in, *ib.*; method of dichotomy, *ib.*; other allusions to Plato, 149; Posterior Analytics, 162
- Aristotle's system of logic, *exemplar*, 443; misconceived by recent writers, *ib.*
- Aristophanes, Equites, explanation of passage, 92
- Arithmetical whole, in logic, 190, 194, 209, 212
- 'Arnold on Homer,' Munro on, 403

- Arrows, velocity of, 370; range of, 373
- Athenæus, comic fragment preserved by, 161
- Atom, meaning of, as applied to a proposed division of octave, 130
- ἄρακτος, explanation of, 308
- Attraction, formulæ of, analogy between, and those of heat, 28
- Attribution, unity of, discarded in favour of plurality of qualification, 185
- Average, of k^{th} power of sum of values, theorem relating to, 412; not merely the mean value but also the mean supposition as to the mode of obtaining value, 416
- Axes, moving, theory of, 1—20
- BAXTER, H. F., M.R.C.S.L. On Organic Polarity, 248; reasons for choice of this title, *ib.*; history of previous researches, 248, 249; subject of the paper, *The Manifestation of Current Force during the processes of Secretion*: (i) during the formation of the secretions in the mucous membrane of stomach and intestines, 250—252; Wollaston's conjectures and experiments on this subject, 253; (ii) during biliary secretion, 254; (iii) during urinary secretion, 255, 256; (iv) during mammary secretion, 257; (v) during respiration, 257, 258; concluding remarks (containing reference to Graham's researches on *Osmose*), 258—260
- Baynes, T. Spencer, Essay on the new Analytic, 448; and Hamilton's system, 481
- Beams, motion of, under passing load, 360
- Beats of imperfect consonances, on the, 129—145; history of theory of, 129—135; Dr Smith's theory and his formulæ deduced, 135—141
- of two kinds, Tartini's and Smith's, 131, 132; Tartini's used by Sauveur, 131; the two kinds confounded by Young, Chladni, and probably by Robison, 133—135
- Biliary secretion, manifestation of current force during, 254, 255
- Blakesley, on his copy of an inscription, by Mr Munro, 374
- Bow, motion of vibrating, 359; power of steel, 373
- Breadth and Depth, use of, by Sir W. Hamilton, 225 note, 229
- Butler, Professor Archer, on History of Ancient Philosophy, 94; statement of Platonic philosophy, 95
- Cauchy's theorem on the limits of imaginary roots demonstrated, with an extension thereof, 265, 266
- Charges of propositions and syllogisms in ordinary use, 181
- Charts, Mercator's and Gnomonic Projection, 272; for great circle sailing, construction of, 278; use of same, 279; examples, 280
- Chest, deformity in, will not arise from the defect or absence of the pectoral and serrati muscles if the skeleton be sound, 246
- Chladni, his confusion of Tartini's beats with Smith's, 134, 135; disputed the claim of Tartini to the discovery of the *grave harmonic*, 132 *n.*
- Circles, theorem concerning tangents to each pair of three unequal, proved, 171
- Cirta, metrical inscription at, 374
- Coil-machine, spherical electromagnetic, theory of, 79, 80
- Commodian, his poems, Mr Munro on, 376
- Concert-pitch, cause of ascent of, considered, 131
- Conduction of current electricity, theory of, 46
- equations of, 39; reference to memoirs by Stokes and Thomson, 40
- Conservation of momentum, principle of, 9, § 16
- Continuity, ordinal, illustrated, 24
- of value and permanence of form, distinction between, 22
- Copula, of cause and effect, 179; other than "is" needed, 193
- Core of electromagnet, effect of, 77, 78
- Correlatives, right of all in any set to equal fulness of treatment, 452
- Cotes' theorem, a demonstration of, indicated, 329, § 26
- Current force, manifestation of, during secretion, 248. See Baxter, H. F. on Organic Polarity
- Currents, electric, action of, at a distance, 48; produced by induction, 50
- Curves, course and latitude, construction of, 282
- De Moivre's Doctrine of Chances, appearance of e^{-x^2} in, 418
- DE MORGAN, A. on the Beats of Imperfect Consonances, 129—141; History of the theory of Beats, 129—135; Theory of Beats of Imperfect Consonances, 135—141; observations on tuning and on temperament (Postscript), 141—145; Dr Robert Smith's work on Harmonics, 129; two kinds of beats, Tartini's beats and Smith's beats, 131, 132; unfavourable opinion of Young on Smith's theory shewn to result from confusing Tartini's beats with Smith's, 133, 134; the same mistake made by Chladni, and, probably, by Robison, 134, 135; Tartini's beats used by Sauveur, 131; and Smith's accusation that Sauveur confounded the beats of an imperfect consonance with the flutterings of a perfect one shewn to be not true, 132, 133; on the division of the octave and on musical intervals, 129—131; new division proposed, and a new term *atom* defined, 130; various problems solved, as on the number of mean semitones in a number of *atoms*, &c. *ib.*; Tartini's *grave harmonic*, 131; Tartini's beats considered in connexion with Smith's, 135—137; formulæ obtained, 138; Smith's formulæ deduced therefrom, 139
- On the general principles of which the composition or aggregation of forces is a consequence, 290; tendency defined, 291; four postulates stated as the

grounds of every method of aggregation known in mechanics and five theorems following from them, 292; whence the laws of aggregation of forces either meeting in a point, 293, or parallel, are deduced, 294; applications to translations, 296; and rotations, 297; velocity of ditto, 298; statical pressure, 299; dynamical pressure, 302

DE MORGAN, A. On the question, what is the solution of a Differential Equation? A supplement to the third section of a paper, on some points of the Integral Calculus, printed in Vol. IX. Part II., 21—26. The object of the paper is to shew that common theorems about the singularity of the constant of integration must be transferred from differential *equations* to differential *relations*, 22; correction which the common theory requires, 25; Differential Equation, what is meant by solution of, 21—26

— A proof of the Existence of a Root in every Algebraic Equation: with an examination and extension of Cauchy's Theorem on Imaginary Roots and Remarks on the Proofs of the existence of Roots given by Argand and by Mourey, 261; prefix to Sturm's demonstration of Cauchy's theorem on the limits of imaginary roots which establishes the existence of roots, 261—263; algebraical substitute for a geometrical step in Sturm's proof, 264, 265; Cauchy's theorem with an extension thereof, 265, 266; Argand's Proof of the existence of Roots, 267; Mourey's proof, 268, 269; postscript on divergent series and spherical triangles, 269, 270

— New Proof of Euclid's proposition *ex æquali in ordine perturbato*, 166, 172

— On the Syllogism No. III., and on Logic in general, 173; modern definition of logic relates to a distinction more familiar to mathematicians than logicians, 175; logic both science and art, 181; *charges* of propositions and syllogisms, *ib.*; objections to use of mathematical symbols in, discussed, 183; the only science which has grown no symbols, 184; hitherto confined to logico-mathematical field but to be extended to the metaphysical field, 184; extension and intension claimed for both the mathematical and metaphysical sides of, and symbolised, 184; distinction of extension and comprehension misconceived by recent logicians, 187; *onymatic* relations, 190; fourfold mode of thought, denoted and symbolised, *ib.*; arithmetical whole in logic, 190—194; form, quality and quantity of propositions, 194; use of *force* to express quantity in metaphysical reading, 197; schetical system, 199; spicular notation, 198; mathematical and metaphysical views of terminal ambiguity and precision, 200; first elements of a system of logic, 206

— On the syllogism No. IV., and the logic of Relations, 331; influence of the schoolmen on language, 332; difficulties in applying laws of thought to un-

familiar matter, 334; logic not to be confined to the onymatic form, 335; no purely formal proposition except this, 'there is the probability a that X is in the relation Z to Y ,' 339; necessity of taking account of combinations involving a sign of inherent quantity, 341; table of forms of syllogism, 350; extension to quantified propositions, 352; cases of convertible and transitive relations, 353; technical exhibition of the syllogism not necessary in reasoning, 356; syllogisms of transposed quantity, *355

— On Syllogism No. V., and on various points of the Onymatic system, 428; criticism of Hamilton's system, *ib.*; explanation of Aristotle's system, 442; which is affirmed to be *exemplar*, 443; and misconceived by recent writers, *ib.*; right of both correlatives in any pair, and of all in any set to equal fulness of treatment, 452; application to the distinction of affirmation, and non-affirmation, *ib.*; syllogism of indecision, 453; eight onymatic forms deduced from purely onymatic meaning, 455; alleged demonstration of the necessity and completeness of these forms, *ib.*; restrictive propositions, their affirmation and denial introduced in every view except the purely onymatic whenever complete treatment of all correlatives is allowed, 456; completion of exemplar system, 457; extended comparison of the onymatic relations, 459; system of primary and secondary relations by copula of identification, 463; the same when the copula is any one of the simple onymatic relations, 469; the full system at which the Hamiltonian quantification aims, 471; logical basis of extension and comprehension, 475; addition on a recent phase of the controversy, Dec. 1862, 481

— On the Theory of Errors of Observation, 409; probability and facility contrasted, *ib.*; difficulty of passing in argument from the finite to the infinite or infinite to finite, 410; theorem that "all values being positive and the number of letters taking value being infinite, the average of the k^{th} powers of the sum of values is the k^{th} power of the sum of average values," 412; laws of facility of value discussed, 413; deficiency in Laplace's investigation, 415; first principles, number of observations finite, 416; average defined, *ib.*; law of error deduced from observations, 418; mode of deducing probable results, 421; difficulties in probability corresponding to indivisibles in geometry, 424; process of solving them, *ib.*; origin of fluxional notion, 426

Demosthenes, Statue of Solon mentioned by, 231, 235

Dialectic, Platonic, 152; Aristotelian, *ib.*; of Schoolmen, *ib.*

Diamagnetic Induction, Theory of, 44

Diamagnetic or Paramagnetic Sphere, effect of, in a uniform magnetic field, 70, 71; case when the field is the terrestrial magnetic field, 71

Dielectrics, Theory of, 43

- Differential Equation $\frac{d^2u}{dx^2} + \frac{1}{x} \frac{du}{dx} - u = 0$ discussed, 121; the complete integral according to ascending series given, 122; the same integral also expressed by descending series, *ib.*; the relation between the constants in these two integrals determined, 123; the discontinuity of the arbitrary constants determined, 122
- Divisive Method, invention of, attributed to Plato, 162
- DONALDSON, Dr J. W. On the origin and proper use of the word Argument, 317; etymology of Argument, *ib.*; borne out by the classical usage and technical application of the word, 319; the proper use of the word in logic to denote the middle term, 321; Aristotelian *enthymeme* may be rendered approximately by *argument*, 322; how *argument* and *topic* came to denote the subject of a discourse, 324; three meanings of argument in English writers, (1) Proof, (2) process of reasoning, (3) subject of discourse proved by examples, 325; the second use ought to be excluded from scientific language, 326
- On Plato's Cosmical system, 305; translation of passage in Republic, *ib.*; examination of points in Greek text of same, 307; explanation of meaning of same, 310
- On the Statue of Solon mentioned by Æschines and Demosthenes, 231; a statue in *Museo Borbonico* supposed to represent Aristides the Just, *ib.*; or Ælius Aristides, 232; or Æschines, 233; these theories refuted, *ib.*; shewn to be that of Solon, 235
- On the structure of the Athenian Trireme, 84
- Dynamics of material system, with application to motion of body of invariable form, 7—20
- Dynamics and Statics, their relation to each other, 11 n.
- Eandi, Vassali, Letter from M. Delaméthrie (*Journal de Physique*, 1799), 256; his experiments in support of existence of animal electricity, *ib.*
- Elastic rod, motion of, fixed at one end, 365; bent within breaking limit may be broken by rebound on being set free, 369
- Eleatic, doctrine, 97; dialogue, the Parmenides an, 100, &c.; Stranger, 154; school, *ib.*; logic, confusion at root of, 155; ontology, nothingness of, 156
- Electric Currents, on Quantity and Intensity as Properties of, 52—54
- Electrical science, present state of the theory and requirements of, 27; the true method of investigation, *ib.*
- Electrical and Magnetic problems with reference to spheres, 68—83; I. Theory of Electrical Images, 68—70; II. On the effect of a paramagnetic or diamagnetic sphere in a uniform field of magnetic force, 70, 71; III. Magnetic field of variable intensity, 71, 72; IV. Two spheres in uniform field, 73; V. Two spheres between the poles of a Magnet, 73, 74; VI. On the Magnetic Phenomena of a Sphere cut from a substance whose coefficient of resistance is different in different directions, 74—76; VII. Permanent magnetism in a spherical shell, 76; VIII. Electromagnetic spherical shell, 77; IX. Effect of the core of the electromagnet, 77, 78; X. Electrotonic functions in spherical electromagnet, 78, 79; XI. Spherical electromagnetic Coil-Machine, 79, 80; XII. Spherical shell revolving in magnetic field, 81
- Electricity, current, conduction of, 46
- Electrodynamics, Weber's physical theory of, stated, 66, 67
- Electromagnet, effect of core of, 77, 78
- Electromagnetism, 55—57; Ampère's laws of, 55
- Electromagnetic, spherical, coil-machine, theory of, 79, 80
- Electromotive forces, 46
- Electrotonic functions, or components of the Electrotonic intensity, 63
- Electrotonic intensity round a curve, 65
- Electrotonic state, meaning of, explained, 51, 52; of Faraday, discussion of, 51—67
- Electrotonic state, conditions of conduction of currents within the medium during changes in, 64; summary of theory of, 65—67
- Emerson, account of his connexion with the theory of beats and the formula which he obtained, 135 and note
- Enthymeme, instances of use of term, 321
- Equation, Differential, meaning of solution of, 21—26
- $dy^2 - a^2 dx^2 = 0$, Euler's solution of, viz. $(y - ax + b)(y + ax + c) = 0$, with opinions of Lacroix and Cauchy thereon, 21; the assertion that the *generality* of Euler's solution is not restricted by the supposition $b = c$ examined, 24
- Equation and Relation, proper meaning of terms, 21
- Equation of conduction, 39
- Equation, proof of theorem, that every algebraic equation has a root, 283, 327
- Er the Pamphylian, 305; same as Zoroaster, 313
- Errors of observation, theory of, 409; deficiency of Laplace's investigation, 415; first principles of, 416; law of, deduced, 418
- Euclid, Sixth Book, Props. II—XIII, can be proved in a different manner, 171; which is of general application to a number of Theorems involving proportions of straight lines (*not areas, &c.*), *ib.*
- Euler's equations of rotation obtained, 14
- Euripides, Hercul., explanation of passage in, 93
- Ex æquali*, new treatment, equivalent to Euclid's theorem of, 167, 168
- *in ordine perturbatâ*, new proof of theorem of, by Prof. De Morgan, 172

- Exemplar*, and *cumular* reading, 212; Aristotle's system affirmed to be, 443; system completed, 457
- Extension and comprehension, distinction of, how made by Aristotle, 187; misconceived by recent logicians, 188; logical basis of, 475
- Extension and intension claimed for both the mathematical and metaphysical sides of logic, and symbolised, 184; former predominates in the mathematical whole, 191; latter in metaphysical, 192
- Facility, contrasted with probability, 409; modulus of, 413, 418; of value, laws of, discussed, 414
- Faraday's lines of Force, 27
- Experimental Researches, the mathematical foundation of the modes of thought in, expressed in six laws, 65, 66
- Electrotonic state, 51
- researches on the *origin* of the power in voltaic circle suggest certain researches on animal secretions, 249
- Field, Magnetic, of uniform or variable Intensity, on effect of sphere placed in, 70—76; revolving spherical shell in, 81—83
- Finite to infinite, difficulty of arguing from, 410
- Fluid, Incompressible, Theory of Motion of, 30—33
- Fluxion, notion of, included in intension and remission of schoolmen, 426
- Force, Intensity of, Method of representing by velocity of an imaginary incompressible fluid in fine tubes of variable section, 30
- lines of, defined, 29
- Forces, laws of aggregation of, 293; proofs of parallelogram of, not mere mathematical playthings, 301
- Force, to express quantity in metaphysical reading, 197
- Form and matter, distinction of, 174; misconceived by recent writers, 177
- Foucault's experiment on heat produced in spherical shell revolving in magnetic field, referred to, 83
- Fraser's Magazine*, criticism of an Article in, by Mr Munro, 403
- Fresnel's Integrals $\int_0^a \cos\left(\frac{\pi}{2} s^2\right) ds$, &c.; also integral $\int_0^i e^{-t^2} dt$ are connected with the integral $\int_a^{\infty} e^{-a^2} da$, 112
- Functions, Electrotonic, defined, 63; in spherical electro-magnet, 78
- $\gamma\gamma\gamma\epsilon\iota\varsigma$ (of Sophista), on, 165
- GODFRAY, H., M.A. On a chart and diagram for facilitating great circle sailing, 271; proposal for chart on Central or Gnomonic projection, 272; on windward sailing, 273; on composite sailing, 277; on construction of the chart, 278; description of course and distance diagram, 279, on use of same, *ib.*, examples of use, 280; on construction of course and latitude curves, 282
- Graham, researches of, on *Ormos* considered, 259
- Grave Harmonic of Tartini, 131
- Gyroscope, Theory of, 18—20
- Hamilton's, Sir W., criticism on De Morgan's logic answered, 223, 229; his system criticised, 429; forms expressed in Aristotelian forms, 434; quantification, full system at which it aims, 471
- Harmonics, Dr Smith on, 129
- HAYWARD, R. B., M.A. On a direct Method of estimating velocities, accelerations and all similar quantities with respect to axes moveable in any manner in space, with applications. The Method with some Kinematical applications, Section I. pages 2—7; Dynamical applications, Sect. II. 7—20
- Heat, formulæ of, analogy between, and those of attraction, 28
- Helmholtz, Method of, in Memoir on Conservation of Force, applied to conditions of conduction of currents within the medium during changes in the electrotonic state, 64
- Hexameter, Latin, Mr Munro on, 387; English, the same on, 403
- Holder, Dr W. His claim to be considered the immediate predecessor of Sauveur in the theory of beats, 131 *n.*
- Iambic, Latin, Mr Munro on, 383
- Ideas, Platonic Theory of, 94
- Images, Electrical, Theory of Sir W. Thomson's, 68—70
- Imaginary symbols, use of, not strictly logical, 327
- Indivisibles, 424
- Induction, Paramagnetic and Diamagnetic, Theory of, 44
- Magnecrystallic, Theory of, 45
- Inductive capacity, 54
- Inertia, measure of, 12; relatively to translation is mass, and to rotation a *quaternion*, in Sir W. Hamilton's sense, *ib.*
- Inscription at Cirta copied by Mr Blakesley, Mr Munro on an, 374; another copy of same, 403
- Integral, Airy's, 105, 115; mode of discontinuity of constants in, determined and discussed, 117; Geometrical illustrations, 118; the complete integral expressed, 119; two different forms of the integral, 116; the two linear relations which connect the two constants in these different forms determined, 119—121
- Integrals, Fresnel's, 112
- Integral $\int_0^{\infty} e^{-a^2} \sin 2ax dx$ considered, 106; determination of the arbitrary constant of this integral and its mode of discontinuity ascertained, 107; the constant determined by a second method confirmatory of previous results, 109

- Intervals, Musical, Theory of, 130, 131; various problems on, 130; application of logarithms to, 130 and note; Woolhouse's essay on, referred to, 135
- Invariable system, motion of, investigated, 11—18
- Kinematical problems, 5—7; *a.* Relative velocities of a point in motion with respect to revolving axes, 5; *b.* Accelerations, radial, transversal in the vertical plane, and perpendicular to that plane, 6; *c.* Accelerations parallel to the tangent, principal normal, and normal to osculating plane of any curve, 7
- Language, influence of schoolmen on, 332
- Lines (straight), properties of, investigated by means of a series of propositions, 167—170; which involve a new treatment of Euclid's Theorem of the simple *ex æquali*, 166, and are proved by Elementary Geometry, *ib.*
- Lines of Force defined, 29
- Logic. See De Morgan.
- Milton's, 181 *n.*; Ramus', *ib.*; Sanderson's, 227; Port Royal, 188—228; Watts', 228; Hospinian's, 229
- general considerations, 173; Aristotle's logic only a beginning, 174
- not to be confined to the onymatic form, 335; of Relation, 331
- Logicians, the first were also mathematicians, 175
- Logico-mathematical, logico-physical, logico-metaphysical, and logico-contraphysical modes of thought symbolised, 190, 210
- Magnecrystalline Induction, Theory of, 45
- Magnetic Field, Uniform or Variable, considered, 70—76
- Quantity and Intensity, 54
- Magnets, theory of action of, on magnetic or diamagnetic spheres considered and explained, 70—76
- Permanent, Theory of, 44
- Mammary Secretion, Manifestation of Current Force during, 257
- Material, some objections arising from its introduction into logic considered, 177
- Material System, on Motion of, 7—10
- MAXWELL, J. CLERK. On Faraday's Lines of Force, Preliminary explanations, 27—30; I. Theory of the Motion of an Incompressible Fluid, 30—33, § 1—9; II. Theory of the uniform motion of an imponderable incompressible fluid through a resisting medium, 33—42, § 10—33; Application of the Idea of Lines of Force, 42, 43; Theory of Dielectrics, 43, 44; Theory of Permanent Magnets, 44; Theory of Paramagnetic and Diamagnetic Induction, 45; Theory of Magnecrystalline Induction, 45, 46; Theory of the conduction of Current Electricity, 46; on Electromotive Forces, 46—48; on the Action of Closed Currents at a Distance, 48—50; on Electric Currents produced by Induction, 50, 51; Part II. on Faraday's "Electrotonic State," 51; on Quantity and Intensity as Properties of Electric Currents, 52—54; Magnetic Quantity and Intensity, 54; Electromagnetism, 55; Analytical Theorems, 57—62; bearing of the foregoing theorems on the theory of magnetism, 62; Summary of the Theory of the Electrotonic State, 65—67; Electrical and Magnetic Problems with reference to spheres, 68—83
- Mode of thought, four-fold, how denoted and symbolised, 190
- Momentum, 7 § 10; Conservation of, 9 § 16
- Momenta, linear and angular, defined, 8 § 11
- Motion of beams and elastic rods, 359
- Moving Axes, theory of, 1—20
- MUNRO, H. A. J., M.A. On a metrical Latin Inscription at Circa, 374; instances of Latin acrostichs, 376; Commodian's poems, *ib.*; on rules of Latin accent, 377; on the Saturnian, hexameter and iambic verses, 383; discussion of the inscription, 397; Appendix, 403; criticism on an article in *Fraser's Magazine*, *ib.*; on the English Hexameter, *ib.*
- Muscles, voluntary, remarkable abnormalities in, 240—247; varieties in, most frequent in parts the office of which is different in different animals, 245; cases exemplifying *primary* defects in, 240, 247
- Musical Intervals, 129, 130; measured by *ratio*, not by *difference*, 129
- Names, uses of, 185; various to one relation, 201; four applications of, 206; formed from other names by intension, extension, and combination, 207
- Nautical Magazine, on windward sailing, 274
- Notation, spicular, in logic, extension of, 198
- Observation, theory of errors of, 409; Deficiency in Laplace's investigation of, 415; first principles of, 416
- Octave, on the division of, 129, 130; new division of, proposed, 130
- Onymatic relations, 190, 209
- logic not to be confined to, 335; extended comparison of, 459; system, 428; forms, deduced from purely onymatic meaning, 455, and demonstrated to be necessary and complete, *ib.*
- Organic Force, a Polar Force, 248, 260
- Polarity, 248; History of certain researches on, 248, 249
- Osculating plane, acceleration normal to, shewn to vanish, 7.
- Osmostic phenomena of secretion compared with, 259; Graham's researches considered, *ib.*
- PAGET, G. E., M.D. Instances of Remarkable Abnormalities in the voluntary Muscles, 240—247; description of two cases of, in brothers, 240—243; the abnormalities in these cases of two opposite kinds, characterised by defect and excess of muscular development, 243;

- the former congenital, the latter probably had their origin after birth and were a consequence of the former, 243, 244; cases, which present some of the same features, mentioned by Messrs Quain, Poland, and James Paget, 244, 245; all these cases illustrate the fact that varieties in muscles are most frequent in parts the office of which is different in different animals, 245; they probably exemplify also *primary* defects in muscles, *ib.*; another case communicated by Mr James Paget, 246; no deformity of the chest existed in any of the cases; hence chest deformity, as in chicken-breast, will not ensue *if the skeleton be sound*, though the Pectoral and Serrati muscles be wholly wanting, 246; Pathology of the cases shortly considered, 246, 247
- Paramagnetic or Diamagnetic sphere, effect of, in a uniform magnetic field, 70, 71; case when the uniform field is that due to terrestrial magnetism, 71
— Induction, theory of, 44
- Parmenides* (Plato), account of, 97, probably not a Platonic dialogue, 100; not referred to by Cicero or Aristotle, 104; referred to by Athenæus, 104; School and theories of, 154; confusion in root of Eleatic logic, 155
- Penteconter, 85
- Periodic Series, Theory of, referred to, and certain results on the discontinuity of arbitrary constants compared therewith, 112
- Permanence of Form and continuity of value, distinction between, 22
- Phædrus*, method of Division in, 163
- Philebus*, treatment of Cynical ethics in, 160
- Pitch (concert), cause of ascent of, considered, 131
- Plato, Cosmical System of, by Dr Donaldson, 305; his theory of sacred numbers, 310; source of his materials, 313
— his theory of Ideas, 94; Sophista and Politicus, on the genuineness of, 146; alluded to by Aristotle, 147, &c.; *Theætetus*, connected with Sophista, 151; *Gigantomachy*, 157; Inventor of Divisive Method, 162; *Phædrus*, 163
- Poinsot's "couple d'impulsion," same in meaning as *angular momentum*, 14 n.; his *Théorie de la Rotation* referred to, 18
- Polar Force, reasons for considering Organic Force as such, 248, 260
- Polarity, organic, 248; history of certain researches on, 248, 249
- Politicus* (Plato), genuineness of, 146; reference to, by Aristotle, 148; quotation from, 160
- Præcilius*, an inscription by, Mr Munro on, 375
- Precision, *terminal*, 200; relation of the two, 213
- Pressure, Statical, laws of, 299; Dynamical ditto, 302
- Principal Axes, the only permanent axes of rotation of a body acted on by no forces, 13, § 24
- Principles, general, of which the composition of forces is a consequence, 290
- Probable results, mode of deducing from observations, 421
- Probability, contrasted with facility, 409; case of in an infinite number of events, 410; negative, 420, 421 n.; indivisible of, 424
- Proof, considerations on, 214
- Proportion, Euclid's Doctrine of, referred to, 166; unnecessarily general in certain special cases, *ib.*; as in the investigation of properties of geometrical lines, *ib.*
- Proposition, form, quality and quantity of, 194, 208; affirmative and negative, 214; universal, 215; restrictive, introduced whenever complete treatment of cor-relatives is allowed, 456
- Propositions, series of Geometrical, 167—170; and application to a well-known Theorem, 171
- Prout, views of, on Secretion, 248
- Quantity of no fundamental account when inclusion and exclusion are opposed to one another and combined with assertion and denial, 195; of extension and intension, how expressed, 197; attachment to mathematical view of, 204
- Rameau, account of, 132 n.; relation of his views on Harmonics to those of Tartini, *ib.*
- Relation, in logic, defined, 208; onymatic, 190, 209; logic of, 331; convertible and transitive, 353; system of primary and secondary, by copula of identification, 463; and when the copula is any one of the simple onymatic relations, 469
- Relation and Equation, proper meaning of terms, 21
- Republic* (Plato), translation of passage in, 305; discussion of points in same passage, 507
- Resisting Medium, theory of uniform motion of an imponderable incompressible fluid through, 33—42
- Respiration, Manifestation of current Force during, 257, 258
- Rhumb, sailing on a, advantages and disadvantages of, 271
- Rhythm, Greek and Latin, Mr Munro on, 383
- Rigid body, meaning of term, 11 n.
- Ritschl on Latin Accent, 382
- RÖHRS, J. H., M.A. On the Motion of Beams and thin Elastic Rods, 359; the original object of the investigation to determine the motion of a vibrating bow, *ib.*; this problem closely connected with that of the vibration of a Railway Girder under the action of a passing load, investigated by Professor Stokes, *ib.*; the latter problem easily solved by the aid of Fourier's Functions when the deflection of the girder is very slight and the pressure of the load constant, 360—363; method of solution indicated when pressure varies,

- 364; and applied to determine deflection of a girder suddenly loaded in the middle, 364, 365; to determine the motion of an elastic rod fixed at one end and free at the other, 365—370; Fourier's functions do not apply to this case, 365; a bent rod within the breaking limit at the centre may be broken by the rebound after it is set free, 369; to determine the velocity of an arrow discharged from a bow, 370—372; the amount of displacement of the centre of the cord assumed to be four times that of the ends and to be constant during the motion, 370; any two bows of same material and of similar figure will impart the same maximum velocity to an arrow, provided the arrows and cords are also similar and proportional, 372; experiments on the range of the "bolts" and the general power of the steel cross-bow, 373
- Root, proof of theorem that every Algebraic equation has a, 283, 327
- Roots of equations, Argand's proof of existence of, 267; Mourey's proof, 268, 269
- Rotation of a body about its centre of gravity, solution of problem of, 14—17; case when no forces act, 17
- Rotations, laws of, 297
- Sailing, great circle, 271; difficulties attending, *ib.*; windward sailing, 273; composite sailing, 277
- Sauveur, the beats commonly called after Tartini, in reality used by. Smith's accusation against, unfounded, 132, 133
- Schematic words needed, 193; system of, 199
- Secretion, Manifestation of Current Force during. See Baxter, H. F., on Organic Polarity, 248
- Secretion, phenomena of, compared with *Osmose*, 259 *σελεις*, 91, 92
- Series *divergent*, property of, 269
- Shakespeare, his use of the word argument, 324; versification of, 387
- Ships, different forms of, Greek, 85
- Simplicius, on Plato's definition of *φαντασία*, 147
- Smith, Dr Robert. His work on Harmonics, 129; beats of, 132; his formulæ deduced in an independent manner, 139; his accusation against Sauveur unfounded, 132, 133
- Socrates, in the Parmenides, 97, &c.; his exposition of tenets of Ephesian followers of Heraclitus, 158
- Solon, statue of, 231; an elegiac poet, 237
- Solution of equation, what requirements as to continuity are conveyed in the term, 23
- Some and all*, use of, in Hamilton's system, 433
- Sophista* (Plato), on the genuineness of, 146; a critique of the doctrines of three other schools, 147; arguments in favour of genuineness, *ib.*; continuation of Theætetus, 151; connexion with, 152; 'earthborn' of, 165
- Spheres, electrical and magnetic, problems with reference to, 68—83
- Spherical shell, permanent magnetism in, 76; effect of filling up the shell with magnetic or diamagnetic matter, *ib.*; electromagnetic, 77; revolution in a uniform magnetic field, 81
- Spherical Triangles, classification of species of, as to character of sides and angles with respect to a right angle, 269, 270
- Spicular notation in logic, 198
- Statics and Dynamics, their relation to each other, 11 *n.*
- Stokes, G. G., M.A., D.C.L. On the discontinuity of Arbitrary Constants which appear in divergent developments, 104; principles of the investigation discussed, § 1—13
- Sturm's proof of Cauchy's theorem on imaginary roots, algebraical substitute for a geometrical step in, 264, 265; proposed prefix to, 261—263
- Σύμμιξις*, a Platonic word, 147
- Συμπλοκή*, an Aristotelian not Platonic word, 147
- Supercontrary distinguished from contrary, 201
- Syllogisms, complicated by *charges*, 181; defined, 217; strengthened, *ib.*; opponent, 218; relations of forms of, *ib.*
- Syllogism, No. III., 173
- Syllogism, No. IV., 331; table of forms of, 350; extension of, to quantified propositions, 352; technical exhibition of, not necessary in reasoning, 356; of transposed quantity, *355
- No. V., 429; of indecision, 453
- Symbols, mathematical, use of, in logic, 183; logic the only science which has grown none, 184
- System, cosmical of Plato, by Dr Donaldson, 305; source of materials for, 313
- Tangents, theorem concerning pairs of, drawn to three unequal circles proved, 171
- Tartini, account of, 132 *n.*; D'Alembert's opinion of his treatise on harmony, *ib.*; beats of (so-called), 132; in reality due to Sauveur, 131; his *grave harmonic*, 131; his beats considered in connexion with Smith's, 135—137
- Temperament and tuning, observations on, 141—145
- Tendency, defined, 291; postulates relating to, 292
- Thalamitæ, 88
- Theætetus* (Plato), 151; connexion with Sophista, 152; materialists described in, 158
- Theorems, Analytical, connected with magnetism, 57—62
- THOMPSON, Prof. On the genuineness of the Sophista of Plato, 146; arguments in favour of genuineness, 147; defence of Politicus against Dr Whewell, 150; explanation of connexion between Sophista and Theætetus, 152; on Eleatic Ontology, 155; on the two sects in the Gigantomachy, 157; on remarks of Dr Whewell's, 163; on the *γηγενείς* of Sophista, 165

- Thomson's (Sir W.), electrical images, theory of, 68—70
 — Papers by, on electricity and magnetism, referred to, 58, 60, 67, 68, 70, 73, 76
- Thranitæ, 89
- Translations of a point, laws of, 296; velocities of, 298
- Triangles, similar, new treatment of doctrine of, 169
- Trireme (Athenian), Dr Donaldson on, 84; rowers of, 85, 87; their arrangement, 85, 86; explanation of difficulties in Tragedians, 92, 93.
- Tuning and temperament, observations on, 141—145
- Universe of a proposition, limitation of, contended for, 190
- Ἐπιζώματα, explanation of word, 307
- Urinary secretion, manifestation of current force during, 255, 256
- Velocities of a point with respect to revolving axes, 5, 6
- Velocities and accelerations with respect to moving axes, 1—20
- Weber's physical theory of electrodynamics, assumptions of, stated and discussed, 66, 67
- WHEWELL, W., D.D. On the Platonic Theory of Ideas, 94; two primary parts of theory, 97; the Parmenides, an Eleatic dialogue, 100; on Sophista and Politicus of Plato, 146, 150; on method of division in Phædrus, 163
- Whole, arithmetical, in logic, 190, 194, 209, 212; probable, not composed entirely of probable parts, 411
- Wholes, three logical, 209
- Wollaston, views of, on animal secretions, 248, 253; his paper (*Phil. Mag.* Vol. xxxiii. p. 488) quoted, 253; his conclusion that secretion is the effect of a power similar to that which exists in a voltaic circle, *ib.*
- Woolhouse, his *Essay on Musical Intervals*, referred to, 135
- Xenophanes, founder of Eleatic school, 154
- Young, Dr Thomas, unfavourable opinion of, on Smith's work on Harmonics, 133, 134; his opinion shewn to be unfounded, owing to his having confused Tartini's beats with Smith's, 133, 134
- Zeno in the Parmenides, 97, sqq.
- Zoroaster, same as Er the Pamphylian, 313
- Zygitæ, 87.









