

Historic, archived document

Do not assume content reflects current scientific knowledge, policies, or practices.





BULLETIN OF THE U.S. DEPARTMENT OF AGRICULTURE



No. 129

Contribution from the Forest Service, Henry S. Graves, Forester.
September 10, 1914.

(PROFESSIONAL PAPER.)

YIELDS FROM THE DESTRUCTIVE DISTILLATION OF CERTAIN HARDWOODS.¹

By L. F. HAWLEY and R. C. PALMER, *Chemists in Forest Products.*

PURPOSE OF EXPERIMENTS.

The chief hardwoods used in this country for distillation are beech, birch, and maple. Only mill and forest waste and trees unmerchantable for lumber are now ordinarily used, although some material suitable for lumber still finds its way to the distillation plants. Such southern hardwoods as the oaks, red gum, tupelo, and hickory have not been important in distillation, and no information has existed in regard to the amount of the various products which could be obtained from them. Nor has information been available on the relative value of the commonly used species, or of the different forms of material, such as body wood, limbs, and slabs. The investigation here described was undertaken in order to supply this information and to aid in this way the utilization of materials now wasted.

METHOD OF INVESTIGATION.

GENERAL PLAN.

Since conditions of distillation influence the yield of products, results obtained in the laboratory could not be compared directly with those obtained in commercial operations. In order to have a direct comparison between the species commonly used and the ones which are not, it was therefore necessary to include both classes in the investigation.

The various materials were distilled under similar conditions, and their products analyzed by the same methods. In order to avoid errors due to differences in yields from different trees of the same species, in most cases an average sample of material from two or

NOTE.—Gives results of experiments in destructive distillation of hardwoods. Of interest to manufacturers of by-products.

¹ The investigation the results of which are given in this bulletin were conducted at the Forest Products Laboratory, Madison, Wis., maintained in cooperation with the University of Wisconsin.

three trees was distilled. Further, the average yields from the heartwood¹ of several trees were in a few instances compared with the yields from lumber of the same species. Differences in yields may also occur in trees of the same species grown in different localities, and for this reason the results obtained are averaged separately when more than one locality is represented. At least two distillations were made of each kind or form of material tested.

Different forms of wood—such as body wood (wood free from bark), slabs, limbs, etc.—were distilled, but the proportion of each used in commercial practice varies with different plants and localities, so that it is not possible to assume a proportion representing average conditions. For this reason the yields from different forms of wood of the same species are presented separately. The corresponding yield per given weight of wood, made up of any proportion of the various forms, can readily be calculated. However, as a basis of comparison between the species, the average yields from all heartwood runs (including lumber) are taken arbitrarily as the species value. The mean of the heartwood and slab-wood yields is also given wherever both forms were distilled.

THE RETORT.

Figure 1 shows the construction of the retort in which the distillations were made. The retort proper *A* was surrounded by the oil jacket *B*, which was filled with a high-flash-test cylinder oil. The outlet pipe *C* connected the retort with an ordinary worm condenser (not shown). The pyrometer tubes, 1, 2, 3, 4, and 5, made it possible to measure the temperature at various places within the retort. The retort was mounted on an iron stand, was insulated on all sides, and heated by a row of gas burners underneath. The flames from the burners played chiefly up one side of the cylinder and induced a fairly good circulation of the hot oil around the retort.

PREPARATION OF MATERIAL.

The forms of material used varied to some extent with different species, but most of them consisted of round bolts. These were sawed into slabs and heartwood in about the same proportion as would occur in ordinary sawmill practice, and the percentage of bark on the slabs was roughly determined. Sticks were prepared from 6 to 8 square inches in cross section and a trifle less than 18 inches long. Just before each charge of wood was weighed, six 1-inch sections, each cut from a different stick and in each case from a different part of the stick, were taken for moisture determinations.

In the comparative distillations on bark and sapwood the material was taken from the same bolts. When limbs were used they were

¹ The term "heartwood" as used in this paper applies to the material left after the slabs have been removed from a bolt or log. It was in all cases entirely free from bark, but small amounts of sapwood sometimes remained. Lumber is considered as made from heartwood as thus defined.

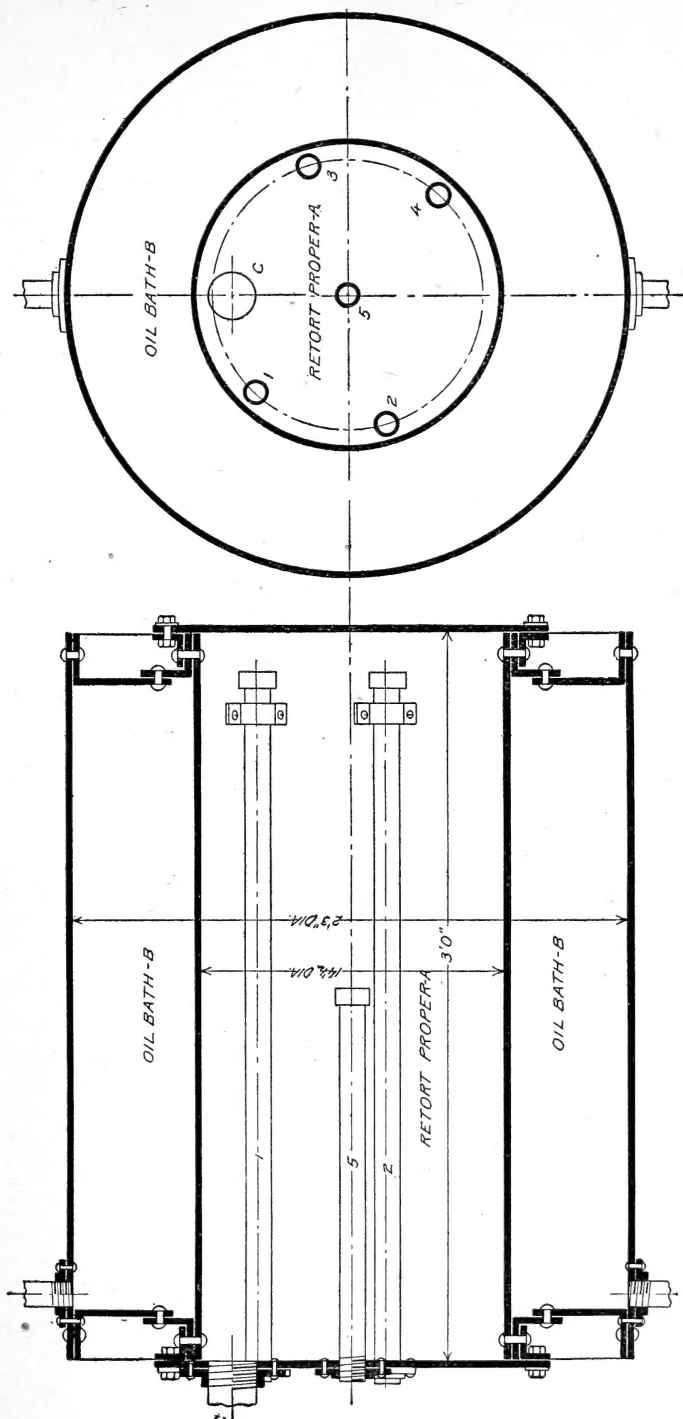

FIG. 1.—Experimental retort.

taken from the same trees as the body wood. In the case of factory waste or lumber there was, of course, no record of the trees from which the material came.

TEMPERATURES OF DISTILLATION.

It was found that the temperatures in pyrometer tubes 1, 2, 3, and 4, which are all near the surface of the retort, were always within 15° to 20° of each other, and usually within 10° during the last part of the distillation. Tube 1 was the hottest and tube 5 the coolest. It was, therefore, considered unnecessary to take temperature readings in tubes 2, 3, and 4, and the records contain the readings from tubes 1 and 5 only.

The maximum temperatures obtained in the various distillations ranged from 327° C. to 415° C., and the maximum temperatures near the surface and at the center of the retort often differed as much as 60° C. in the same distillation. These differences, however, did not appreciably affect the yields of alcohol and acetic acid, since in some instances higher temperatures gave higher yields, and in others lower. It is also found that the charcoal from low-temperature distillations, when redistilled in small samples at temperatures above 400° C., produced only small amounts of acetic acid (equivalent to an increase of 2 per cent of the original yield of acid). It was considered, therefore, that the distillations were practically complete, as to alcohol and acetic acid, provided all parts of the charge had been subjected to a temperature of at least 320° C.¹

In most of the distillations, on account of the exothermic character of the reaction, the temperature at the center of the retort finally became higher than that at the surface. It was the heat developed during the exothermic reaction which made it difficult to obtain the same maximum temperatures in all distillations; after the reaction was well started at the surface its progress toward the center was spontaneous and the maximum temperature could not be fully controlled.

The maximum temperature was usually kept below 260° C. until the water was nearly all expelled from the wood and the temperature at the center had risen to about 190° C., when it was allowed to rise more rapidly. Only in this way could the temperatures at different points in the retort be kept near one another. By this means also the possible effect of variation in moisture content was minimized, since the slow preliminary heating resulted in a partial drying of the wood, and the different charges had therefore nearly the same moisture content at the time the destructive distillation began.

¹ See Klason, von Heidenstam and Norlin, *Arkiv for Kemi Min. och Geol.* 1908, III, 9.

TABLE 1.—*Sample data sheet.*

Shipment No. 197.
 Sample Nos. 21 and 22.
 January 14, 1913.
 Actual weight of charge 69.86 pounds.
 Dry weight of charge 63.10 pounds.

Project No. 152.
 Run No. 97.
 Birch slab wood.
 10 per cent to 14 per cent bark.

Time.	Temperature.		Total distillate.	Remarks.
	Tube No. 1.	Tube No. 5.		
	° C.	° C.	c. c.	
<i>January 13.</i>				
4.30 p. m.		20		Retort charged; gas on one-half.
<i>January 14.</i>				
8.20 a. m.	234	180	3, 200	Gas on full.
10 a. m.	280	220	4, 200	
10.50 a. m.	303	246	5, 700	
11.06 a. m.	312	263	6, 700	
11.16 a. m.	317	278	7, 700	
11.22 a. m.	322	291	8, 700	
11.27 a. m.	329	305	9, 700	
11 33 a. m.	336	318	10, 700	Gas off.
11.40 a. m.	342	325	11, 700	
11.51 a. m.	342	351	12, 700	
12 a. m.	344	370	13, 200	
12.06 a. m.	341	378	13, 500	
12.11 a. m.	339	379		Maximum temperature.
12.15 a. m.	337	376		
1.50 a. m.	282	284	14, 000	
<i>January 15.</i>				
8 a. m.		50	14, 200	

Total distillate=32.83 pounds.

COLLECTION AND ANALYSIS OF PRODUCTS.

A typical data sheet is shown in Table 1. The time and temperatures were read as every liter or half liter of distillate was collected. In a few distillations separate titrations for acetic acid were made on the first several fractions of one-half liter or one liter each, but in general all the distillate was mixed for analysis.¹ The distillate was allowed to settle for at least 24 hours. At the end of that time the tar and pyroligneous acid were separated by decantation, and the volume and weight of each determined. The charcoal was allowed to cool in the retort over night, and was weighed after separation from the "tar coke." Tar coke refers to the material occurring in the retort that was clearly a residue from the distillation of tar. This was weighed separately. The gas was computed by difference, and no determination of its composition was made.

PYROLIGNEOUS ACID.

The pyroligneous acid was analyzed by the methods described by Klar² for the determination of acetic acid, wood alcohol, and dis-

¹ The acetic acid in that part of the distillate (consisting usually of water) which came over before true destructive distillation began amounted to from 8 to 10 per cent of the total acetic acid; the alcohol in the same part amounted to about 1 per cent of the total alcohol. The volatile acids obtained at temperatures below the point at which the wood begins to distill destructively, say 280° C., must have an origin different from that of the acid obtained during the destructive distillation. It is probably formed by action of the water on the wood fiber at high temperatures similarly to the acid obtained by hydrolysis as reported by Cross (Dissertation, Göttingen, 1910).

² Technologie der Holzverkohlung, p. 337.

solved tar. For the acetic-acid and dissolved-tar determinations 100 c. c. of pyroligneous acid were distilled at a maximum temperature of 140° C. until practically no further distillate appeared, when 50 c. c. of water were added and distilled off as before. The residue in the flask was weighed and computed as dissolved tar, while for the acetic-acid determination an aliquot part of the distillate was titrated with normal sodium hydroxide solution, with phenolphthalein as indicator.

The wood alcohol was determined by distilling 60 per cent from a 1-liter sample of the pyroligneous acid and adding an excess of sodium hydroxide to the distillate, again distilling 60 per cent, and after again adding sodium hydroxide, making a third distillation of 60 per cent. The final distillate was accurately weighed, and the specific gravity determined by means of a Westphal balance at room temperature and corrected to 15° C. by using the tables of Dittmar and Fawsitt.¹ In correcting the specific gravity for temperature it is necessary to consider both the concentration of alcohol and the range of temperature.

TAR.

The amount of acetic acid in the settled tar was determined, after Klar, by distilling 100 grams of the tar at 130° to 140° until the watery distillate ceased, then passing steam through the residue until no more acid was found in the distillate, the latter being then titrated, as in the pyroligneous-acid analysis, and added to that found in the pyroligneous acid.

COMPUTATION OF RESULTS.

All the yields of products were first computed to a percentage of the dry weight of the material distilled, since only on this basis are the results directly comparable, the effect of varying percentages of moisture in air-dry wood and of differences due to weight per unit volume being eliminated. But because the unit of measurement for wood is the cord, and the capacity of a plant is naturally expressed in this unit, a comparison between the various species is made also on the cord basis. A cord was assumed to contain 90 cubic feet of actual wood, and its weight was derived from the average weight per cubic foot of air-dry wood of different species as given by Snow.²

The actual volume of a cord differs, of course, for different forms of material, due to variation in diameter and shape among the individual pieces. Also, differences in density exist between wood from different parts of the tree and between wood and bark; hence between forms of material containing different proportions of wood and bark. For these reasons it was impossible to estimate closely the weight per cord of the several forms as compared with each other, and the

¹ Trans. Roy. Soc. Edin., vol. 33. Quoted in Smithsonian Physical Tables.

² The Principal Species of Wood, by C. H. Snow.

weight is therefore assumed to be the same for all forms, and the yields per cord computed on this basis.

For comparison with commercial conditions it is better also to express the yields per cord in terms of commercial products, and so they are computed as 82 per cent crude wood alcohol and 80 per cent gray acetate of lime.

YIELDS ON PERCENTAGE WEIGHT BASIS.

ALCOHOL AND ACETIC ACID.

VARIATION AMONG SPECIES.

The average yields of total acetic acid and wood alcohol, expressed in percentages of the oven-dry weight of the material distilled, are shown in Table 2.

TABLE 2.—Yields of alcohol and acetic acid in percentages of oven-dry weight of material distilled.

YIELD OF WOOD ALCOHOL (100 PER CENT).

Species.	Locality.	Heart-	Slab	Lum-	Mean	Average	Other forms.
		wood.	wood.	ber.	heart- wood and slab wood.	lumber and heart- wood.	
		<i>P. ct.</i>	<i>P. ct.</i>	<i>P. ct.</i>	<i>P. ct.</i>	<i>P. ct.</i>	<i>P. ct.</i>
Beech.....	Indiana.....	1.95	1.79	2.04	1.87	1.99	(Bark..... 1.25 Sapwood..... 1.97)
Do.....	Pennsylvania.....	2.23	2.09	2.16	
Birch.....	Wisconsin.....	1.45	1.55	1.67	1.50	1.54	
Do.....	Pennsylvania.....	1.62	1.59	1.605	
Maple.....	Wisconsin.....	1.94	1.91	1.59	1.93	1.76	Bark..... 1.88
Do.....	Pennsylvania.....	1.94	1.78	1.86	
Red gum.....	Missouri.....	1.76	1.73	1.75	
Chestnut.....	New Jersey.....	.90	.8789	Limbs..... .96
Hickory.....	Indiana.....	2.08	2.08	
White oak.....do.....	1.34	1.33	1.51	1.33	1.43	
Do.....	Arkansas.....	1.33	1.46	1.39	
Tupelo.....	Missouri.....	1.56	1.86	1.86	Limbs..... 1.64

YIELD OF ACETIC ACID (100 PER CENT).

Beech.....	Indiana.....	5.56	6.18	5.78	5.87	5.65	(Bark..... 2.98 Sapwood..... 6.67)
Do.....	Pennsylvania.....	5.77	6.21	5.99	
Birch.....	Wisconsin.....	6.71	6.88	6.62	6.80	6.68	
Do.....	Pennsylvania.....	6.19	6.10	6.15	
Maple.....	Wisconsin.....	5.42	5.11	5.58	5.24	5.49	Bark..... 3.15
Do.....	Pennsylvania.....	5.66	5.44	5.55	
Red gum.....	Missouri.....	5.70	5.23	5.46	
Chestnut.....	New Jersey.....	5.50	5.26	5.38	Limbs..... 6.42
Hickory.....	Indiana.....	5.05	5.05	
White oak.....do.....	4.97	4.77	4.84	4.87	4.78	
Do.....	Arkansas.....	4.23	4.35	4.29	
Tupelo.....	Missouri.....	4.49	5.19	5.19	Limbs..... 5.64

¹ Heartwood not included in average, since only one distillation was made on this material.

The yields of alcohol and acetic acid vary a great deal among the different species, more so for alcohol than for acetic acid. A given species may rank high in its yield of alcohol but low in its yield of acid. Thus chestnut, which gives the lowest yield of alcohol, is among the highest in yield of acid; and hickory, which is among the highest in alcohol yield, is among the lowest in acid yield.

The average yield from the beech, birch, and maple wood from Wisconsin and Indiana is somewhat higher for acid and considerably lower for alcohol than for the same species in Pennsylvania. This difference, when figured to commercial products—namely, 82 per cent alcohol and 80 per cent acetate of lime—amounts to about 10 per cent of the alcohol and $1\frac{1}{2}$ per cent of the acetate of lime (see Table 4). The greatest differences are in the alcohol yield from beech and in the acid yield from birch. In the case of maple, the yields of both acid and alcohol are slightly higher from the Pennsylvania than from the Wisconsin wood. In contrast to these variances in absolute yield, the relative yield of the three species in either product does not change with the locality. The order of yield for alcohol is beech, maple, birch; for acid, birch, beech, maple. In the case of oak, the largest difference lies in the acid yield, the material from the more southern locality giving the lower yield. The yield of alcohol from wood cut in different States is very nearly the same, but if the runs on lumber are included the average is slightly higher for material from the northern localities.

VARIATION DUE TO FORM OF MATERIAL.

Although slabs with much bark are usually considered very poor material for distillation, the yields of alcohol and acetic acid from slabs having as high as 13 to 25 per cent bark by volume are in most cases only slightly lower, and in some cases even higher, than from heartwood. Distillation of beech bark showed that the higher yields of acid from beech slabs were not due to the bark, but to the very high yields of the sapwood (slabs without bark). These offset the low bark yields sufficiently to account for the fact that slabs with 13 per cent bark yielded more acid than the heartwood without bark. The same or higher yield of acid from the slabs of birch and tupelo and from the limbs of chestnut and tupelo is probably due to the same cause. The yields of alcohol from the sapwood of beech were practically the same as from the heartwood, and since the bark yields considerably less alcohol, the slabs with 13 per cent bark yielded less than the heartwood. Maple bark yielded very nearly as much alcohol as the heartwood, which accounts for the relatively high yields from the slabs.

CHARCOAL, TAR, AND GAS.

The yields of charcoal, tar, and gas are not included in Table 2, since they are influenced very much by the maximum temperatures of distillation and therefore are not comparable to the same extent as the alcohol and acetic-acid yields. Besides, these products are of indefinite composition, which further prevents comparison. There are some points of interest, however, in the relations between the yields of these products, and in Table 3 the average yields of alcohol, tar, and charcoal are shown, the species being arranged in order of the

yields of alcohol.¹ The total tar yields follow almost the same order as the alcohol yields. The yields of charcoal, on the other hand, tend to follow the reverse order, but with more exceptions. The lowest yield of charcoal and the highest yields of alcohol and of tar are obtained from one species—hickory; while the highest yield of charcoal and the lowest yields of alcohol and of tar are also obtained from one species—chestnut.

TABLE 3.—Average yields of alcohol, total tar, and charcoal from the heartwood of various species, in percentages of dry weight of material distilled.

Species.	Alcohol.	Total tar.	Charcoal.	Species.	Alcohol.	Total tar.	Charcoal.
	<i>Per cent.</i>	<i>Per cent.</i>	<i>Per cent.</i>		<i>Per cent.</i>	<i>Per cent.</i>	<i>Per cent.</i>
Hickory.....	2.08	13.0	37.7	Tupelo.....	1.56	10.6	44.1
Beech.....	2.08	9.4	41.9	Birch.....	1.53	12.0	40.6
Maple.....	1.94	12.8	40.6	Oak.....	1.34	7.8	45.7
Red gum.....	1.76	11.7	38.6	Chestnut.....	.90	4.6	47.6

YIELDS PER CORD.

ALCOHOL AND ACETATE.

COMPARISON OF YIELDS.

Table 4 shows the same results as Table 2, but expressed in different units—the raw material in terms of gallons of 82 per cent wood alcohol and pounds of 80 per cent acetate of lime.

The yields from the various species on a cord basis are quite different from the yields on a unit weight basis; the heavier woods, such as hickory and oak, are advanced in relative position, and the lighter woods, such as chestnut and red gum, are reduced.

The average yield of alcohol from Indiana beech and Wisconsin birch and maple is 10.9 gallons per cord; the yield from these species from Pennsylvania is 11.51 gallons per cord. These figures represent the average yields obtained at commercial plants in these localities.² The average yield of acetate of lime from these two groups of woods, 319 pounds and 315 pounds per cord, respectively, is about 50 per cent higher than the average commercial yields. The yield from white oak from Arkansas of 9.2 gallons alcohol is very close to that being obtained in one commercial plant, and the acetate yield of 262 pounds per cord is, as in the case of the standard species, about 50 per cent higher than the commercial yield. The only ways in which the experimental distillations differed from commercial conditions were the low maximum temperatures and the short distance from the center of the charge to the heated surface of the retort. It is possible that these two conditions, resulting in a slow and well-controlled distillation, are sufficient to account for the higher yields.

¹ These averages do not include the yields from "lumber," since this material was usually very dry resulting in maximum temperatures much higher than the normal, giving yields of tar and charcoal not comparable with the rest of the runs.

² A corresponding difference between the Lake States and the Eastern States is also obtained commercially in the acetate yields, but this difference is not shown in the laboratory yields. It must be remembered, however, that these figures represent the average from equal proportions of the three standard species, while in actual practice one species may predominate.

In Table 5 are given the relative yields from the different forms and species, taking the average of the heartwood and lumber runs

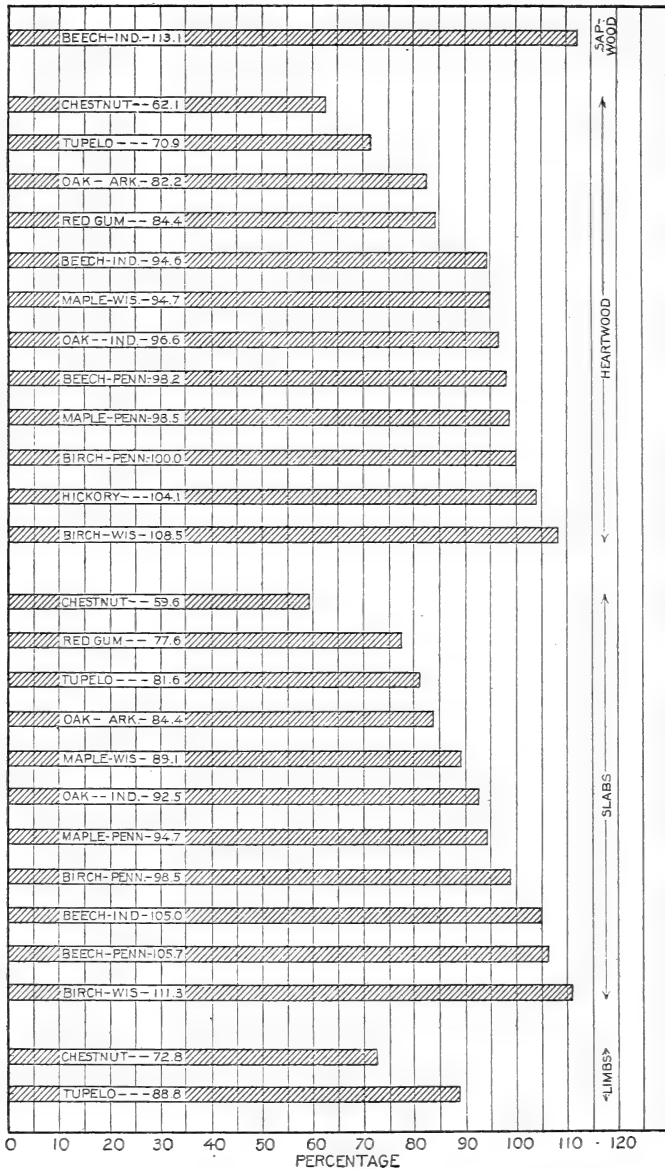

FIG. 2.—Relative yields of acetate of lime per cord. (Average yield from heartwood and lumber of beech, birch, and maple from Wisconsin=100 per cent.)

on beech, birch, and maple from Wisconsin as the standard (100 per cent). The same values are shown graphically in figures 2 and 3 for acetate and alcohol, respectively.



FIG. 3.—Relative yields of wood alcohol per cord of wood. (Average yield from heartwood and lumber of beech, birch, and maple from Wisconsin=100 per cent.)

TABLE 4.—*Yields of commercial alcohol and acetate from various species per cord of wood.*

YIELD OF WOOD ALCOHOL (82 PER CENT).

Species.	Locality.	Heart-wood.	Slab wood.	Lumber.	Mean heart-wood and slab wood.	Average lumber and heart-wood.	Other forms.
Beech.....	Indiana.....	<i>Gals.</i> 11.8	<i>Gals.</i> 10.9	<i>Gals.</i> 12.2	<i>Gals.</i> 11.4	<i>Gals.</i> 12.05	Sapwood... <i>Gals.</i> 11.9
Do.....	Pennsylvania.....	13.5	12.6	13.15
Birch.....	Wisconsin.....	8.3	8.9	9.6	8.6	8.9
Do.....	Pennsylvania.....	9.3	9.1	9.2
Maple.....	Wisconsin.....	11.8	11.6	9.87	11.7	10.9
Do.....	Pennsylvania.....	11.85	10.7	11.3
Red gum.....	Missouri.....	9.4	9.2	9.3
Chestnut.....	New Jersey.....	3.7	3.6	3.6	Limbs..... 3.9
Hickory.....	Indiana.....	15.3
White oak.....	do.....	9.2	9.2	10.4	9.2	9.9
Do.....	Arkansas.....	9.2	10.1	9.65
Tupelo.....	Missouri.....	8.75	10.4	9.1	Limbs..... 9.2

¹ Single unchecked determination.

YIELD OF ACETATE OF LIME (80 PER CENT).

Species.	Locality.	Heart-wood.	Slab wood.	Lumber.	Mean heart-wood and slab wood.	Average lumber and heart-wood.	Other forms.	Weight per cord ¹ (15 per cent moisture).
Beech.....	Indiana.....	<i>Lbs.</i> 301	<i>Lbs.</i> 335	<i>Lbs.</i> 313	<i>Lbs.</i> 318	<i>Lbs.</i> 307	Sapwood... <i>Lbs.</i> 361	<i>Lbs.</i> 3,785
Do.....	Pennsylvania.....	313	337	325	3,785
Birch.....	Wisconsin.....	346	355	341	350	343	3,600
Do.....	Pennsylvania.....	319	314	316	3,600
Maple.....	Wisconsin.....	301	284	310	293	305	3,875
Do.....	Pennsylvania.....	314	302	308	3,875
Red gum.....	Missouri.....	269	247	255	3,300
Chestnut.....	New Jersey.....	198	190	194	Limbs..... 232	2,520
Hickory.....	Indiana.....	332	332	4,590
White oak.....	do.....	308	295	300	301	305	4,320
Do.....	Arkansas.....	262	269	265	4,320
Tupelo.....	Missouri.....	226	260	243	Limbs..... 283	3,510

¹ The weights per cord are derived as explained on p. 6.TABLE 5.—*Relative yields of commercial alcohol and acetate per cord of wood of various species.*¹[Average yields² from heartwood and lumber of beech, birch, and maple from Wisconsin equals 100 per cent.]

Species.	Locality.	Yield of acetate of lime (80 per cent).			Yield of wood alcohol (82 per cent).			
		Heart-wood.	Slab wood.	Other forms.	Heart-wood.	Slab wood.	Other forms.	
Beech.....	Indiana.....	<i>Gals.</i> 94.6	<i>Gals.</i> 105.0	<i>Gals.</i> 113.1	<i>Gals.</i> 108.2	<i>Gals.</i> 100.0	Sapwood <i>Gals.</i> 109.1
Do.....	Pennsylvania.....	98.2	105.7	124.0	115.6
Birch.....	Wisconsin.....	108.5	111.3	75.2	81.6
Do.....	Pennsylvania.....	100.0	98.5	85.4	83.5
Maple.....	Wisconsin.....	94.7	89.1	108.2	106.5
Do.....	Pennsylvania.....	98.5	94.7	108.8	98.2
Red gum.....	Missouri.....	84.4	77.6	86.2	84.5
Chestnut.....	New Jersey.....	62.1	59.6	Limbs... 72.8	33.9	33.0	Limbs.. 35.8
Hickory.....	Indiana.....	104.1	140.5
White oak.....	do.....	96.6	92.5	84.5	84.5
Do.....	Arkansas.....	82.2	84.4	84.5	92.7
Tupelo.....	Missouri.....	70.9	81.6	Limbs... 88.8	80.3	95.5	Limbs.. 84.4

¹ The weights per cord are derived as explained on p. 6.² Acetate of lime, 80 per cent, 319 pounds; alcohol, 82 per cent, 10.9 gallons.

COMPARISON OF VALUES.

The combined value of commercial alcohol and acetate of lime from the various forms of material per cord of wood of the various species is given in Table 6, which is computed from the yields given in Table 4. These values are according to the prevailing prices for 1911-13.¹

In judging the value of the different forms and species for distillation, the yields under commercial conditions must be considered, and therefore the value of the acetate per cord of wood of different species is computed on a basis of two-thirds of the yields shown. The value of the alcohol is based on the experimental yields, since these are at most only slightly higher than average commercial yields. Tar and gas are not included in the computation of the value of products, because they are relatively unimportant and are commonly used as fuel at the plant. Charcoal is one of the valuable commercial products, but is not included because there are no definite data from which the values might be computed. The charcoal produced by the experimental method has not been subjected to temperatures as high as in commercial practice, and therefore contains more volatile matter. Although the relation between the yields obtained from different species in the experiments might be the same as between those obtained by commercial methods, there is no information on the quality of the charcoal from different species. Also, charcoal is usually sold by volume, and since no data are available on the weight per bushel for that produced from different species, the yields can not be computed to commercial units.

TABLE 6.—Values of commercial alcohol and acetate per cord of wood of various species.¹

Species.	Locality.	Values of wood alcohol and acetate of lime during period 1911-13. ²						Weight of cord, ³ (15 per cent moisture).
		Heart-wood.	Slab-wood.	Lumber.	Mean heart-wood and slab wood.	Other forms.	Average lumber and heart-wood.	
Beech.....	Indiana.....	\$8.08	\$8.41	\$8.38	\$8.25	Sapwood, \$9.10..	\$8.23	<i>Pounds.</i> 3,785
Do.....	Pennsylvania.....	8.72	8.89	8.81	3,785
Birch.....	Wisconsin.....	7.92	8.22	8.17	8.07	8.04	3,600
Do.....	Pennsylvania.....	7.73	7.59	7.66	3,600
Maple.....	Wisconsin.....	8.08	7.74	7.72	7.91	7.90	3,875
Do.....	Pennsylvania.....	8.31	7.80	8.06	3,875
Red gum.....	Missouri.....	6.92	6.50	6.71	3,300
Chestnut.....	New Jersey.....	4.28	4.11	4.19	Limbs, \$4.89.....	2,520
Hickory.....	Indiana.....	9.51	9.51	4,590
Oak.....	do.....	7.52	7.30	7.70	7.41	7.61	4,320
Do.....	Arkansas.....	6.76	7.08	6.92	4,320
Tupelo.....	Missouri.....	4 6.04	7.03	6.59	Limbs, \$7.10.....	3,510

¹ The market price of crude alcohol is fairly stable, but acetate of lime fluctuates considerably from time to time. For this reason the relative value of the different species, from the standpoint of value of products, may vary from the calculations indicated.

² The weights per cord are derived as explained on p. —.

³ At 26 cents per gallon for alcohol and \$2.50 per hundredweight for acetate of lime. The acetate is computed from two-thirds the yields given in Table 4.

⁴ One determination only.

TABLE 7.—Relative values of commercial alcohol and acetate per cord of wood of various species.¹

[Average value of yields from heartwood and lumber of beech, birch, and maple from Wisconsin (\$8.06) equals 100 per cent.]

Species.	Locality.	Heart-wood.	Slabs.	Heart-wood and lumber.	Mean heart-wood and slabs.	Sapwood.	Limbs.
		<i>Per cent.</i>	<i>Per cent.</i>	<i>Per cent.</i>	<i>Per cent.</i>	<i>Per cent.</i>	<i>Per cent.</i>
Beech.....	Indiana.....	100.2	104.2	102.1	102.5	113.0
Do.....	Pennsylvania.....	103.1	110.2	109.2
Birch.....	Wisconsin.....	98.4	102.0	97.7	100.1
Do.....	Pennsylvania.....	96.0	95.5	95.8
Maple.....	Wisconsin.....	100.2	96.0	95.8	93.1
Do.....	Pennsylvania.....	103.0	97.0	100.0
Red gum.....	Missouri.....	86.0	80.7	83.3
Chestnut.....	New Jersey.....	53.2	51.0	52.1	60.7
Hickory.....	Indiana.....	118.0
White oak.....	do.....	93.3	90.7	94.5	92.0
Do.....	Arkansas.....	83.9	85.0	85.9
Tupelo.....	Missouri.....	75.0	87.2	81.8	88.1

¹ The weights per cord are derived as explained on p. 6.

Assuming that the value of the charcoal and the cost of plant operation per cord of wood is the same for all species, the differences in the value of the alcohol and acetate produced by the various woods represent the differences in the value of these woods for distillation purposes.¹ The average value of the alcohol and acetate yields from Indiana beech and Wisconsin birch and maple heartwood is \$8.06 per cord. The values of these products from the heartwood of chestnut, red gum, tupelo (slabs), and southern and northern oak, are less than this amount by \$3.78, \$1.14, \$1.03, \$1.30, and \$0.54, respectively; from hickory (factory waste) the products are \$1.55 greater in value. The average price paid is only about \$3.50 per cord, and consequently the use of chestnut for this purpose is out of the question. Oak, tupelo, and red gum, under favorable conditions of supply and cost, might be used profitably, while hickory should command a very good price for this purpose. Since these deductions are based on the value of the chemical products they apply less strongly in case of plants making only a partial recovery of these products.

The value of alcohol and acetate from the different forms and species as given in Table 6 are compared in Table 7 by means of a standard value. This value is \$8.06, being the average value of beech (from Indiana), birch, and maple heartwood (from Wisconsin). This standard is taken as 100 per cent and the other values are ranked accordingly.

¹ The assumption in regard to the cost of operation will undoubtedly hold so far as the destructive distillation of the wood is concerned. However, the cost of the refining operations is approximately proportionate to the amount of crude pyroligneous acid produced; although this is variable, it bears some relation to the yield of refined products. The large amount of crude pyroligneous acid per cord of hickory would tend to increase the refining cost per cord of wood; likewise the low yields of crude pyroligneous acid from chestnut, tupelo, and red gum would tend to lower the cost of these woods. Therefore, the assumption made is not entirely correct, but the differences are not great enough to affect seriously the conclusions.

The value of the two products (alcohol and acetate) from hickory is 18 per cent greater than the standard chosen for the comparison. Of the other species, oak from Indiana is the only one which falls above 90 per cent; with all the others, except chestnut, the average yield from heartwood and slab wood is above 80 per cent.

Of equal interest to these relative values based upon species are the relative values of the different forms of wood from the same species. These relations are shown in Table 8, in which the value of heartwood in each case is taken as 100 per cent. A number of species show a higher value for slabs than for heartwood. The slabs of Indiana beech, Wisconsin birch, Pennsylvania beech, and Arkansas oak are from 2 to 5 per cent higher than the heartwood, while the limbs of the two species tested, chestnut and tupelo, are about 15 per cent higher than heartwood. These results are based upon equal weights of the several forms of material compared.

TABLE 8.—Relative values of commercial alcohol and acetate from equal weights of various forms of material.

[Heartwood=100 per cent.]

Species.	Locality.	Heartwood.	Slab wood.	Sapwood.	Limbs.
		<i>Per cent.</i>	<i>Per cent.</i>	<i>Per cent.</i>	<i>Per cent.</i>
Beech.....	Indiana.....	100	104.0	112.5
Do.....	Pennsylvania.....	100	102.0
Birch.....	Wisconsin.....	100	103.8
Do.....	Pennsylvania.....	100	98.2
Maple.....	Wisconsin.....	100	95.8
Do.....	Pennsylvania.....	100	93.9
Red gum.....	Missouri.....	100	94.0
Chestnut.....	New Jersey.....	100	96.0	114.2
Hickory.....	Indiana.....	100
White oak.....	do.....	100	97.2
Do.....	Arkansas.....	100	104.8
Tupelo.....	Missouri.....	100	116.5	117.5

PYROLIGNEOUS ACID, TAR, AND CHARCOAL.

The average yields of pyroligneous acid, tar, and charcoal from the various forms of material, expressed in pounds per cord for each species, are given in Table 9. Although the yields of these products, especially of the last two, are directly affected by the maximum temperatures of distillation, and are therefore not as accurate as the alcohol and acetate yields, some conclusions of interest can be drawn from them. The yields of pyroligneous acid are of interest mainly in connection with the cost of refining the products from a cord of wood. (See footnote on p. 14.)

The average commercial yield of charcoal from a cord of beech, birch, and maple is about 50 bushels or (at 20 pounds, the usual weight per bushel) 1,000 pounds; the average yield from the heartwood of the three species by the experimental method is 1,378 pounds per cord. This large difference is probably due chiefly to the low maximum temperatures of distillation, resulting in a charcoal with a high amount of volatile matter. Charcoal of this composition would probably be satisfactory as a fuel for domestic use, but where

high carbon content or high crushing strength is required it might not be suitable.

The yields of tar are also somewhat higher than those usually obtained in practice, and this can not be explained entirely by the low maximum temperature of distillation, since further distillation of the charcoal at higher temperatures gave increased production of tar. (See p. 4.) It is probable, however, that under the experimental conditions of distillation there was less tar decomposed into gas and coke than under commercial conditions where part of the tar would be subjected to considerably higher temperatures after formation.

TABLE 9.—Average yields per cord of pyroligneous acid, charcoal, and tar from various species.¹

PYROLIGNEOUS ACID (MINUS MOISTURE).

Species.	Locality.	Heart-	Slab	Lum-	Mean	Average	Other forms.
		wood.	wood.	ber.	heart- wood and slab wood.	lumber and heart- wood.	
		<i>Lbs.</i>	<i>Lbs.</i>	<i>Lbs.</i>	<i>Lbs.</i>	<i>Lbs.</i>	<i>Lbs.</i>
Beech.....	Indiana.....	1,062	1,165	1,119	1,113	1,085	Sapwood.. 1,149
Do.....	Pennsylvania.....	1,180	1,158	1,169	
Birch.....	Wisconsin.....	1,152	1,159	1,220	1,156	1,167
Do.....	Pennsylvania.....	1,249	1,135	1,192	
Maple.....	Wisconsin.....	1,120	1,061	1,207	1,145	1,157
Do.....	Pennsylvania.....	1,125	1,164	1,145	
Red gum.....	Missouri.....	1,098	917	1,005	Limbs.... 714
Chestnut.....	New Jersey.....	790	644	716	
Hickory.....	Indiana.....	1,495	1,495
White oak.....	do.....	1,230	1,170	1,275	1,200	1,156	
Do.....	Arkansas.....	1,155	1,120	1,135	Limbs.... 1,049
Tupelo.....	Missouri.....	1,081	1,065	1,073	

CHARCOAL.

Beech.....	Indiana.....	1,417	1,297	1,385	1,357	1,403	Sapwood.. 1,470
Do.....	Pennsylvania.....	1,335	1,383	1,359	
Birch.....	Wisconsin.....	1,315	1,284	1,286	1,300	1,303
Do.....	Pennsylvania.....	1,228	1,300	1,265	
Maple.....	Wisconsin.....	1,341	1,515	1,348	1,344	1,430
Do.....	Pennsylvania.....	1,352	1,288	1,310	
Red gum.....	Missouri.....	1,058	1,360	1,210	Limbs.... 1,061
Chestnut.....	New Jersey.....	1,041	1,160	1,102	
Hickory.....	Indiana.....	1,500	1,500
White oak.....	do.....	1,858	1,832	1,625	1,875	1,715	
Do.....	Arkansas.....	1,580	1,734	1,654	Limbs.... 1,320
Tupelo.....	Missouri.....	1,400	1,405	1,402	

TOTAL TAR.

Beech.....	Indiana.....	319	349	342	332	329	Sapwood.. 250
Do.....	Pennsylvania.....	299	359	329	
Birch.....	Wisconsin.....	325	285	338	307	330
Do.....	Pennsylvania.....	426	347	385	
Maple.....	Wisconsin.....	418	310	500	450	360
Do.....	Pennsylvania.....	422	416	418	
Red gum.....	Missouri.....	336	215	276	Limbs.... 173
Chestnut.....	New Jersey.....	102	80	91	
Hickory.....	Indiana.....	519	519
White oak.....	do.....	237	173	331	203	285	
Do.....	Arkansas.....	349	327	338	Limbs.... 447
Tupelo.....	Missouri.....	348	370	364	

¹ The weights per cord were derived as explained on p. 6.

